

SHEET=2

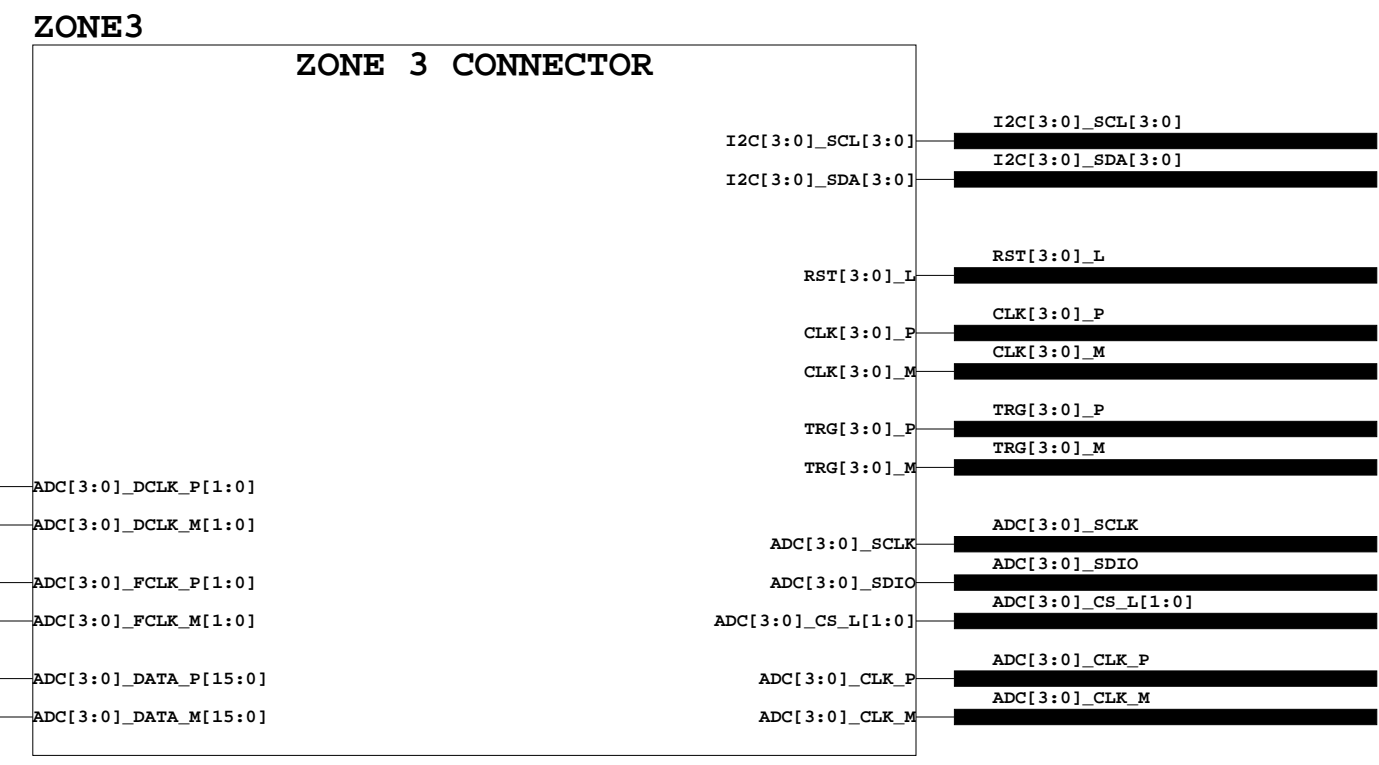

SHEET=23

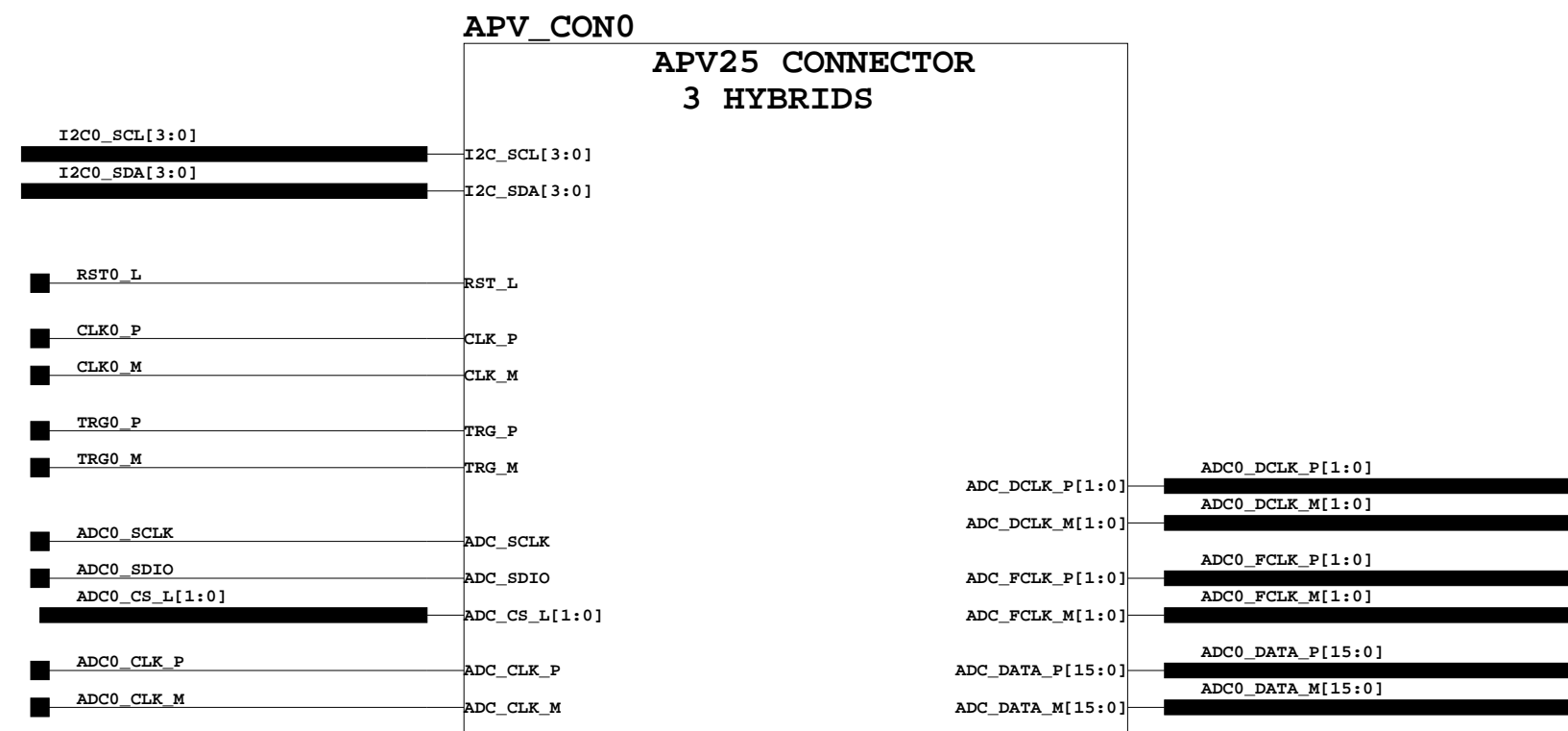

SHEET=3

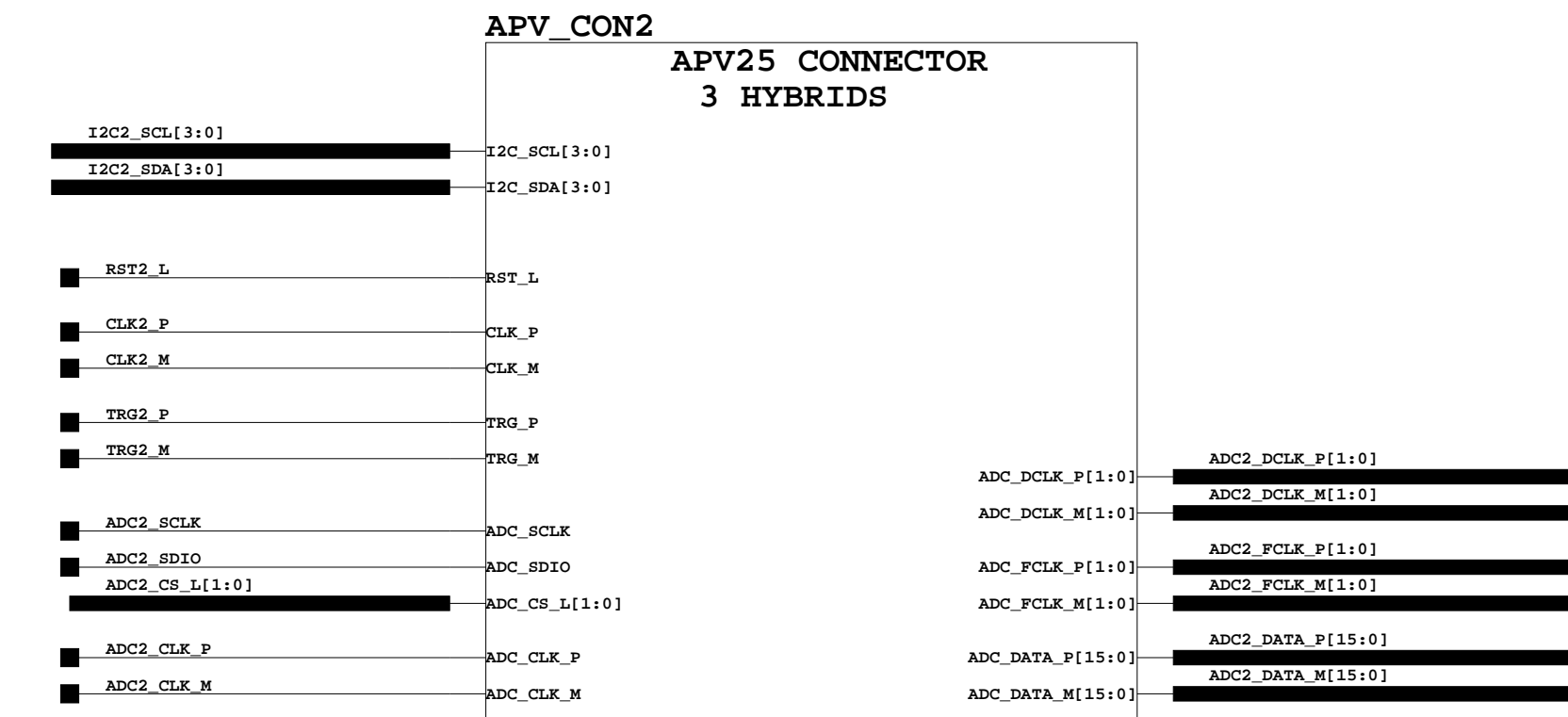

SHEET=13

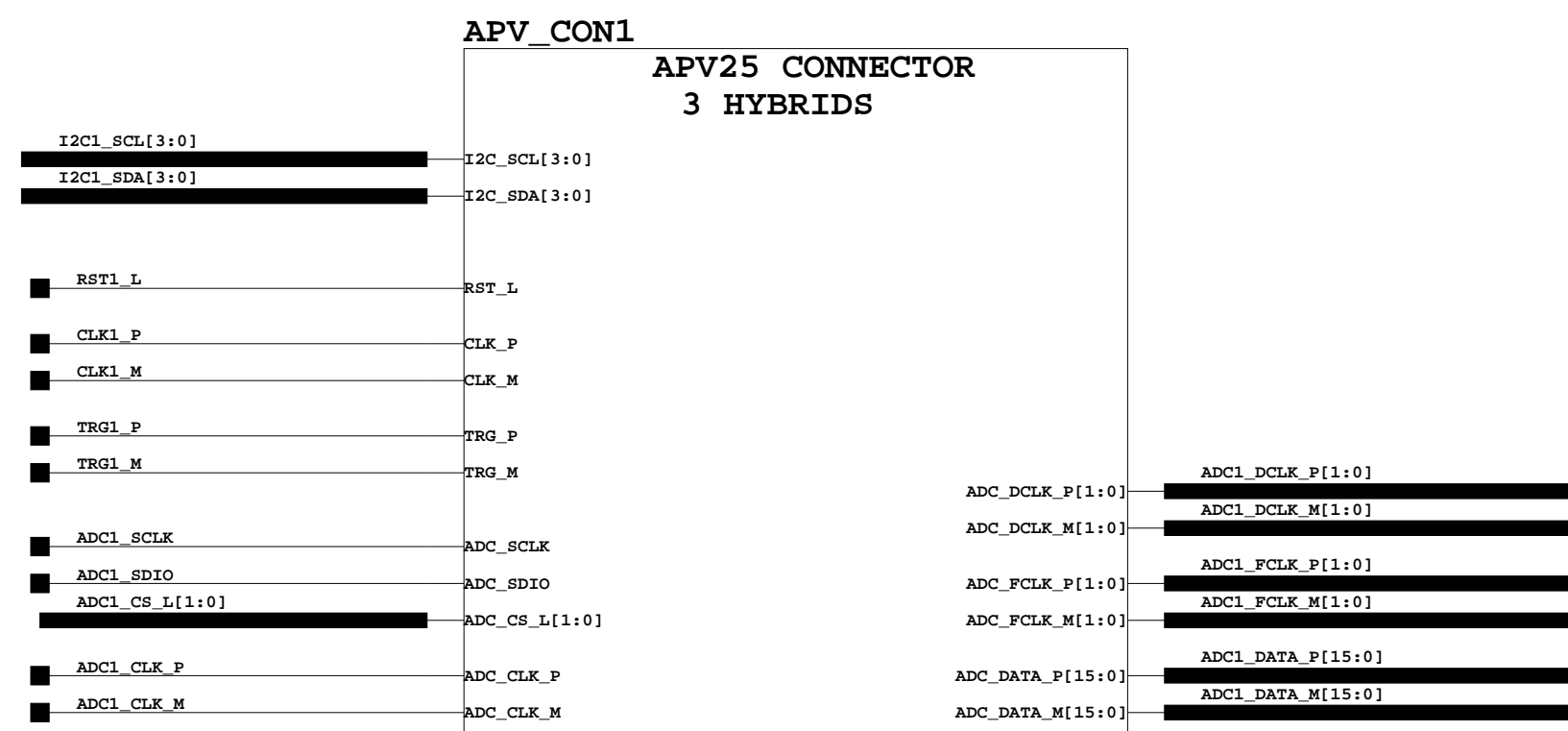

SHEET=8

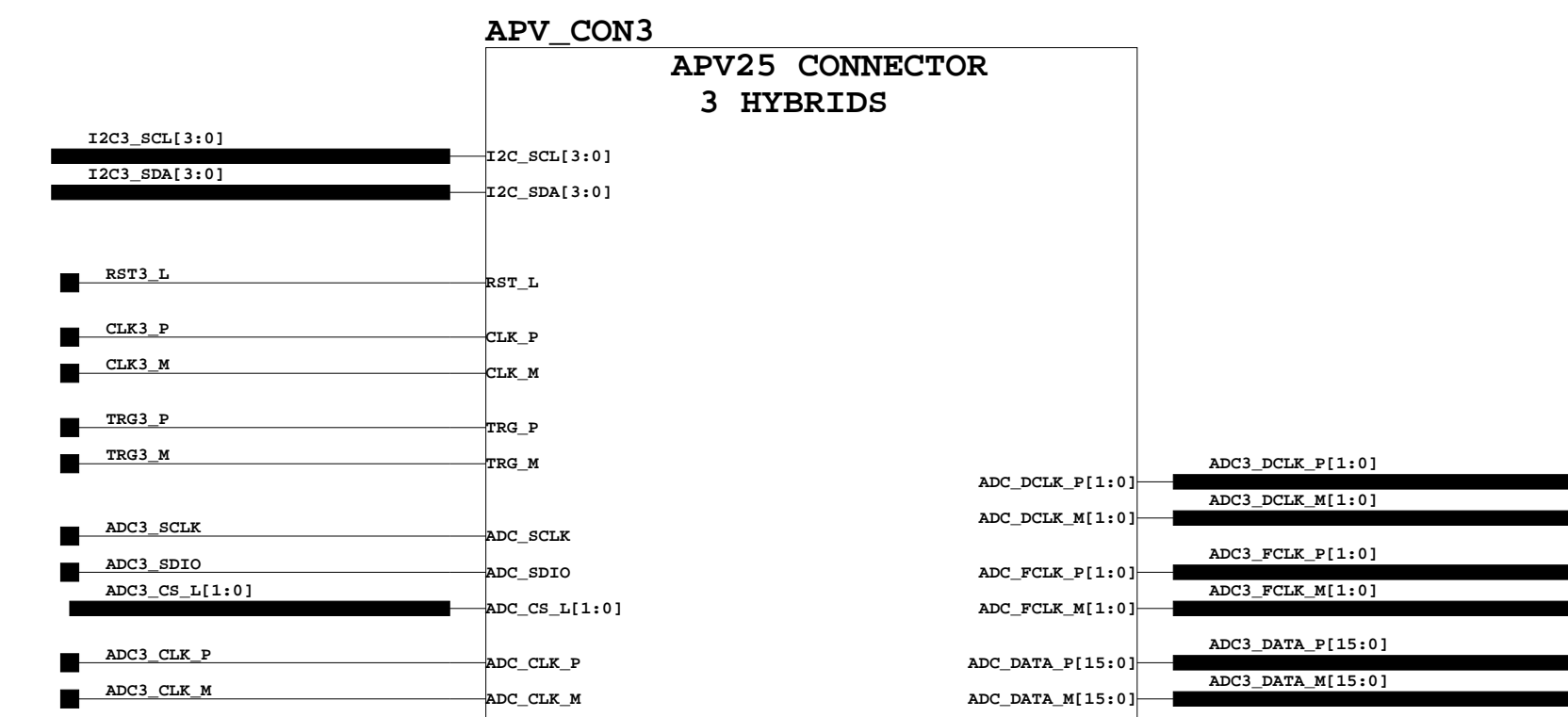

SHEET=18

1-24-2011\_15:37

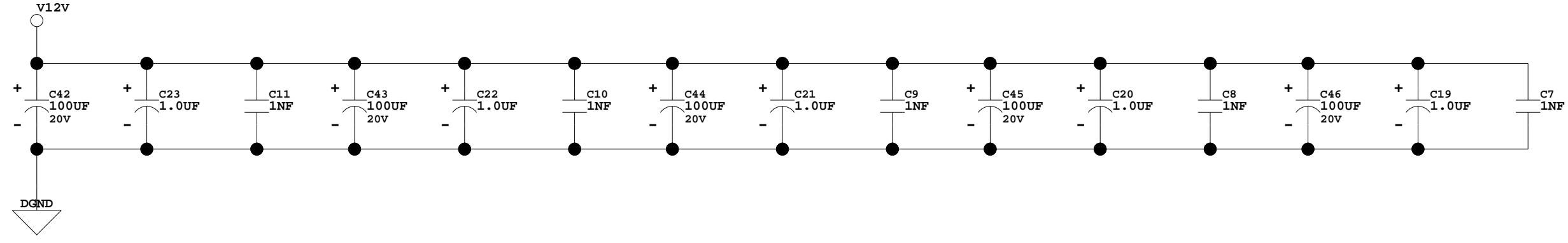
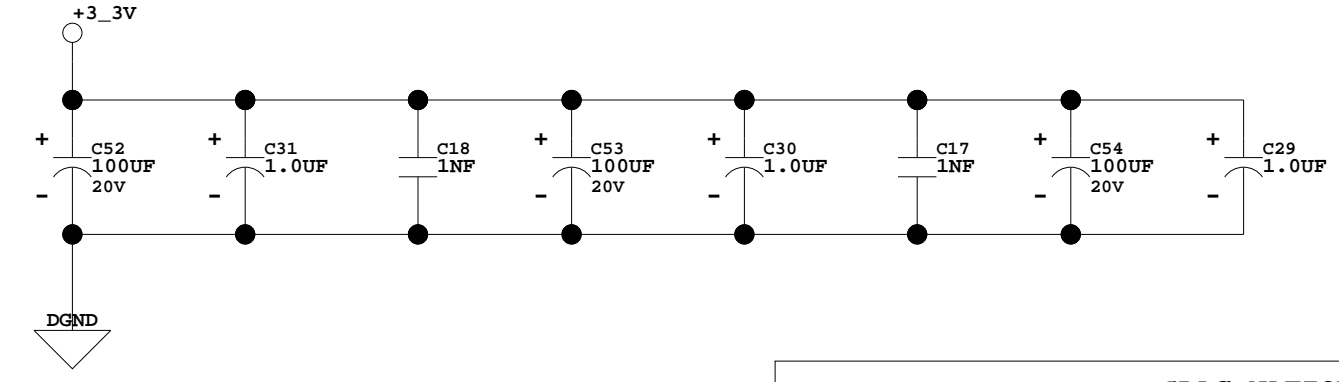
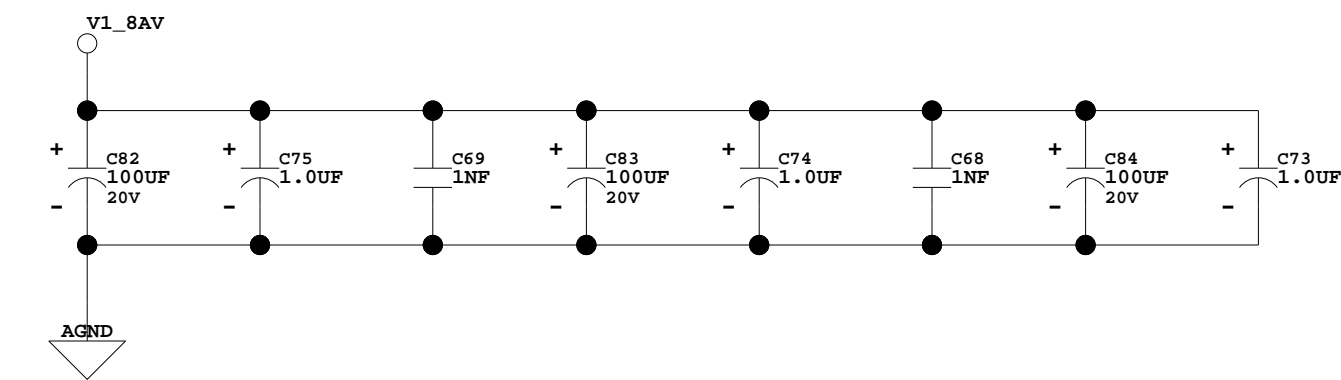
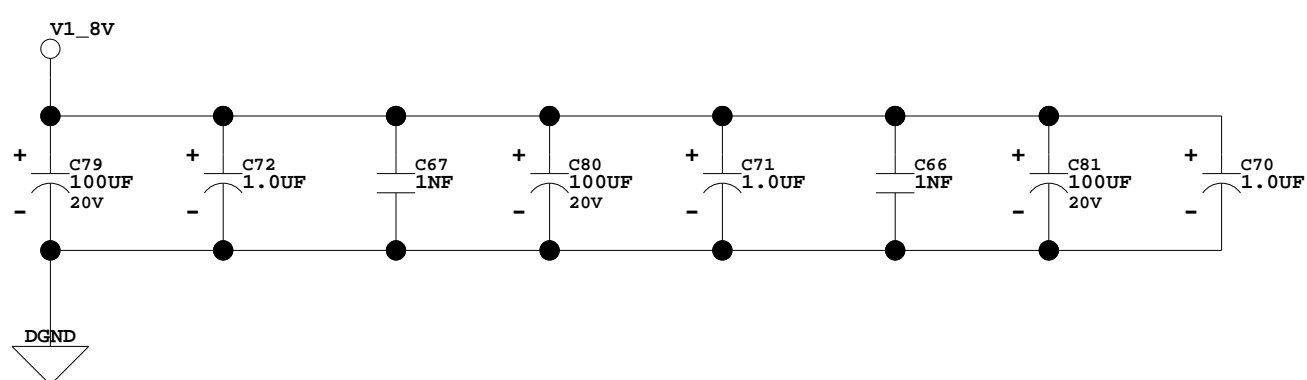
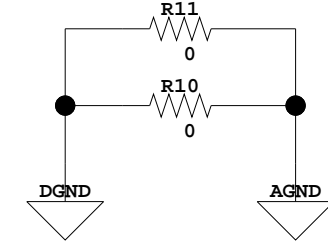
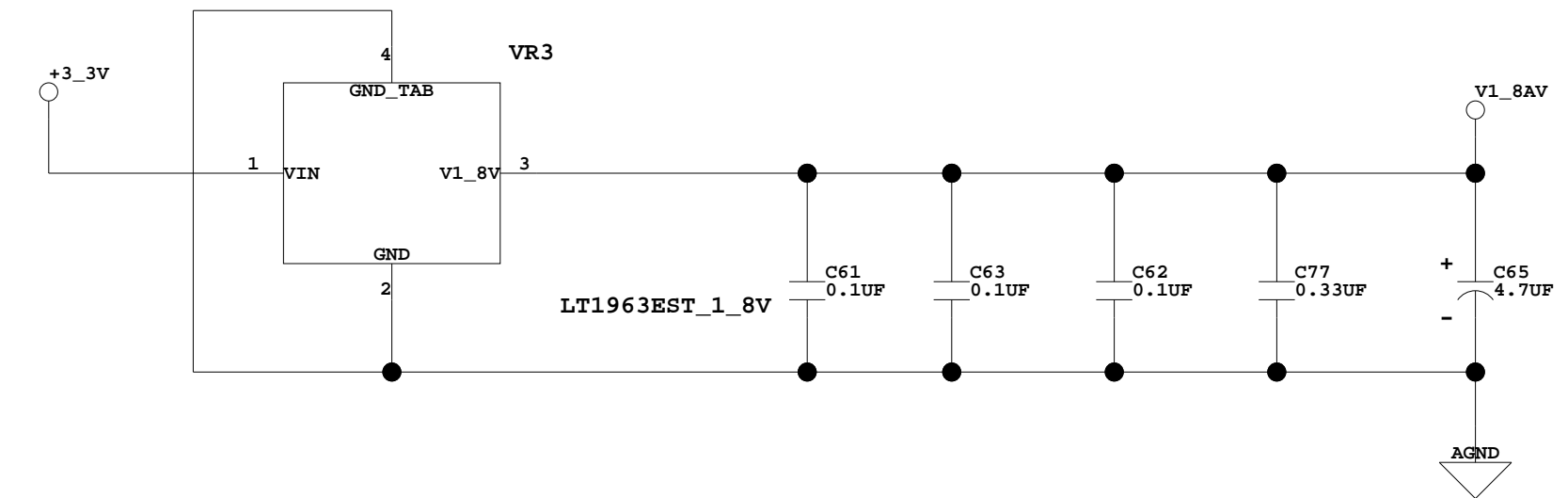
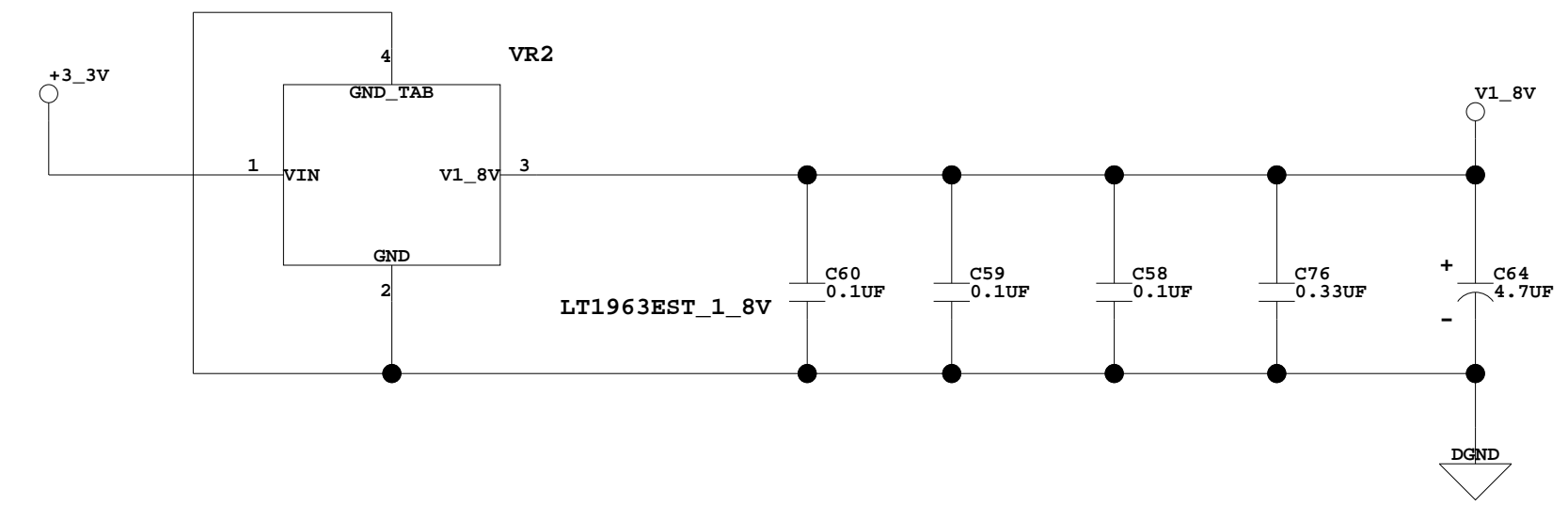
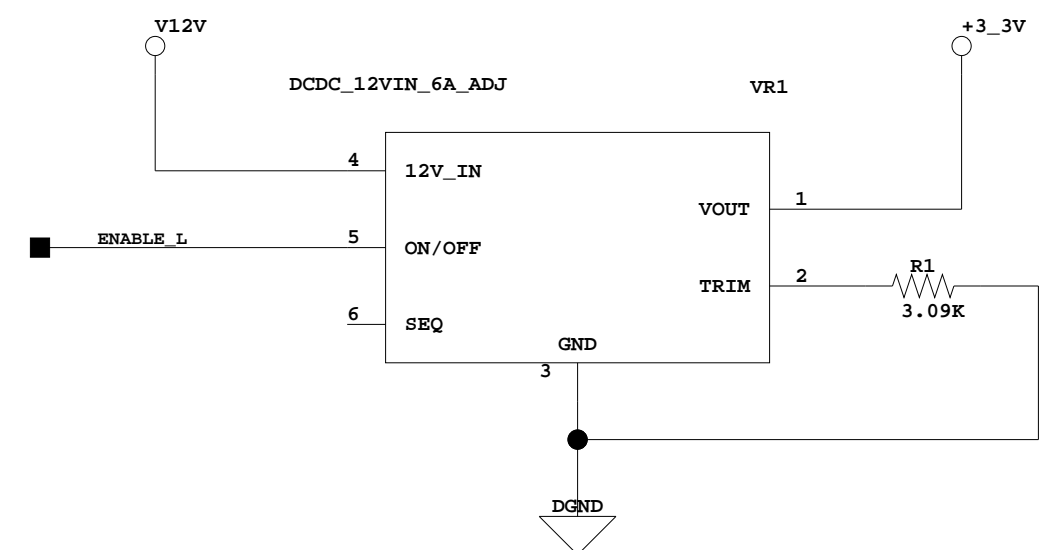
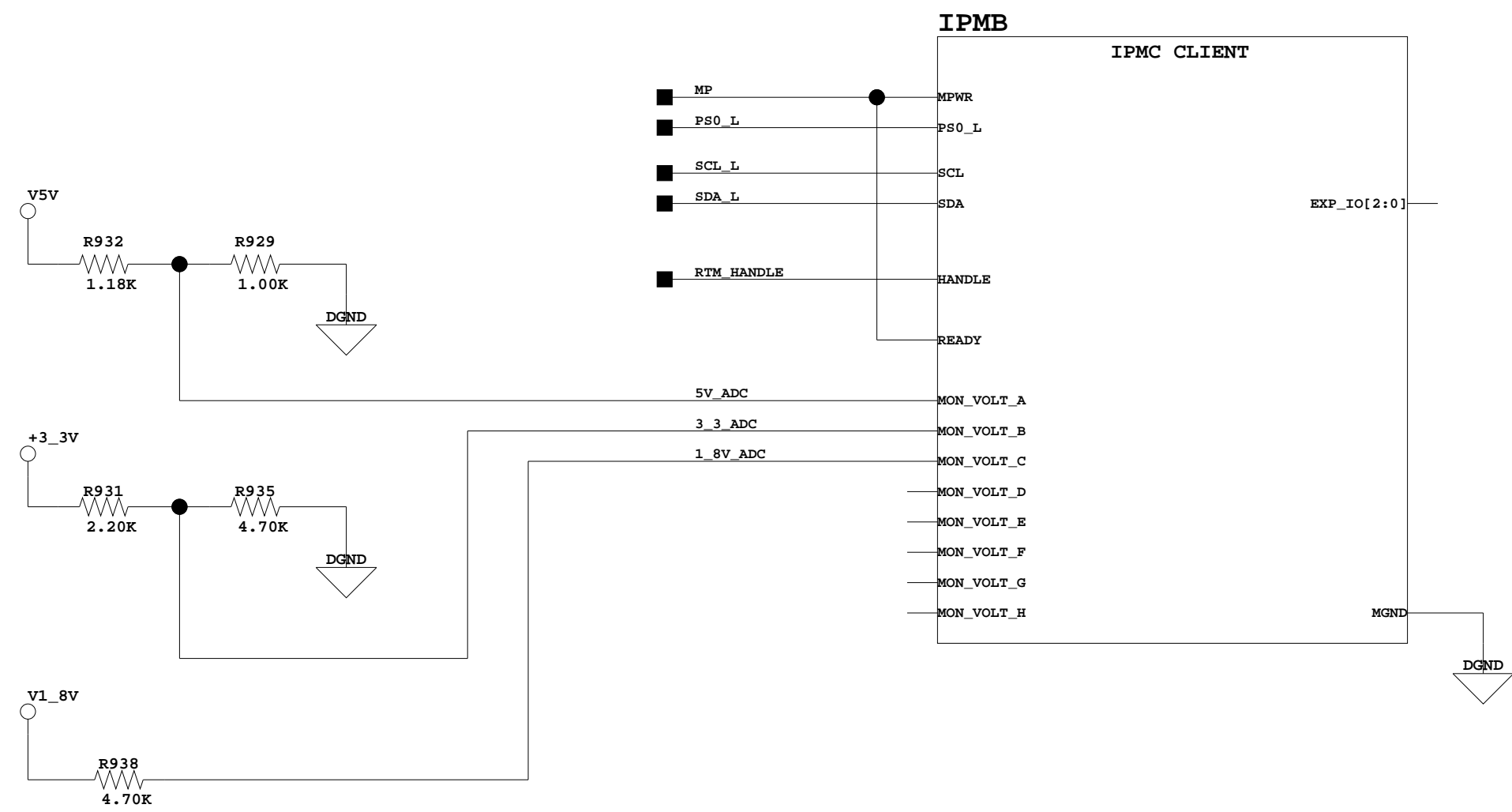
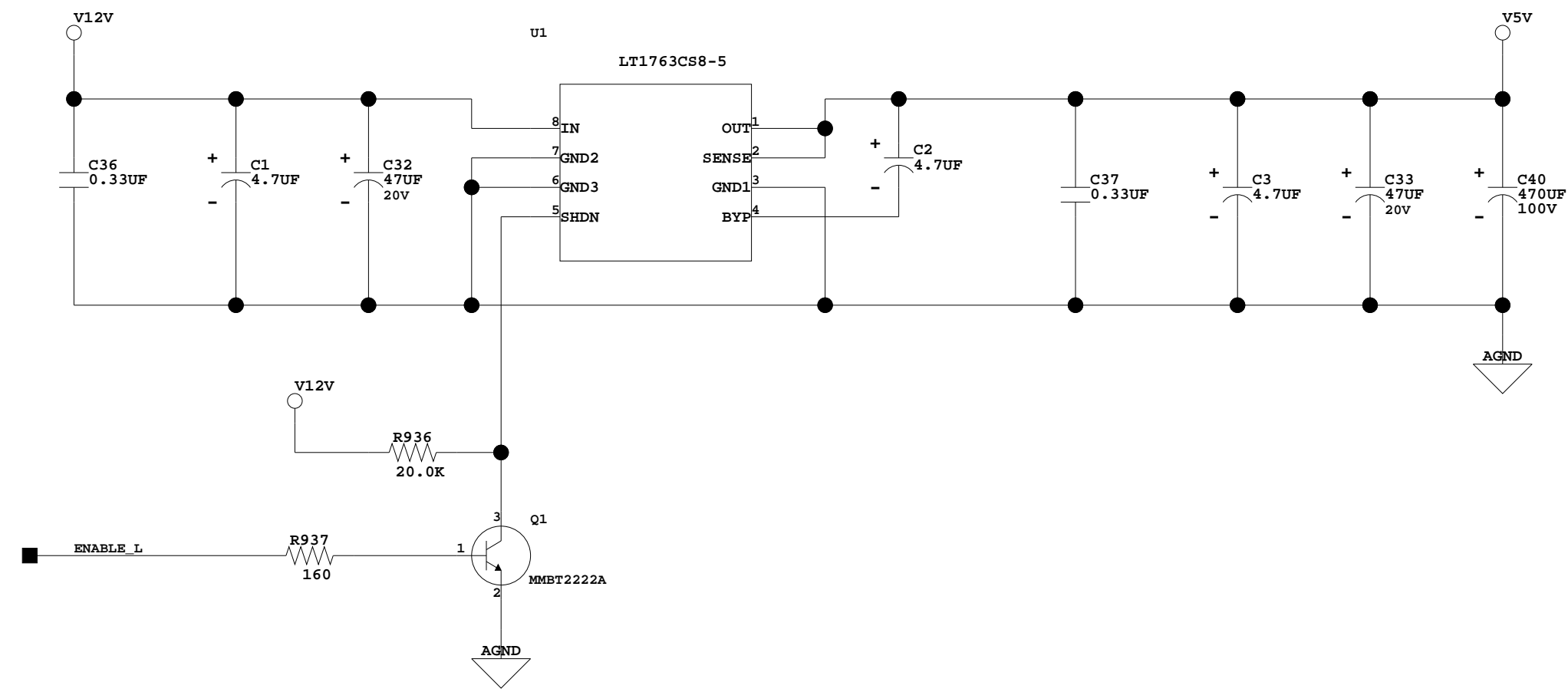
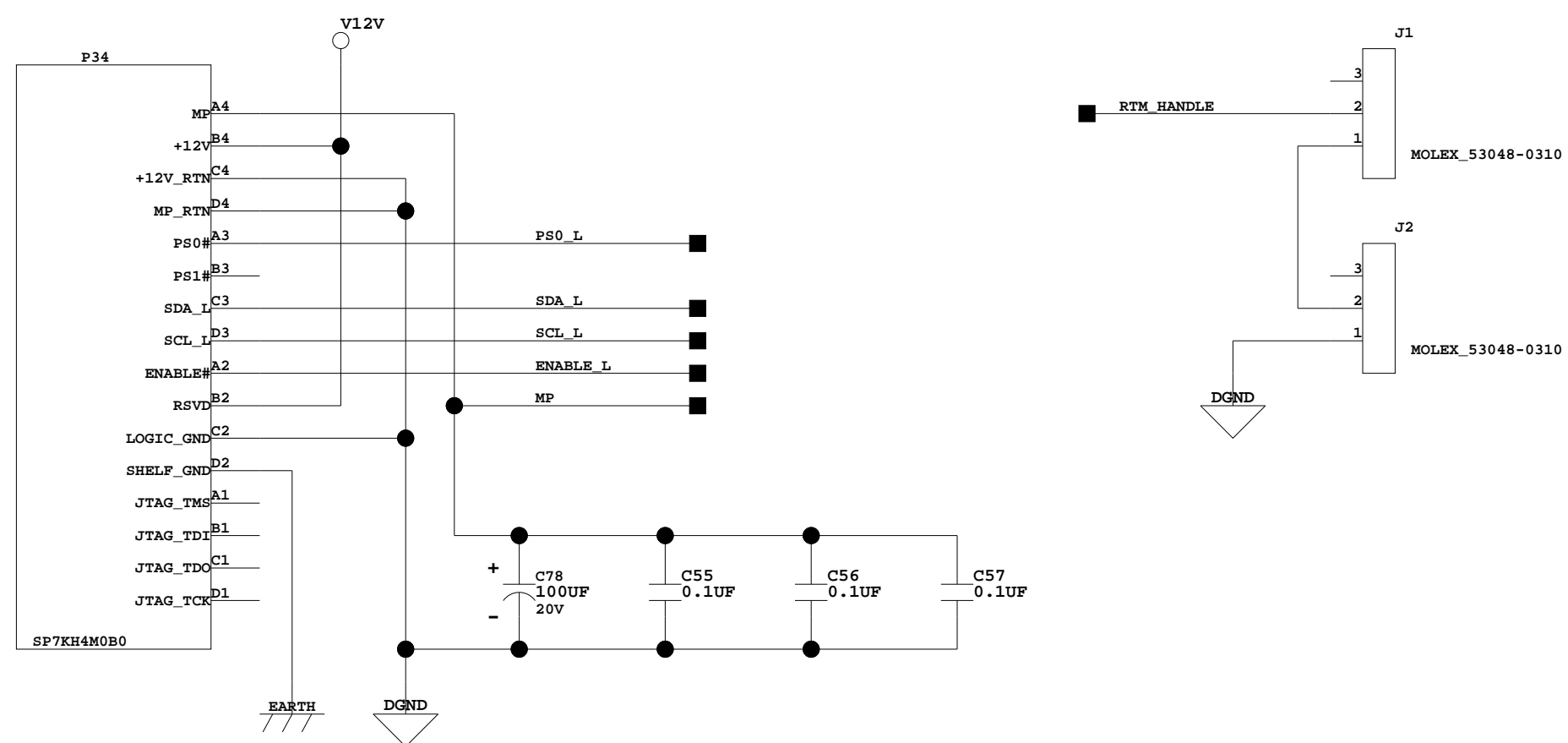

1-24-2011\_15:40

SLAC NATIONAL ACCELERATOR LABORATORY	
U.S. DEPARTMENT OF ENERGY	
STANFORD UNIVERSITY	STANFORD, CALIFORNIA
PROPRIETARY DATA OF STANFORD UNIVERSITY AND/OR U.S. DEPARTMENT OF ENERGY. RECIPIENT SHALL NOT PUBLISH THE INFORMATION WITHIN UNLESS GRANTED SPECIFIC PERMISSION OF STANFORD UNIVERSITY.	
DRWR	DATE
DFTR	APPROVALS
CDR	

SHEET 2 OF 23

HEAVY P TRACKER READOUT RTM  
POWER REGULATORS

LOCATED AT SHEET 1

SD-249-901-02-C01

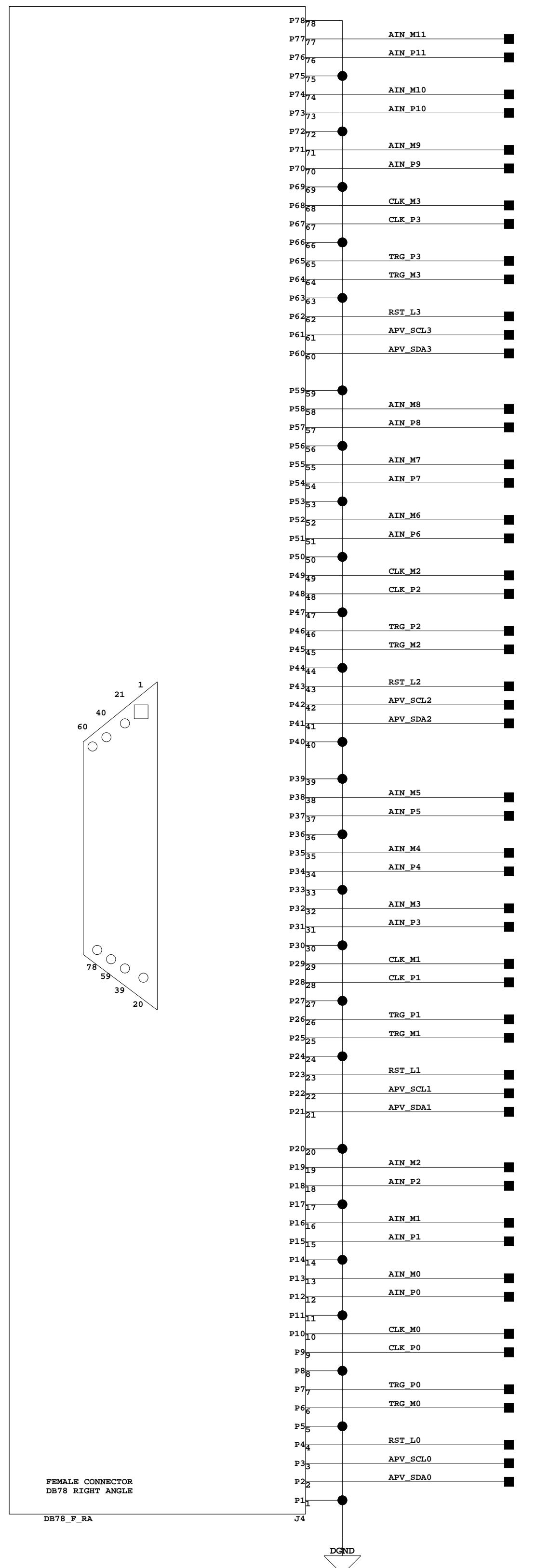

FEMALE CONNECTOR DB78 RIGHT ANGLE DB78\_F\_RA

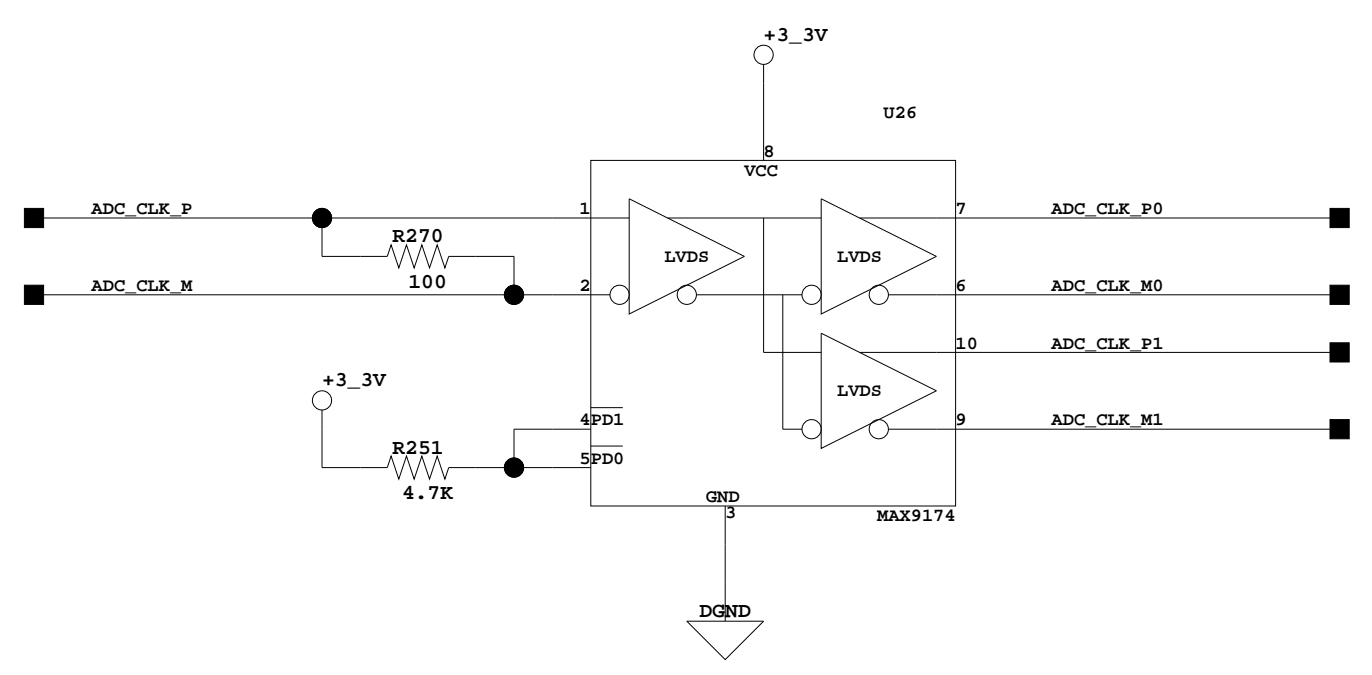
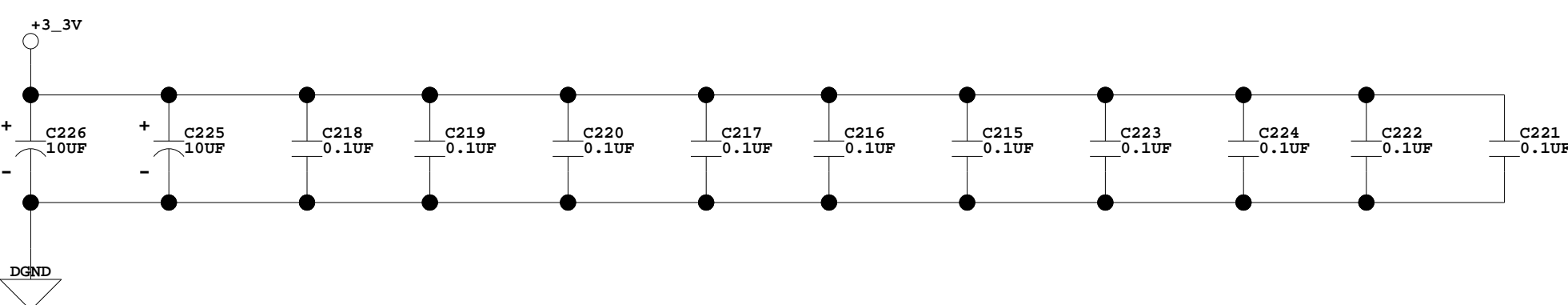

I2C\_SCL[3:0]  
I2C\_SDA[3:0]

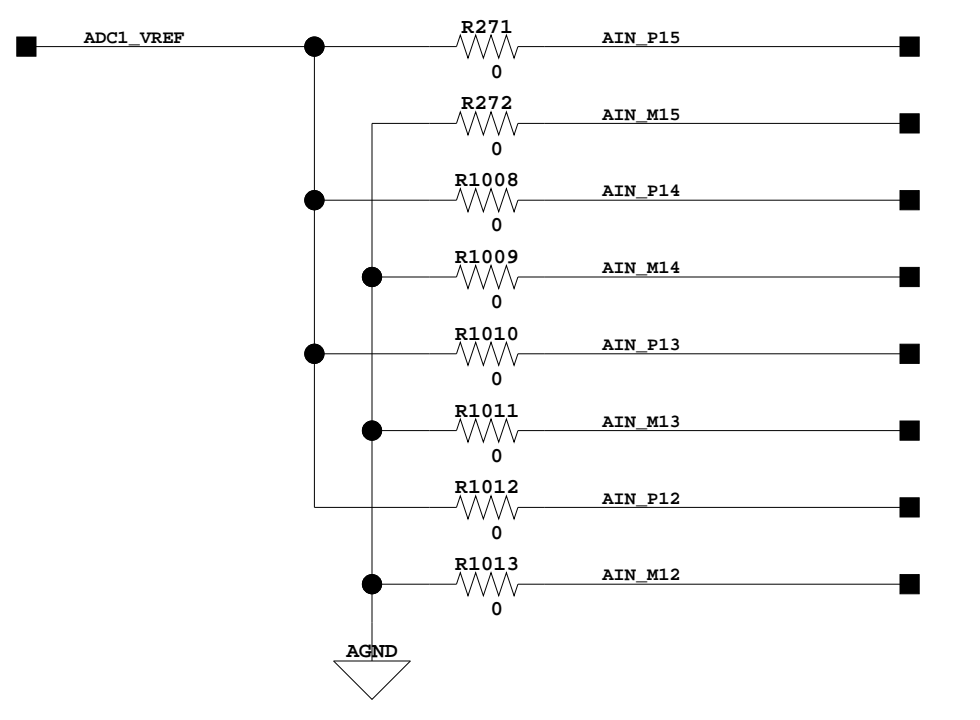
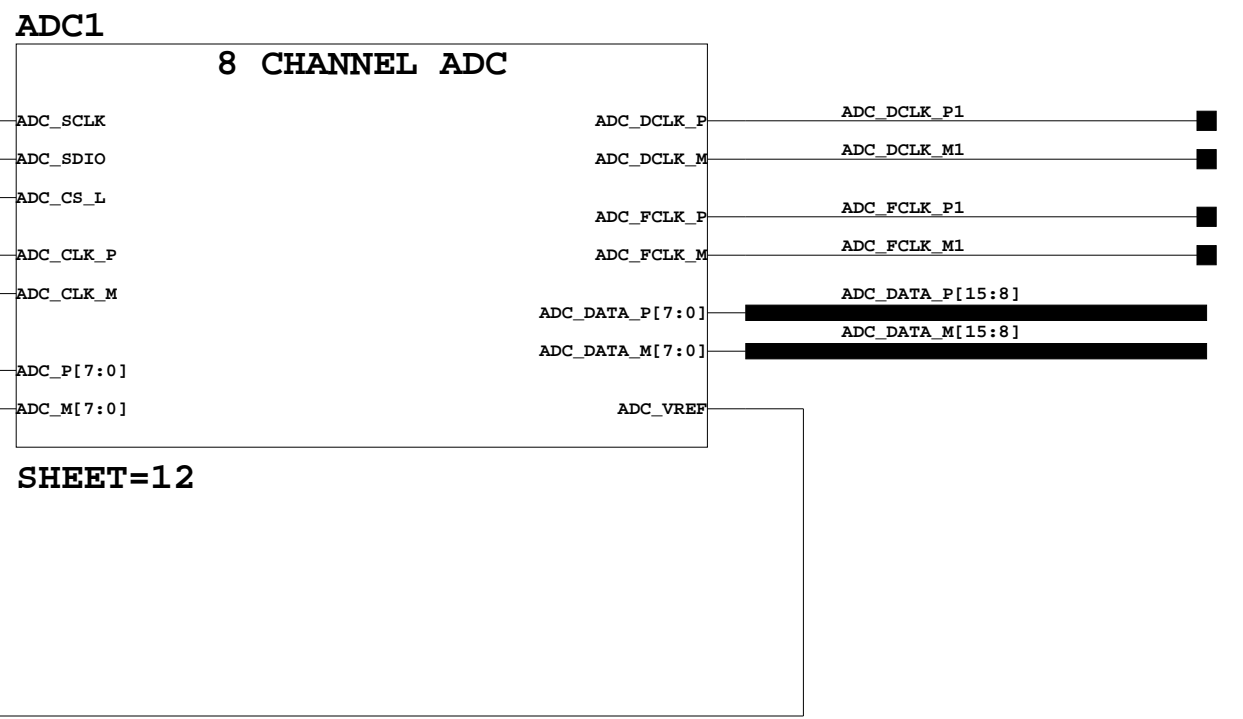
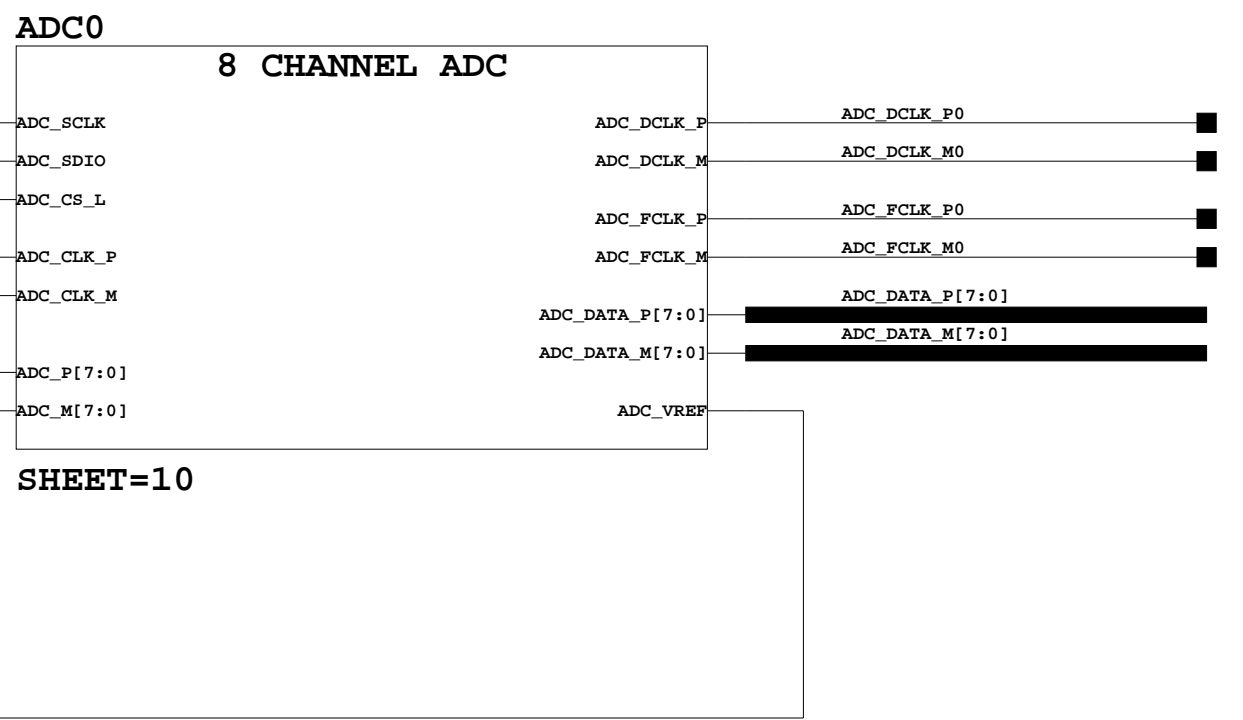
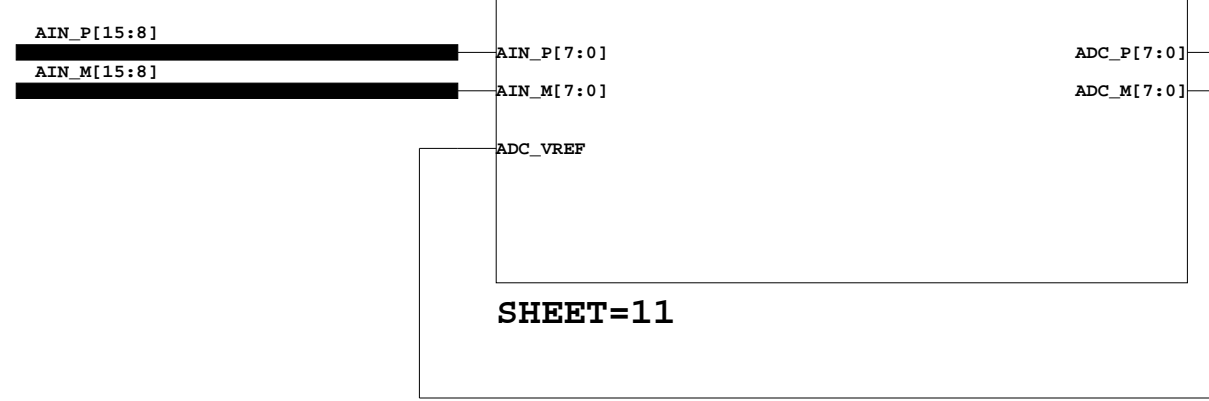
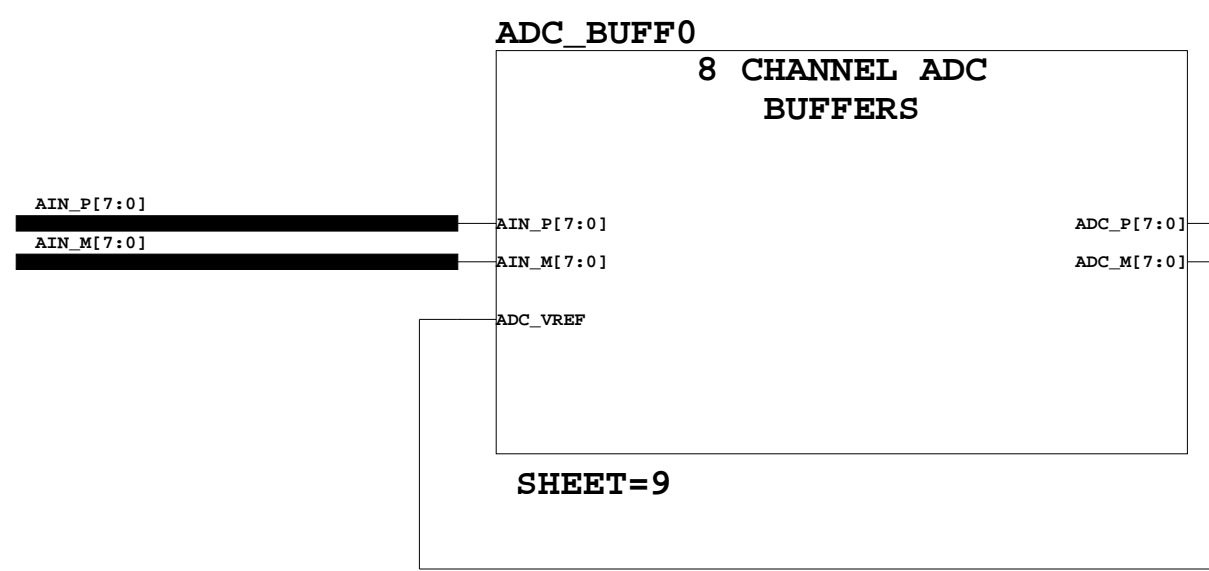
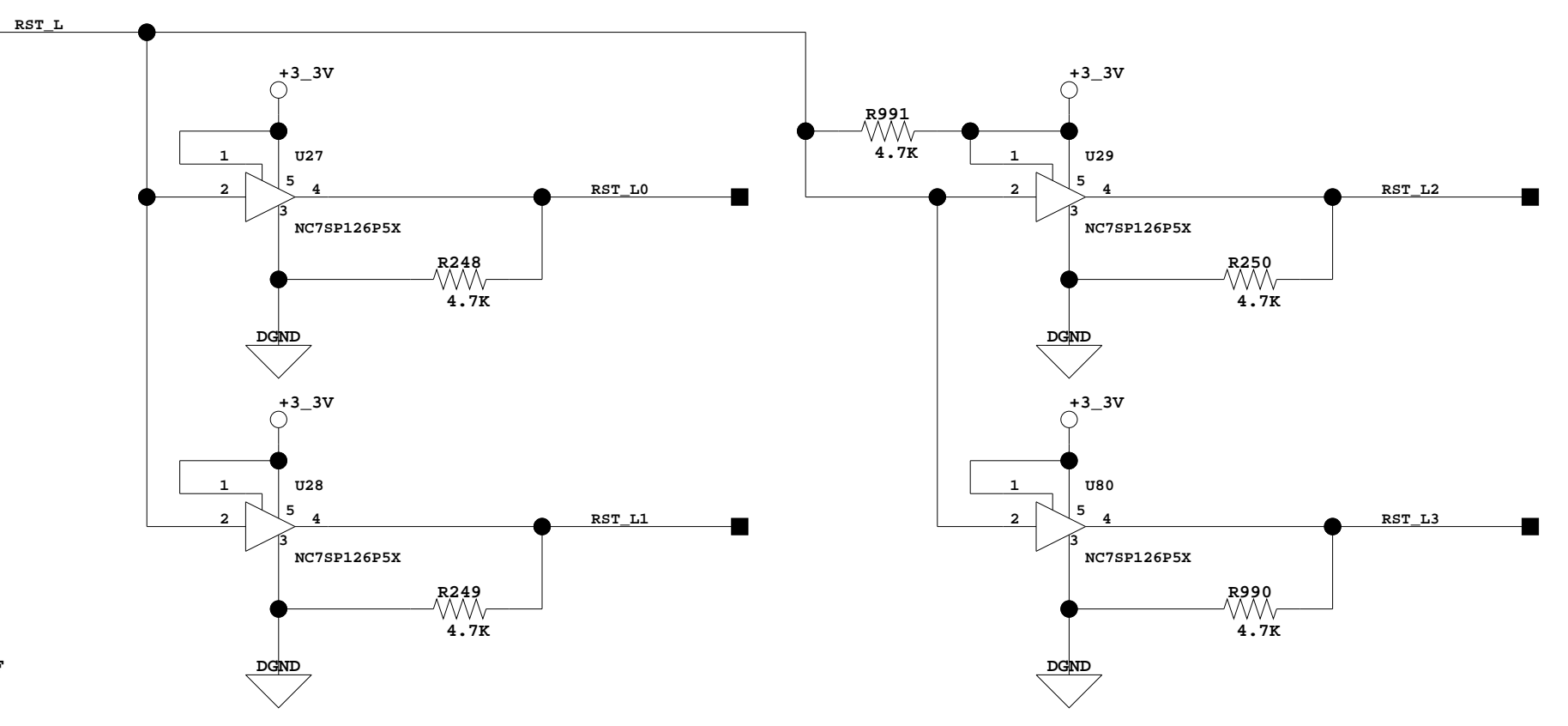
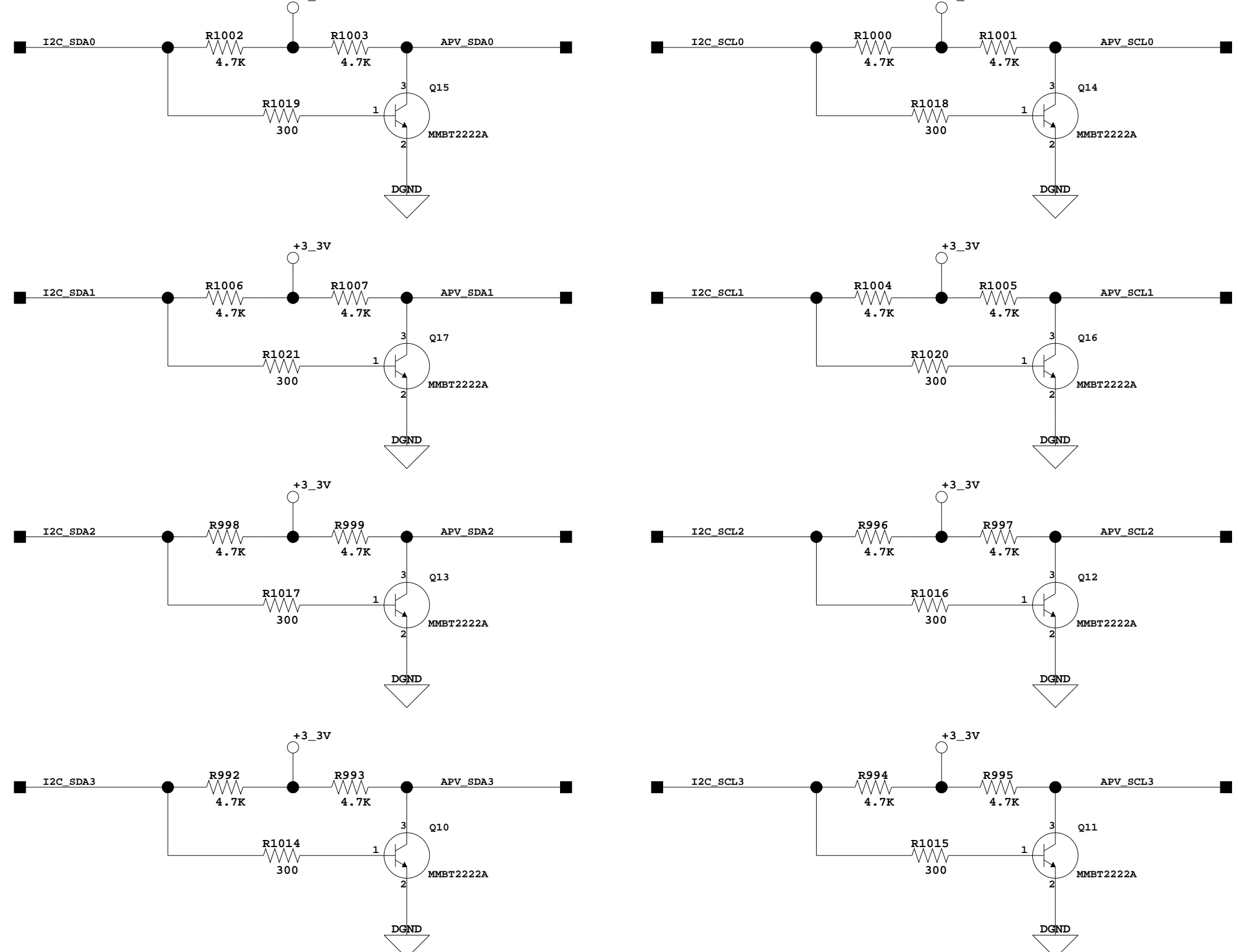

ADC\_DCLK\_P[11:0]  
ADC\_DCLK\_M[11:0]  
ADC\_SCLK\_P[11:0]  
ADC\_SCLK\_M[11:0]  
ADC\_FCLK\_P[11:0]  
ADC\_FCLK\_M[11:0]  
ADC\_DATA\_P[15:0]  
ADC\_DATA\_M[15:0]

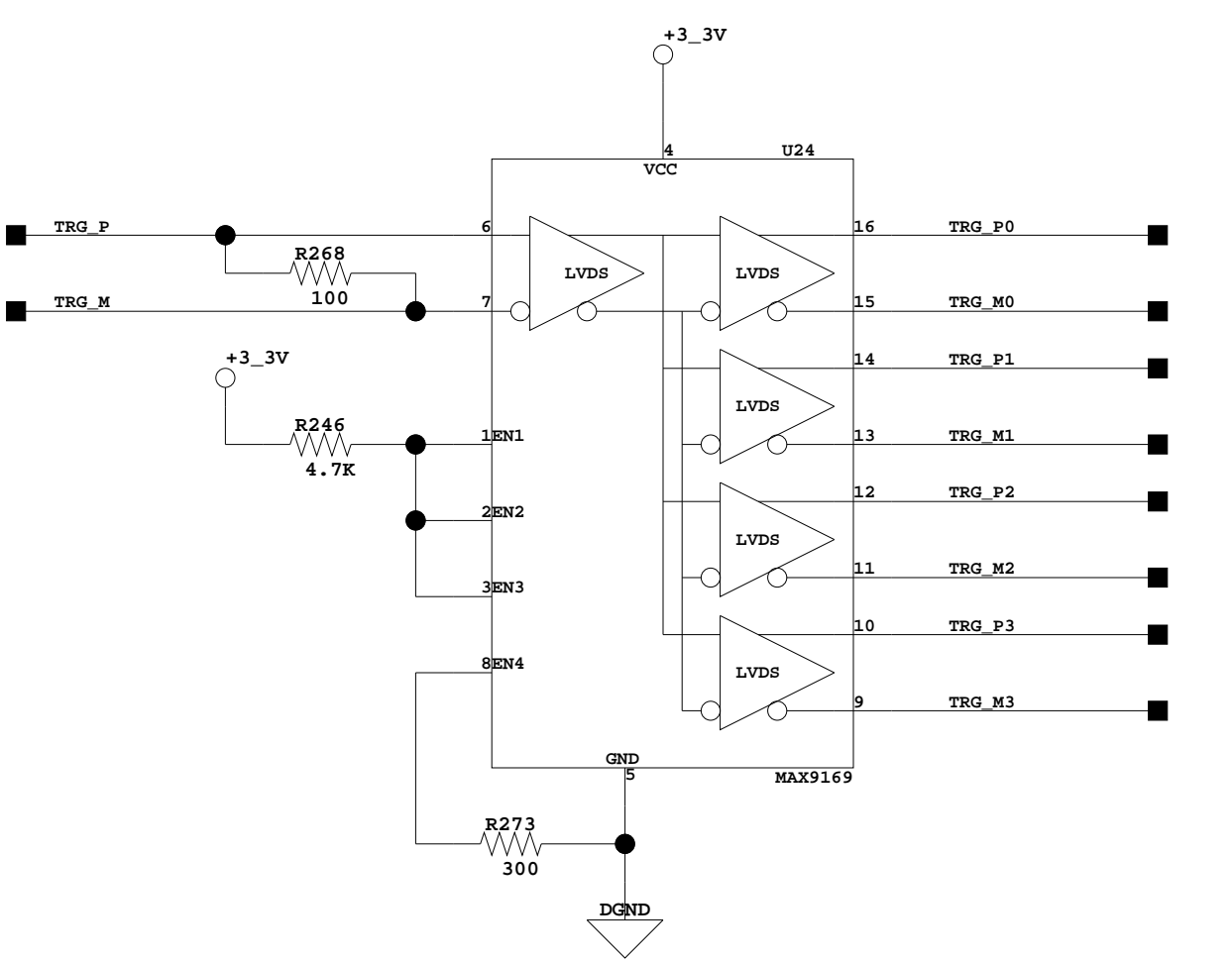
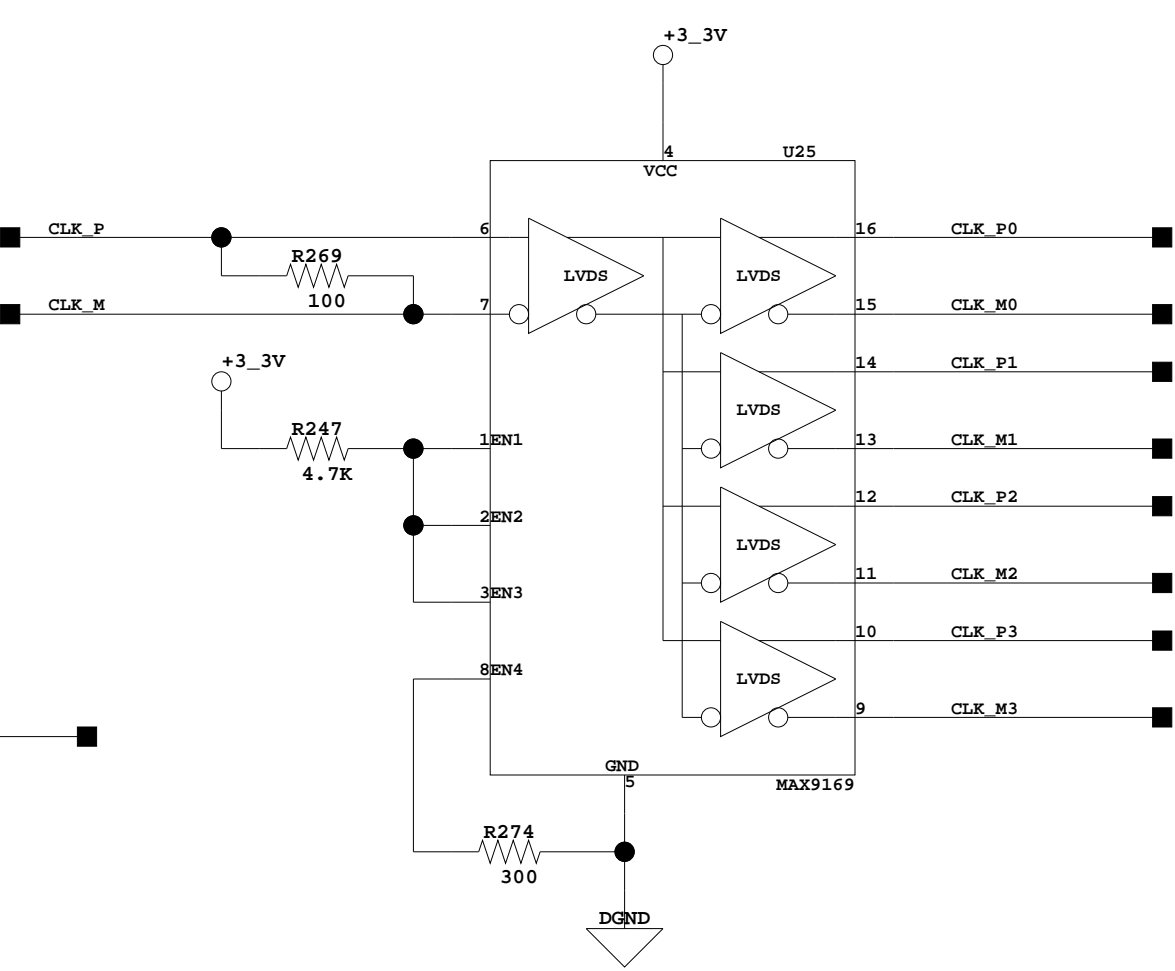

SLAC NATIONAL ACCELERATOR LABORATORY  
U.S. DEPARTMENT OF ENERGY

STANFORD UNIVERSITY STANFORD, CALIFORNIA

PROPRIETARY DATA OF STANFORD UNIVERSITY AND/OR U.S. DEPARTMENT OF ENERGY. RECIPIENT SHALL NOT PUBLISH THE INFORMATION WITHIN UNLESS GRANTED SPECIFIC PERMISSION OF STANFORD UNIVERSITY.

DATE	APPROVALS
2010	Ryan Herbst

SHEET 8 OF 23

HEAVY P TRACKER READOUT RTM  
APV25 CONNECTOR

LOCATED AT SHEET 1

SD-249-901-02-C01

1-24-2011\_15:40

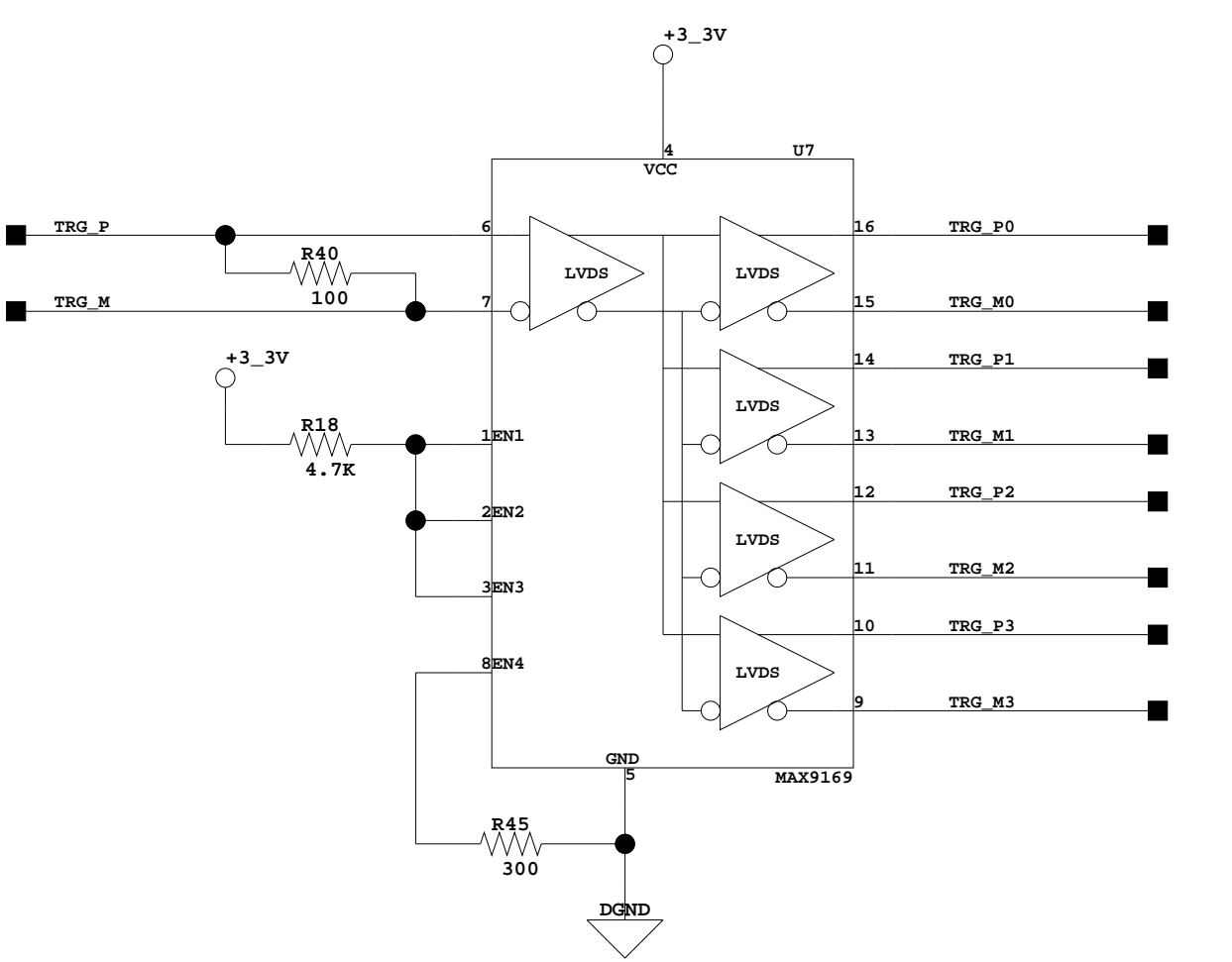
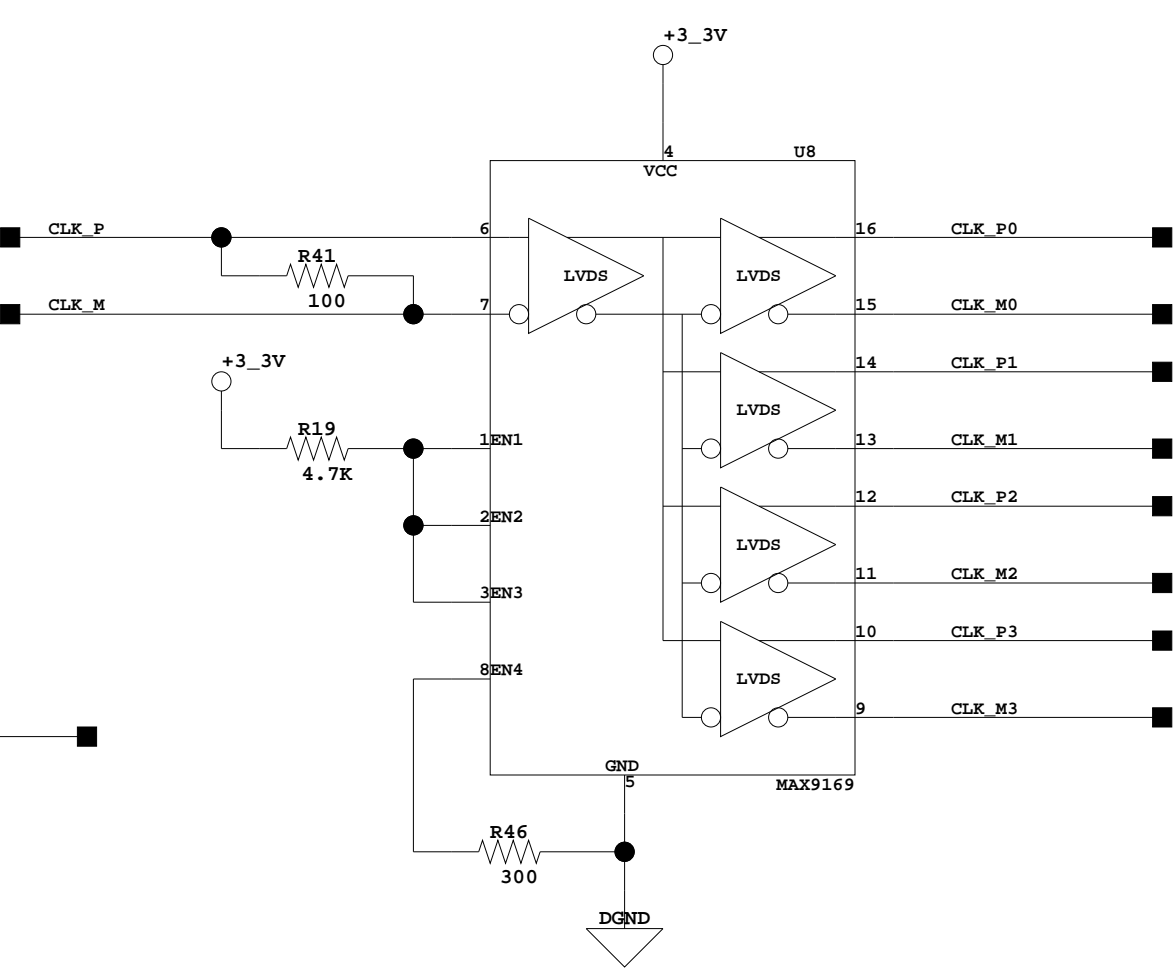
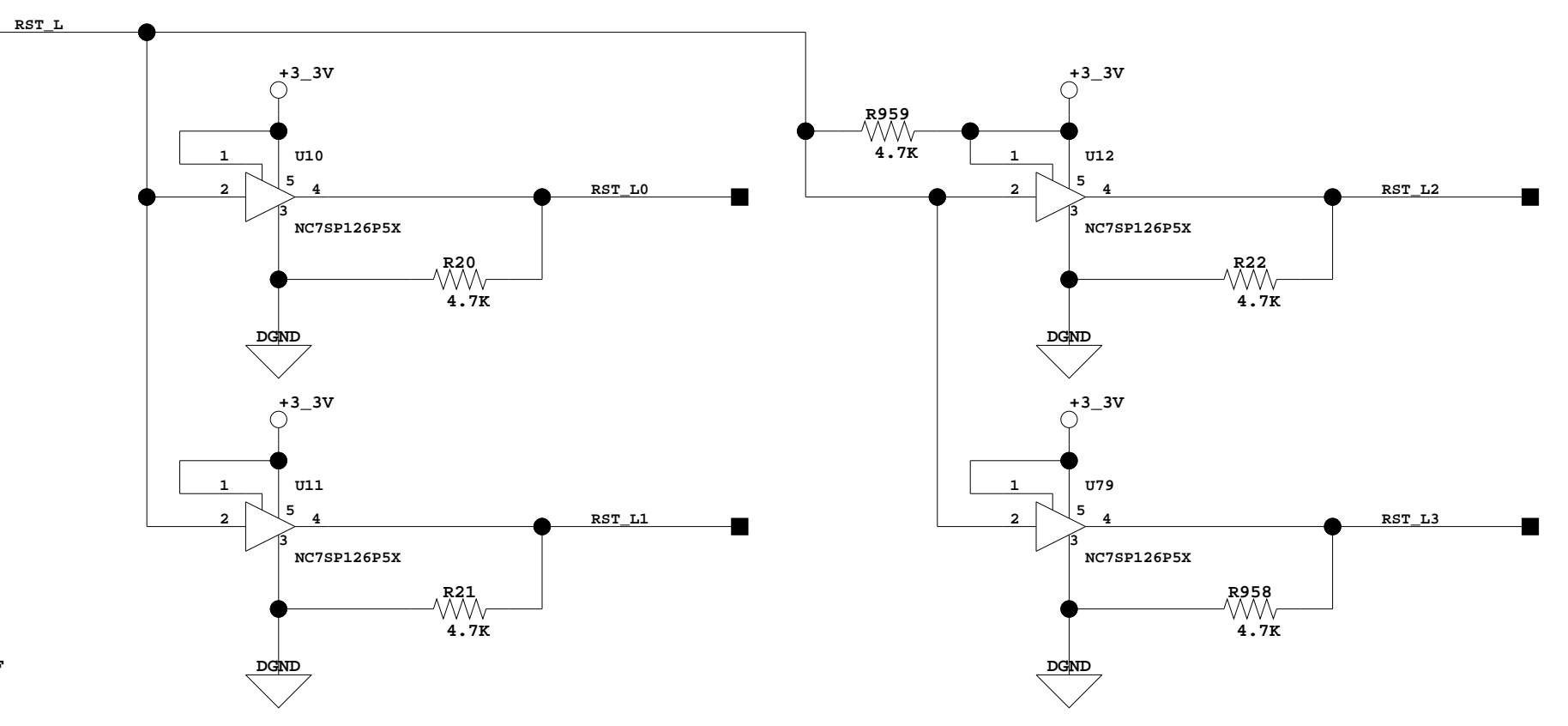
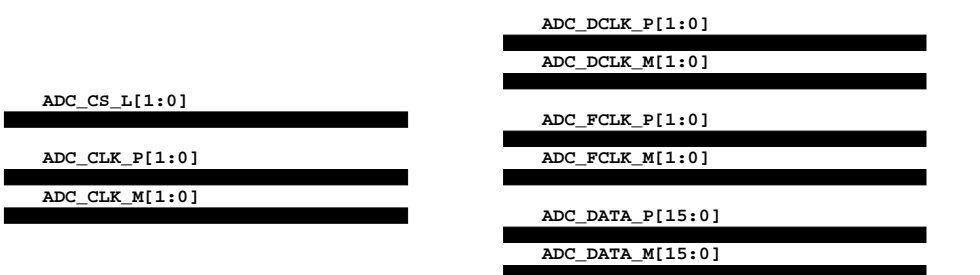
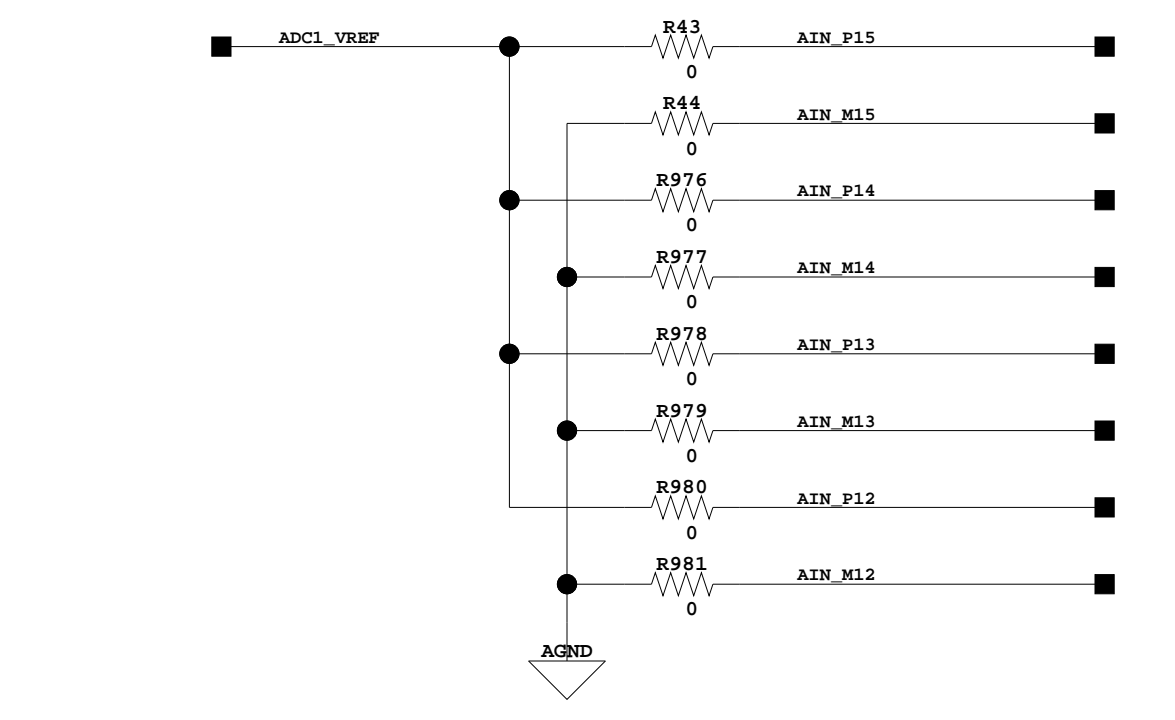
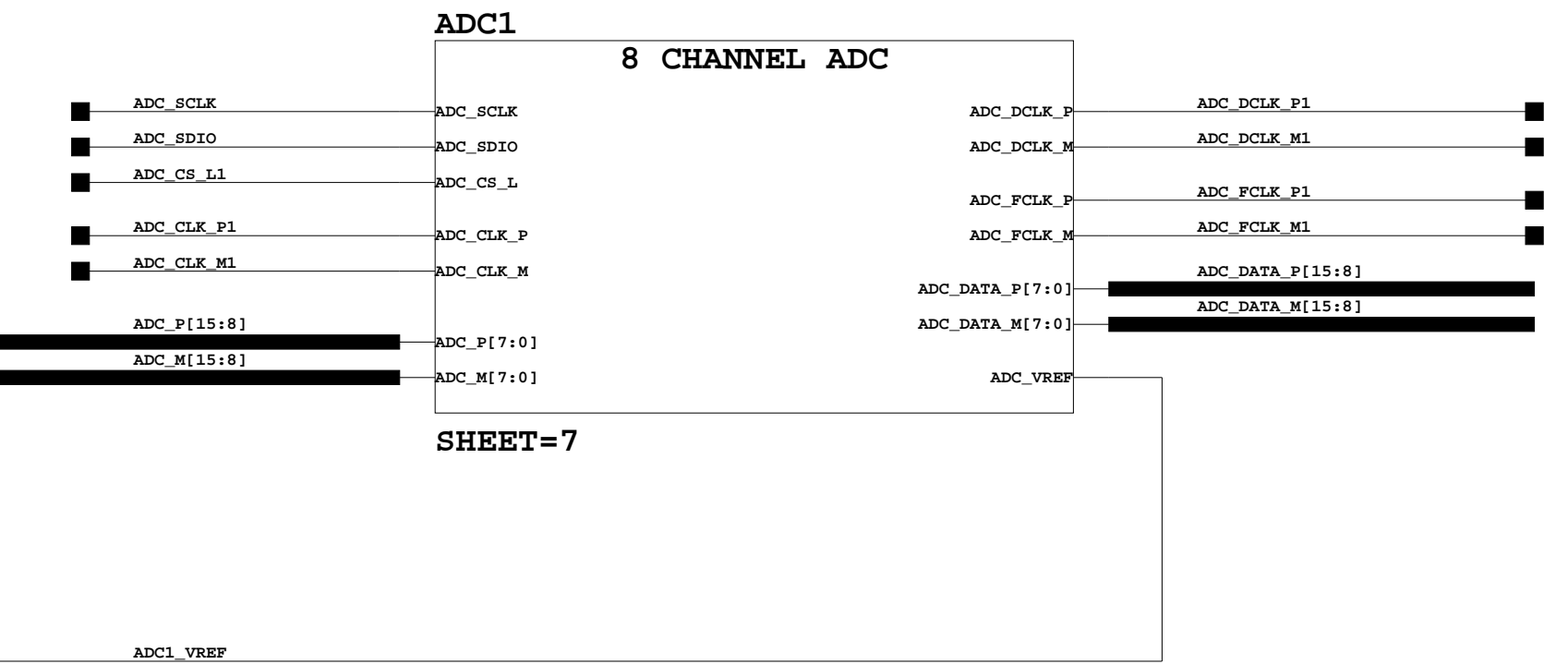
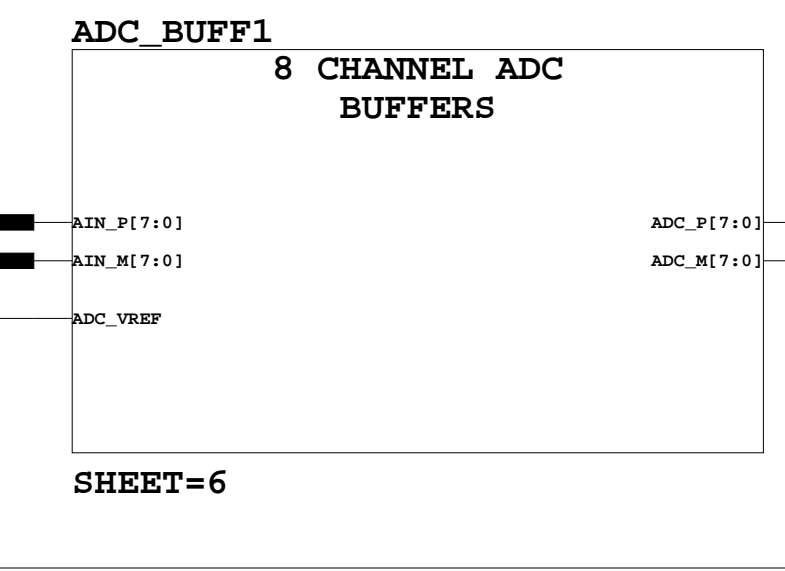
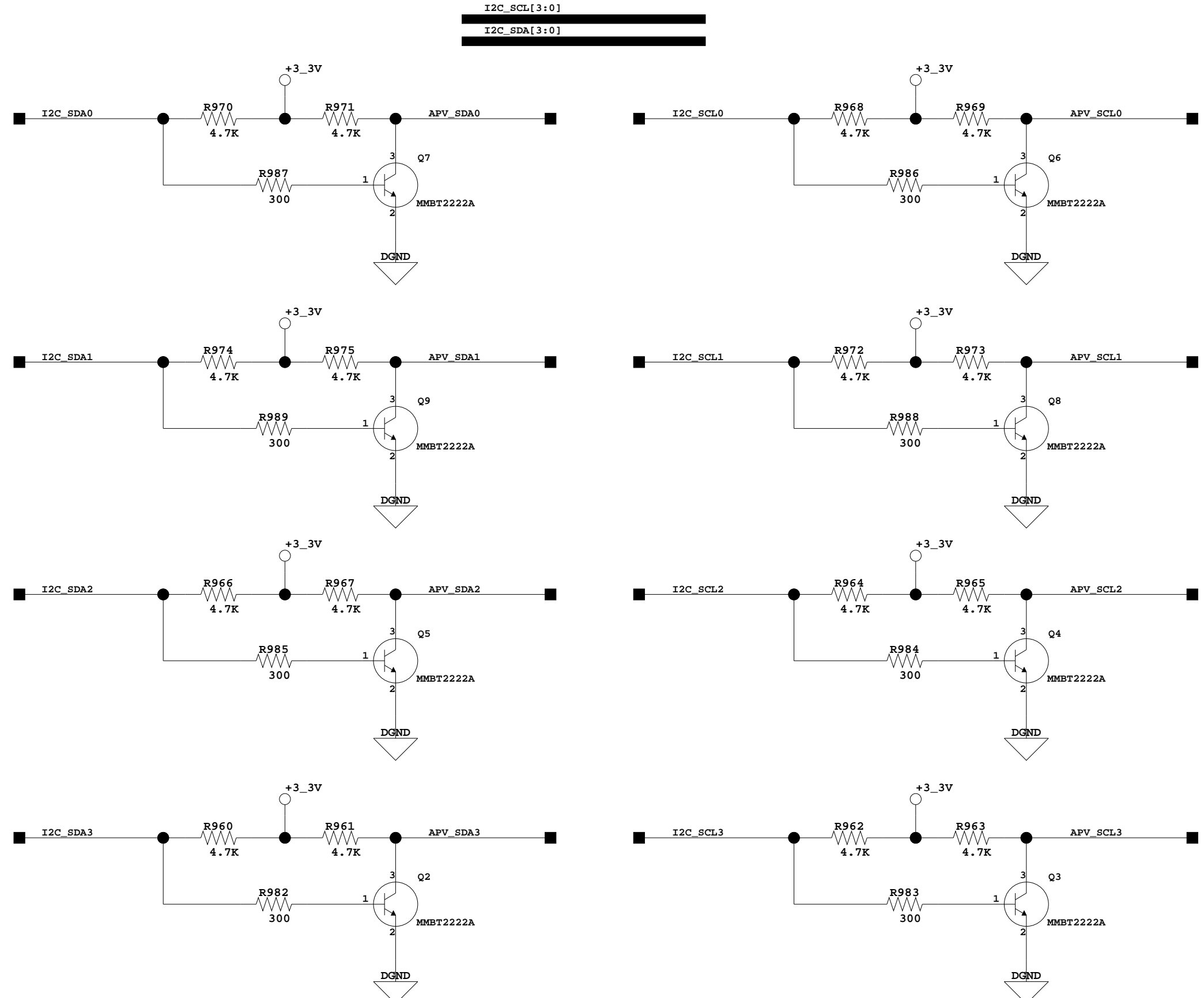
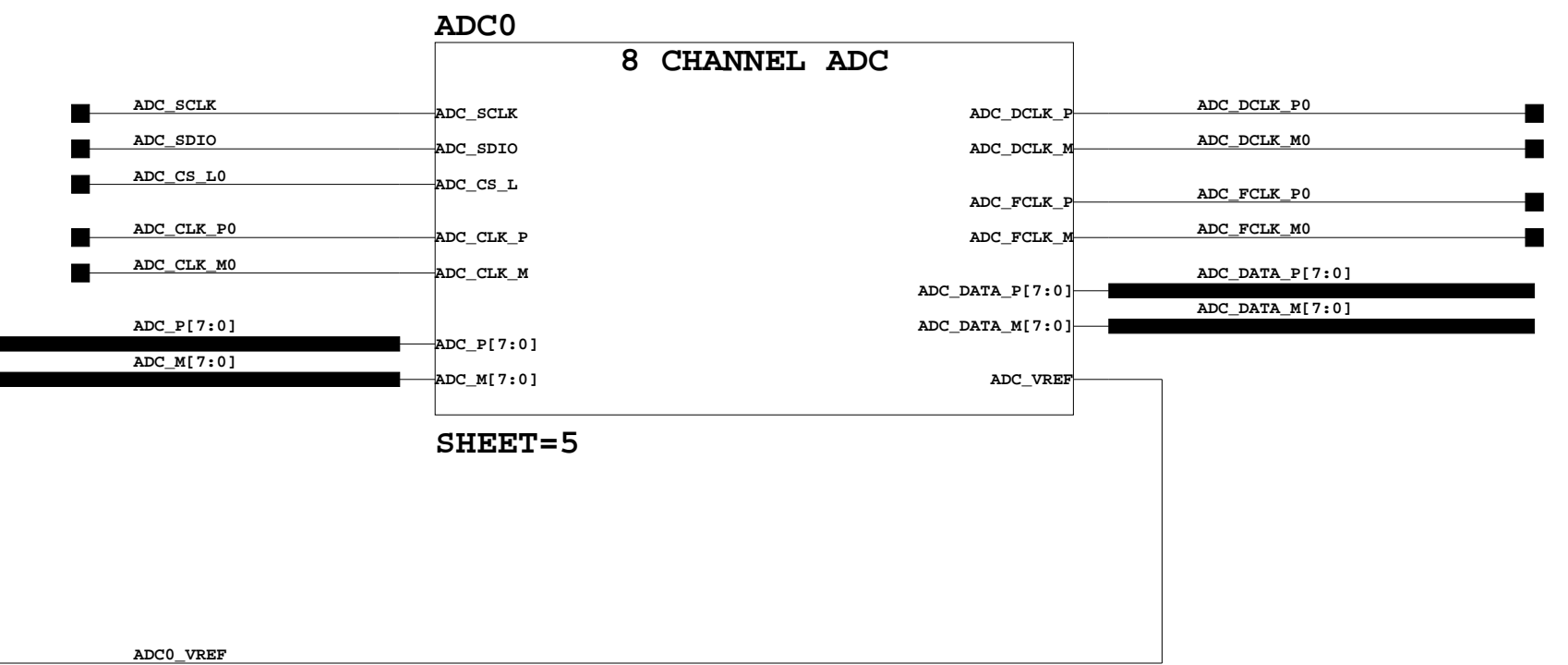
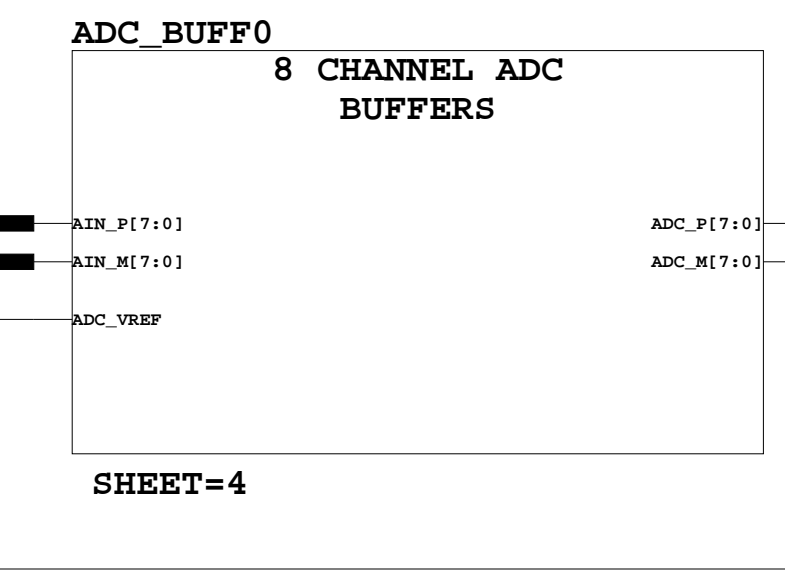
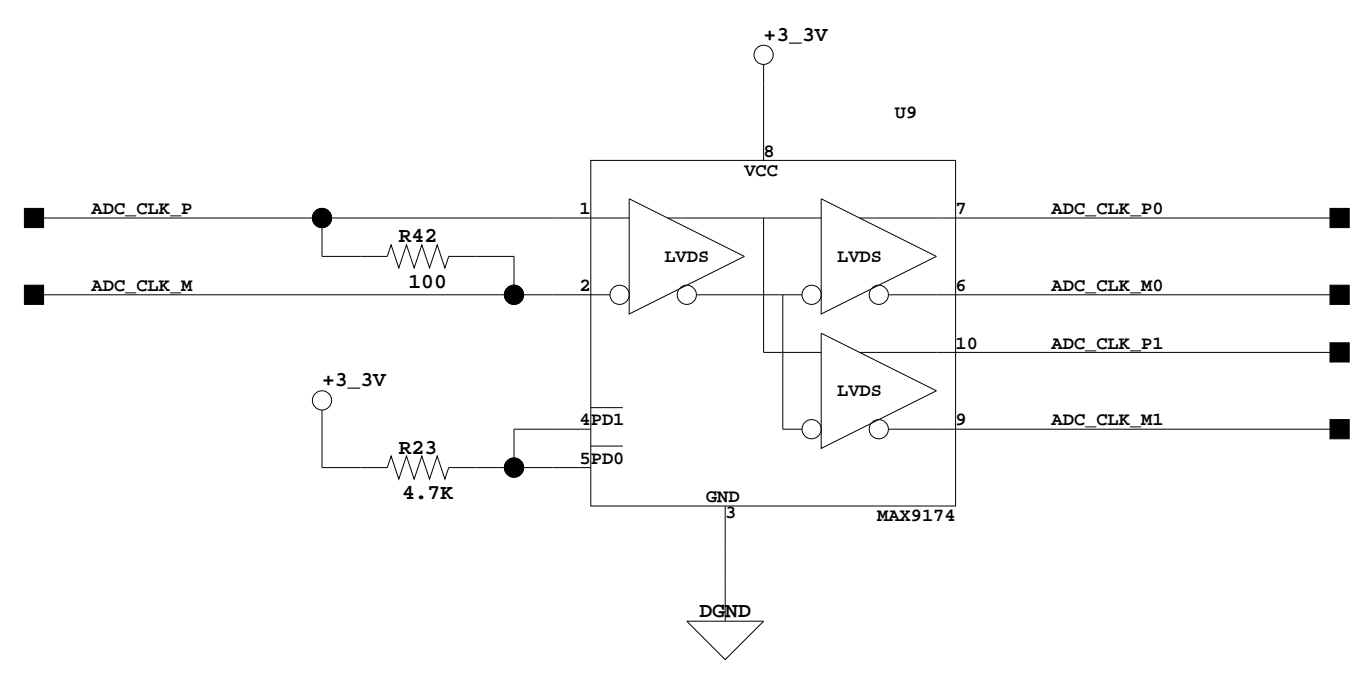
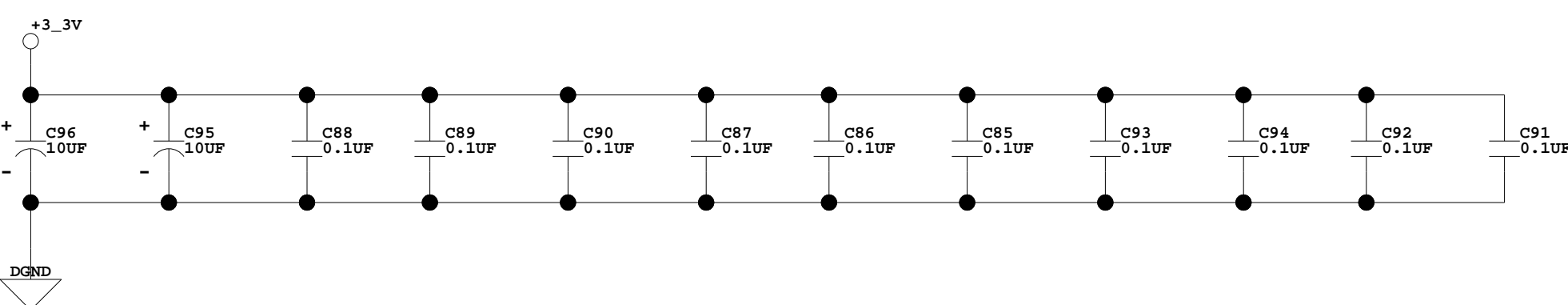
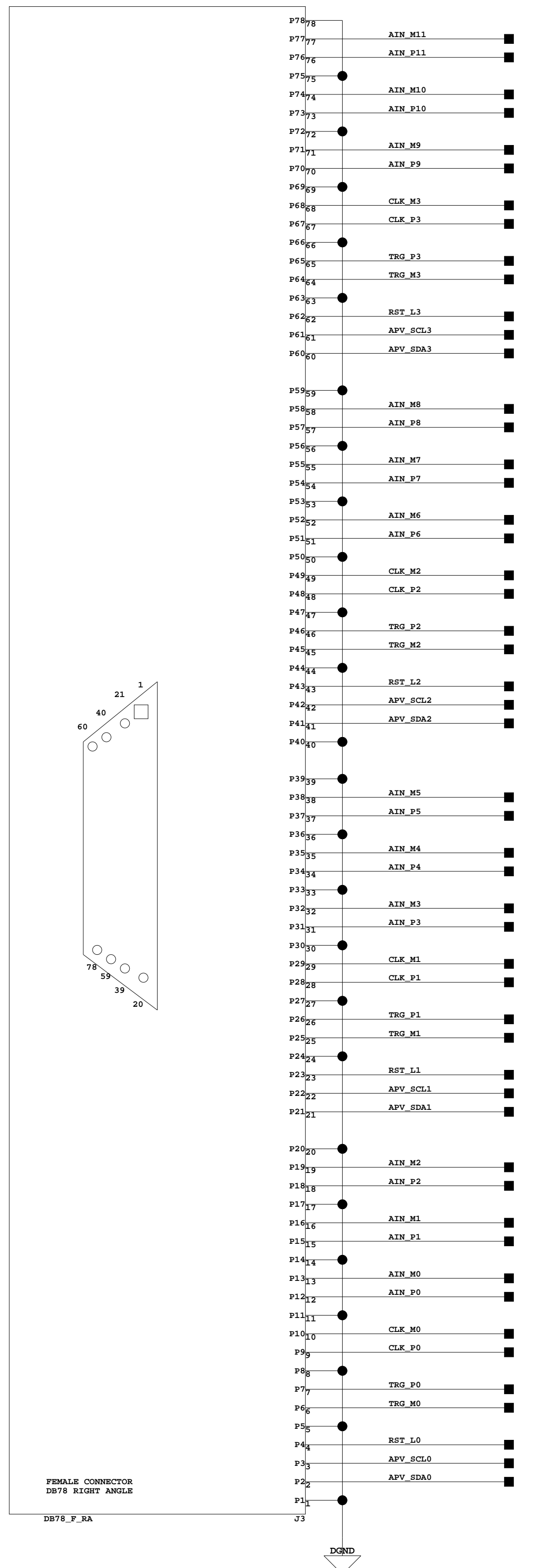

SLAC NATIONAL ACCELERATOR LABORATORY  
U.S. DEPARTMENT OF ENERGY

STANFORD UNIVERSITY STANFORD, CALIFORNIA

PROPRIETARY DATA OF STANFORD UNIVERSITY AND/OR U.S. DEPARTMENT OF ENERGY. RECIPIENT SHALL NOT PUBLISH THE INFORMATION WITHIN UNLESS GRANTED SPECIFIC PERMISSION OF STANFORD UNIVERSITY.

DATE	APPROVALS
2010	Ryan Herbat

SHEET 3 OF 23

HEAVY P TRACKER READOUT RTM  
APV25 CONNECTOR

LOCATED AT SHEET 1

SD-249-901-02-C01

1-24-2011\_15:40

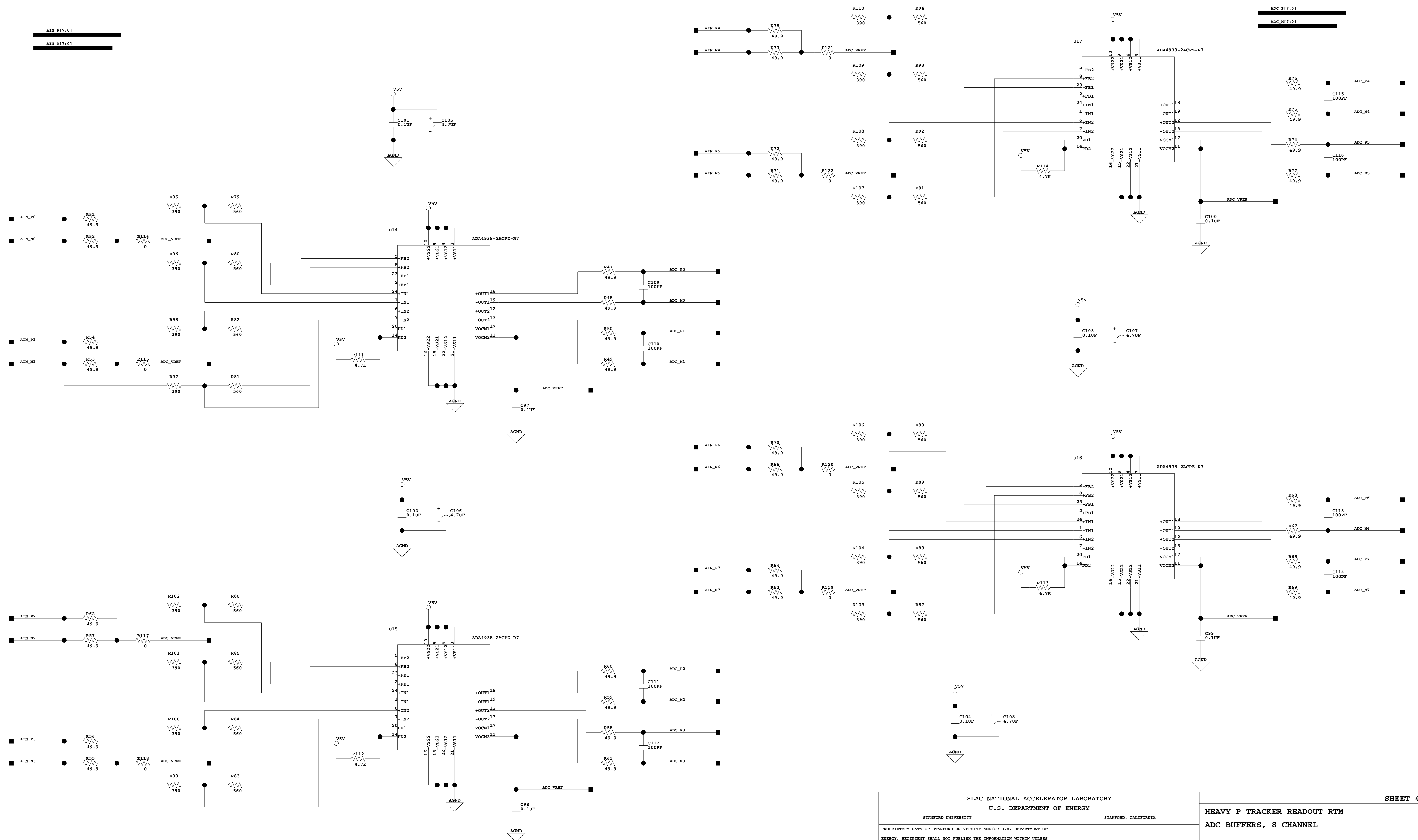

1-24-2011\_15:38

**SLAC NATIONAL ACCELERATOR LABORATORY**  
**U.S. DEPARTMENT OF ENERGY**

STANFORD UNIVERSITY STANFORD, CALIFORNIA

PROPRIETARY DATA OF STANFORD UNIVERSITY AND/OR U.S. DEPARTMENT OF ENERGY. RECIPIENT SHALL NOT PUBLISH THE INFORMATION WITHIN UNLESS GRANTED SPECIFIC PERMISSION OF STANFORD UNIVERSITY.

INDR	DATE	APPROVALS
Ryan Herbat	2010	
DFR		
CDR		

SHEET 4 OF 23

**HEAVY P TRACKER READOUT RTM**  
**ADC BUFFERS, 8 CHANNEL**

LOCATED AT SHEET 3  
 SD-249-901-02-C01

ADC INPUT TERMINATION  
PLACE NEAR ADC

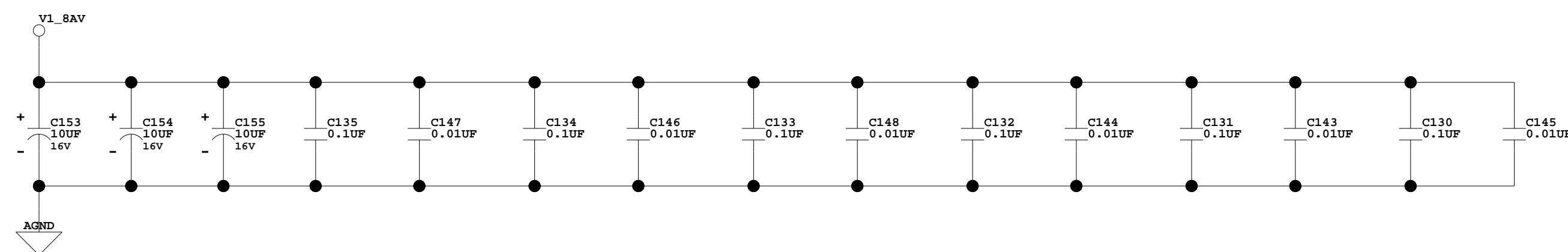
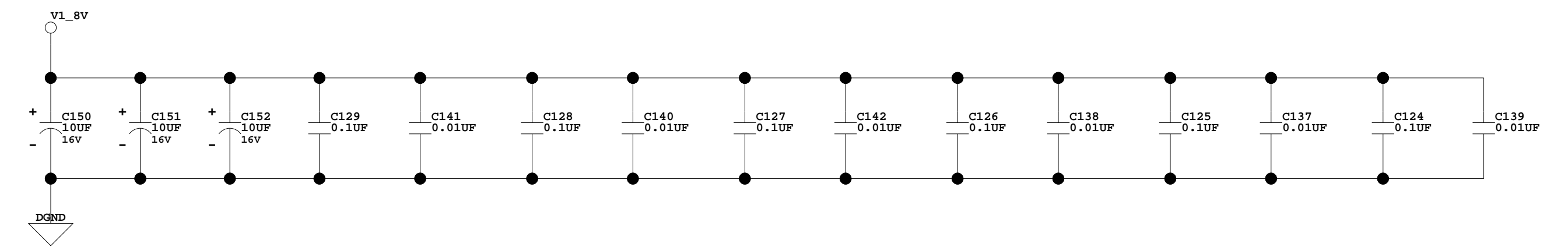
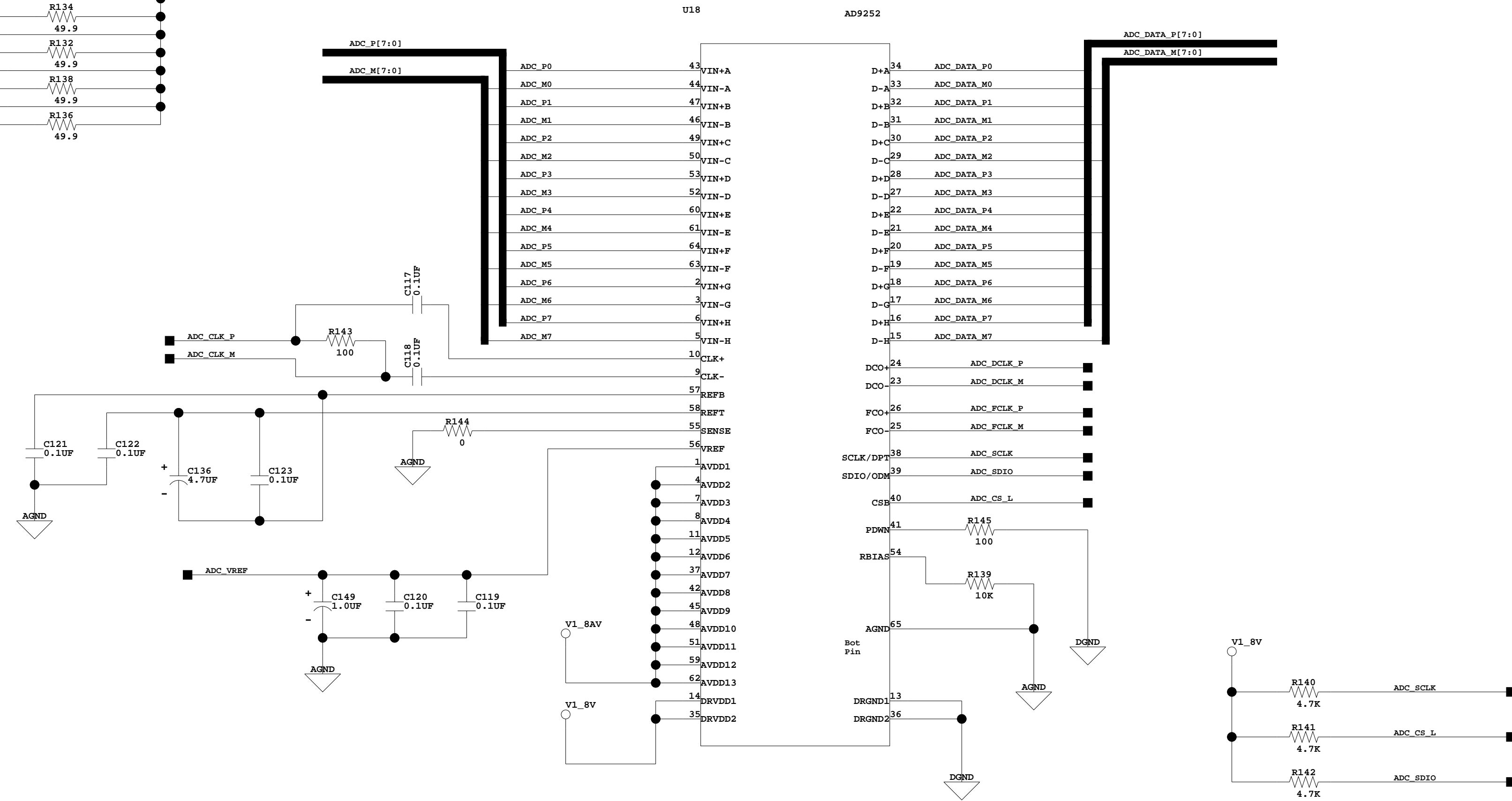
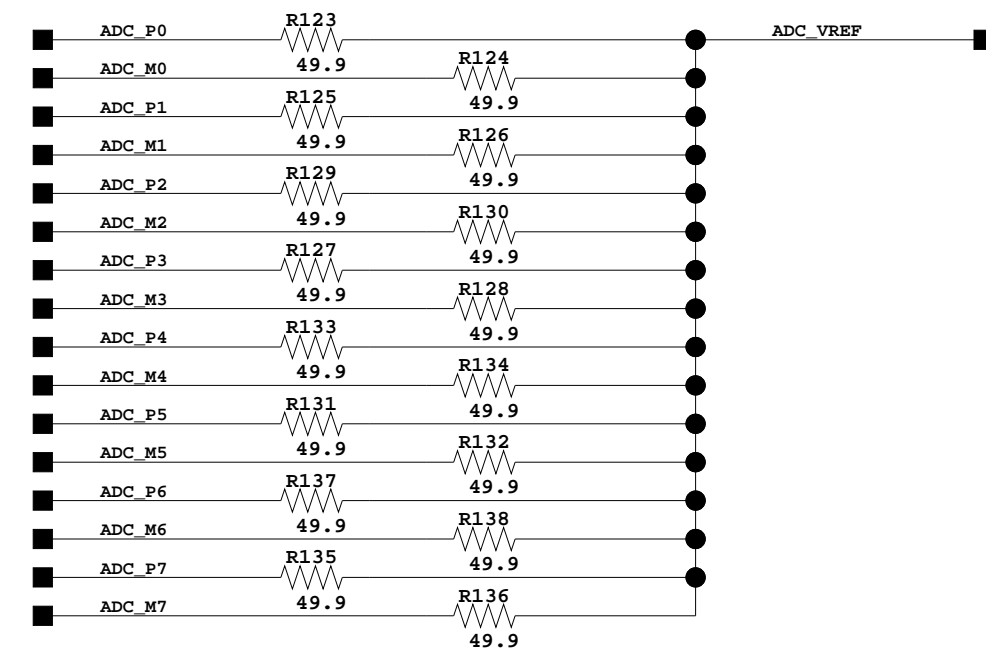

1-24-2011\_15:38

SLAC NATIONAL ACCELERATOR LABORATORY U.S. DEPARTMENT OF ENERGY		SHEET 5 OF 23
STANFORD UNIVERSITY STANFORD, CALIFORNIA		HEAVY P TRACKER READOUT RTM 8 CHANNEL ADC
PROPRIETARY DATA OF STANFORD UNIVERSITY AND/OR U.S. DEPARTMENT OF ENERGY. RECIPIENT SHALL NOT PUBLISH THE INFORMATION WITHIN UNLESS GRANTED SPECIFIC PERMISSION OF STANFORD UNIVERSITY.		
INGR	Ryan Herbst	DATE
DPTH		APPROVALS
CMR		LOCATED AT SHEET 3
		SD-249-901-02-C01

ADC INPUT TERMINATION  
PLACE NEAR ADC

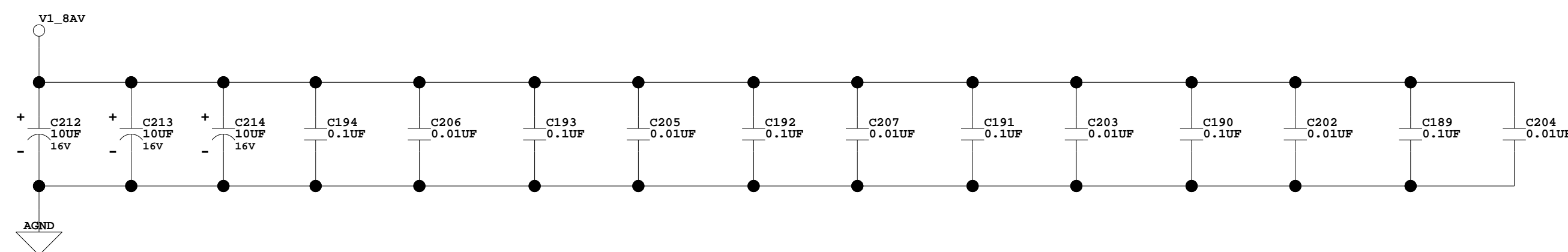
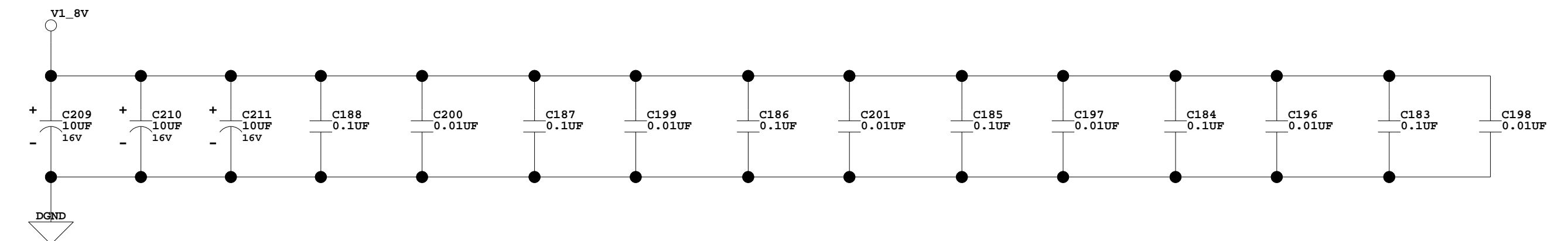
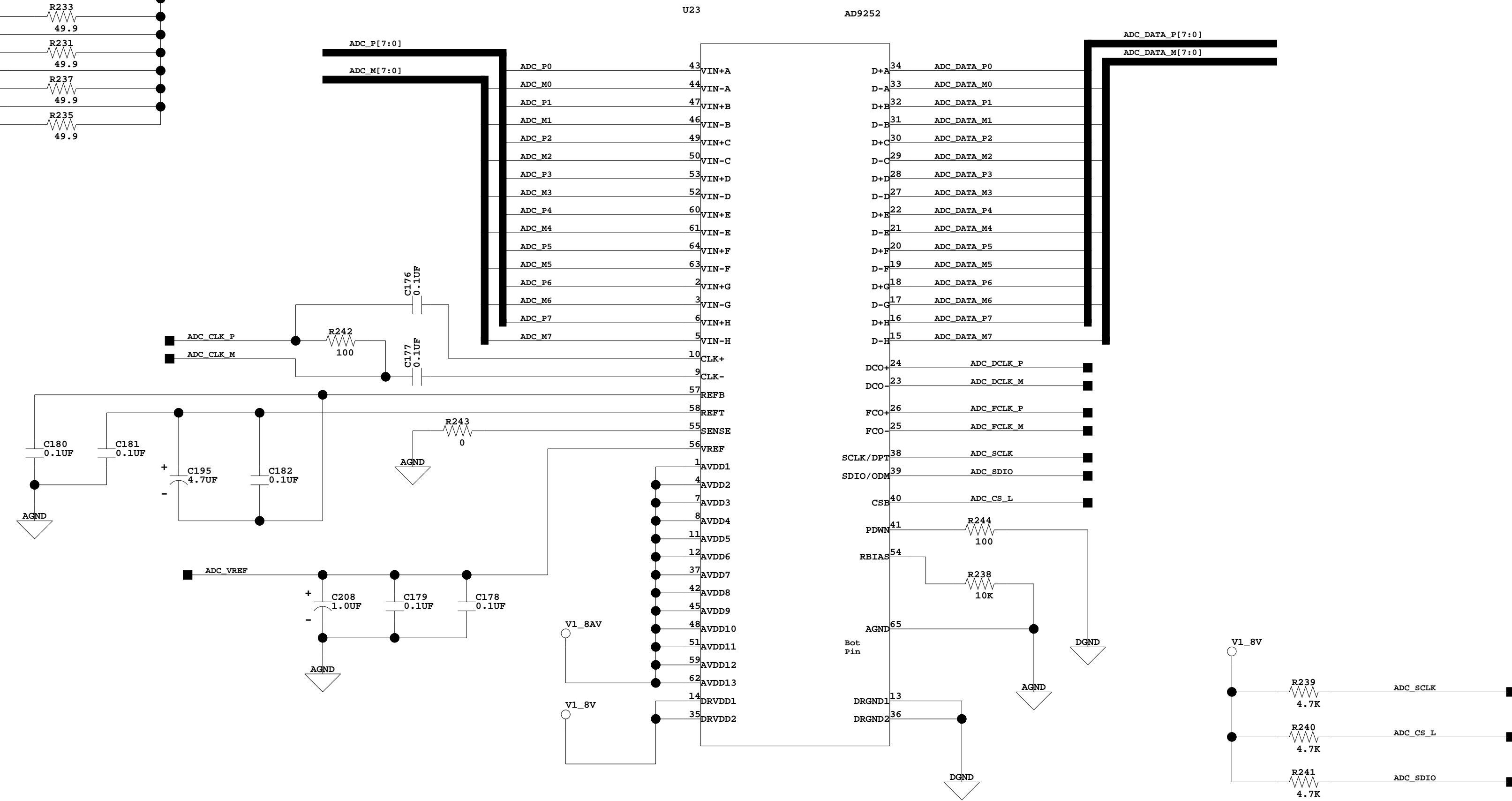
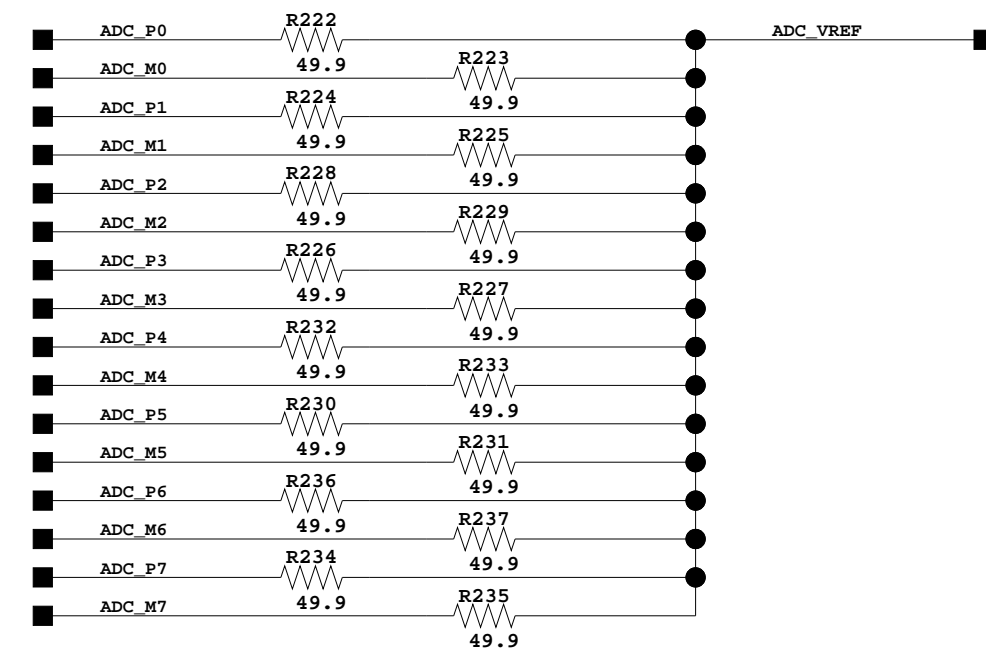

1-24-2011\_15:38

SLAC NATIONAL ACCELERATOR LABORATORY U.S. DEPARTMENT OF ENERGY		SHEET 7 OF 23
STANFORD UNIVERSITY STANFORD, CALIFORNIA		HEAVY P TRACKER READOUT RTM 8 CHANNEL ADC
PROPRIETARY DATA OF STANFORD UNIVERSITY AND/OR U.S. DEPARTMENT OF ENERGY. RECIPIENT SHALL NOT PUBLISH THE INFORMATION WITHIN UNLESS GRANTED SPECIFIC PERMISSION OF STANFORD UNIVERSITY.		
INGR	Ryan Herbst	DATE: 2010
DPTH		APPROVALS
CMR		
LOCATED AT SHEET 3		
SD-249-901-02-C01		

LEDS

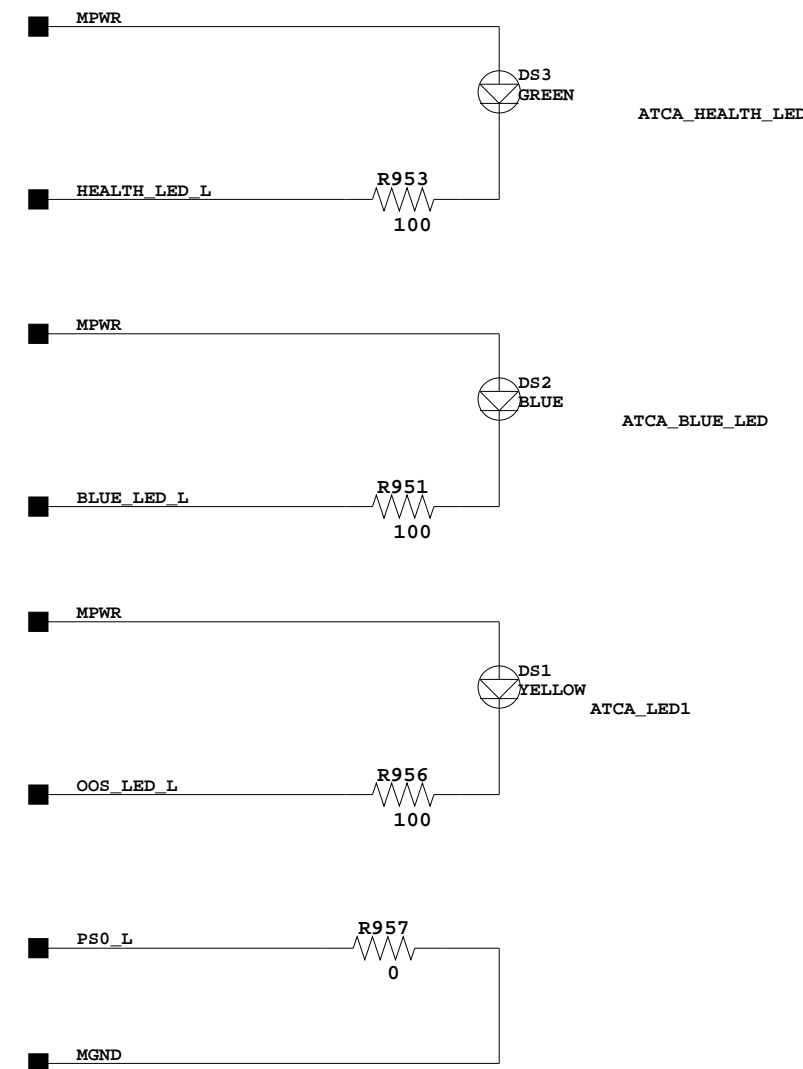

VOLTAGE MONITOR

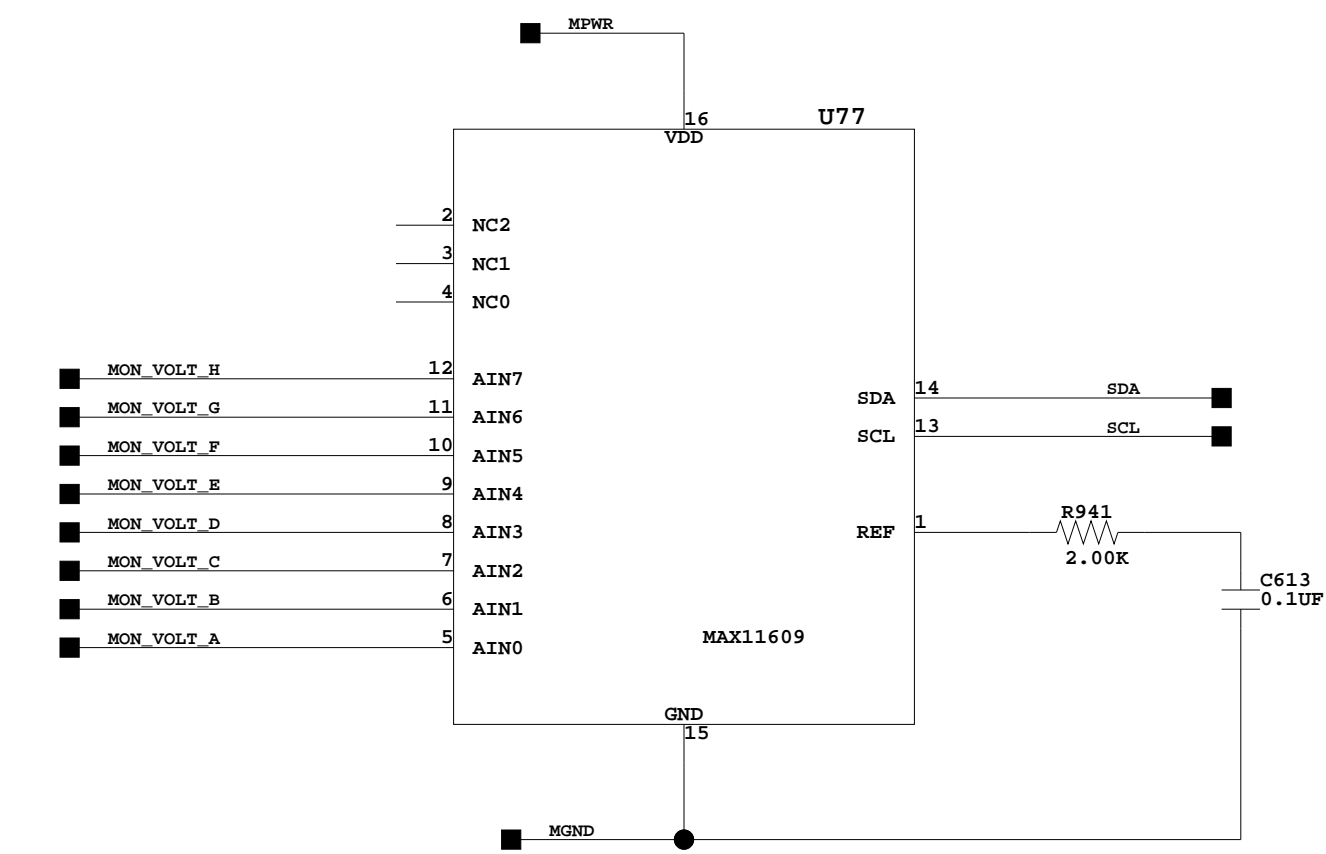

ADDR = 0x3C

TEMPERATURE SENSOR

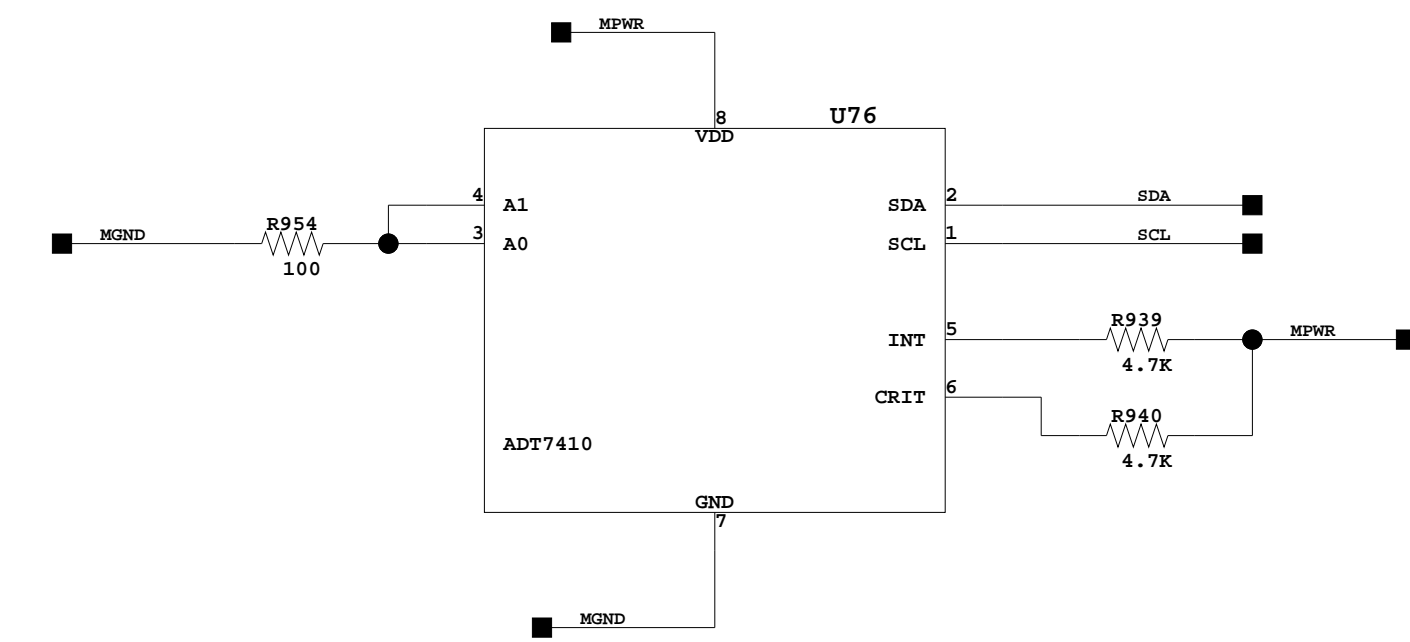

ADDR = 0x48

IO & EEPROM

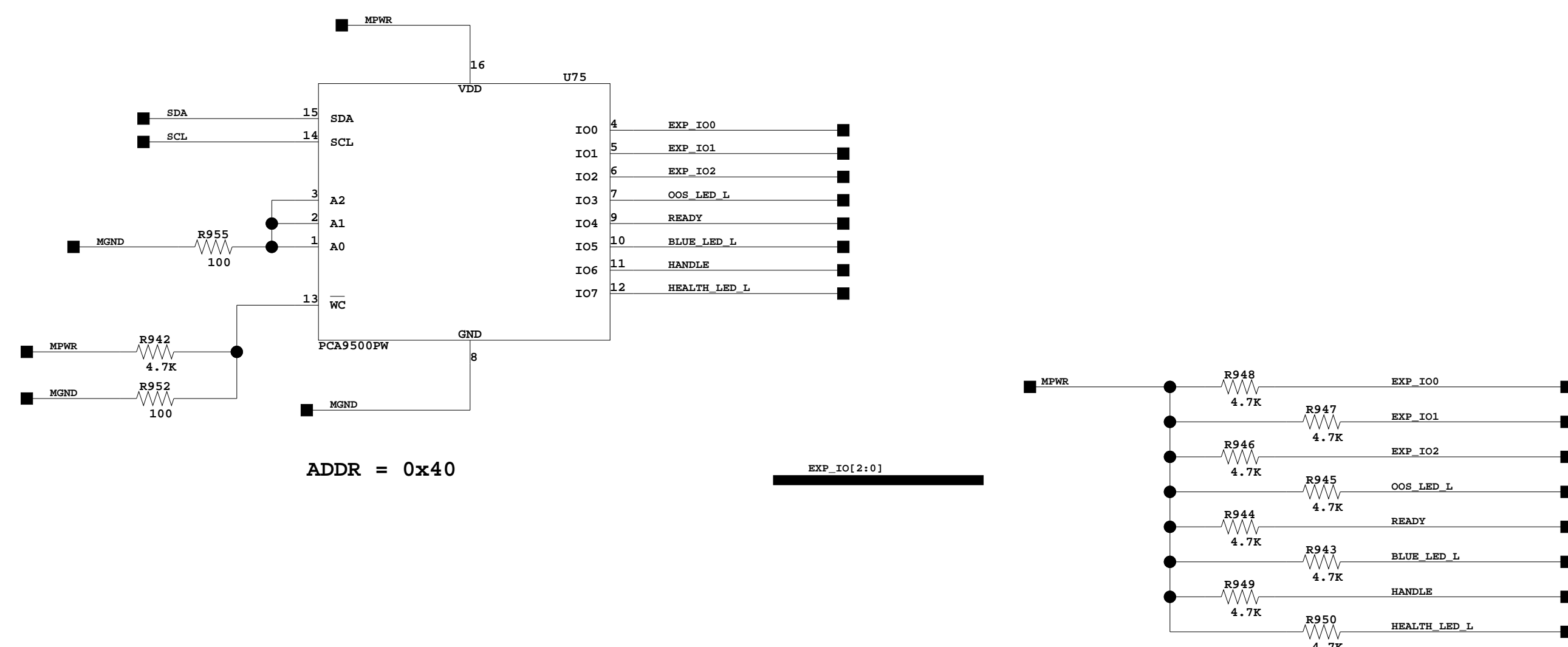

ADDR = 0x40

SERIAL ID

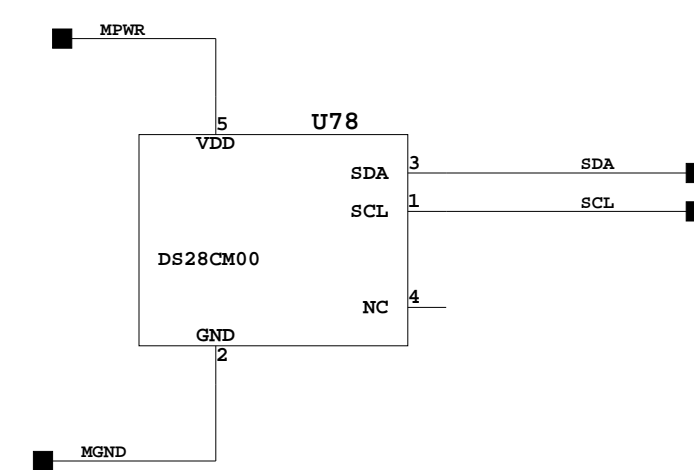

ADDR = 0x50

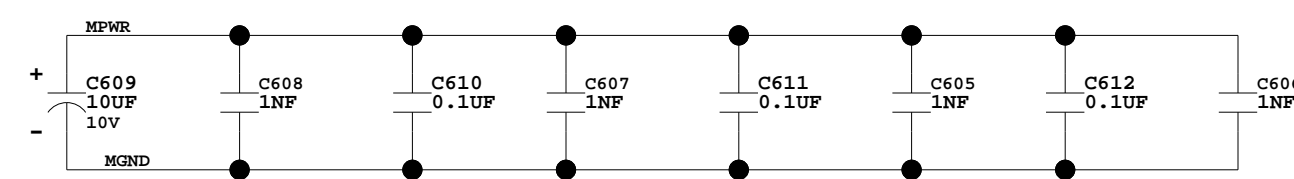

1-24-2011\_15:40

SLAC NATIONAL ACCELERATOR LABORATORY U.S. DEPARTMENT OF ENERGY			IPMB CLIENT
STANFORD UNIVERSITY	STANFORD, CALIFORNIA		
PROPRIETARY DATA OF STANFORD UNIVERSITY AND/OR U.S. DEPARTMENT OF ENERGY. RECIPIENT SHALL NOT PUBLISH THE INFORMATION WITHIN UNLESS GRANTED SPECIFIC PERMISSION OF STANFORD UNIVERSITY.			
ENGR	Ryan Herbat	DATE	2010
DFTS		APPROVALS	
CDRS			



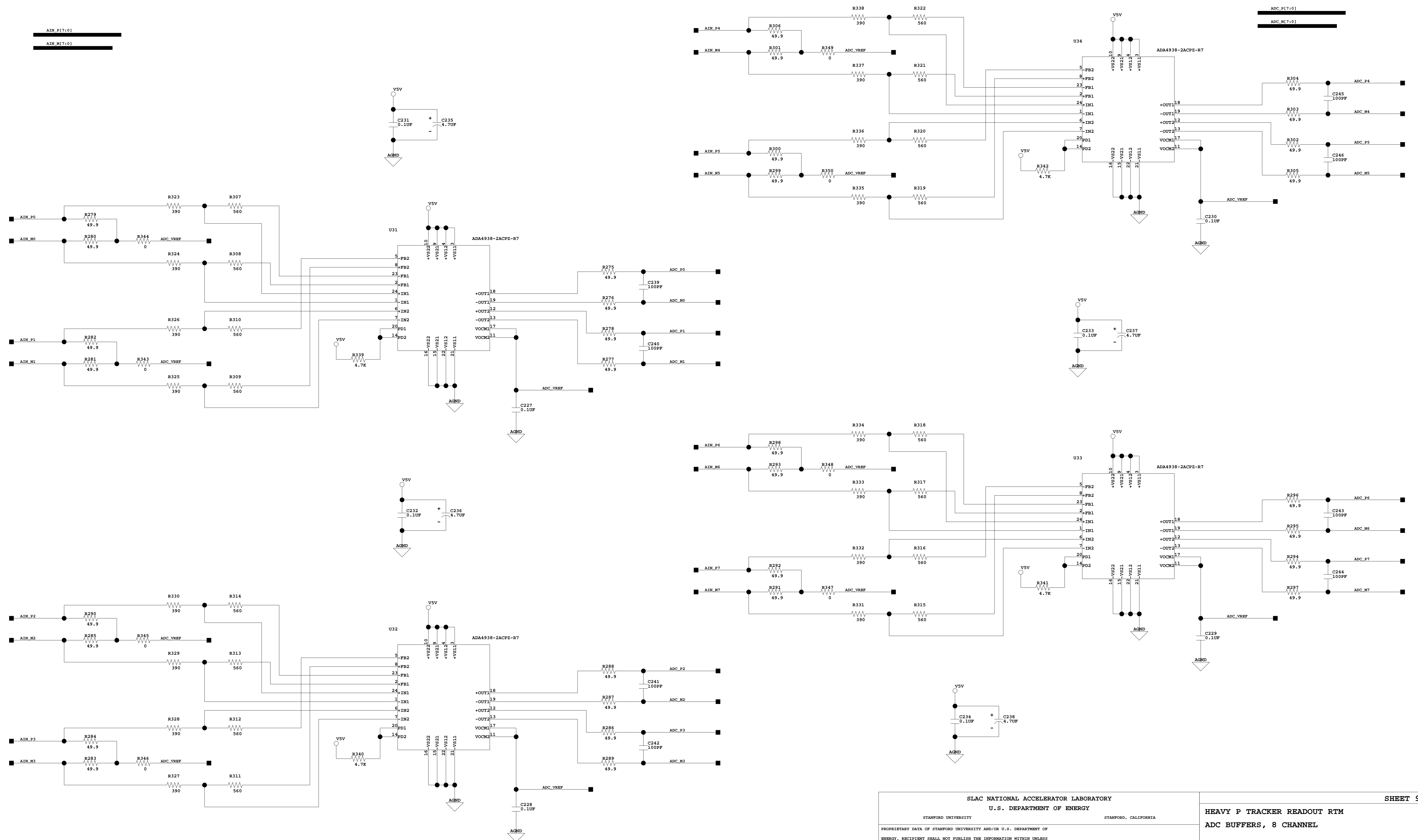

1-24-2011\_15:38

SLAC NATIONAL ACCELERATOR LABORATORY U.S. DEPARTMENT OF ENERGY	
STANFORD UNIVERSITY	STANFORD, CALIFORNIA
PROPRIETARY DATA OF STANFORD UNIVERSITY AND/OR U.S. DEPARTMENT OF ENERGY. RECIPIENT SHALL NOT PUBLISH THE INFORMATION WITHIN UNLESS GRANTED SPECIFIC PERMISSION OF STANFORD UNIVERSITY.	
INDR	DATE
DFR	APPROVALS
CDR	

SHEET 9 OF 23

**HEAVY P TRACKER READOUT RTM  
ADC BUFFERS, 8 CHANNEL**

LOCATED AT SHEET 8  
SD-249-901-02-C01

**ADC INPUT TERMINATION  
PLACE NEAR ADC**

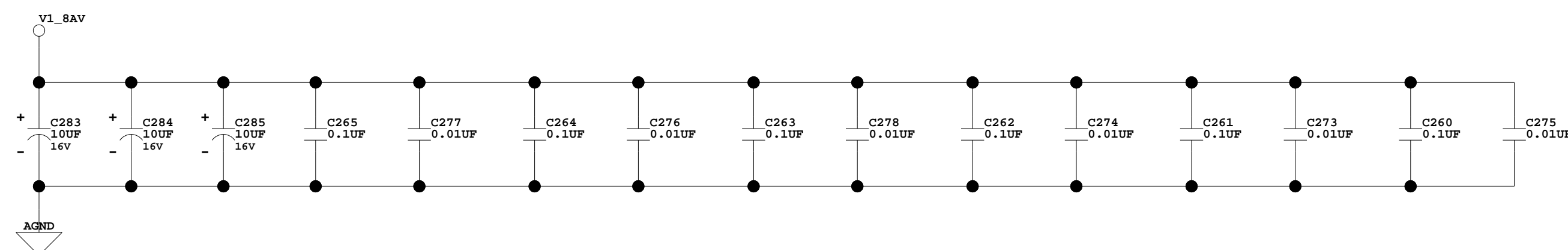
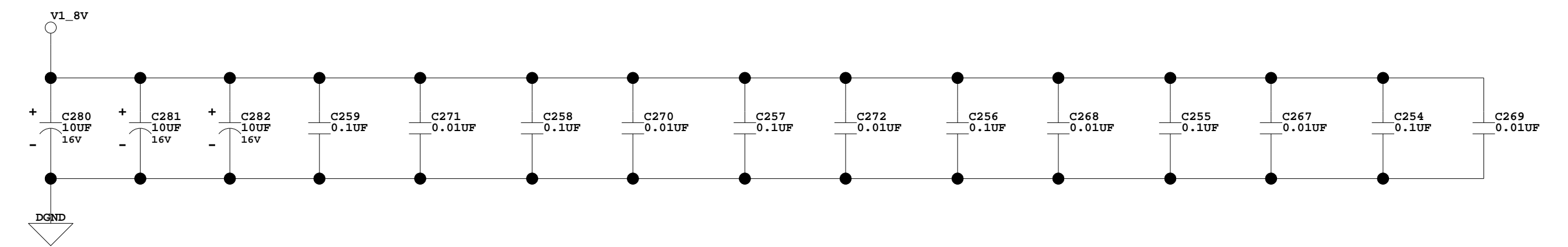
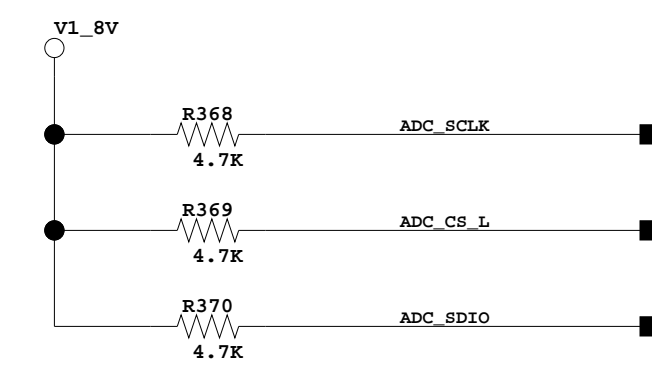
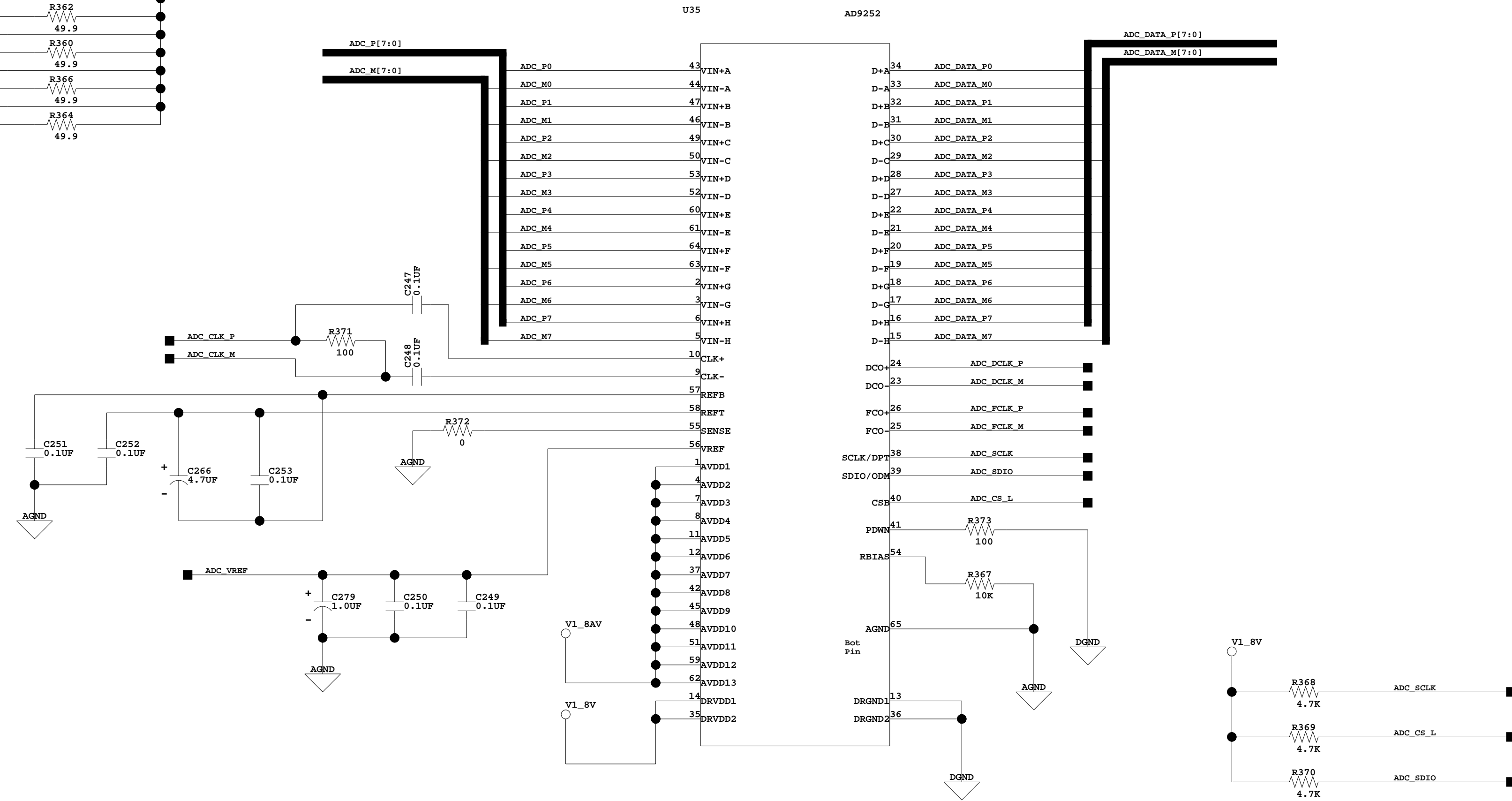
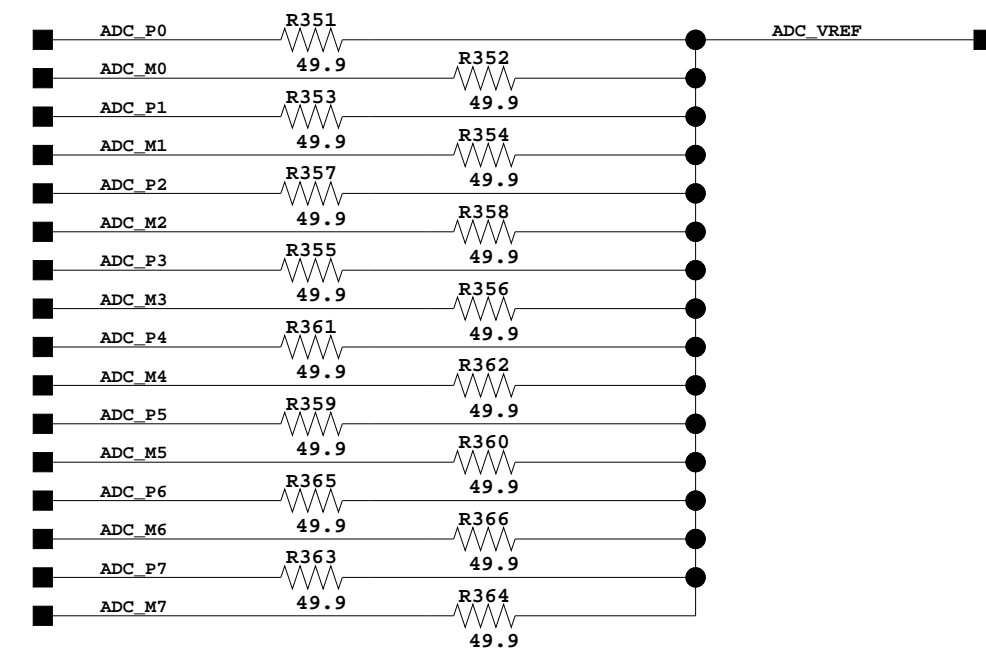

1-24-2011\_15:38

SLAC NATIONAL ACCELERATOR LABORATORY U.S. DEPARTMENT OF ENERGY		SHEET 10 OF 23
STANFORD UNIVERSITY STANFORD, CALIFORNIA		HEAVY P TRACKER READOUT RTM 8 CHANNEL ADC
PROPRIETARY DATA OF STANFORD UNIVERSITY AND/OR U.S. DEPARTMENT OF ENERGY. RECIPIENT SHALL NOT PUBLISH THE INFORMATION WITHIN UNLESS GRANTED SPECIFIC PERMISSION OF STANFORD UNIVERSITY.		
INGR Ryan Herbat	DATE 2010	APPROVALS
LOCATED AT SHEET 8		
SD-249-901-02-C01		

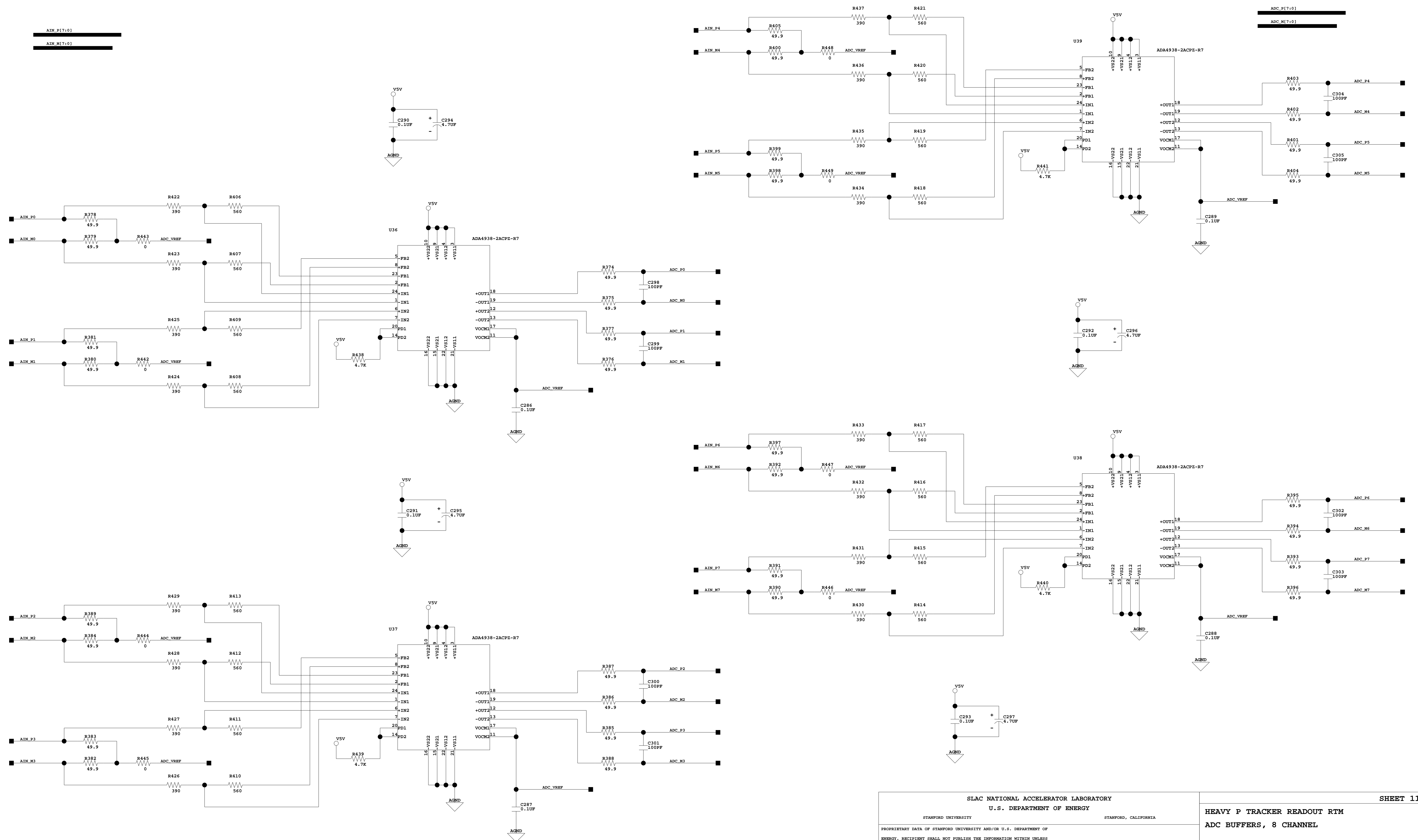

1-24-2011\_15:38

<b>SLAC NATIONAL ACCELERATOR LABORATORY</b> <b>U.S. DEPARTMENT OF ENERGY</b>		SHEET 11 OF 23
STANFORD UNIVERSITY STANFORD, CALIFORNIA		<b>HEAVY P TRACKER READOUT RTM</b> <b>ADC BUFFERS, 8 CHANNEL</b>
PROPRIETARY DATA OF STANFORD UNIVERSITY AND/OR U.S. DEPARTMENT OF ENERGY. RECIPIENT SHALL NOT PUBLISH THE INFORMATION WITHIN UNLESS GRANTED SPECIFIC PERMISSION OF STANFORD UNIVERSITY.		
INCR DFR CDR	Ryan Herbst 2010	APPROVALS
LOCATED AT SHEET 8		SD-249-901-02-C01

**ADC INPUT TERMINATION  
PLACE NEAR ADC**

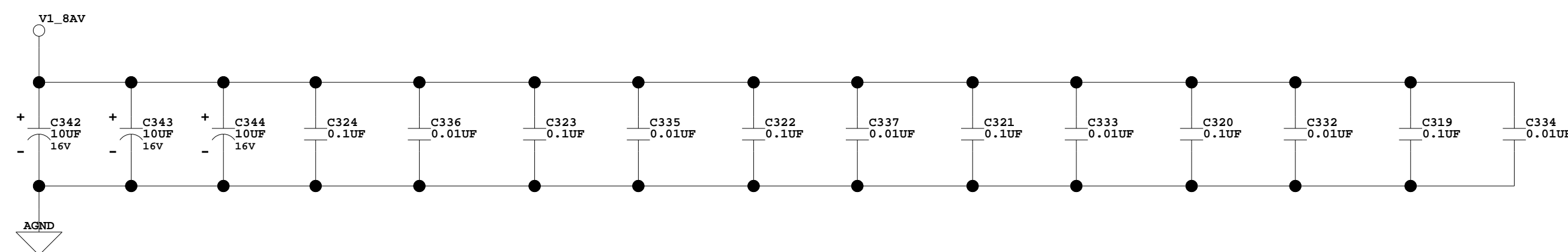
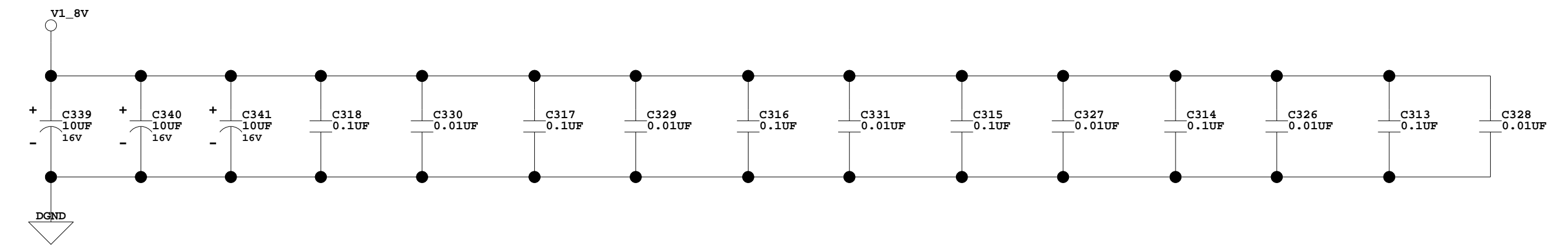
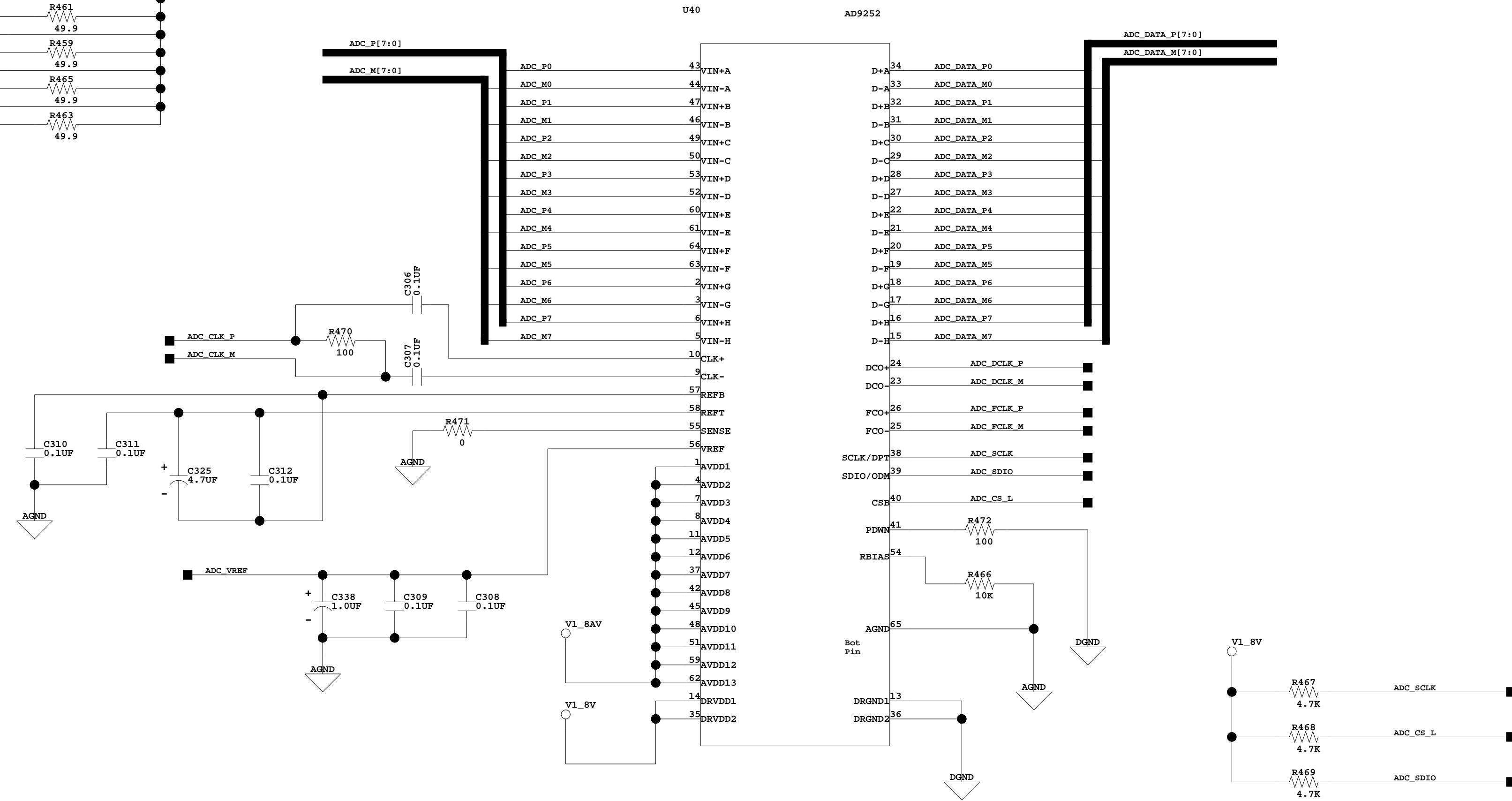
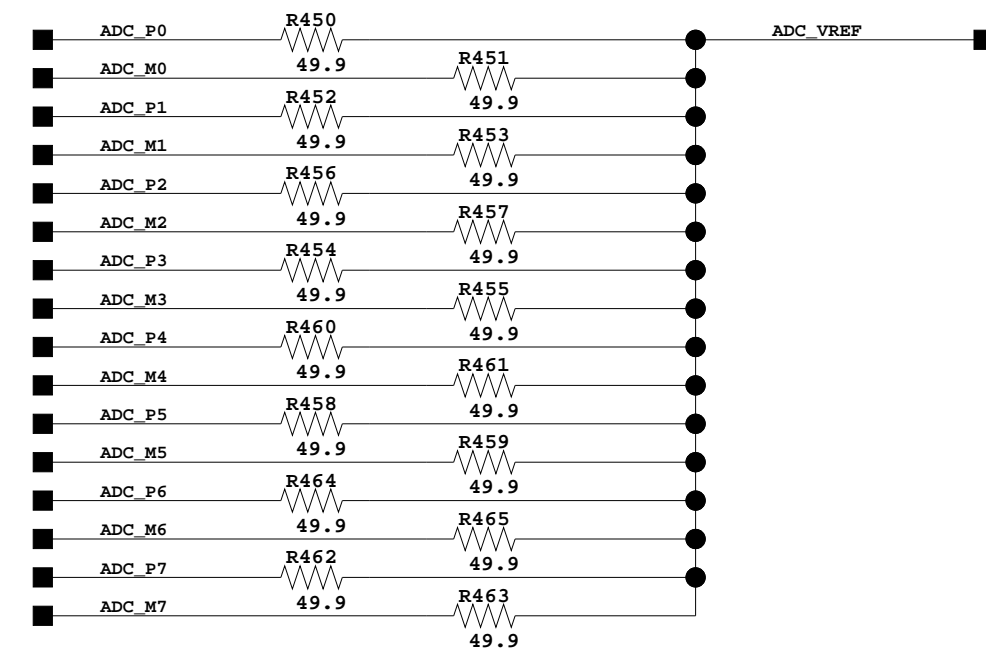

1-24-2011\_15:38

SLAC NATIONAL ACCELERATOR LABORATORY U.S. DEPARTMENT OF ENERGY		SHEET 12 OF 23
STANFORD UNIVERSITY STANFORD, CALIFORNIA		HEAVY P TRACKER READOUT RTM 8 CHANNEL ADC
PROPRIETARY DATA OF STANFORD UNIVERSITY AND/OR U.S. DEPARTMENT OF ENERGY. RECIPIENT SHALL NOT PUBLISH THE INFORMATION WITHIN UNLESS GRANTED SPECIFIC PERMISSION OF STANFORD UNIVERSITY.		
INGR Ryan Herbst	DATE 2010	APPROVALS
LOCATED AT SHEET 8 SD-249-901-02-C01		

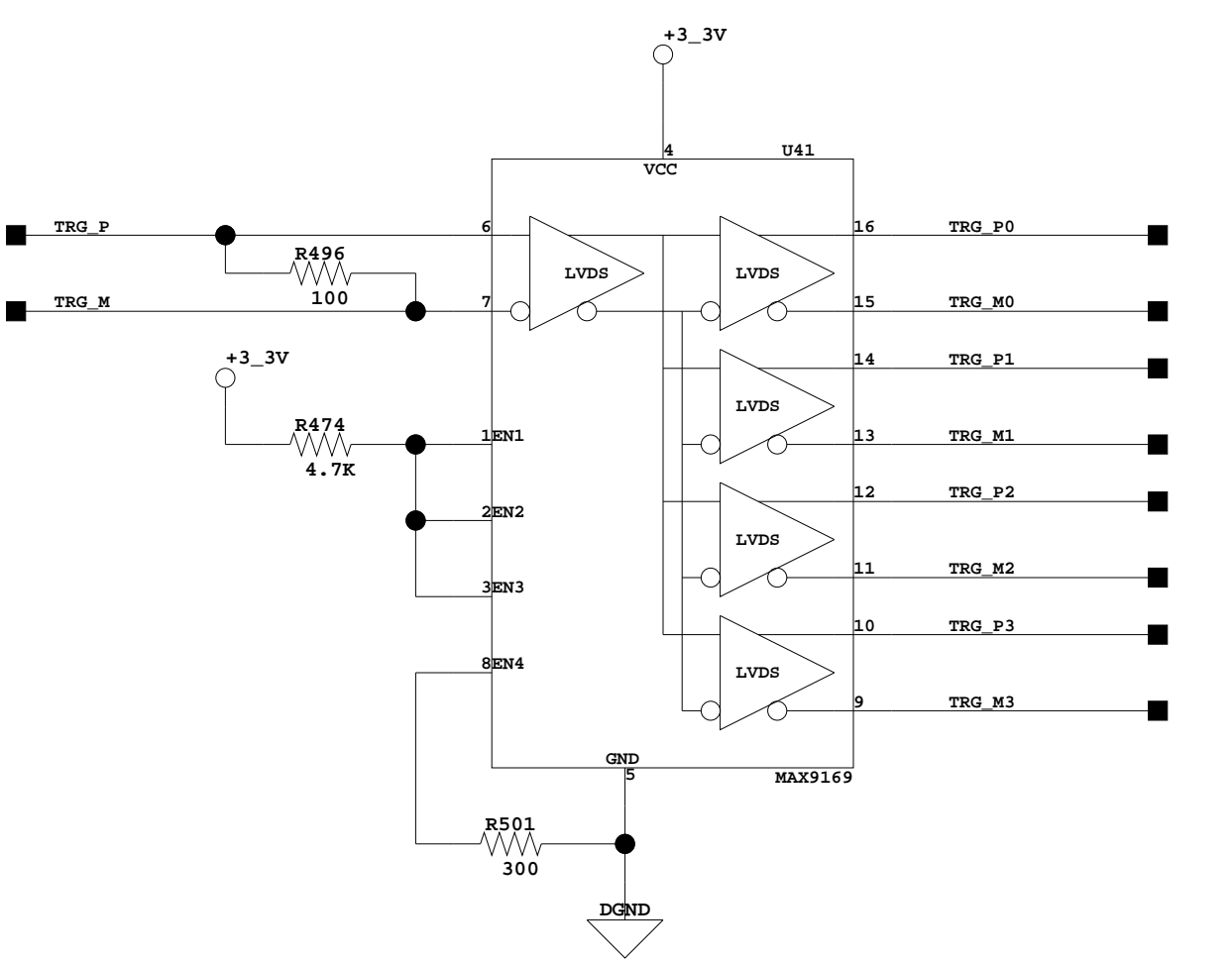
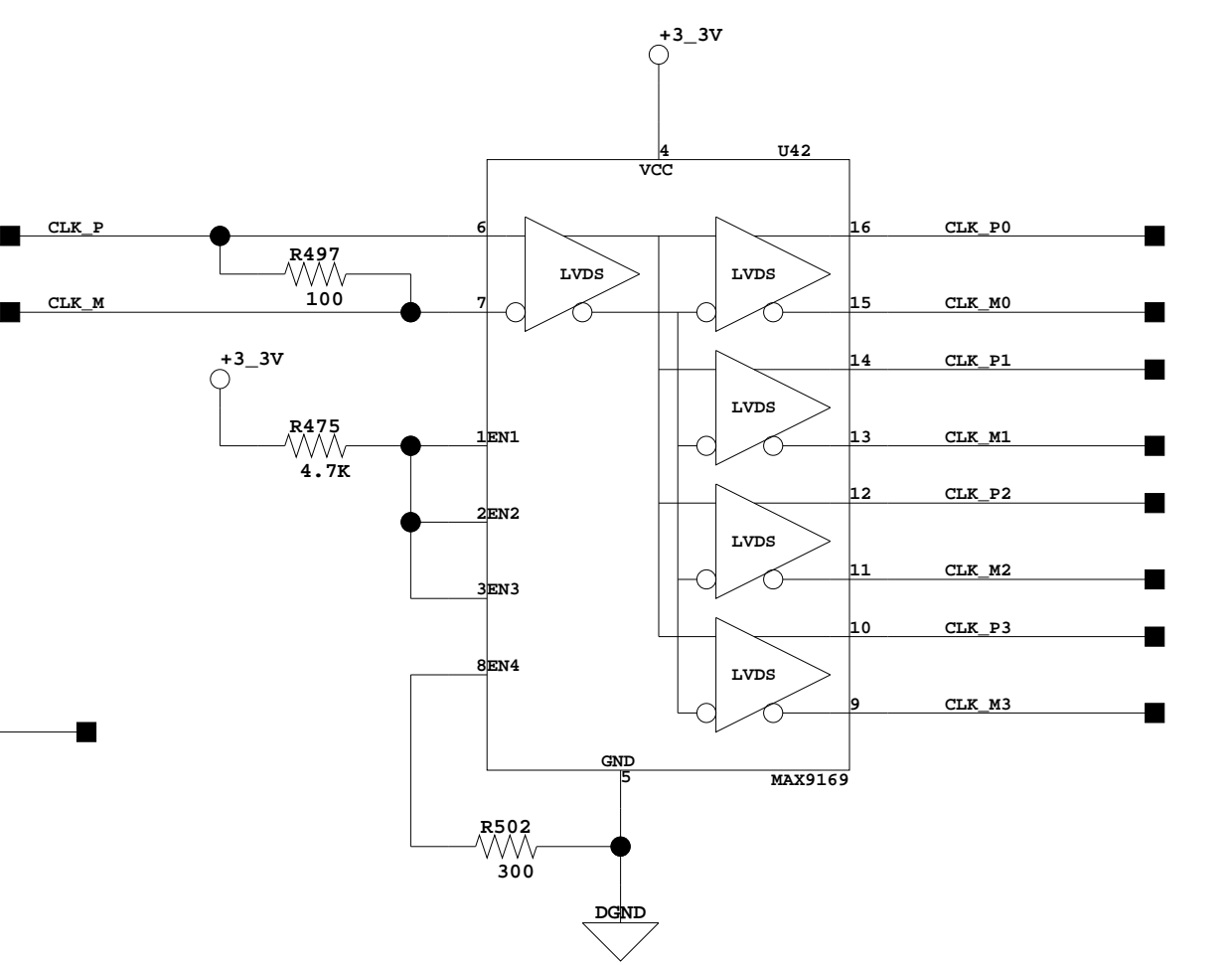
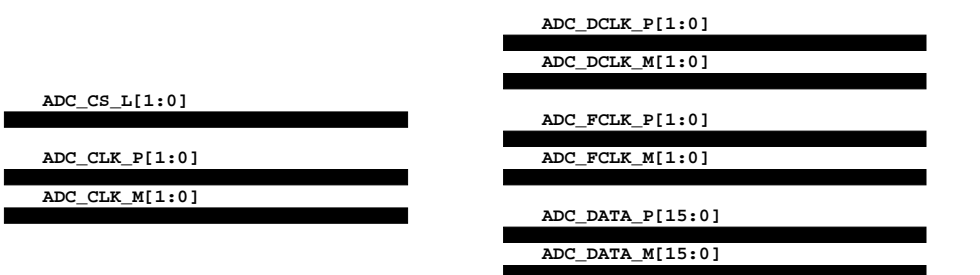
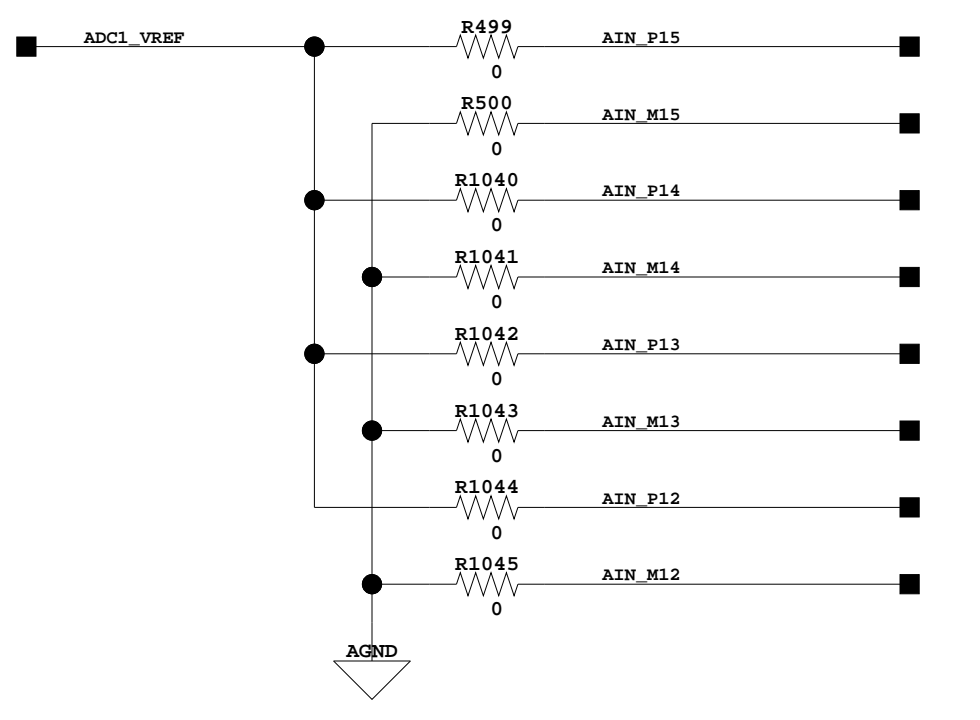
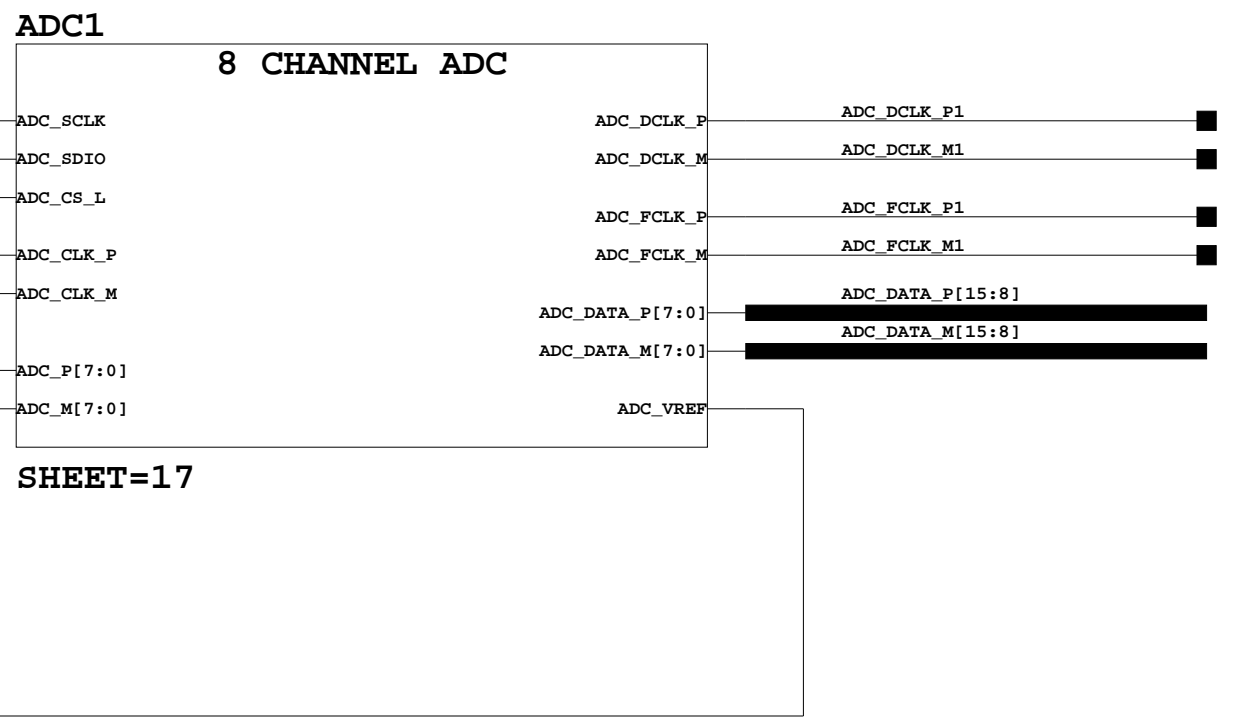
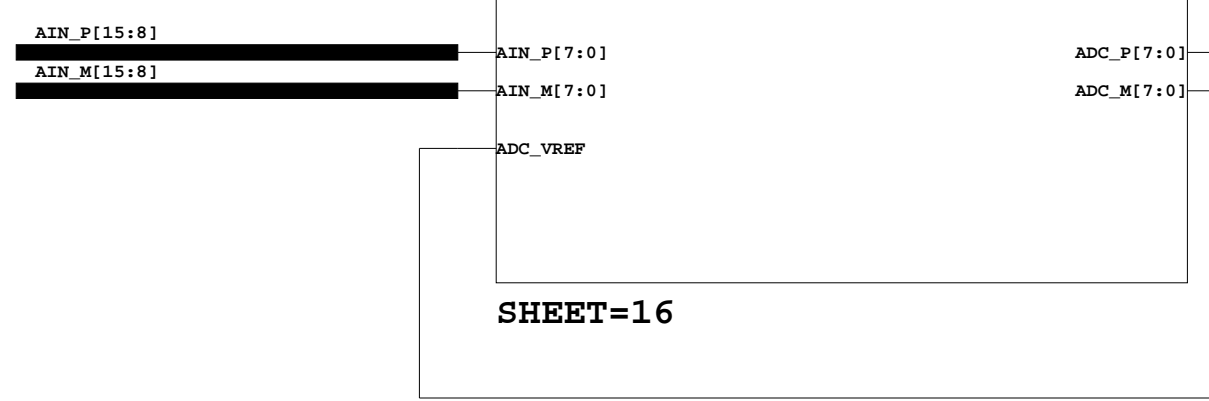
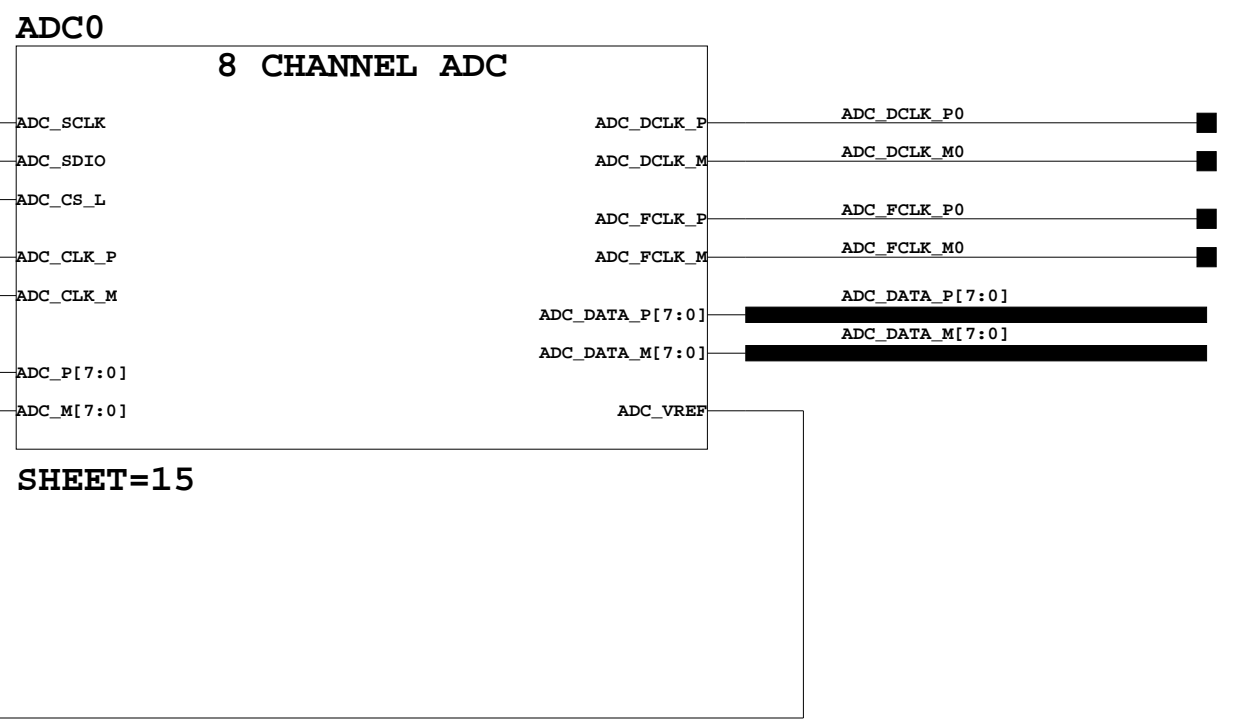
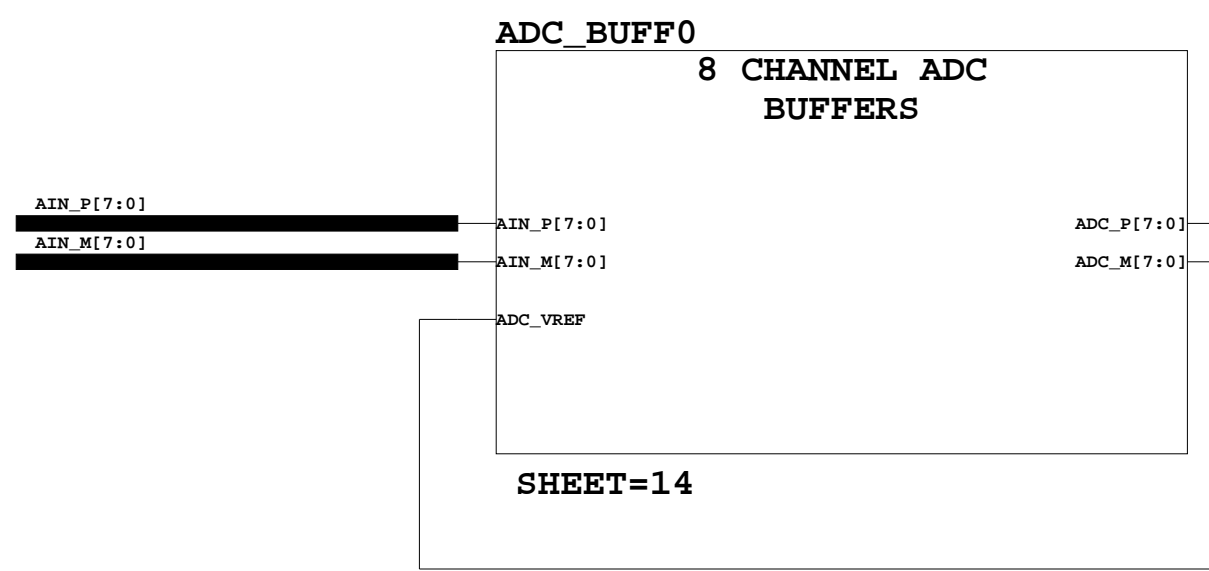
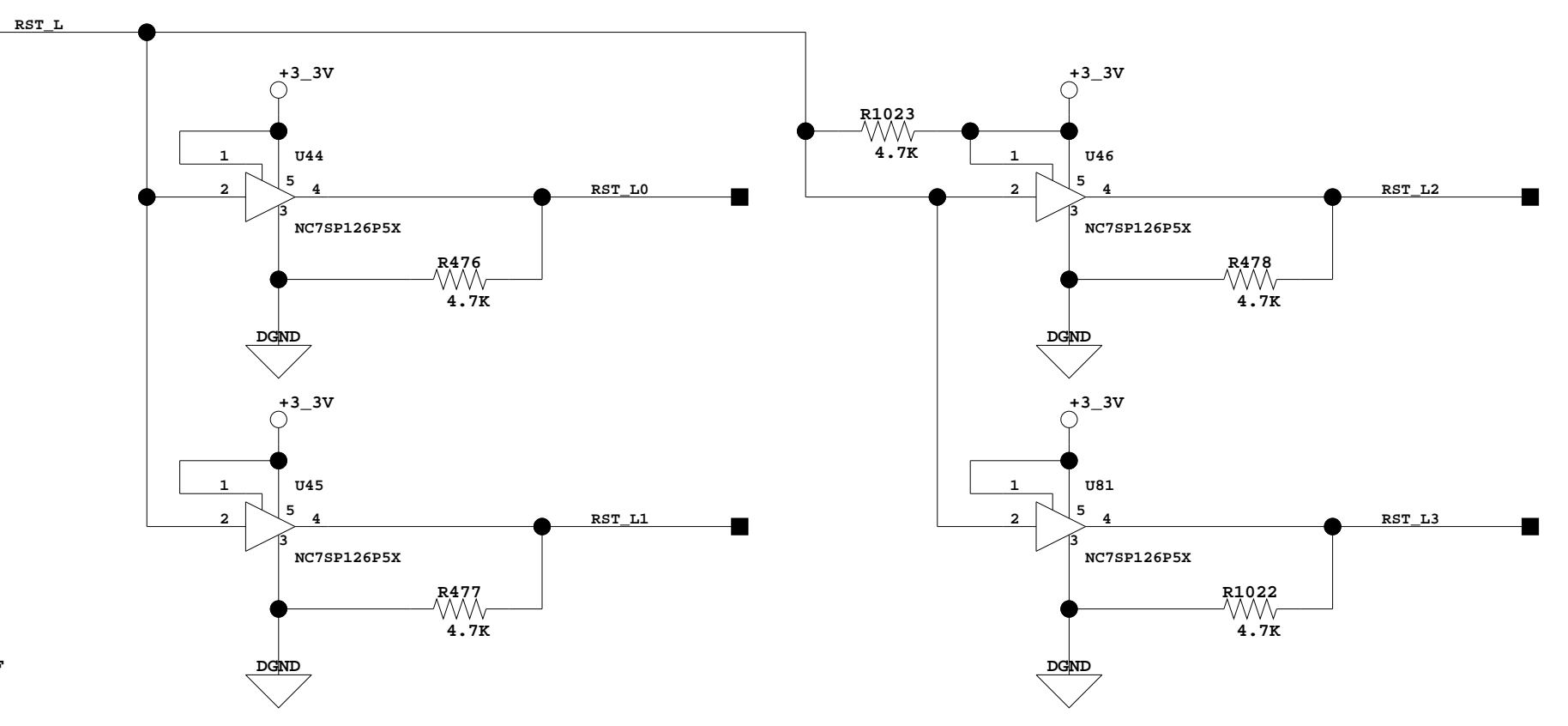
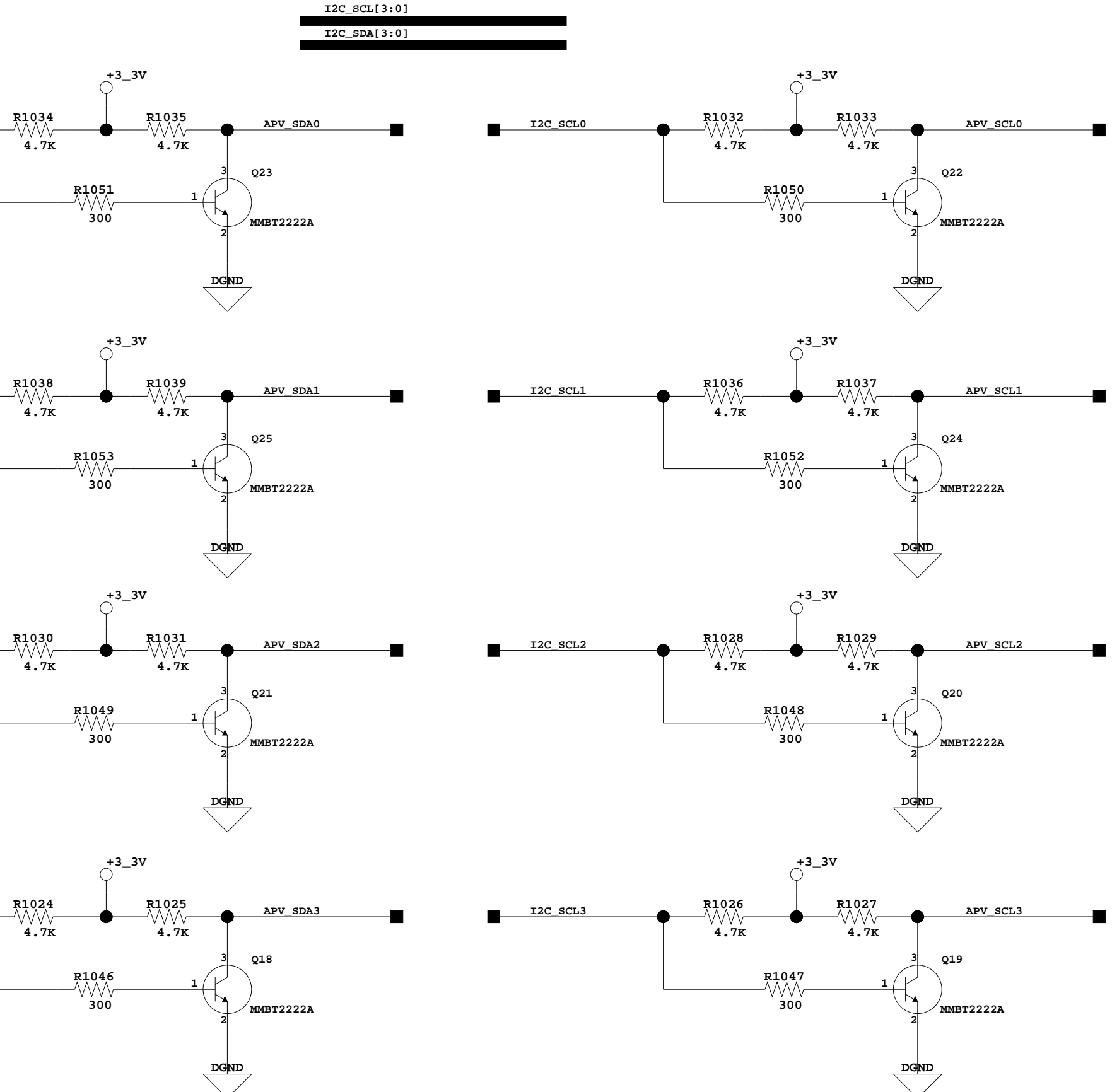
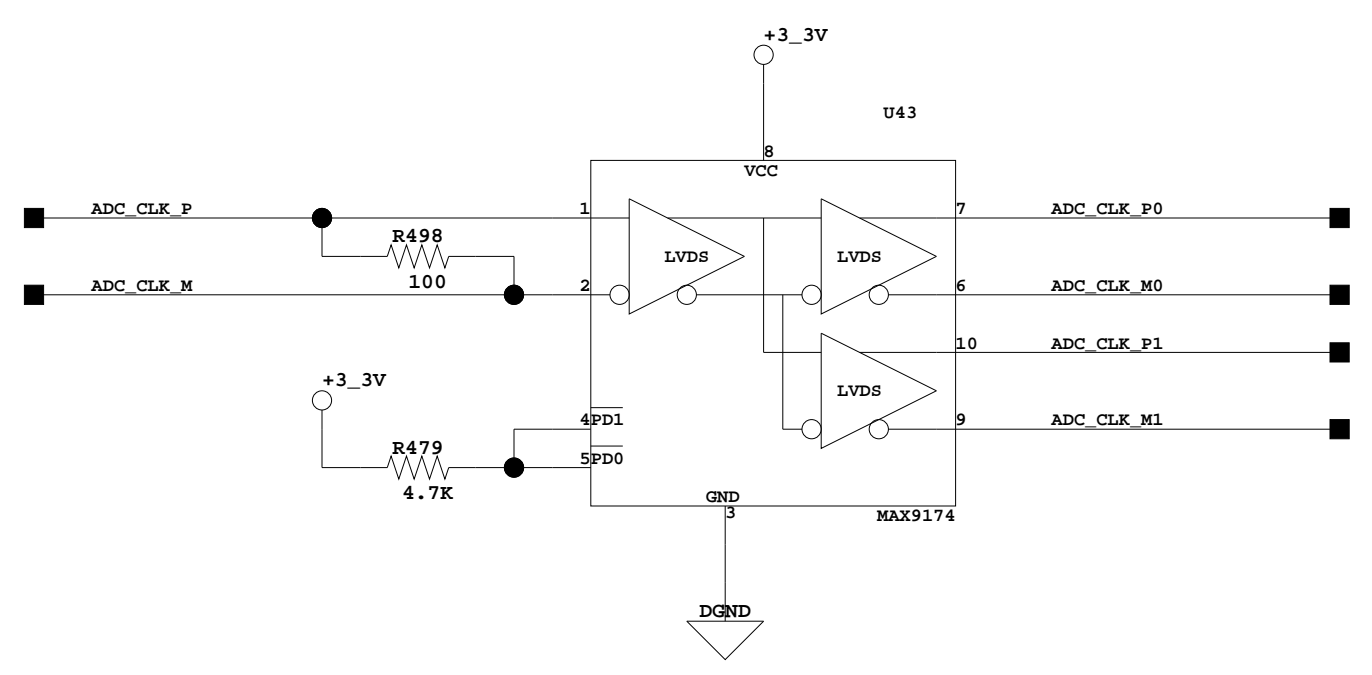
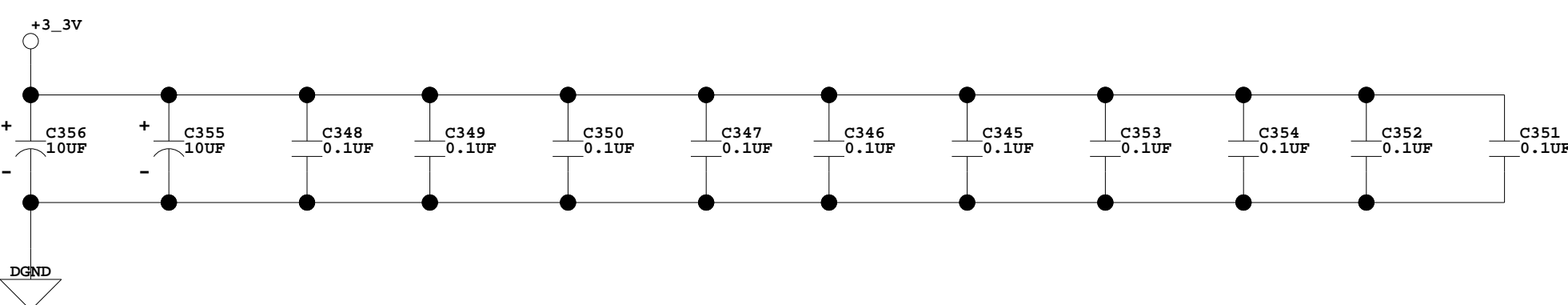
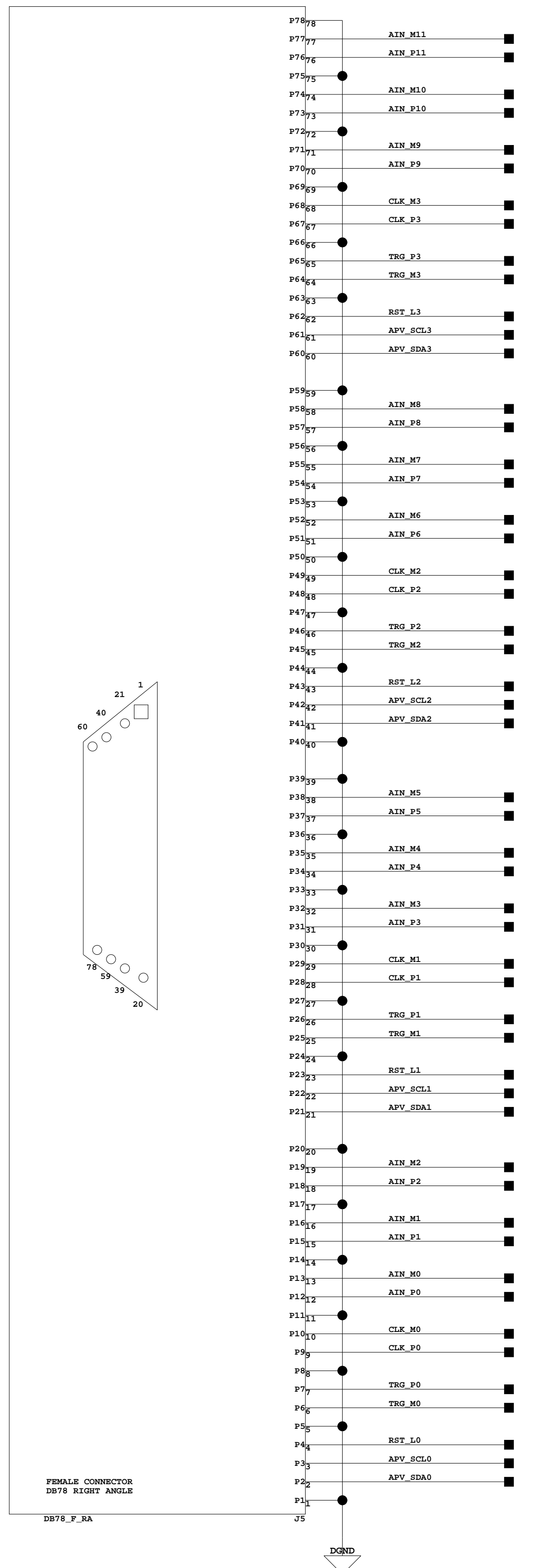

SLAC NATIONAL ACCELERATOR LABORATORY  
U.S. DEPARTMENT OF ENERGY

STANFORD UNIVERSITY STANFORD, CALIFORNIA

PROPRIETARY DATA OF STANFORD UNIVERSITY AND/OR U.S. DEPARTMENT OF ENERGY. RECIPIENT SHALL NOT PUBLISH THE INFORMATION WITHIN UNLESS GRANTED SPECIFIC PERMISSION OF STANFORD UNIVERSITY.

DATE	APPROVALS
2010	Ryan Herbst

SHEET 13 OF 23

HEAVY P TRACKER READOUT RTM  
APV25 CONNECTOR

LOCATED AT SHEET 1  
SD-249-901-02-C01

1-24-2011\_15:40

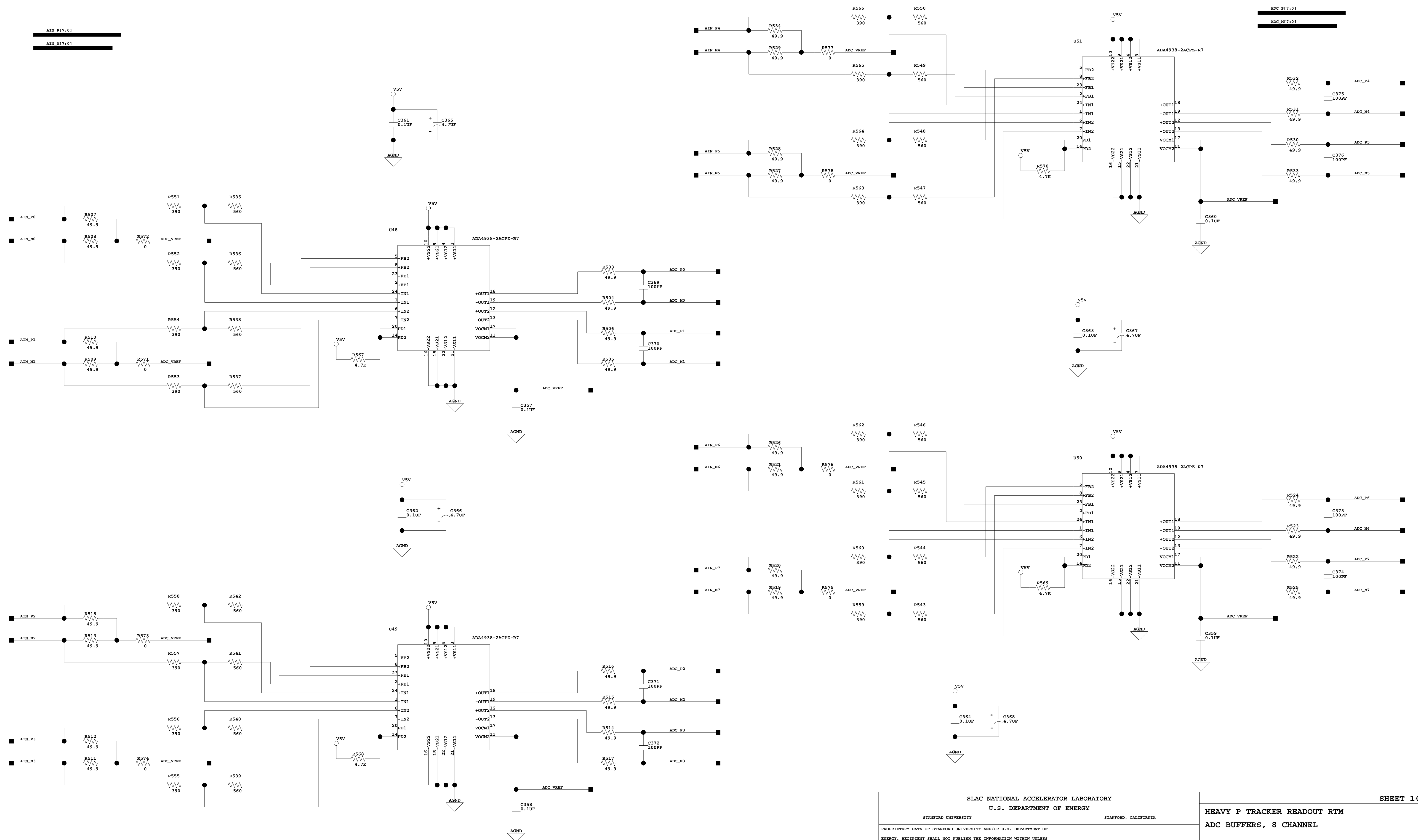

1-24-2011\_15:38

<b>SLAC NATIONAL ACCELERATOR LABORATORY</b> <b>U.S. DEPARTMENT OF ENERGY</b>		SHEET 14 OF 23
<small>STANFORD UNIVERSITY</small>		<b>HEAVY P TRACKER READOUT RTM</b> <b>ADC BUFFERS, 8 CHANNEL</b>
<small>PROPRIETARY DATA OF STANFORD UNIVERSITY AND/OR U.S. DEPARTMENT OF ENERGY. RECIPIENT SHALL NOT PUBLISH THE INFORMATION WITHIN UNLESS GRANTED SPECIFIC PERMISSION OF STANFORD UNIVERSITY.</small>		
<small>INDR</small>	<small>DATE</small>	<small>APPROVALS</small>
Ryan Herbat	2010	
<small>DFR</small>		
<small>CDR</small>		
LOCATED AT SHEET 13		
SD-249-901-02-C01		

**ADC INPUT TERMINATION**  
PLACE NEAR ADC

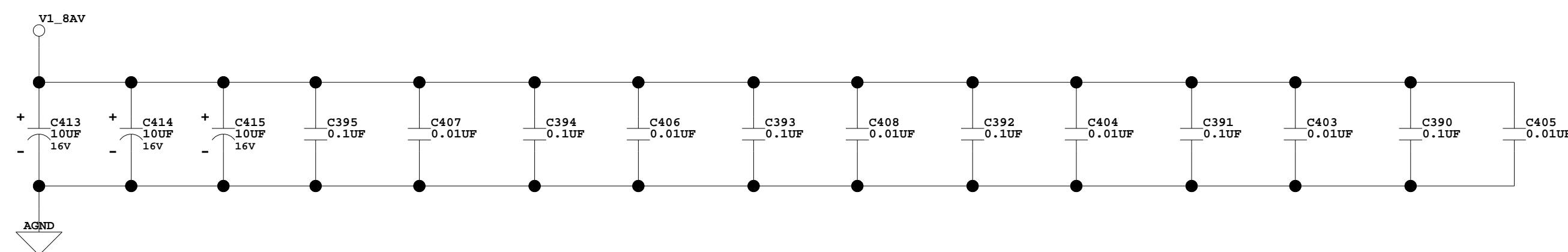
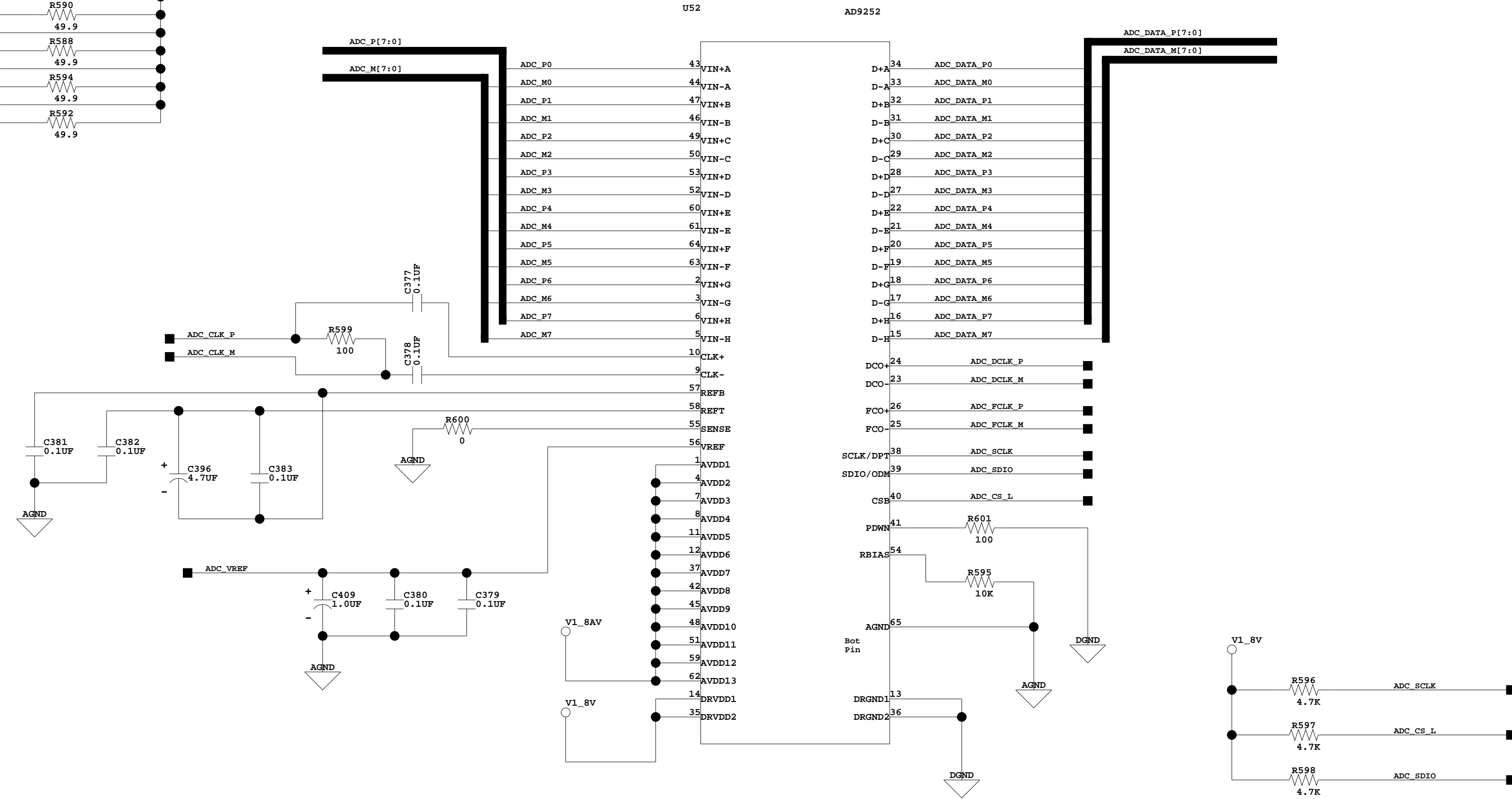
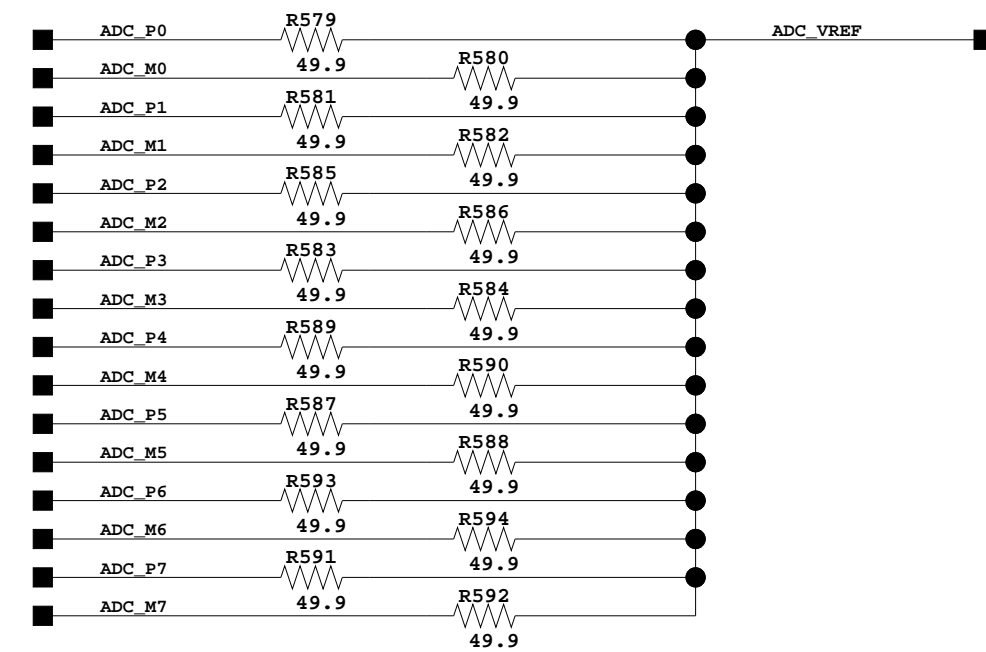

1-24-2011\_15:38

SLAC NATIONAL ACCELERATOR LABORATORY U.S. DEPARTMENT OF ENERGY		SHEET 15 OF 23
STANFORD UNIVERSITY STANFORD, CALIFORNIA		HEAVY P TRACKER READOUT RTM 8 CHANNEL ADC
PROPRIETARY DATA OF STANFORD UNIVERSITY AND/OR U.S. DEPARTMENT OF ENERGY. RECIPIENT SHALL NOT PUBLISH THE INFORMATION WITHIN UNLESS GRANTED SPECIFIC PERMISSION OF STANFORD UNIVERSITY.		
INGR Ryan Herbst	DATE 2010	APPROVALS
LOCATED AT SHEET 13		
SD-249-901-02-C01		

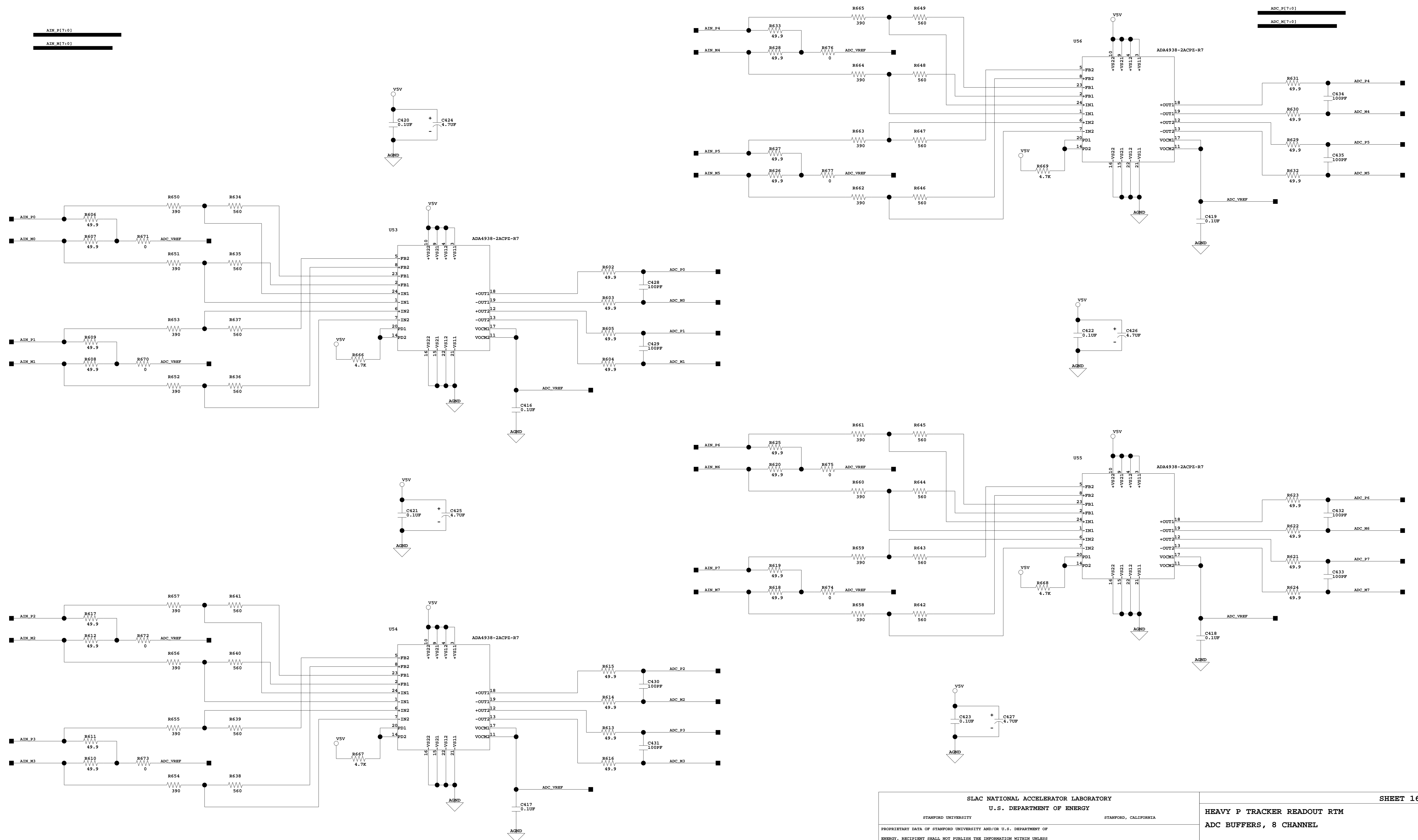

1-24-2011\_15:38

SLAC NATIONAL ACCELERATOR LABORATORY U.S. DEPARTMENT OF ENERGY		STANFORD, CALIFORNIA	
PROPRIETARY DATA OF STANFORD UNIVERSITY AND/OR U.S. DEPARTMENT OF ENERGY. RECIPIENT SHALL NOT PUBLISH THE INFORMATION WITHIN UNLESS GRANTED SPECIFIC PERMISSION OF STANFORD UNIVERSITY.		APPROVALS	
INDR Ryan Herbst	DATE 2010	APPROVALS	
DFR	DATE	APPROVALS	
CDR	DATE	APPROVALS	

SHEET 16 OF 23

**HEAVY P TRACKER READOUT RTM  
ADC BUFFERS, 8 CHANNEL**

LOCATED AT SHEET 13

SD-249-901-02-C01



ADC INPUT TERMINATION  
PLACE NEAR ADC

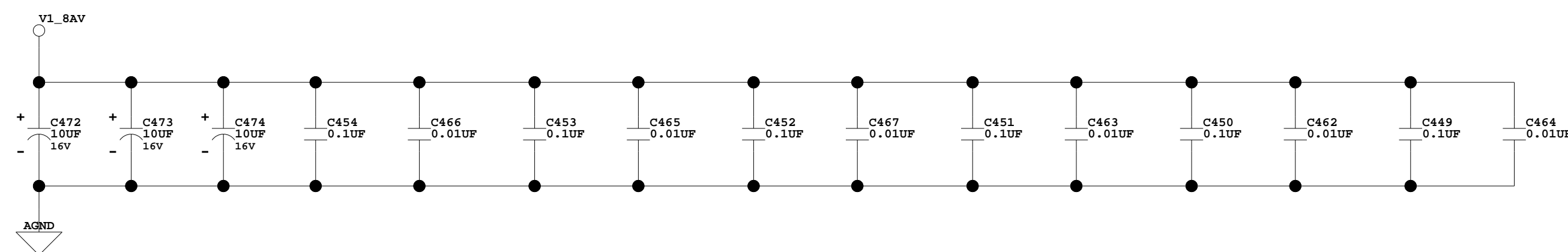
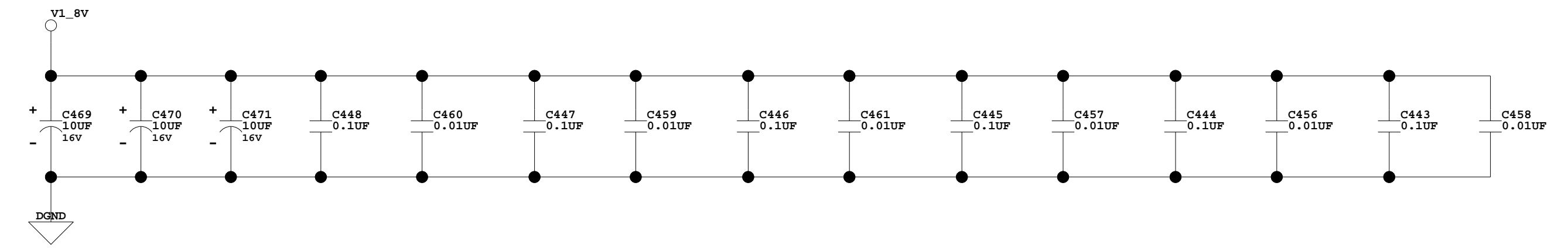
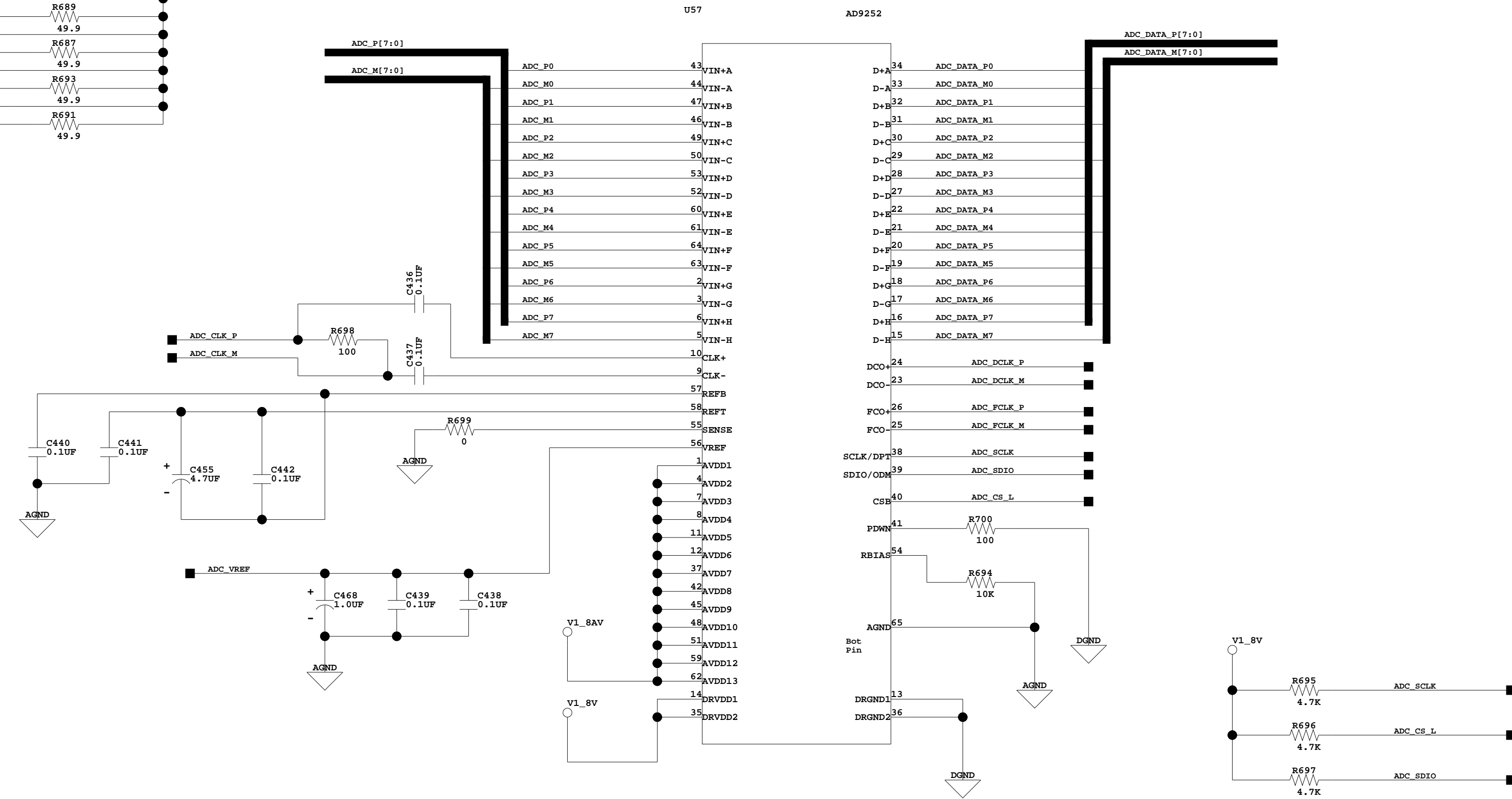
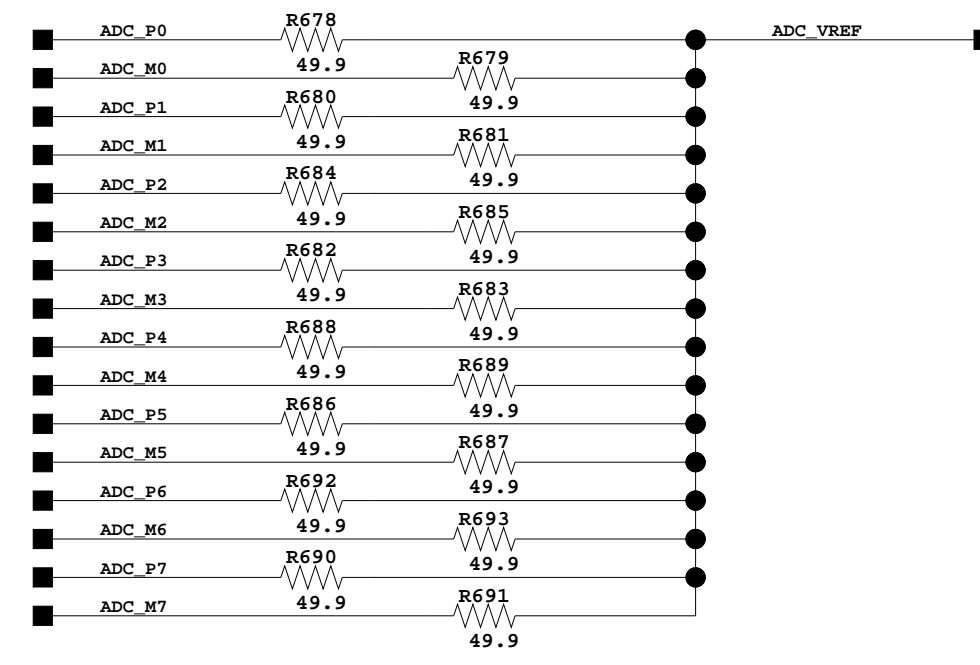

1-24-2011\_15:38

SLAC NATIONAL ACCELERATOR LABORATORY U.S. DEPARTMENT OF ENERGY		SHEET 17 OF 23
STANFORD UNIVERSITY STANFORD, CALIFORNIA		HEAVY P TRACKER READOUT RTM 8 CHANNEL ADC
PROPRIETARY DATA OF STANFORD UNIVERSITY AND/OR U.S. DEPARTMENT OF ENERGY. RECIPIENT SHALL NOT PUBLISH THE INFORMATION WITHIN UNLESS GRANTED SPECIFIC PERMISSION OF STANFORD UNIVERSITY.		
INGR	Ryan Herbst	DATE
DPTH		APPROVALS
CDRS		LOCATED AT SHEET 13
		SD-249-901-02-C01

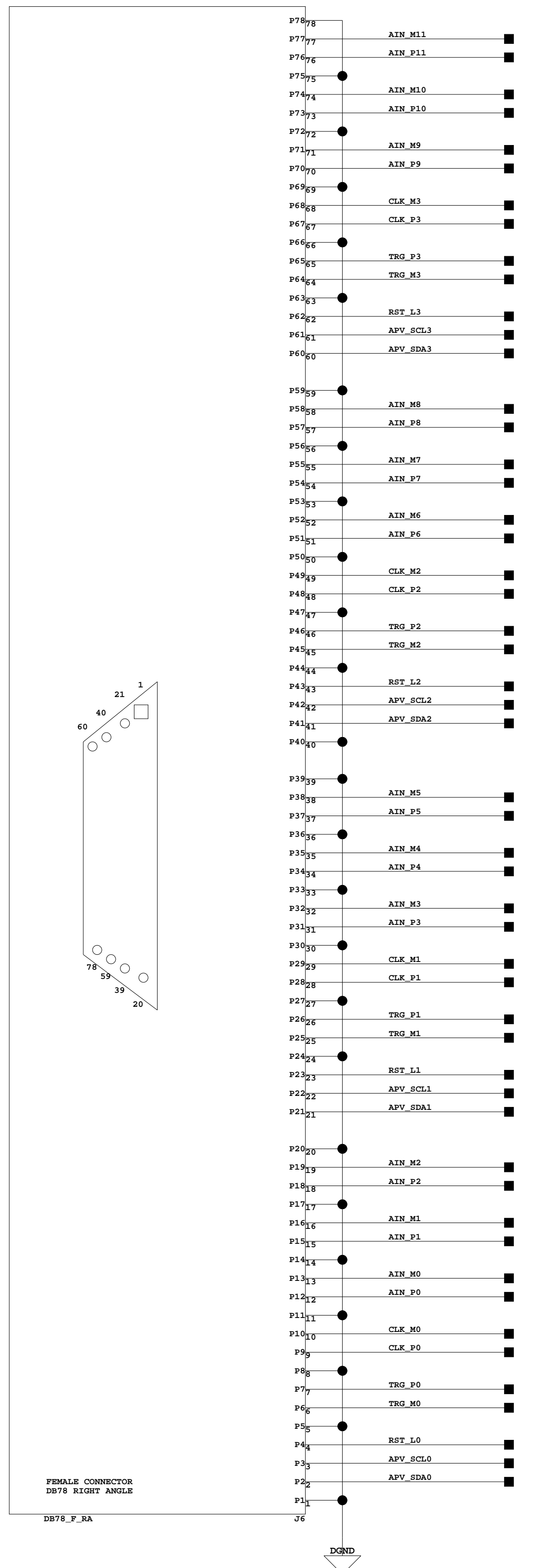

FEMALE CONNECTOR DB78 RIGHT ANGLE DB78\_F\_RA

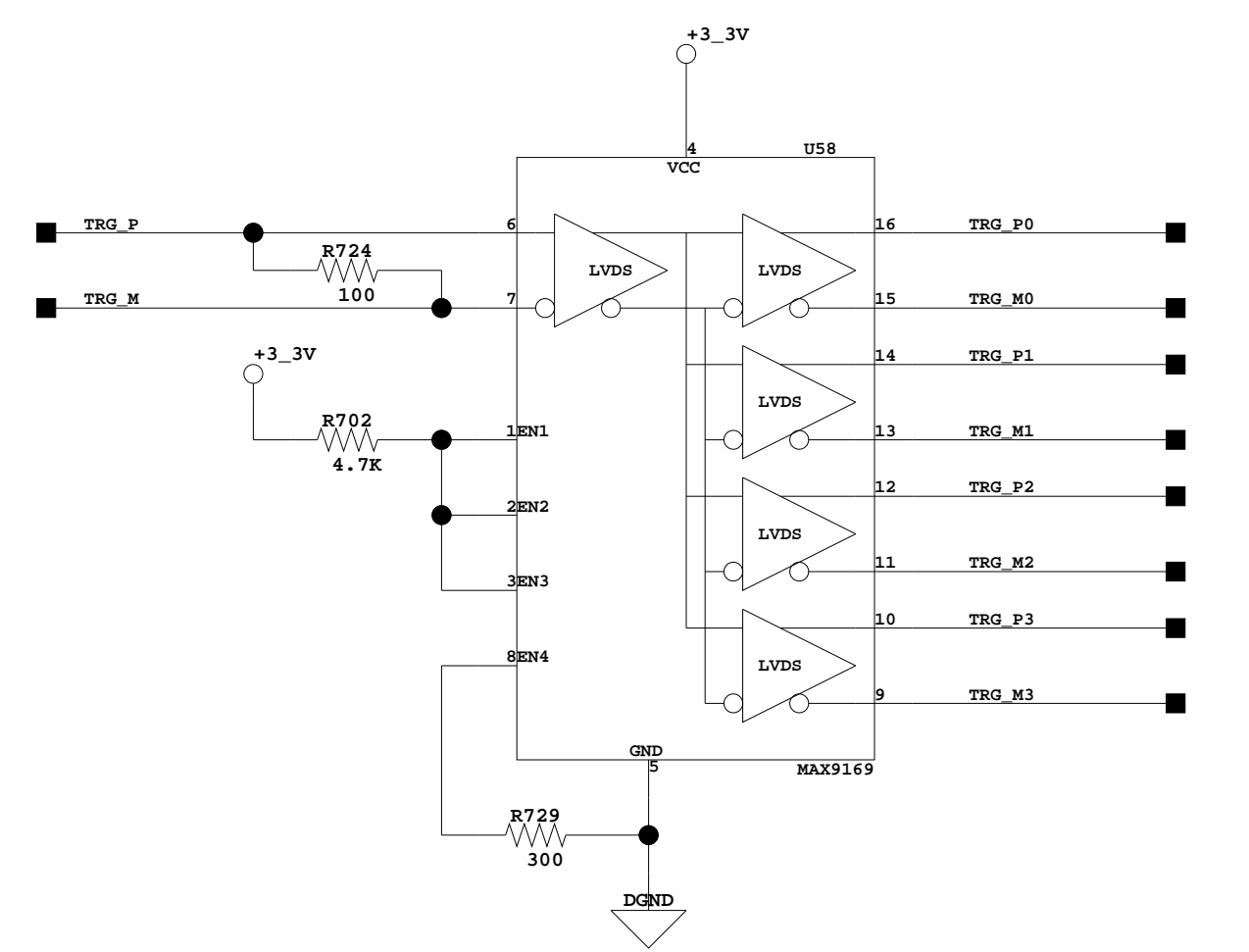
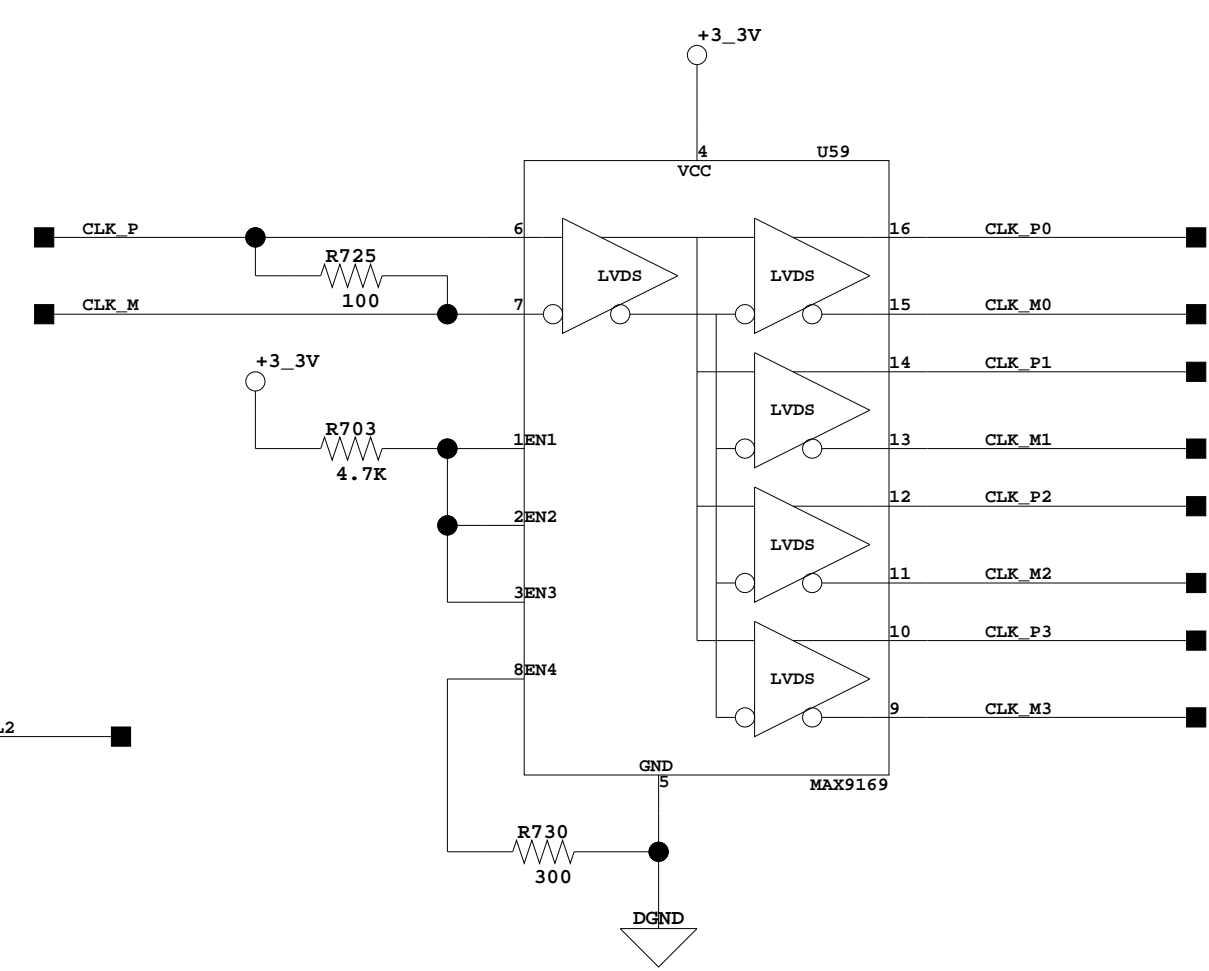
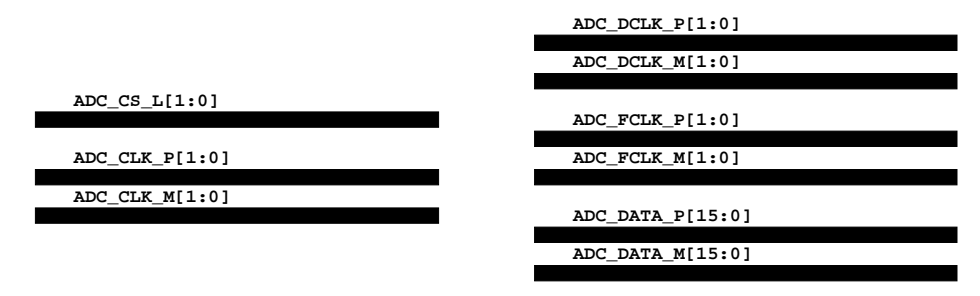
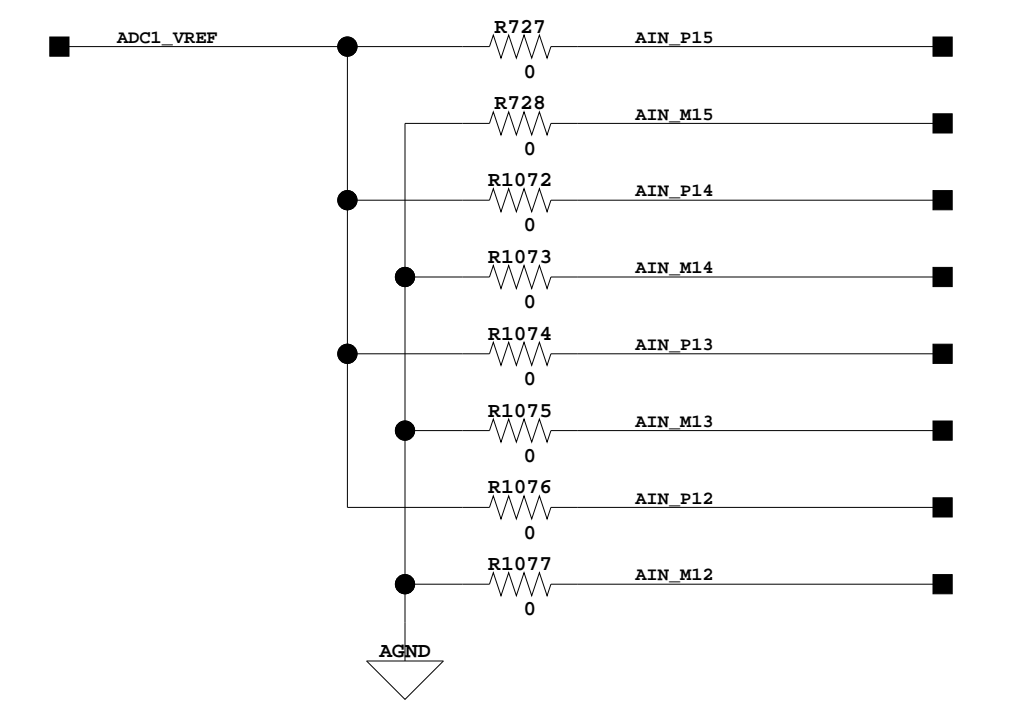
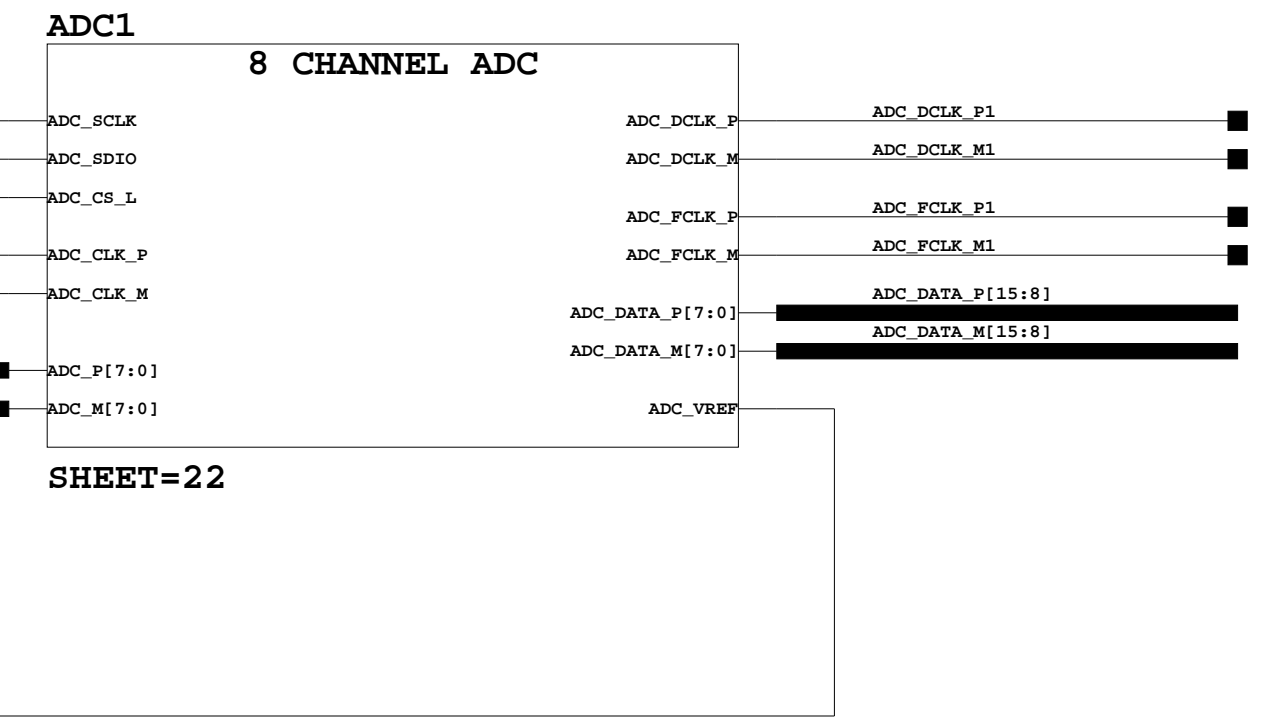
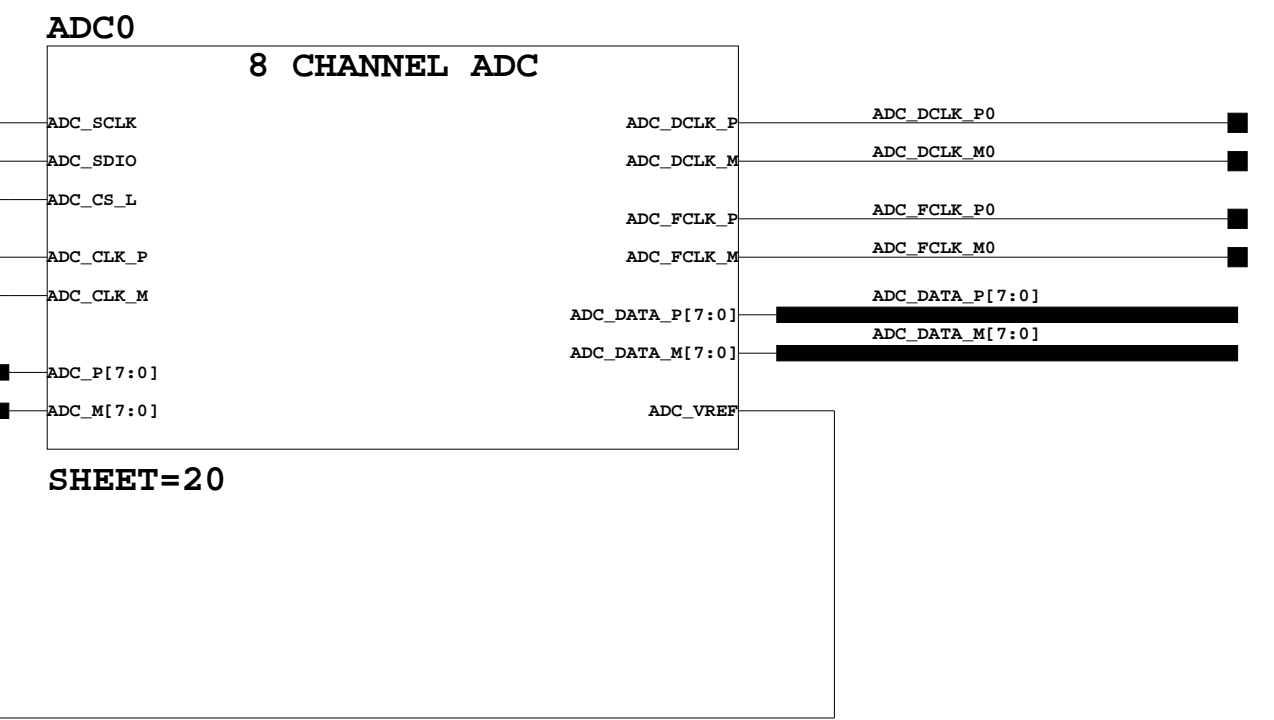
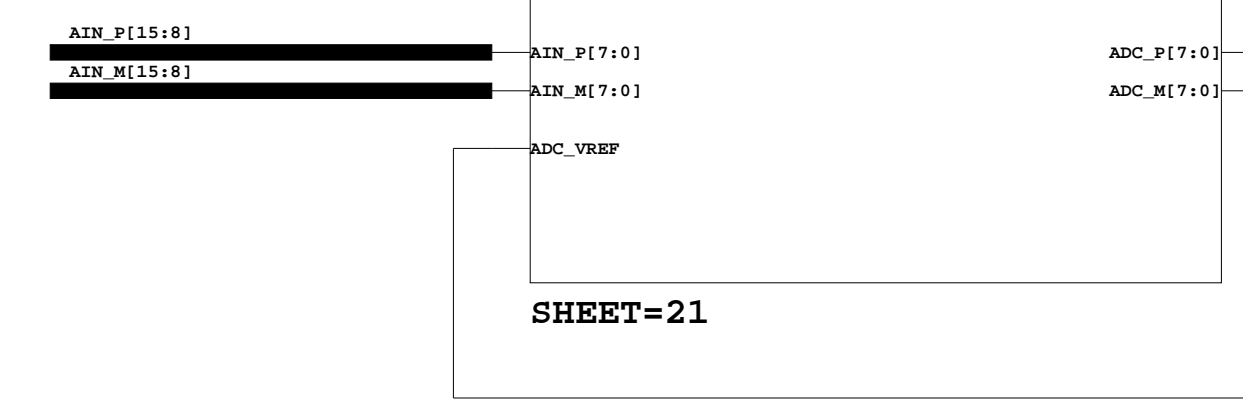
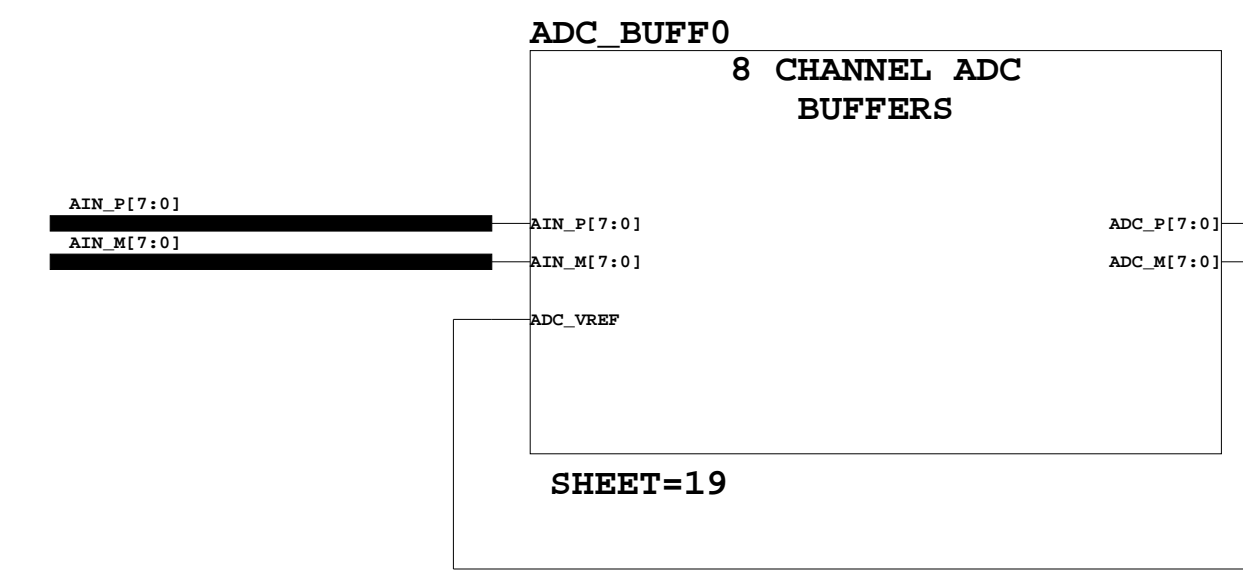
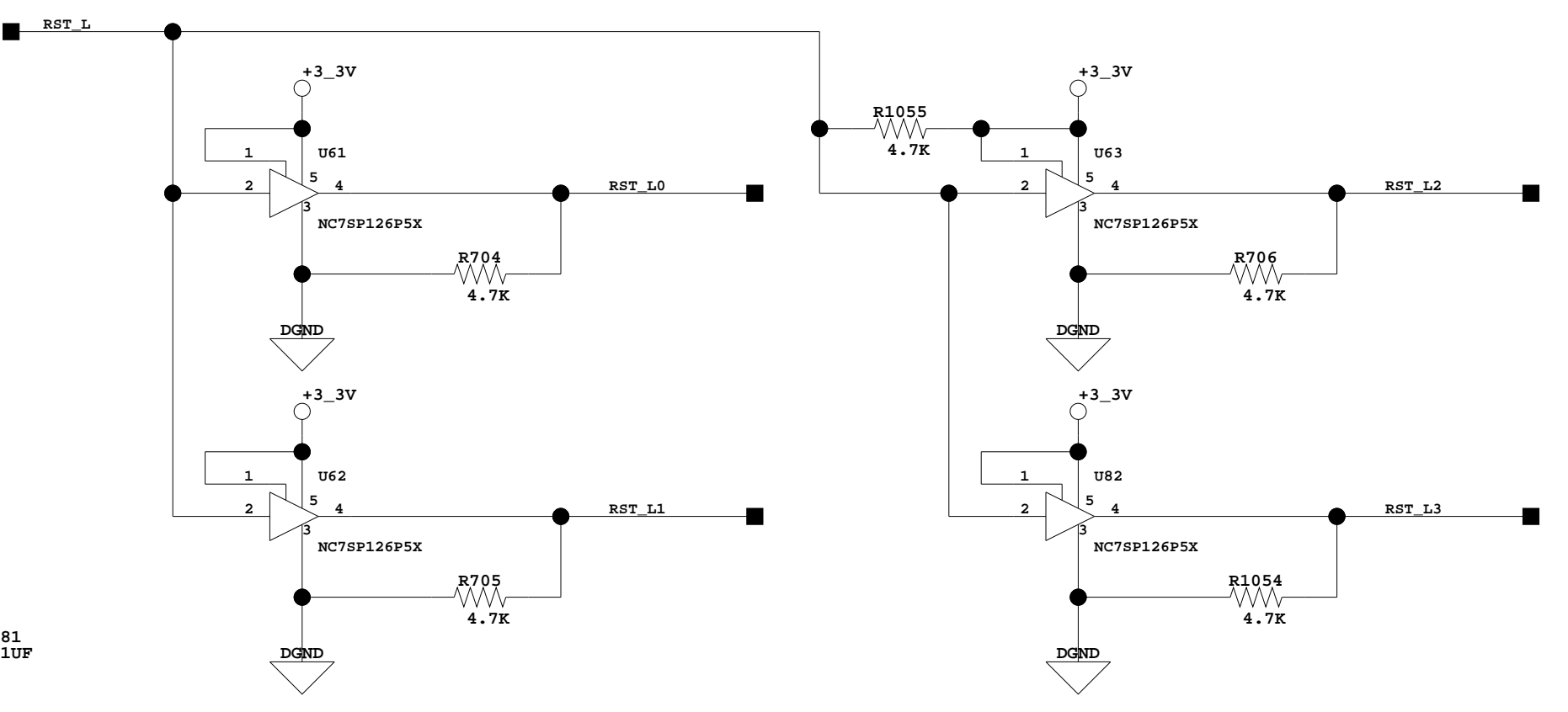
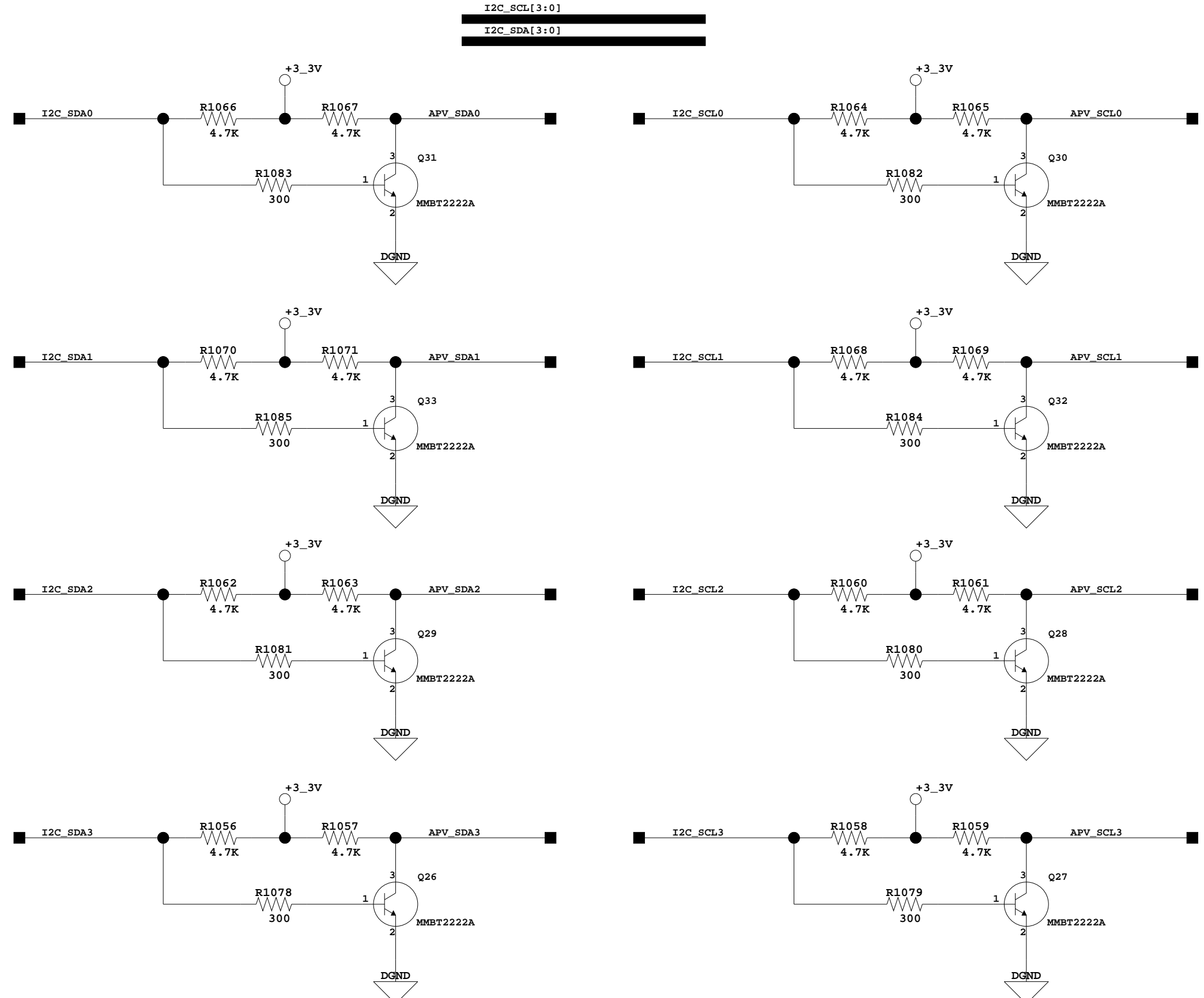
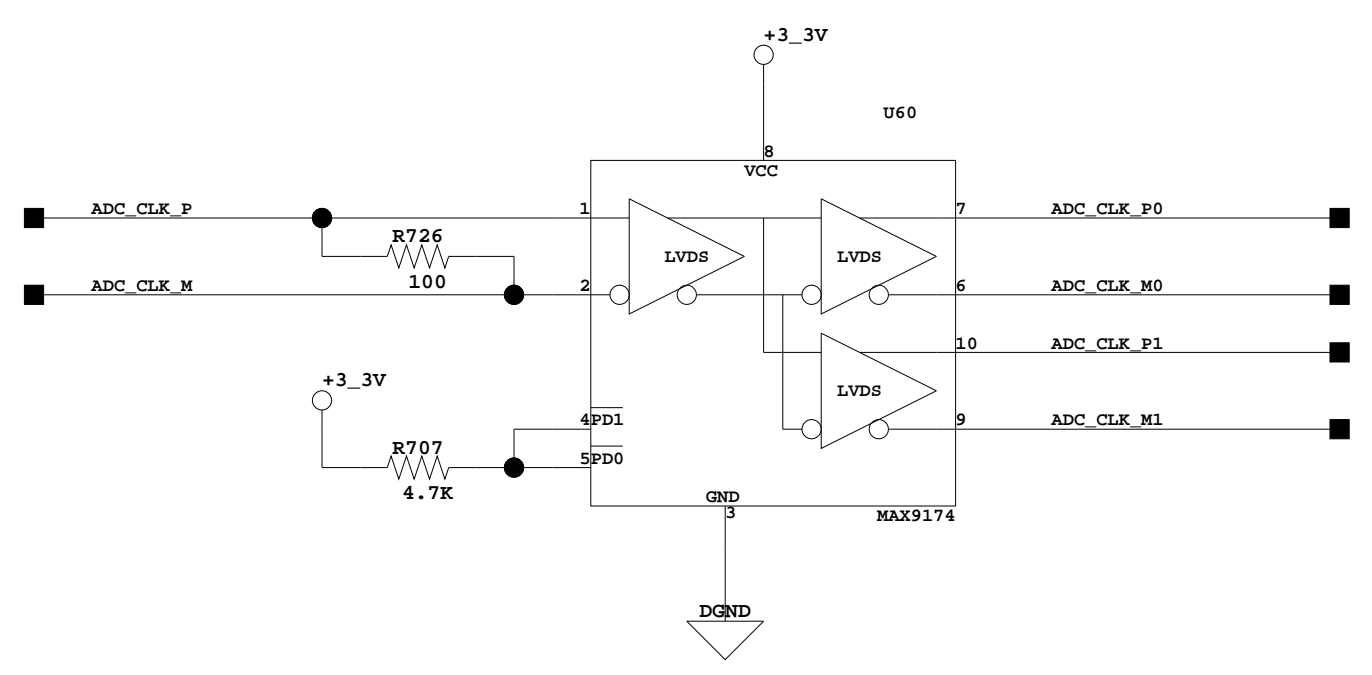
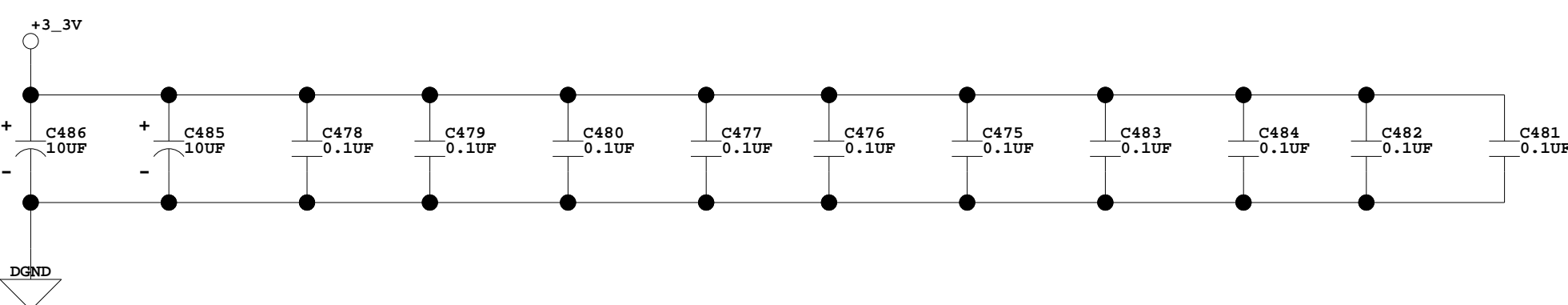

SLAC NATIONAL ACCELERATOR LABORATORY  
U.S. DEPARTMENT OF ENERGY

STANFORD UNIVERSITY STANFORD, CALIFORNIA

PROPRIETARY DATA OF STANFORD UNIVERSITY AND/OR U.S. DEPARTMENT OF ENERGY. RECIPIENT SHALL NOT PUBLISH THE INFORMATION WITHIN UNLESS GRANTED SPECIFIC PERMISSION OF STANFORD UNIVERSITY.

DATE	APPROVALS
2010	Ryan Herbst

SHEET 18 OF 23

HEAVY P TRACKER READOUT RTM  
APV25 CONNECTOR

LOCATED AT SHEET 1  
SD-249-901-02-C01

1-24-2011\_15:40

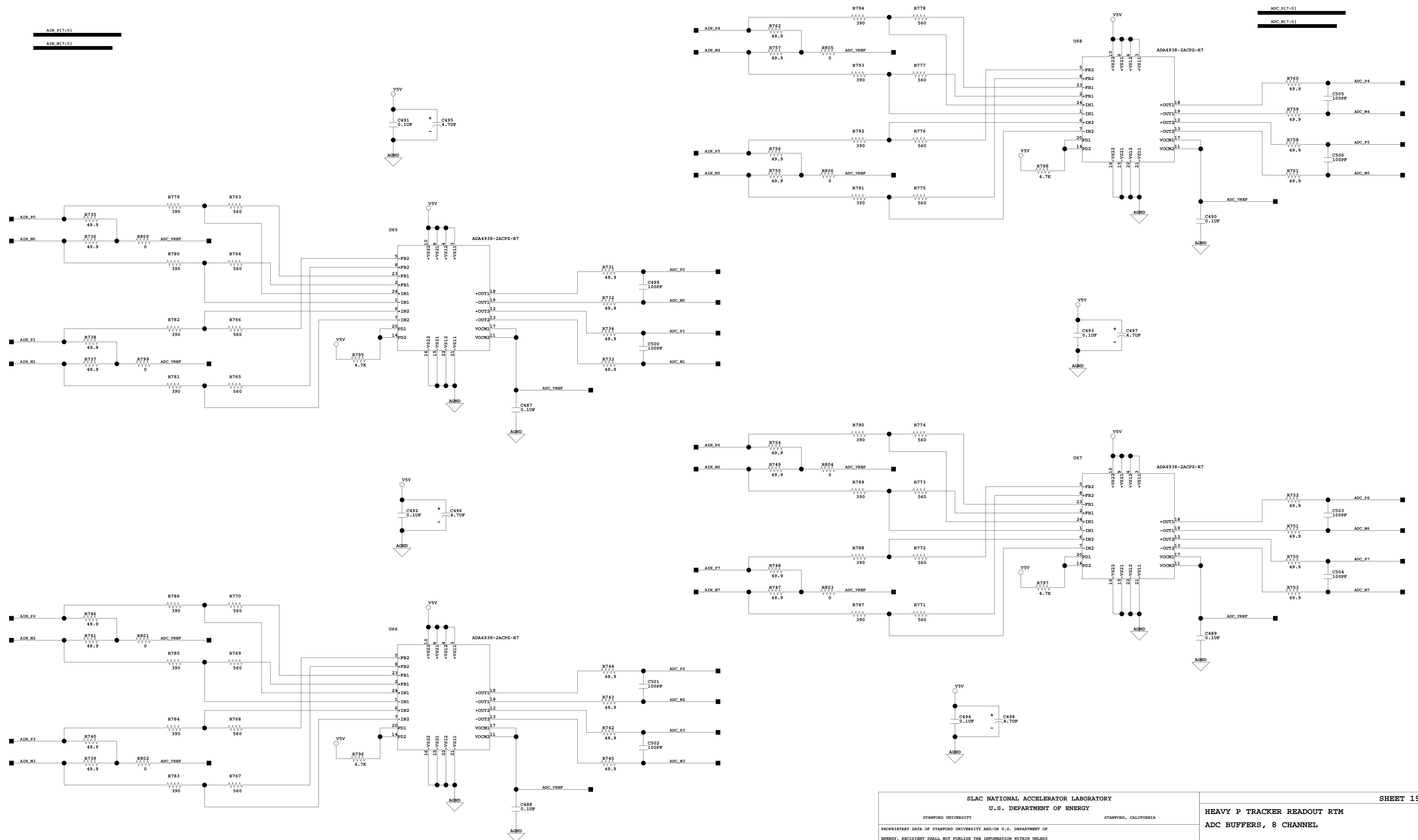

1-24-2011\_15:38

SLAC NATIONAL ACCELERATOR LABORATORY U.S. DEPARTMENT OF ENERGY		
STANFORD UNIVERSITY	STANFORD, CALIFORNIA	
PROPRIETARY DATA OF STANFORD UNIVERSITY AND/OR U.S. DEPARTMENT OF ENERGY. RECIPIENT SHALL NOT PUBLISH THE INFORMATION WITHIN UNLESS GRANTED SPECIFIC PERMISSION OF STANFORD UNIVERSITY.		
INDR	DATE	APPROVALS
DFR	2010	
CDR		

SHEET 19 OF 23

**HEAVY P TRACKER READOUT RTM**  
**ADC BUFFERS, 8 CHANNEL**

LOCATED AT SHEET 18

SD-249-901-02-C01

ADC INPUT TERMINATION  
PLACE NEAR ADC

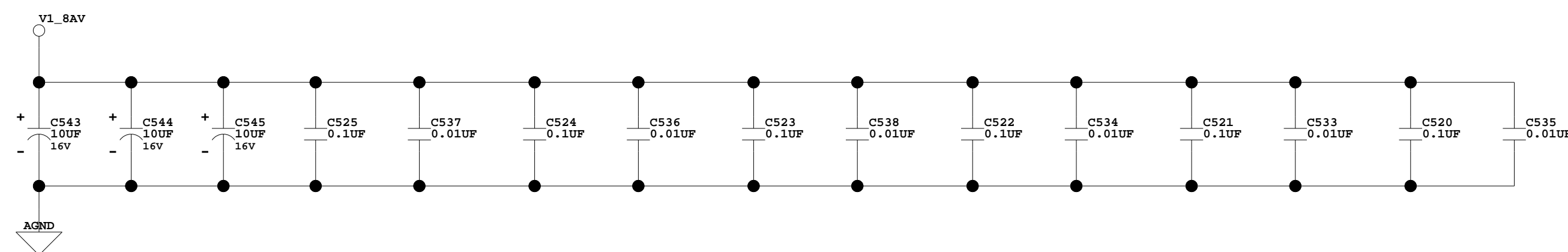
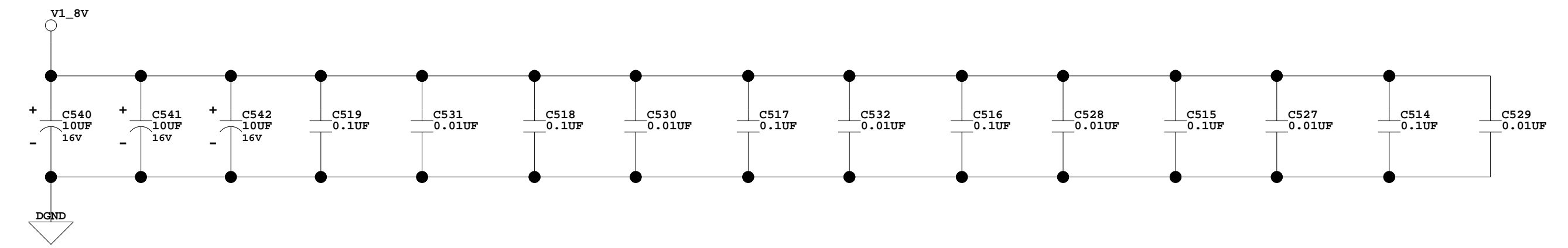
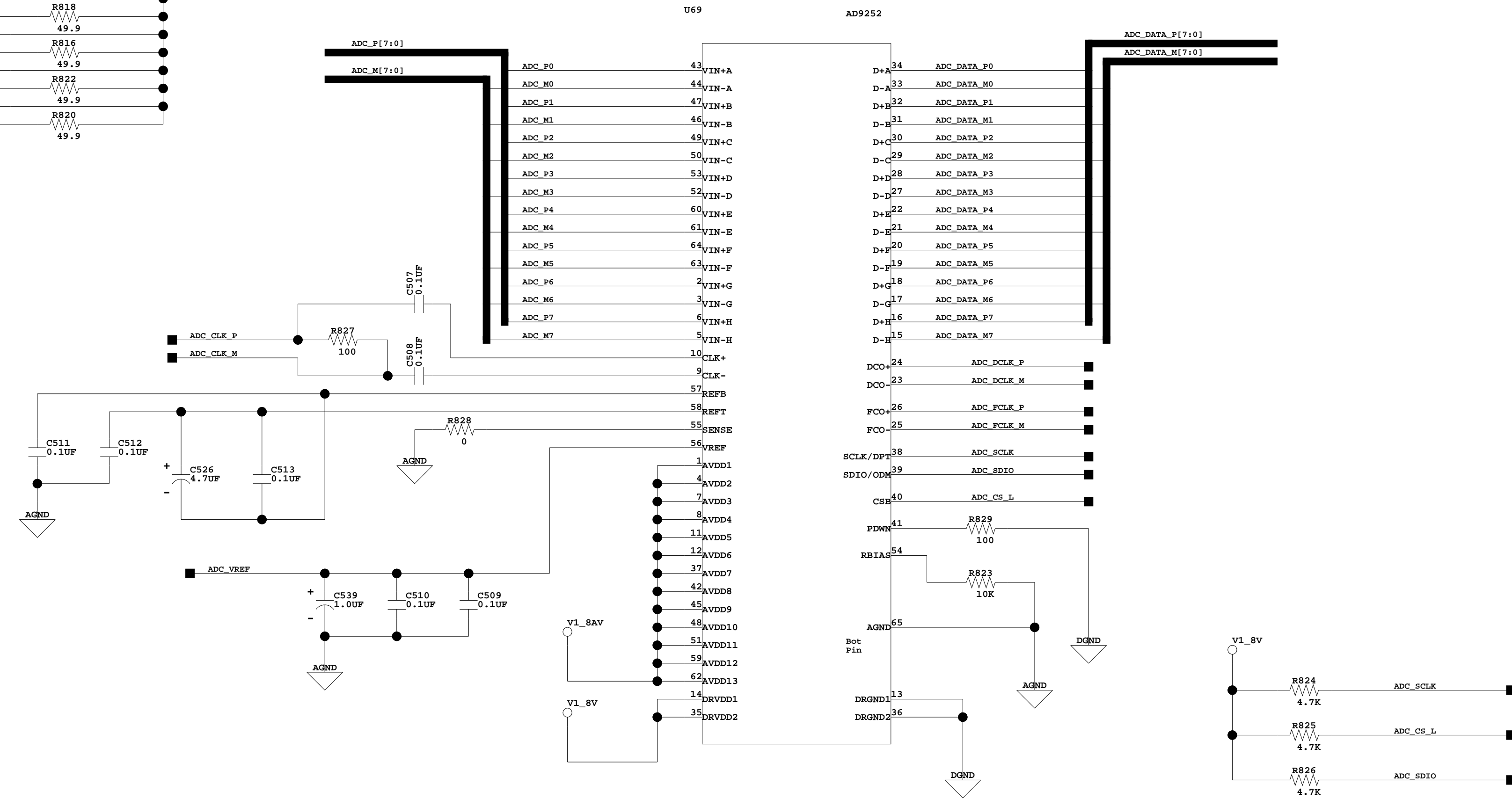
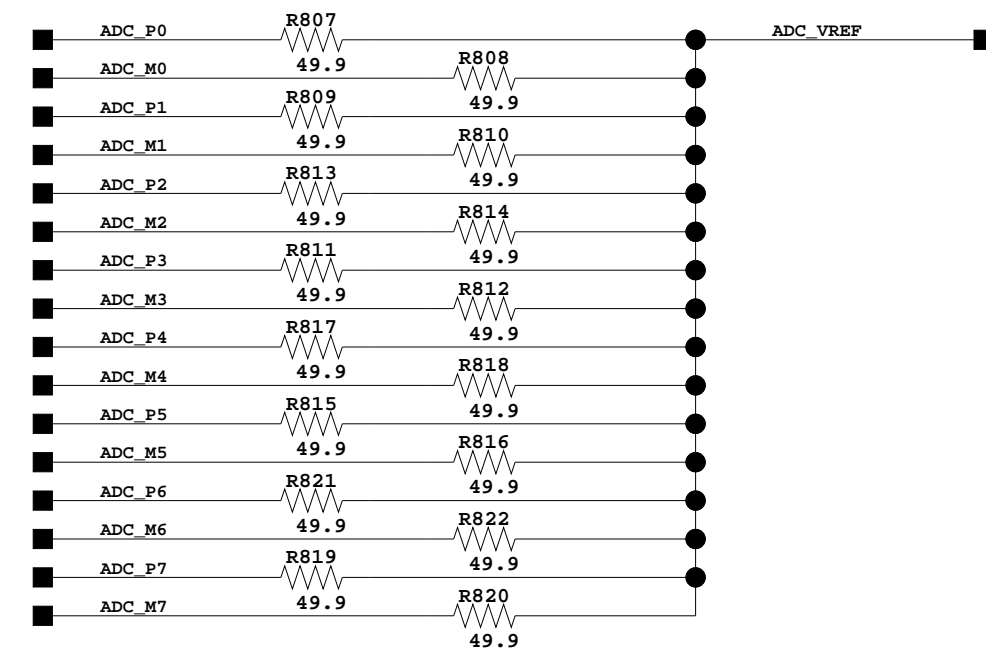

1-24-2011\_15:38

SLAC NATIONAL ACCELERATOR LABORATORY U.S. DEPARTMENT OF ENERGY		SHEET 20 OF 23
STANFORD UNIVERSITY STANFORD, CALIFORNIA		HEAVY P TRACKER READOUT RTM 8 CHANNEL ADC
PROPRIETARY DATA OF STANFORD UNIVERSITY AND/OR U.S. DEPARTMENT OF ENERGY. RECIPIENT SHALL NOT PUBLISH THE INFORMATION WITHIN UNLESS GRANTED SPECIFIC PERMISSION OF STANFORD UNIVERSITY.		
INGR Ryan Herbst	DATE 2010	APPROVALS
DPTH		LOCATED AT SHEET 18
CDRS		SD-249-901-02-C01

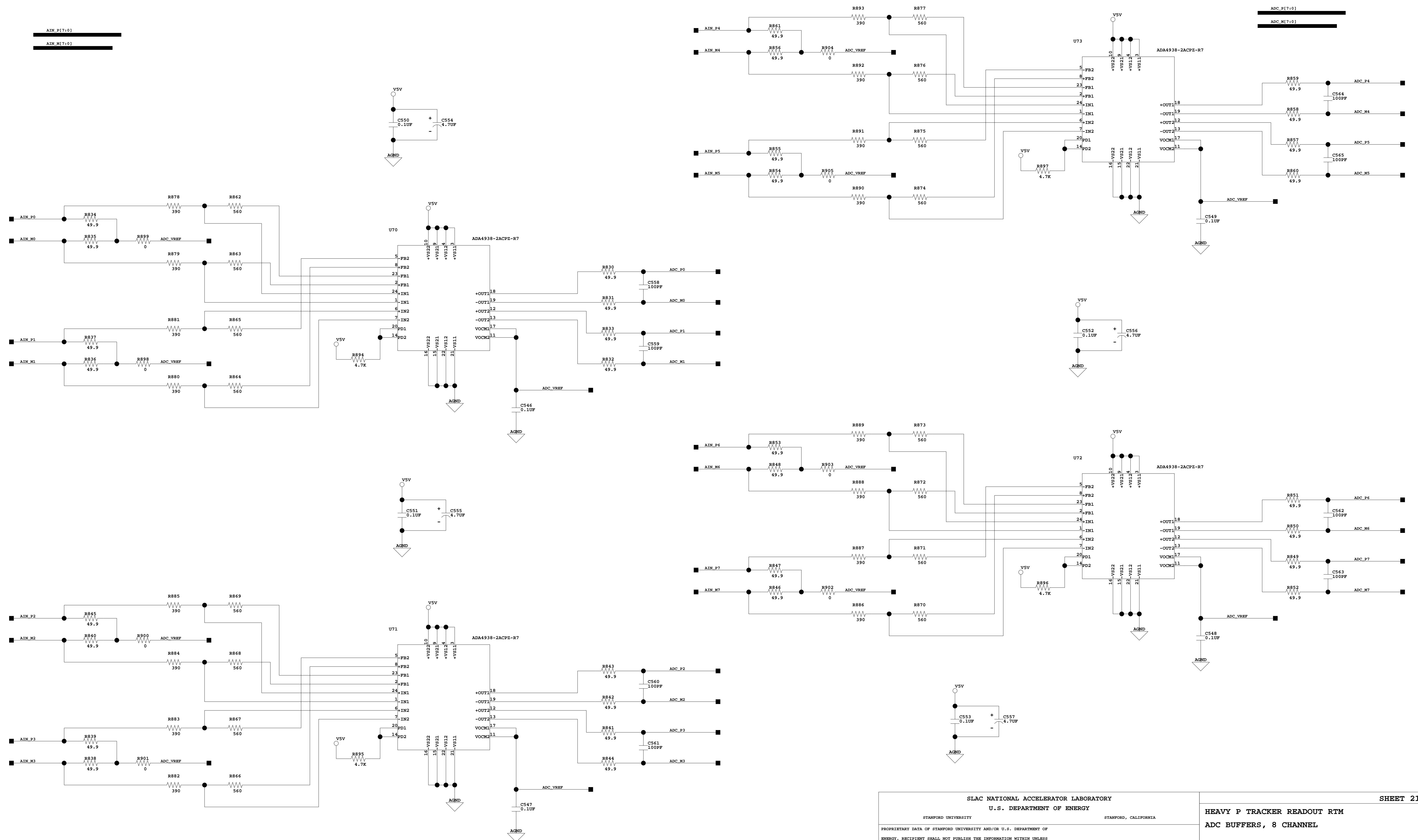

1-24-2011\_15:38

SLAC NATIONAL ACCELERATOR LABORATORY  
 U.S. DEPARTMENT OF ENERGY

STANFORD UNIVERSITY STANFORD, CALIFORNIA

PROPRIETARY DATA OF STANFORD UNIVERSITY AND/OR U.S. DEPARTMENT OF ENERGY. RECIPIENT SHALL NOT PUBLISH THE INFORMATION WITHIN UNLESS GRANTED SPECIFIC PERMISSION OF STANFORD UNIVERSITY.

INCR	DATE	APPROVALS
DRFR	Ryan Herbat	2010
CDR		
INCR		

SHEET 21 OF 23

HEAVY P TRACKER READOUT RTM  
 ADC BUFFERS, 8 CHANNEL

LOCATED AT SHEET 18

SD-249-901-02-C01

**ADC INPUT TERMINATION  
PLACE NEAR ADC**

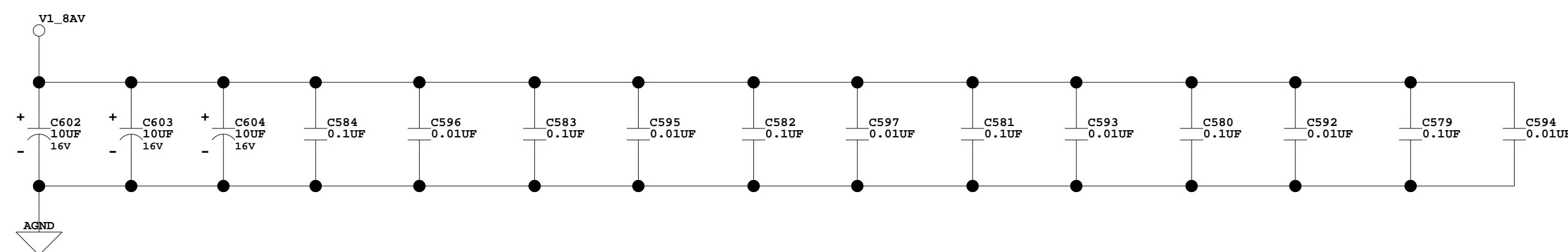
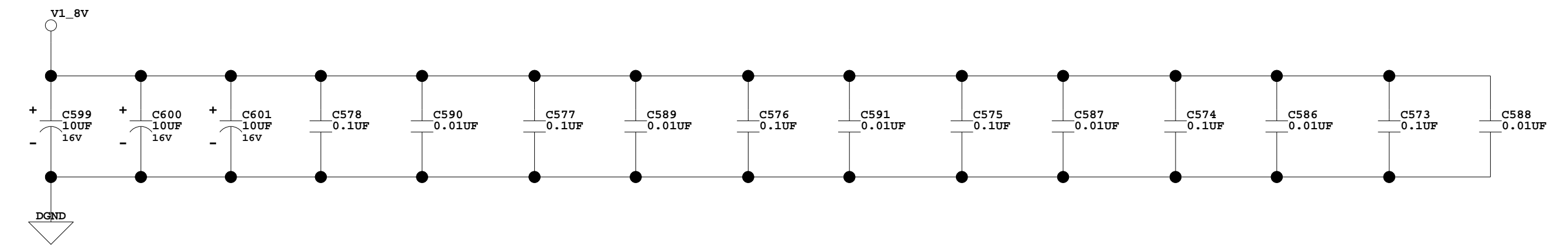
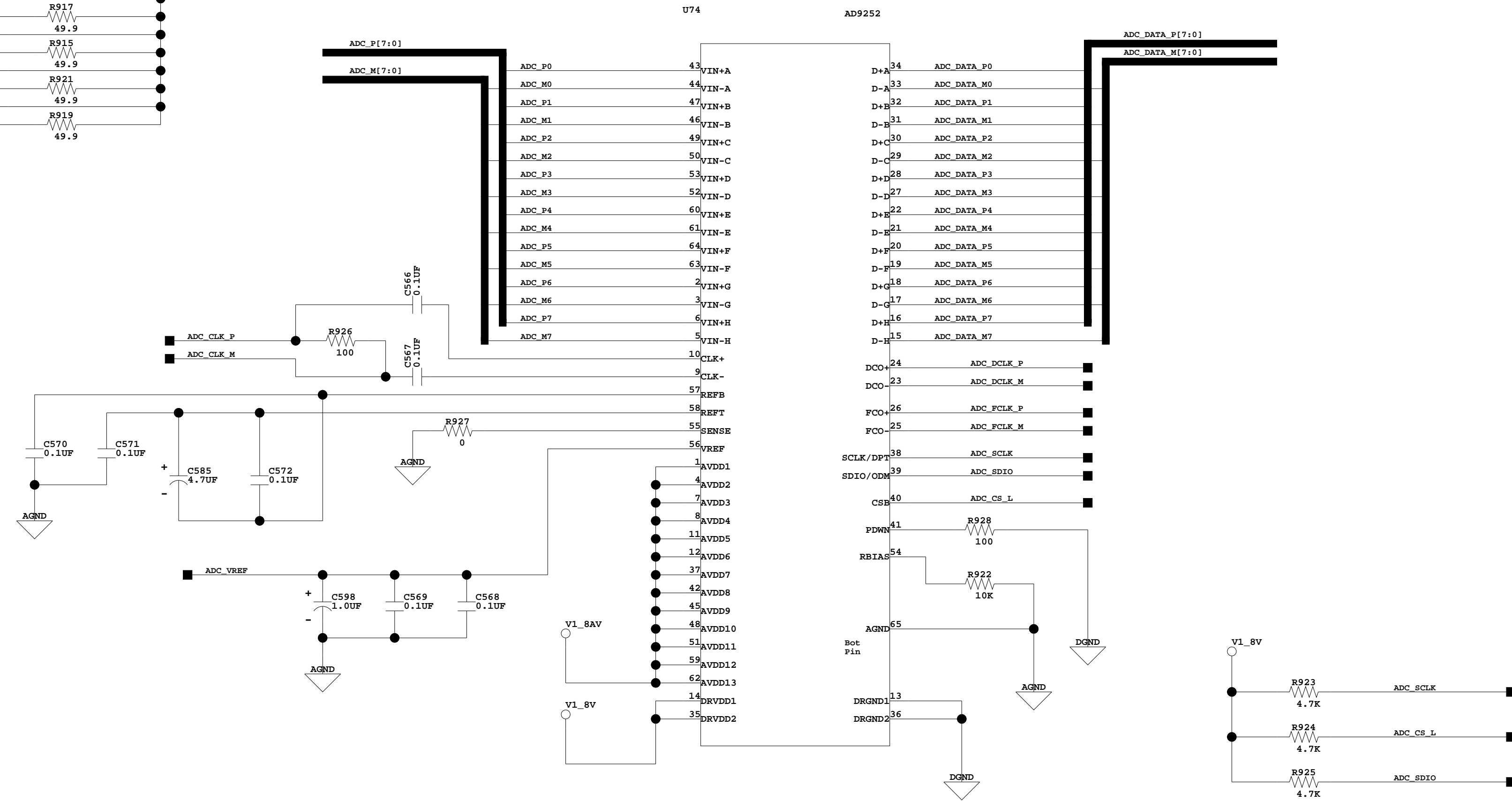
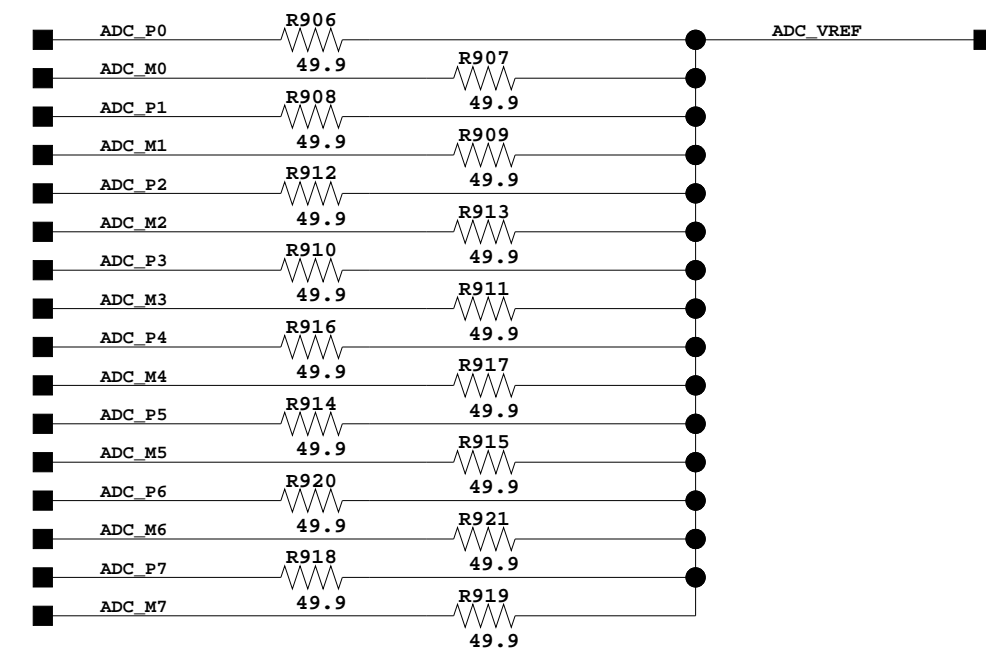

1-24-2011\_15:38

SLAC NATIONAL ACCELERATOR LABORATORY U.S. DEPARTMENT OF ENERGY		SHEET 22 OF 23
STANFORD UNIVERSITY STANFORD, CALIFORNIA		HEAVY P TRACKER READOUT RTM 8 CHANNEL ADC
PROPRIETARY DATA OF STANFORD UNIVERSITY AND/OR U.S. DEPARTMENT OF ENERGY. RECIPIENT SHALL NOT PUBLISH THE INFORMATION WITHIN UNLESS GRANTED SPECIFIC PERMISSION OF STANFORD UNIVERSITY.		
INGR	Ryan Herbat	DATE
DPTH		2010
CDRS		APPROVALS
LOCATED AT SHEET 18		
SD-249-901-02-C01		

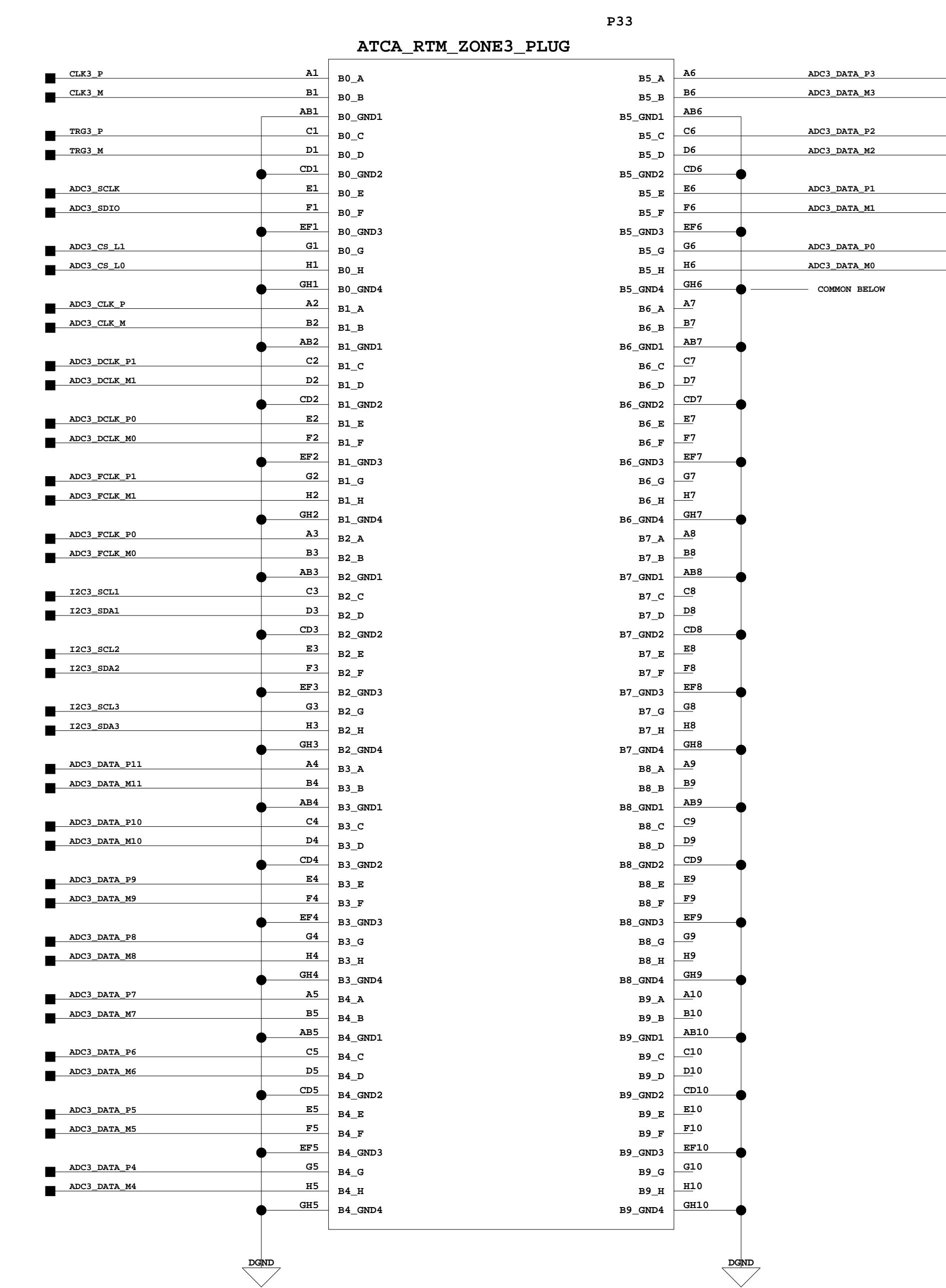
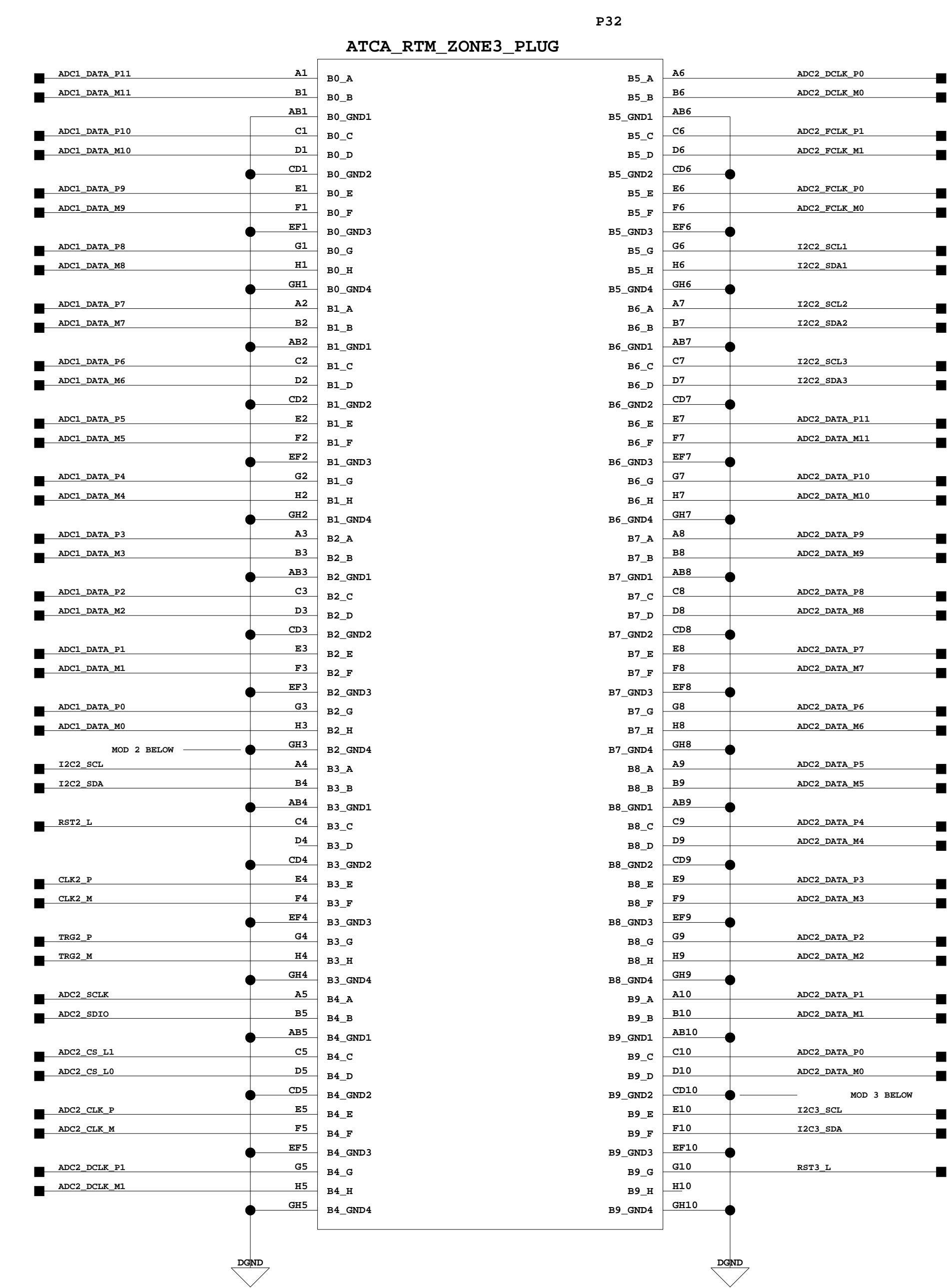
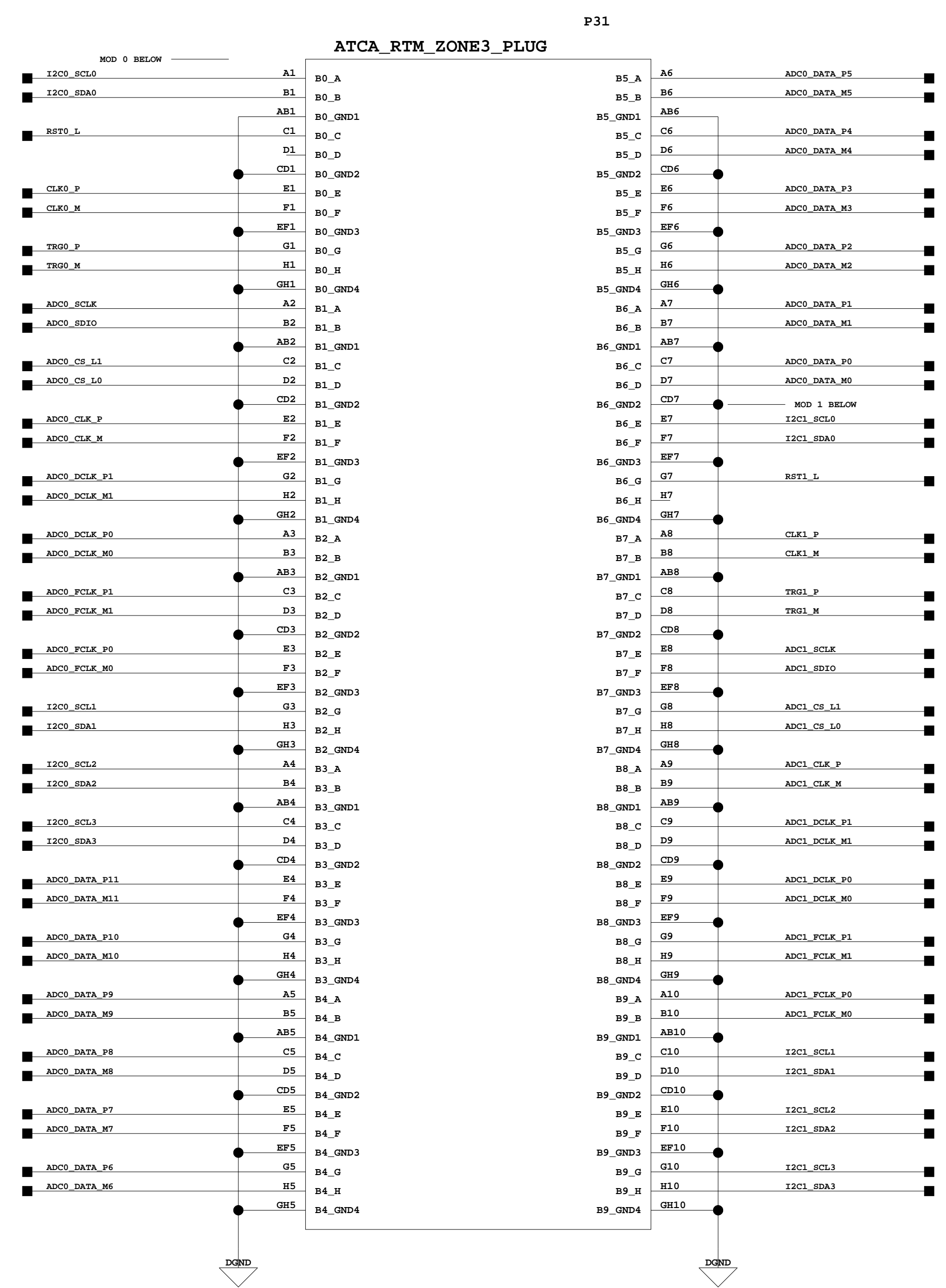

- I2C[3:0].SCL[3:0]
- I2C[3:0].SDA[3:0]
- RST[3:0].L
- CLK[3:0].P
- CLK[3:0].M
- TRG[3:0].P
- TRG[3:0].M
- ADC[3:0].DCLK\_P[1:0]
- ADC[3:0].DCLK\_M[1:0]
- ADC[3:0].FCLK\_P[1:0]
- ADC[3:0].FCLK\_M[1:0]
- ADC[3:0].DATA\_P[15:0]
- ADC[3:0].DATA\_M[15:0]
- ADC[3:0].SCLK
- ADC[3:0].SDIO
- ADC[3:0].CS\_L[1:0]
- ADC[3:0].CLK\_P
- ADC[3:0].CLK\_M

1-24-2011\_15:38

STANFORD UNIVERSITY U.S. DEPARTMENT OF ENERGY STANFORD, CALIFORNIA

PROPRIETARY DATA OF STANFORD UNIVERSITY AND/OR U.S. DEPARTMENT OF ENERGY. RECIPIENT SHALL NOT PUBLISH THE INFORMATION WITHIN UNLESS GRANTED SPECIFIC PERMISSION OF STANFORD UNIVERSITY.

INGR	DATE	APPROVALS
Ryan Herbat	2010	

SHEET 23 OF 23

HEAVY P TRACKER READOUT RTM ZONE 3 CONNECTOR

LOCATED AT SHEET 1

SD-249-901-02-C01

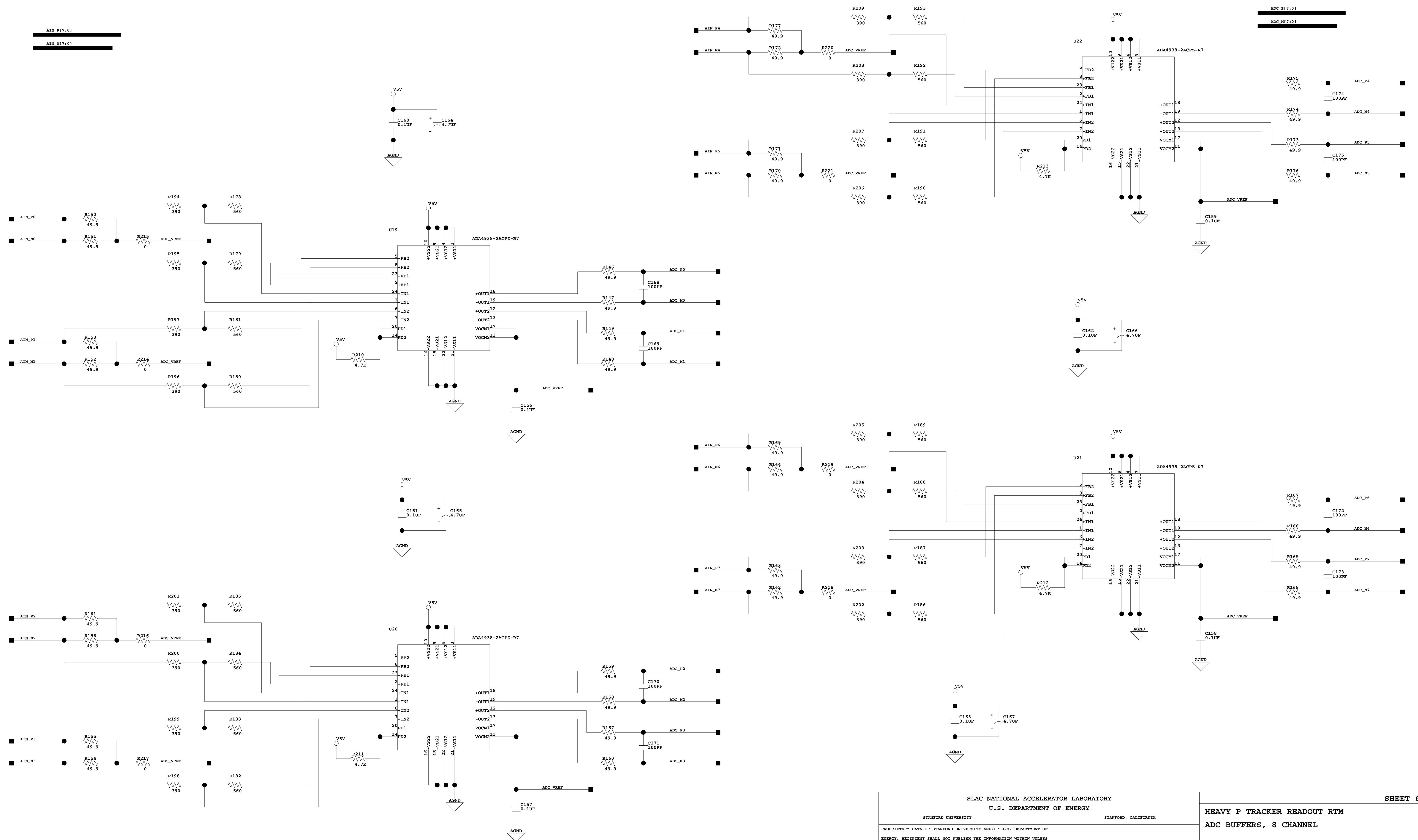

1-24-2011\_15:38

<b>SLAC NATIONAL ACCELERATOR LABORATORY</b> <b>U.S. DEPARTMENT OF ENERGY</b>		
STANFORD UNIVERSITY	STANFORD, CALIFORNIA	
<small>PROPRIETARY DATA OF STANFORD UNIVERSITY AND/OR U.S. DEPARTMENT OF ENERGY. RECIPIENT SHALL NOT PUBLISH THE INFORMATION WITHIN UNLESS GRANTED SPECIFIC PERMISSION OF STANFORD UNIVERSITY.</small>		
INDR	DATE	APPROVALS
DFR	2010	
CDR		

SHEET 6 OF 23

**HEAVY P TRACKER READOUT RTM**  
**ADC BUFFERS, 8 CHANNEL**

LOCATED AT SHEET 3  
SD-249-901-02-C01