

# ***Turbo-V 301-AG Rack Controller***

**Model 969-8991  
Model 969-8992  
Model 969-8993**

- (I) MANUALE DI ISTRUZIONI*
- (D) BEDIENUNGSHANDBUCH*
- (F) NOTICE DE MODE D'EMPLOI*
- (E) MANUAL DE INSTRUCCIONES*
- (P) MANUAL DE INSTRUÇÕES*
- (NL) BEDRIJFSHANDLEIDING*
- (DK) INSTRUKSTIONSBOG*
- (S) BRUKSANVISNING*
- (N) INSTRUKSJON MANUAL*
- (FIN) OHJEKÄSIKIRJA*
- (GR) ΟΔΗΓΙΕΣ ΧΡΗΣΕΩΣ*
- (H) FELHASZNÁLÓI KÉZIKÖNYV*
- (PL) PODRECZNIK INSTRUKCJI*
- (CZ) NÁVOD K POUŽITÍ*
- (SK) NÁVOD NA OBSLUHU*
- (SLO) PRIROČNIK ZA NAVODILA*
- (GB) INSTRUCTION MANUAL*

# ***Turbo-V 301-AG Rack Controller***



**VARIAN**



*vacuum technologies*

*Dear Customer,*

*Thank you for purchasing a VARIAN vacuum product. At VARIAN Vacuum Technologies we make every effort to ensure that you will be satisfied with the product and/or service you have purchased.*

*As part of our Continuous Improvement effort, we ask that you report to us any problem you may have had with the purchase or operation of our product. On the back side you find a Corrective Action Request form that you may fill out in the first part and return to us.*

*This form is intended to supplement normal lines of communications and to resolve problems that existing systems are not addressing in an adequate or timely manner.*

*Upon receipt of your Corrective Action Request we will determine the Root Cause of the problem and take the necessary actions to eliminate it. You will be contacted by one of our employees who will review the problem with you and update you, with the second part of the same form, on our actions.*

*Your business is very important to us. Please, take the time and let us know how we can improve.*

*Sincerely,*

**Sergio PIRAS**

*Vice President and General Manager  
VARIAN Vacuum Technologies*

*Note: Fax or mail the Customer Request for Action (see backside page) to VARIAN Vacuum Technologies (Torino) - Quality Assurance or to your nearest VARIAN representative for onward transmission to the same address.*

**CUSTOMER REQUEST FOR CORRECTIVE / PREVENTIVE / IMPROVEMENT ACTION**

TO : VARIAN VACUUM TECHNOLOGIES TORINO - QUALITY ASSURANCE

FAX N° : XXXX - 011 - 9979350

ADDRESS: VARIAN S.p.A. - Via F.lli Varian, 54 - 10040 Leinì (Torino) - Italy

E-MAIL : marco.marzio@varianinc.com

NAME _____	COMPANY _____	FUNCTION _____
<p>ADDRESS : _____</p> <p>TEL. N° : _____ FAX N° : _____</p> <p>E-MAIL : _____</p>		
<p>PROBLEM / SUGGESTION :</p> <p>_____</p> <p>_____</p> <p>_____</p> <p>_____</p>		
<p>REFERENCE INFORMATION (model n°, serial n°, ordering information, time to failure after installation, etc.) :</p> <p>_____</p> <p>_____</p> <p>_____</p> <p style="text-align: right;">DATE _____</p>		

<p>CORRECTIVE ACTION PLAN / ACTUATION (by VARIAN VTT)</p> <p>_____</p> <p>_____</p> <p>_____</p> <p>_____</p> <p>_____</p>	<p>LOG N° _____</p>
--	---------------------

XXXX = Code for dialing Italy from your country ( es. 01139 from USA; 00139 from Japan, etc.)



ISTRUZIONI PER L'USO .....	1
GEBRAUCHSANLEITUNG .....	5
MODE D'EMPLOI.....	9
INSTRUCCIONES DE USO .....	13
INSTRUÇÕES PARA O USO .....	17
GEbruIKSAANWIJZINGEN.....	21
BRUGSANVISNING.....	25
BRUKSANVISNING .....	29
BRUKERVEILEDNING.....	33
KÄYTTÖOHJEET .....	37
ΟΔΗΓΙΕΣ ΧΡΗΣΕΩΣ.....	41
HASZNÁLATI UTASÍTÁS .....	45
INSTRUKCJA UŻYTKOWANIA .....	49
PŘÍRUČKA K POUŽITÍ .....	53
NÁVOD K POUŽITIU .....	57
NAVODILA ZA UPORABO .....	61
INSTRUCTIONS FOR USE .....	65
TECHNICAL INFORMATION .....	69
TURBO-V 301 RACK CONTROLLER DESCRIPTION .....	69
CONTROLLER SPECIFICATIONS .....	70
CONTROLLER OUTLINE .....	70
CONTROLLER CONNECTION.....	71
J6 - Fan .....	71
J7 - Vent.....	71
P1 - Input .....	72
J1 - Output.....	73
Pump Connector .....	77
Pump Driving.....	78
Stop Speed Reading and Active Stop .....	78

J5 - GAUGE CONNECTOR .....	77
J2 - SERIAL CONNECTOR.....	78
Serial Communication Descriptions .....	79
Window Protocol .....	81
Window Meanings .....	83
HOW TO USE FRONT PANEL .....	86
General.....	88
Startup.....	89
Programming.....	91
Configuration menu .....	91
MODE menu.....	92
PUMP SETTING menu .....	92
INPUT/OUTPUT menu.....	93
GAUGE menu .....	94
SERIAL menu.....	95
HOW TO USE BY REMOTE I/O .....	96
HOW TO USE IN SERIAL MODE .....	96
PROFIBUS OPTION .....	97
General.....	97
Installation .....	97
Configuration .....	97
Software Operation and State Machine .....	97
Message Mapping .....	98
Parameter Buffer .....	99
Output Buffer .....	102
Input Buffer.....	103
Diagnostic Management.....	105
Diagnostic Buffer.....	105
ERROR MESSAGES.....	106
ORDERABLE PARTS.....	107

## INFORMAZIONI GENERALI

Questa apparecchiatura è destinata ad uso professionale. L'utilizzatore deve leggere attentamente il presente manuale di istruzioni ed ogni altra informazione addizionale fornita dalla Varian prima dell'utilizzo dell'apparecchiatura. La Varian si ritiene sollevata da eventuali responsabilità dovute all'inosservanza totale o parziale delle istruzioni, ad uso improprio da parte di personale non addestrato, ad interventi non autorizzati o ad uso contrario alle normative nazionali specifiche. I controller della serie Turbo-V 301 Rack sono dei convertitori di frequenza, controllati da un microprocessore, realizzati con componenti a stato solido e con capacità di autodiagnostica e autoprotezione.

Caratteristiche del controller:

- Operatività frontale / remota / seriale
- Pilotaggio a 24 Vdc della ventola di raffreddamento pompa
- Pilotaggio vent valve
- Lettura velocità pompa in seguito al comando di arresto (lettura velocità di arresto)
- Lettura della pressione
- Interfaccia Profibus (opzionale)
- Impostazione automatica tensione di ingresso.

Nei paragrafi seguenti sono riportate tutte le informazioni necessarie a garantire la sicurezza dell'operatore durante l'utilizzo dell'apparecchiatura. Informazioni dettagliate sono fornite nell'appendice "Technical Information".

**Questo manuale utilizza le seguenti convenzioni:**



### PERICOLO!

I messaggi di pericolo attirano l'attenzione dell'operatore su una procedura o una pratica specifica che, se non eseguita in modo corretto, potrebbe provocare gravi lesioni personali.



### ATTENZIONE

I messaggi di attenzione sono visualizzati prima di procedure che, se non osservate, potrebbero causare danni all'apparecchiatura.

### NOTA

*Le note contengono informazioni importanti estrapolate dal testo.*

## IMMAGAZZINAMENTO

Durante il trasporto e l'immagazzinamento dei controller devono essere soddisfatte le seguenti condizioni ambientali:

- temperatura: da -20 °C a +70 °C
- umidità relativa: 0 - 95% (non condensante)

## PREPARAZIONE PER L'INSTALLAZIONE

Il controller viene fornito in un imballo protettivo speciale; se si presentano segni di danni, che potrebbero essersi verificati durante il trasporto, contattare l'ufficio vendite locale.

Durante l'operazione di disimballaggio, prestare particolare attenzione a non lasciar cadere il controller e a non sottoporlo ad urti.

Non disperdere l'imballo nell'ambiente. Il materiale è completamente riciclabile e risponde alla direttiva CEE 85/399 per la tutela dell'ambiente.

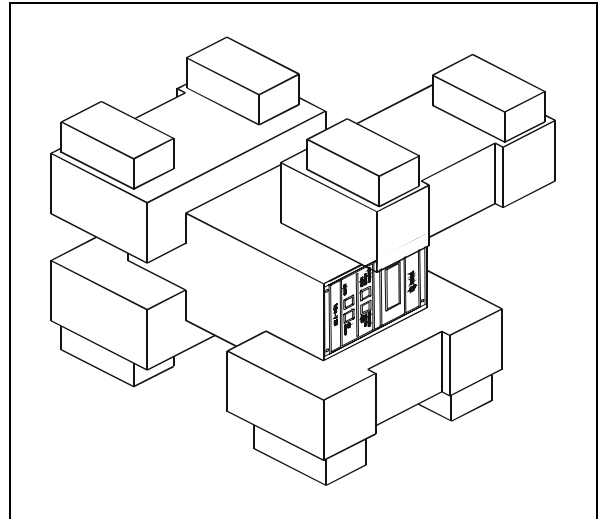

*Imballo dei controller*

## INSTALLAZIONE



### PERICOLO!

Il controller deve essere alimentato mediante un cavo di alimentazione a tre fili (vedere tabella delle parti ordinabili) con una spina di tipo approvato a livello internazionale ai fini della sicurezza dell'utente. Utilizzare sempre questo cavo di alimentazione ed inserire la spina in una presa con un adeguato collegamento di terra onde evitare scariche elettriche e per rispettare le specifiche CE. All'interno del controller si sviluppano alte tensioni che possono recare gravi danni o la morte. Prima di eseguire qualsiasi operazione di installazione o manutenzione del controller scollegarlo dalla presa di alimentazione.

### NOTA

Il controller può essere installato su di un tavolo o all'interno di un apposito rack. In ogni caso occorre che l'aria di raffreddamento possa circolare liberamente intorno all'apparato. Non installare e/o utilizzare il controller in ambienti esposti ad agenti atmosferici (pioggia, gelo, neve), polveri, gas aggressivi, in ambienti esplosivi o con elevato rischio di incendio.

Durante il funzionamento è necessario che siano rispettate le seguenti condizioni ambientali:

- temperatura: da 5 °C a +45 °C
- umidità relativa: 0 - 95% (non condensante).

Per gli altri collegamenti e l'installazione degli accessori opzionali, vedere la sezione "Technical Information".

## USO

In questo paragrafo sono riportate le principali procedure operative. Per ulteriori dettagli e per procedure che coinvolgono collegamenti o particolari opzionali, fare riferimento al paragrafo "Use" dell'appendice "Technical Information".

Prima di usare il controller effettuare tutti i collegamenti elettrici e pneumatici e fare riferimento al manuale della pompa collegata.



### PERICOLO!

Per evitare danni alle persone ed all'apparato, nel caso in cui la pompa sia appoggiata su di un tavolo assicurarsi che sia stabile. Non far funzionare mai la pompa se la flangia di ingresso non è collegata al sistema o non è chiusa con la flangia di chiusura.

### NOTA

Il connettore di richiusura J1 deve essere lasciato collegato con il suo ponticello se non viene effettuato alcun collegamento esterno. La pompa di pre-vuoto e la pompa Turbo-V possono essere accese contemporaneamente.

## Comandi, indicatori e connettori

Di seguito sono illustrati il pannello frontale e posteriore del controller. Per maggiori dettagli fare riferimento alla sezione "Technical Information".

### Descrizione pannello frontale

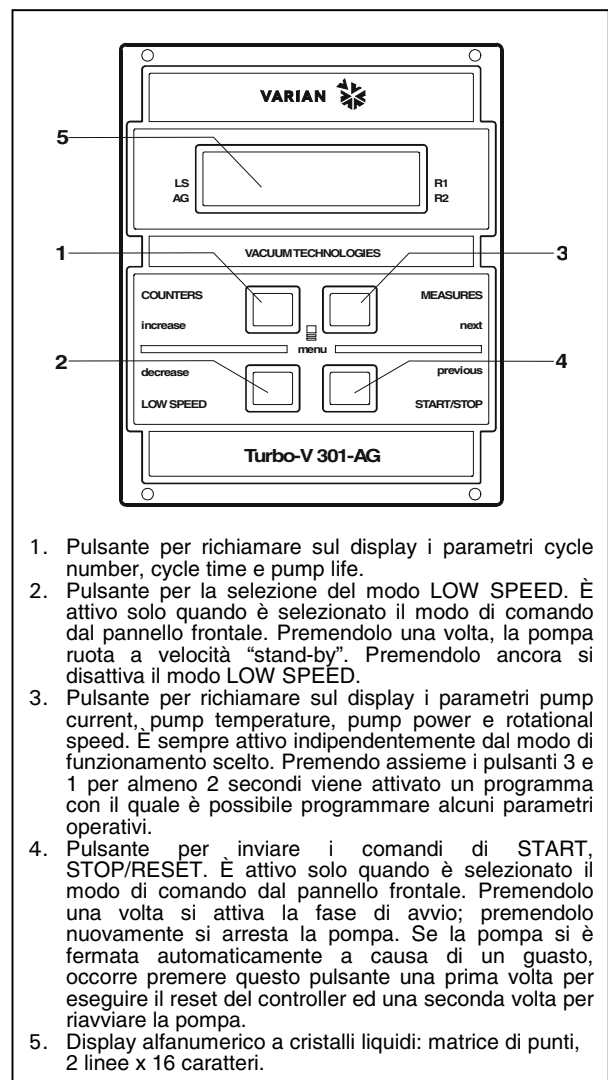

1. Pulsante per richiamare sul display i parametri cycle number, cycle time e pump life.
2. Pulsante per la selezione del modo LOW SPEED. È attivo solo quando è selezionato il modo di comando dal pannello frontale. Premendolo una volta, la pompa ruota a velocità "stand-by". Premendolo ancora si disattiva il modo LOW SPEED.
3. Pulsante per richiamare sul display i parametri pump current, pump temperature, pump power e rotational speed. È sempre attivo indipendentemente dal modo di funzionamento scelto. Premendo assieme i pulsanti 3 e 1 per almeno 2 secondi viene attivato un programma con il quale è possibile programmare alcuni parametri operativi.
4. Pulsante per inviare i comandi di START, STOP/RESET. È attivo solo quando è selezionato il modo di comando dal pannello frontale. Premendolo una volta si attiva la fase di avvio; premendolo nuovamente si arresta la pompa. Se la pompa si è fermata automaticamente a causa di un guasto, occorre premere questo pulsante una prima volta per eseguire il reset del controller ed una seconda volta per riavviare la pompa.
5. Display alfanumerico a cristalli liquidi: matrice di punti, 2 linee x 16 caratteri.

Pannello frontale del Controller Turbo-V 301-AG



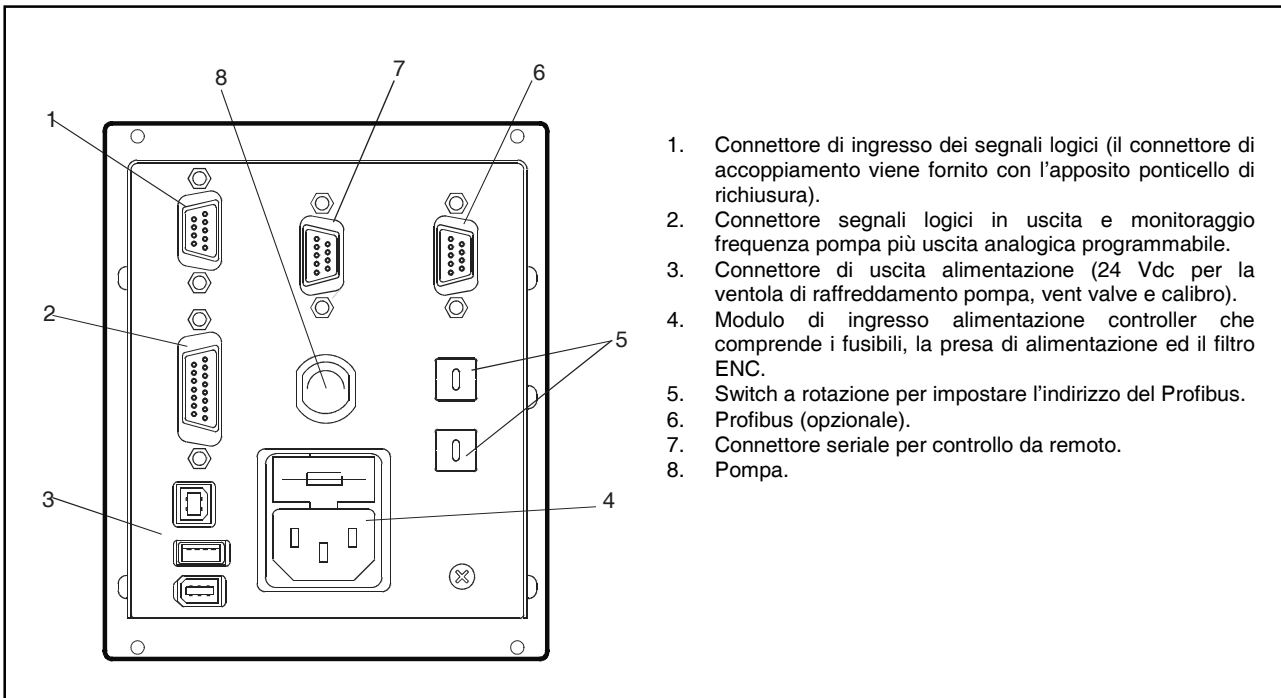

Pannello posteriore dei Controller Turbo-V301-AG

**PROCEDURE DI USO**

**Accensione del Controller**

Per accendere il controller è sufficiente inserire il cavo di alimentazione nella presa di rete.

**Avvio della Pompa**

Per avviare la pompa occorre abilitare l'ingresso di interlock e premere il pulsante START del pannello frontale.

**Arresto della Pompa**

Per arrestare la pompa occorre premere il pulsante STOP del pannello frontale.

**MANUTENZIONE**

I controller della serie Turbo-V 301 Rack non richiedono alcuna manutenzione. Qualsiasi intervento deve essere eseguito da personale autorizzato.

In caso di guasto è possibile usufruire del servizio di riparazione Varian o del "Varian advance exchange service", che permette di ottenere un controller rigenerato in sostituzione di quello guasto.

**SMALTIMENTO**

**Significato del logo "WEEE" presente sulle etichette.**

Il simbolo qui sotto riportato è applicato in ottemperanza alla direttiva CE denominata "WEEE". Questo simbolo (**valido solo per i paesi della Comunità Europea**) indica che il prodotto sul quale è applicato, NON deve essere smaltito insieme ai comuni rifiuti domestici o industriali, ma deve essere avviato ad un sistema di raccolta differenziata. Si invita pertanto l'utente finale a contattare il fornitore del dispositivo, sia esso la casa madre o un rivenditore, per avviare il processo di raccolta e smaltimento, dopo opportuna verifica dei termini e condizioni contrattuali di vendita.

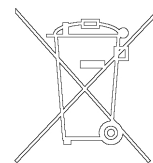

**PERICOLO!**

Prima di effettuare qualsiasi intervento sul controller scollegare il cavo di alimentazione.

Qualora un controller dovesse essere rottamato, procedere alla sua eliminazione nel rispetto delle normative nazionali specifiche.

**MESSAGGI DI ERRORE**

In alcuni casi di guasto la circuiteria di autodiagnosi del controller presenta alcuni messaggi di errore elencati nella tabella seguente.

<b>MESSAGGIO</b>	<b>DESCRIZIONE</b>	<b>AZIONE CORRETTIVA</b>
<b>CHECK CONNECTION TO PUMP</b>	Malfunzionamento nel collegamento tra pompa e controller. Oppure La pompa ha una temperatura inferiore a 0 °C.	Verificare che il cavo di collegamento tra pompa e controller sia ben fissato da entrambe le estremità e non sia interrotto. Premere due volte il pulsante START per riavviare la pompa.
<b>WAITING INTERLOCK</b>	È attivo il segnale di interlock presente sul connettore P1 a causa dell'interruzione del corto circuito tra il pin 3 ed il pin 8 del connettore J1, o a causa dell'apertura del segnale di interlock esterno.	Ripristinare il corto circuito tra il pin 3 ed il pin8 del connettore J1, o chiudere il segnale di interlock esterno.
<b>PUMP OVERTEMP.</b>	La temperatura del cuscinetto superiore o della pompa ha superato i 60 °C.	Attendere che la temperatura ritorni al di sotto della soglia. Premere due volte il pulsante START per riavviare la pompa.
<b>CONTROLLER OVERTEMP.</b>	La temperatura dell'ambiente del controller ha superato i 70 °C. Oppure La temperatura del radiatore del controller è superiore a 60 °C.	Attendere che la temperatura ritorni al di sotto della soglia. Premere due volte il pulsante START per riavviare la pompa.
<b>TOO HIGH LOAD</b>	La corrente assorbita dalla pompa è maggiore di quella programmata.	Verificare che il rotore della pompa abbia la possibilità di ruotare liberamente. Premere due volte il pulsante START per riavviare la pompa.
<b>SHORT CIRCUIT</b>	Durante il funzionamento normale (dopo la fase di avvio) la connessione di uscita è in corto circuito.	Verificare i collegamenti tra pompa e controller. Premere due volte il pulsante START per riavviare la pompa.
<b>SYSTEM OVERRIDE</b>	La pompa è stata fermata da un segnale di emergenza proveniente da un contatto remoto.	Staccare il cavo di alimentazione del controller e correggere la causa dell'emergenza. Ricollegare il cavo di alimentazione e premere due volte il pulsante START per riavviare la pompa.
<b>OVERVOLTAGE</b>	Si è verificato un guasto nella sezione di alimentazione del controller, o il controller ha ricevuto un segnale spurio.	Premere due volte il pulsante START per riavviare la pompa. Se il messaggio si ripresenta rivolgersi in Varian per la manutenzione.
<b>POWER FAIL</b>	Guasto nella sezione di alimentazione della pompa, del controller.	Rivolgersi alla Varian per Manutenzione.

**ALLGEMEINES**

Dieser Apparat ist für Fachbetriebe bestimmt. Vor Gebrauch sollte der Benutzer dieses Handbuch sowie alle weiteren mitgelieferten Zusatzdokumentationen genau lesen. Bei Nichtbeachtung - auch teilweise - der enthaltenen Hinweise, unsachgemäßem Gebrauch durch ungeschultes Personal, nicht autorisierten Eingriffen und Mißachtung der einheimischen, hier zur Geltung kommenden Bestimmungen übernimmt die Firma Varian keinerlei Haftung.

Die Controller der Serie Turbo-V 301 Rack sind mikroprozessorgesteuerte Frequenzwandler. Sie sind mit Festkörperbauteilen gefertigt und verfügen über ein Selbstdiagnose- und ein Selbstschutzsystem.

Controllereigenschaften:

- Konsol-, Fern- und serielle Operationen
- 24V= Kühlventilator-Treiber
- Vent Valve Treiber
- Auslesen der Pumpgeschwindigkeit nach Stoppbefehl (Lesen der Stoppgeschwindigkeit)
- Auslesen des Drucks
- Profibus-Schnittstelle (Option)
- automatische Einstellung der Eingangsspannung

In den folgenden Abschnitten sind alle erforderlichen Informationen für die Sicherheit des Bedieners bei der Anwendung des Geräts aufgeführt. Detaillierte technische Informationen sind im Anhang "Technical Information" enthalten.

**In dieser Gebrauchsanleitung werden Sicherheitshinweise folgendermaßen hervorgehoben:**



**GEFAHR!**

Die Gefahrenhinweise lenken die Aufmerksamkeit des Bedieners auf eine bestimmte Prozedur oder Praktik, die bei unkorrekter Ausführung schwere Verletzungen hervorrufen können.



**ACHTUNG!**

Die Warnhinweise vor bestimmten Prozeduren machen den Bediener darauf aufmerksam, daß bei Nichteinhaltung Schäden an der Anlage entstehen können.

**ANMERKUNG**

*Die Anmerkungen enthalten wichtige Informationen, ie aus dem Text hervorgehoben werden.*

**LAGERUNG**

Beim Transport und bei der Lagerung der Controller müssen folgende klimatische Verhältnisse eingehalten werden:

- Temperatur: von -20 °C bis +70 °C
- Relative Luftfeuchtigkeit: 0-95% (nicht kondensierend)

**VOR DER INSTALLATION**

Der Controller wird mit einer speziellen Schutzverpackung geliefert. Eventuelle Transportschäden müssen der zuständigen örtlichen Verkaufsstelle gemeldet werden.

Beim Auspacken vorsichtig vorgehen, damit der Controller nicht fällt oder Stößen ausgesetzt wird.

Das Verpackungsmaterial muß korrekt entsorgt werden. Es ist vollständig recyclebar und entspricht der EG-Richtlinie 85/399 für Umweltschutz.

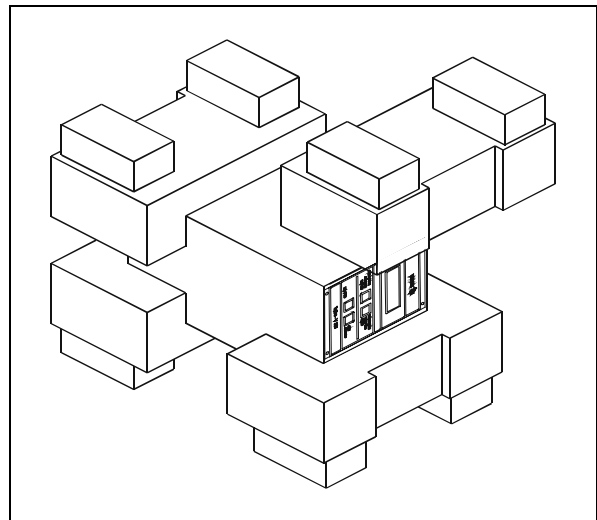

*Verpackung der Controller*

INSTALLATION



**GEFAHR!**

Der Turbo-V Controller muss mit einem dreidradigen Netzkabel und dem (international zugelassenen) Stecker angeschlossen werden. Es sollte immer dieses Netzkabel benutzt werden, das an eine korrekt geerdete Steckdose anzuschließen ist, um den CE Richtlinien zu entsprechen und Stromschläge zu vermeiden. Im Inneren des Controllers entstehen hohe Spannungen, die schwere Verletzungen verursachen und lebensgefährlich sein können. Vor jedem Montage- bzw. Wartungseingriff muss deshalb der Netzstecker gezogen werden.

**ANMERKUNG**

Der Controller kann auf einen Tisch oder ein Gestell montiert werden. In beiden Fällen muß auf die ungehinderte Zirkulation der Kühlluft im Bereich des Geräts geachtet werden.

Der Controller darf nicht in Umgebungen installiert u/o benutzt werden, die Witterungseinflüssen (Regen, Frost, Schnee), Staub und aggressiven Gasen ausgesetzt sind und in denen Explosions- und erhöhte Brandgefahr besteht.

Beim Betrieb müssen folgende Umgebungsbedingungen eingehalten werden:

- Temperatur: von +5 °C bis +45 °C
- Relative Luftfeuchtigkeit: 0 - 95 % (nicht kondensierend).

**GEBRAUCH**

In diesem Kapitel sind die wichtigsten Betriebsvorgänge aufgeführt. Für weitere Hinweise bezüglich Anschlüsse und Montage des bestellbaren Zubehörs siehe Kapitel "Use" im Anhang zu "Technical Information".

Vor Benutzung des Controllers sämtliche elektrischen und pneumatischen Anschlüsse ausführen, und die Betriebsanleitung der angeschlossenen Pumpe durchlesen.



**GEFAHR!**

Steht die Pumpe auf einem Tisch, muß auf den stabilen Stand geachtet werden, da sonst die Gefahr von Personen- und Geräteschäden besteht. Die Pumpe nie einschalten, wenn der Eingangsflansch nicht am System angeschlossen bzw. nicht mit dem Schließflansch abgedeckt ist.

**ANMERKUNG**

Der Wiederverschließ-Verbinder J1 muß mit seiner Brücke angeschlossen bleiben, wenn kein externer Anschluß erfolgt. Die Vorvakuumpumpe und die Turbo-V-Pumpe können gleichzeitig eingeschaltet werden.

**Steuerungen, Anzeigen und Verbinder des Controllers**

Der folgende Abschnitt beschreibt die vordere und hintere Konsole des Controllers. Für weitere Einzelheiten siehe "Technical Information".

**Fronttafel der Controller**

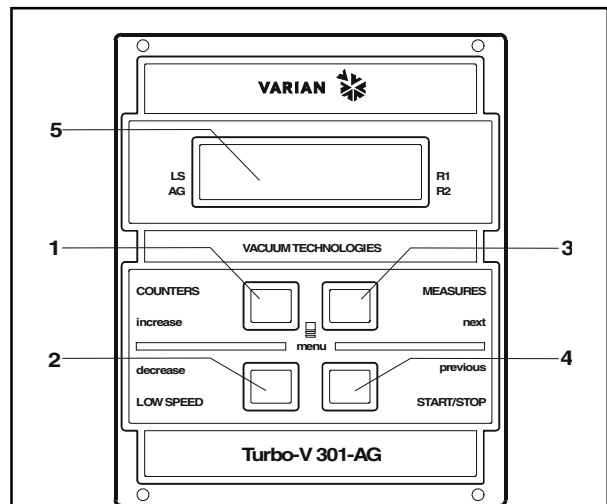

1. Taste für die Anzeige der Parameter "cycle number", "cycle time" und "pump life".
2. Taste für die Einstellung des Modus LOW SPEED. Sie ist nur aktiv, wenn der Steuermodus auf Fronttafel eingestellt ist. Bei einmaligem Drücken läuft die Pumpe in Bereitschafts-Geschwindigkeit. Bei nochmaligem Drücken wird der Modus LOW SPEED deaktiviert.
3. Taste für die Anzeige der Parameter "pump current", "pump temperature", "pump power" und "rational speed". Sie ist immer aktiv, unabhängig vom gewählten Betriebsmodus. Bei gemeinsamer, mindestens 2 Sekunden langer Betätigung der Tasten 3 und 1 wird ein Programm aktiviert, mit dem einige Betriebsparameter programmiert werden können.
4. START-, STOP/RESET-Taste. Sie ist nur aktiv, wenn der Steuermodus auf der Fronttafel eingestellt ist. Bei einmaligem Drücken wird die Startphase aktiviert. Bei nochmaligem Drücken stoppt die Pumpe. Bei automatischem Pumpenstopp durch Störung muß diese Taste ein erstes Mal zur Controller-Rücksetzung und dann ein zweites Mal zum Neustarten der Pumpe gedrückt werden.
5. Alphanumerisches Flüssigkristall-Display: Punkt-matrix, 2 Zeilen mit 16 Stellen.

Fronttafel der Controller Turbo-V 301-AG

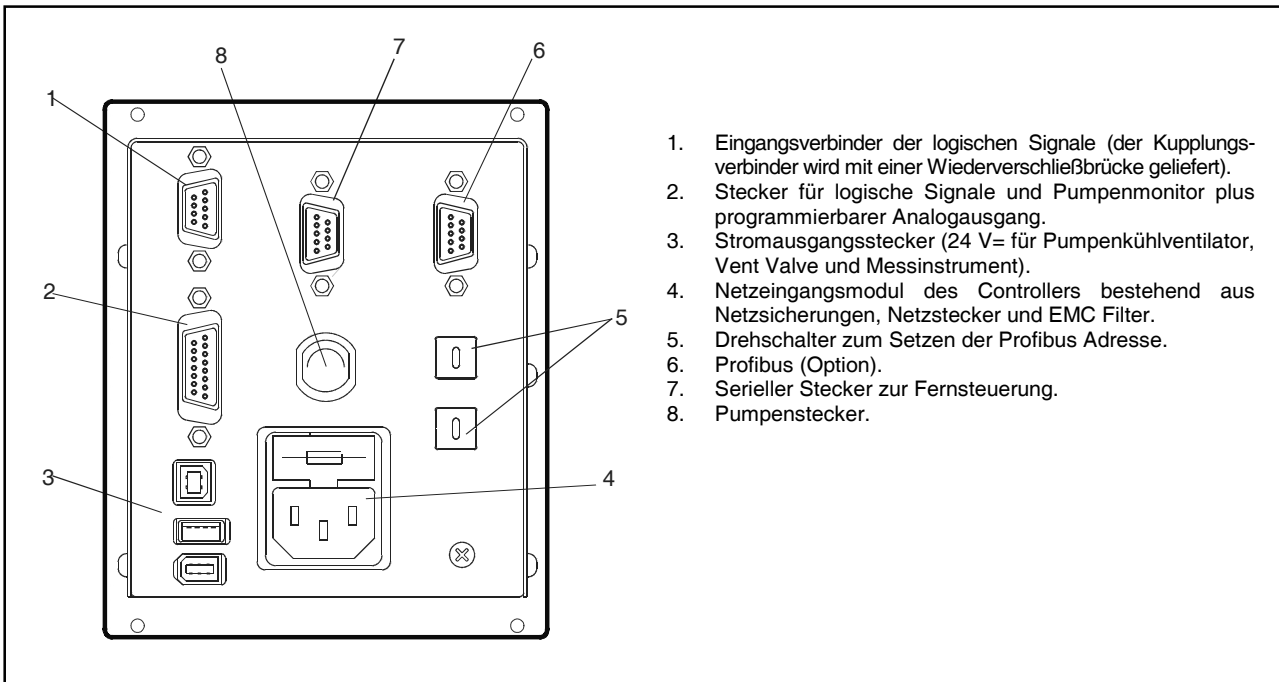

1. Eingangsverbinder der logischen Signale (der Kupplungsverbinder wird mit einer Wiederverschließbrücke geliefert).
2. Stecker für logische Signale und Pumpenmonitor plus programmierbarer Analogausgang.
3. Stromausgangsstecker (24 V= für Pumpenkühlventilator, Vent Valve und Messinstrument).
4. Netzeingangsmodul des Controllers bestehend aus Netzsicherungen, Netzstecker und EMC Filter.
5. Drehschalter zum Setzen der Profibus Adresse.
6. Profibus (Option).
7. Serieller Stecker zur Fernsteuerung.
8. Pumpenstecker.

Rücktafel der Controller Turbo-V 301-AG

## BEDIENUNG

### Einschalten des Controllers

Zum Einschalten des Controllers genügt es, das Netzkabel an die Steckdose anzuschließen.

### Pumpenstart

Zum Starten der Pumpe den Verriegelungseingang bestätigen und die START Taste of der vorderen Konsole des Controllers drücken.

### Pumpenstopp

Zum Stoppen der Pumpe muß die STOPP-Taste an der Fronttafel gedrückt werden.

## WARTUNG

Die Controller der Serie Turbo-V 301 Rack sind wartungsfrei. Eventuell erforderliche Eingriffe müssen von dazu befugtem Fachpersonal ausgeführt werden.

Bei einem Defekt kann der Varian-Reparaturdienst bzw. der "Varian advanced exchange service" in Anspruch genommen werden, der für die Erneuerung defekter Controller sorgt.



**GEFAHR!**

Vor jedem Eingriff am Controller muß der Netzstecker gezogen werden.

Ein Controller muß unter Einhaltung der einschlägigen landesüblichen Vorschriften erfolgen.

## ENTSORGUNG

### Bedeutung des "WEEE" Logos auf den Etiketten.

Das folgende Symbol ist in Übereinstimmung mit der EU-Richtlinie WEEE (Waste Electrical and Electronic Equipment) angebracht.

Dieses Symbol (**nur in den EU-Ländern gültig**) zeigt an, dass das betreffende Produkt nicht zusammen mit Haushaltsmüll entsorgt werden darf sondern einem speziellen Sammelsystem zugeführt werden muss.

Der Endabnehmer sollte daher den Lieferanten des Geräts - d.h. die Muttergesellschaft oder den Wiederverkäufer - kontaktieren, um den Entsorgungsprozess zu starten, nachdem er die Verkaufsbedingungen geprüft hat.

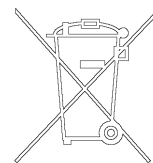

**FEHLERMELDUNGEN**

In einigen Störungsfällen zeigt das Selbstdiagnosesystem des Controllers die in der nachstehenden Tabelle zusammengefaßten Meldungen an.

<b>MELDUNG</b>	<b>BESCHREIBUNG</b>	<b>BEHEBUNG</b>
<b>CHECK CONNECTION TO PUMP</b>	Fehlfunktion der Pumpen-Controller Verbindung. oder Die Temperatur der Pumpe ist unter 0 °C.	Sicherstellen, daß das Verbindungskabel zwischen Pumpe und Controller an beiden Seiten korrekt befestigt ist und keine Unterbrechung vorliegt. Die Pumpe durch zweimalige Betätigung der START-Taste neustarten.
<b>WAITING INTERLOCK</b>	Das Interlock-Signal auf dem Verbinder P1 ist wegen der Kurzschluß-unterbrechung zwischen Pin 3 und Pin 8 des Verbinders K1 oder wegen der Öffnung des externen Interlock-Signals aktiv.	Den Kurzschluß zwischen Pin 3 und Pin 8 des Verbinders J1 rücksetzen oder das externe Interlock-Signal schließen.
<b>PUMP OVERTEMP.</b>	Die Temperatur des oberen Lagers bzw. der Pumpe hat 60 °C überschritten.	Warten bis die Temperatur unter den Schwellenwert gesunken ist. Die Pumpe durch zweimalige Betätigung der START-Taste neustarten.
<b>CONTROLLER OVERTEMP.</b>	Die Temperatur des Controller hat 70 °C überschritten. oder Die Temperatur des Controllerkühlkörpers ist über 60 °C.	Warten bis die Temperatur unter den Schwellenwert gesunken ist. Die Pumpe durch zweimalige Betätigung der START-Taste neustarten.
<b>TOO HIGH LOAD</b>	Die Pumpen ist stromaufnahme größer als die vorgesehene.	Sicherstellen, daß der Pumpenrotor ungehindert drehen kann. Die Pumpe durch zweimalige Betätigung der START-Taste neustarten.
<b>SHORT CIRCUIT</b>	Während des Normalbetriebs (nach der Startphase) erfolgt ein Kurzschluß der Ausgangsverbindung.	Die Verbindung zwischen Pumpe und Controller prüfen. Die Pumpe durch zweimalige Betätigung der START-Taste neustarten.
<b>SYSTEM OVERRIDE</b>	Die Pumpe wurde durch ein von einem entfernten Kontakt kommendes Notsignal gestoppt.	Das Netzkabel des Controllers ausstecken und die Störungsursache beheben. Das Netzkabel wieder anschließen und die Pumpe durch zweimalige Betätigung der START-Taste neustarten.
<b>OVERVOLTAGE</b>	Defekt im Versorgungsbereich des Controllers bzw. der Controller hat ein falsches Signal erhalten	Die Pumpe durch zweimalige Betätigung der START-Taste neustarten. Erscheint die Meldung wieder sollte der Varian-Wartungs-dienst gerufen werden.
<b>POWER FAIL</b>	Defekt im Pumpenstromkreis des Controllers.	Varian für Wartung kontaktieren.

**INDICATIONS GENERALES**

Cet appareillage a été conçu en vue d'une utilisation professionnelle. Il est conseillé à l'utilisateur de lire attentivement cette notice d'instructions ainsi que toute autre indication supplémentaire fournie par Varian, avant l'utilisation de l'appareil. Varian décline par conséquent toute responsabilité en cas d'inobservation totale ou partielle des instructions données, d'utilisation incorrecte de la part d'un personnel non formé, d'opérations non autorisées ou d'un emploi contraire aux réglementations nationales spécifiques. Les contrôleurs de la série Turbo-V 301 Rack sont des convertisseurs de fréquence, contrôlés par un microprocesseur, réalisés avec des éléments à l'état solide et ayant des capacités d'autodiagnostic et d'autoprotection.

Caractéristiques du contrôleur:

- Caractère opérationnel de front /à distance / sériel
- Pilotage à 24 Vdc du ventilateur de refroidissement pompe
- Pilotage vent valve
- Lecture vitesse pompe suite à la commande d'arrêt (lecture vitesse d'arrêt)
- Lecture de la pression
- Interface Profibus (facultatif)
- Attribution automatique tension d'entrée.

Les paragraphes suivants donnent toutes les indications nécessaires à garantir la sécurité de l'opérateur pendant l'utilisation de l'appareillage. Des renseignements plus détaillés se trouvent dans l'appendice "Technical Information".

**Cette notice utilise les signes conventionnels suivants:**



Les messages de danger attirent l'attention de l'opérateur sur une procédure ou une manoeuvre spéciale qui, si elle n'est pas effectuée correctement, risque de provoquer de graves lésions.



Les message d'attention apparaissent avant certaines procédures qui, si elles ne sont pas observées, pourraient endommager sérieusement l'appareillage.

**NOTE**

*Les notes contiennent des renseignements importants, isolés du texte.*

**EMMAGASINAGE**

Pendant le transport et l'emmagasinement des contrôleurs, il faudra veiller à respecter les conditions environnementales suivantes:

- Température: de - 20 °C à + 70 °C
- Humidité relative: 0 - 95% (non condensante).

**PREPARATION POUR L'INSTALLATION**

Le contrôleur est fourni dans un emballage de protection spécial; si l'on constate des marques de dommages pouvant s'être produits pendant le transport, contacter aussitôt le bureau de vente local. Pendant l'opération d'ouverture de l'emballage, veiller tout particulièrement à ne pas laisser tomber le contrôleur et à ne lui faire subir aucun choc. Ne pas jeter l'emballage dans la nature. Le matériel est entièrement recyclable et il est conforme aux directives CEE 83/399 en matière de protection de l'environnement.

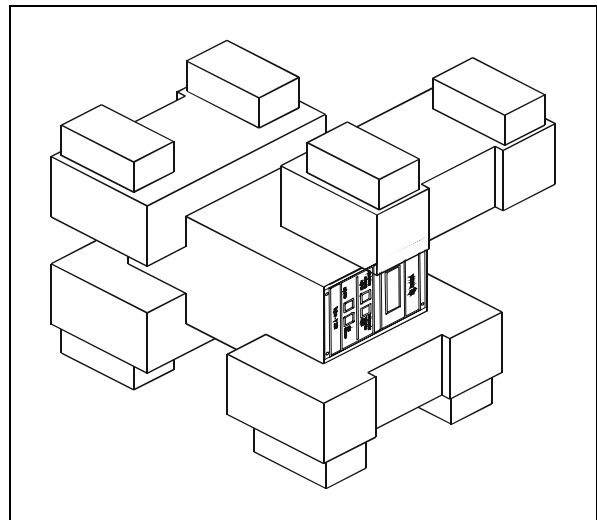

*Emballage du Contrôleur*

## INSTALLATION



**DANGER!**

Le contrôleur doit être alimenté au moyen d'un câble d'alimentation à trois fils (voir tableau des pièces que l'on peut commander) avec une fiche du type approuvé au niveau international en vue de la sécurité de l'utilisateur. Utiliser toujours ce câble d'alimentation et introduire la fiche dans une prise pourvue d'un branchement au sol approprié à la masse, afin d'éviter toute décharge électrique et de respecter les spécifications CE. A l'intérieur du contrôleur se développent de hautes tensions qui peuvent causer de graves dommages, voire la mort. Avant d'effectuer toute opération d'installation ou d'entretien du contrôleur, le débrancher de la prise d'alimentation.

### NOTE

Le contrôleur peut être installé sur un plateau d'appui ou à l'intérieur d'un rack prévu à cet effet. Il est en tout cas nécessaire que l'air de refroidissement puisse circuler librement à l'intérieur de l'appareil. Ne pas installer et/ou utiliser le contrôleur dans des milieux exposés à des agents atmosphériques (pluie, gel, neige), à des poussières, à des gaz de combat ainsi que dans des milieux explosifs ou à risque élevé d'incendie.

Pendant le fonctionnement, il est nécessaire de respecter les conditions environnementales suivantes:

- Température: de 5 °C à + 45 °C
- Humidité relative: 0 - 95% (non condensante).

Pour les autres connexions et pour l'installation des accessoires en option, voir la section "Technical Information".

## UTILISATION

Dans ce paragraphe, on indique les principales procédures opérationnelles. Pour tous autres détails et pour les procédures concernant des connexions ou des éléments en option, se reporter au paragraphe "Use" de l'appendice "Technical Information". Avant d'utiliser le contrôleur, effectuer toutes les connexions électriques et pneumatiques et se référer à la notice de la pompe connectée.



**DANGER!**

Pour éviter tous dommages aux personnes et à l'appareil, si la pompe est placée sur un plateau d'appui s'assurer que ce dernier est stable. Ne jamais faire fonctionner la pompe si la bride d'entrée n'est pas connectée au système ou n'est pas fermée à l'aide de la bride de fermeture.

### NOTE

Laisser le connecteur de réenclenchement J1 connecté à sa barrette s'il n'est procédé à aucune connexion extérieure. La pompe à pré-vide et la pompe Turbo-V peuvent être mises en marche simultanément.

## Commandes, Indicateurs et Connecteurs

On présente ci-dessous le tableau avant et le tableau arrière du Contrôleur. Pour de plus amples détails, se reporter à la section "Technical Information".

### Description du Tableau avant

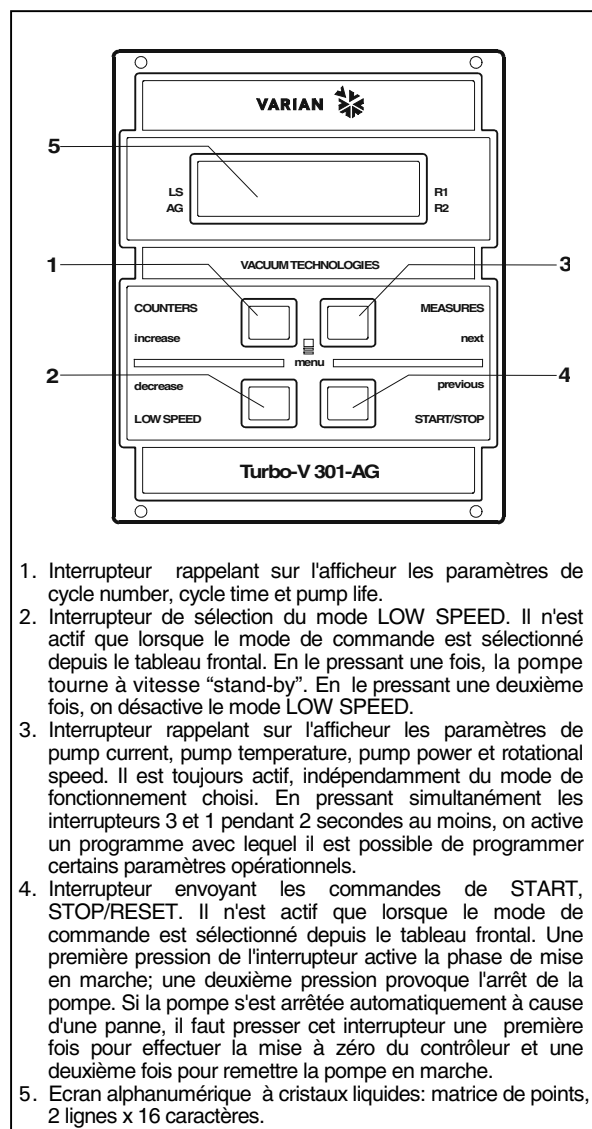

1. Interrupteur rappelant sur l'afficheur les paramètres de cycle number, cycle time et pump life.
2. Interrupteur de sélection du mode LOW SPEED. Il n'est actif que lorsque le mode de commande est sélectionné depuis le tableau frontal. En le pressant une fois, la pompe tourne à vitesse "stand-by". En le pressant une deuxième fois, on désactive le mode LOW SPEED.
3. Interrupteur rappelant sur l'afficheur les paramètres de pump current, pump temperature, pump power et rotational speed. Il est toujours actif, indépendamment du mode de fonctionnement choisi. En pressant simultanément les interrupteurs 3 et 1 pendant 2 secondes au moins, on active un programme avec lequel il est possible de programmer certains paramètres opérationnels.
4. Interrupteur envoyant les commandes de START, STOP/RESET. Il n'est actif que lorsque le mode de commande est sélectionné depuis le tableau frontal. Une première pression de l'interrupteur active la phase de mise en marche; une deuxième pression provoque l'arrêt de la pompe. Si la pompe s'est arrêtée automatiquement à cause d'une panne, il faut presser cet interrupteur une première fois pour effectuer la mise à zéro du contrôleur et une deuxième fois pour remettre la pompe en marche.
5. Ecran alphanumérique à cristaux liquides: matrice de points, 2 lignes x 16 caractères.

Tableau avant du Contrôleur Turbo-V 301-AG



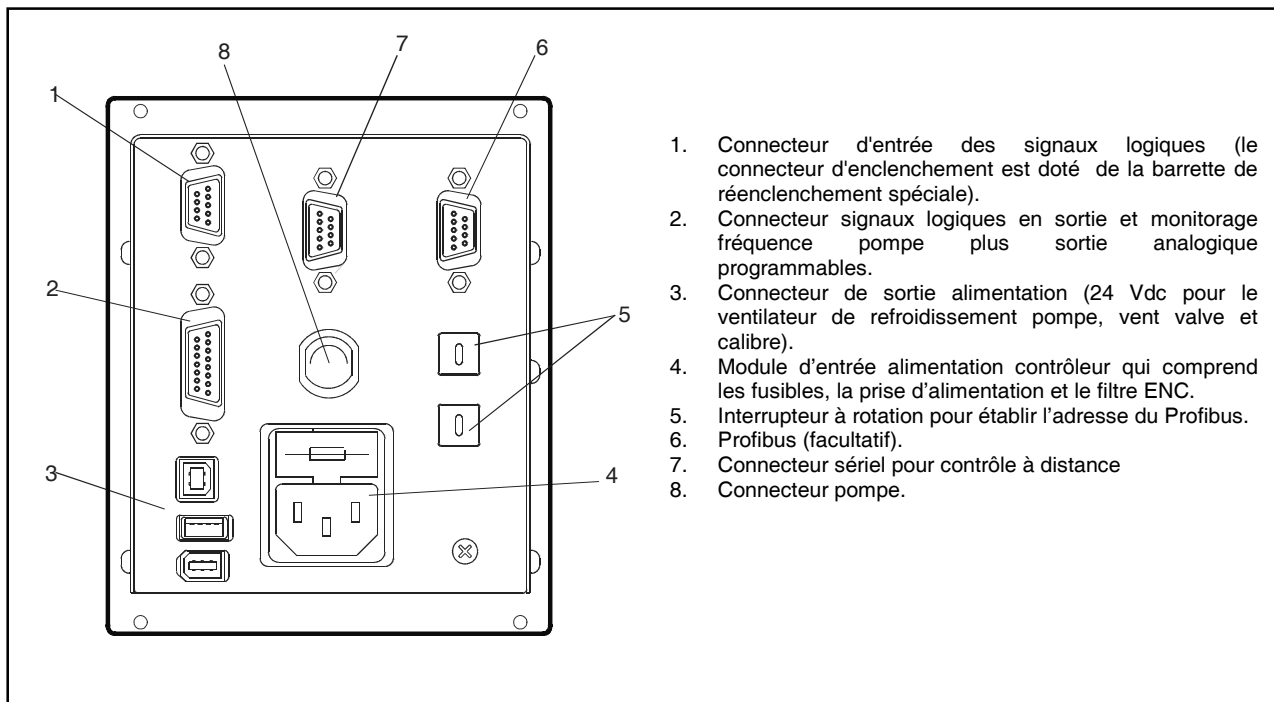

1. Connecteur d'entrée des signaux logiques (le connecteur d'enclenchement est doté de la barrette de réenclenchement spéciale).
2. Connecteur signaux logiques en sortie et monitoring fréquence pompe plus sortie analogique programmables.
3. Connecteur de sortie alimentation (24 Vdc pour le ventilateur de refroidissement pompe, vent valve et calibre).
4. Module d'entrée alimentation contrôleur qui comprend les fusibles, la prise d'alimentation et le filtre ENC.
5. Interrupteur à rotation pour établir l'adresse du Profibus.
6. Profibus (facultatif).
7. Connecteur sériel pour contrôle à distance
8. Connecteur pompe.

Tableau arrière du Contrôleur Turbo-V 301-AG

**PROCEDURES D'UTILISATION**

**Allumage du Contrôleur**

Pour allumer le contrôleur, il suffit d'introduire le câble d'alimentation dans la prise du réseau.

**Mise en marche de la Pompe**

Pour faire démarrer la pompe il faut habiliter l'entrée de interlock et appuyer sur la touche START du panneau avant.

**Arrêt de la Pompe**

Pour arrêter la pompe, presser l'interrupteur STOP du tableau avant.

**ENTRETIEN**

Les contrôleurs de la série Turbo-V 301 Rack n'exigent aucun entretien. Toute opération doit être effectuée par un personnel agréé.

En cas de panne, il est possible de s'adresser au Service de réparation Varian ou bien au "Varian advance exchange service" qui permet d'obtenir un contrôleur régénéré à la place du contrôleur détraqué.

**MISE AU REBUT**

**Signification du logo "WEEE" figurant sur les étiquettes.**

Le symbole ci-dessous est appliqué conformément à la directive CE nommée "WEEE".

Ce symbole (**uniquement valide pour les pays de la Communauté européenne**) indique que le produit sur lequel il est appliqué NE doit PAS être mis au rebut avec les ordures ménagères ou les déchets industriels ordinaires, mais passer par un système de collecte sélective.

Après avoir vérifié les termes et conditions du contrat de vente, l'utilisateur final est donc prié de contacter le fournisseur du dispositif, maison mère ou revendeur, pour mettre en œuvre le processus de collecte et mise au rebut.

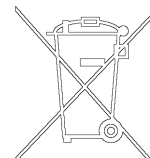

**DANGER!**

Avant d'effectuer toute opération sur le contrôleur, débrancher le câble d'alimentation.

En cas de mise au rebut du contrôleur, procéder à son élimination conformément aux réglementations nationales en la matière.

**MESSAGES D'ERREUR**

Dans certains cas de panne, l'ensemble de circuits d'autodiagnostic du contrôleur présente certains messages d'erreur indiqués dans le tableau ci-dessous.

MESSAGE	DESCRIPTION	INTERVENTION
<b>CHECK CONNECTION TO PUMP</b>	Dysfonctionnement de la connexion entre la pompe et le contrôleur. Ou bien La pompe a une température inférieure à 0 °C.	S'assurer que le câble de connexion entre la pompe et le contrôleur est bien fixé aux deux extrémités et qu'il n'est pas coupé. Presser deux fois l'interrupteur START pour réactiver la pompe.
<b>WAITING INTERLOCK</b>	Le signal d'interlock situé sur le connecteur P1 est actif à cause de la coupure du court-circuit entre le pin 3 et le pin 8 du connecteur J1 ou à cause de l'ouverture du signal d'interlock extérieur.	Rétablir le court-circuit entre le pin 3 et le pin 8 du connecteur J1 ou fermer le signal d'interlock extérieur.
<b>PUMP OVERTEMP.</b>	La température du palier supérieur ou de la a dépassé 60 °C.	Attendre que la température retourne au-dessous du seuil. Presser deux fois l'interrupteur START pour remettre la pompe en marche.
<b>CONTROLLER OVERTEMP.</b>	La température du contrôleur a dépassé 70 °C. Ou bien La température du radiateur du contrôleur est supérieure à 60 °C.	Attendre que la température retourne au-dessous du seuil. Presser deux fois l'interrupteur START pour remettre la pompe en marche.
<b>TOO HIGH LOAD</b>	Pendant le fonctionnement normal (après la phase de mise en marche), le courant absorbé par la pompe est plus grand que celui qui a été programmé.	S'assurer que le rotor de la pompe a la possibilité de tourner librement. Presser deux fois l'interrupteur START pour remettre la pompe en marche.
<b>SHORT CIRCUIT</b>	Pendant le fonctionnement normal (après la phase de mise en marche), la connexion de sortie est en court-circuit.	Vérifier les connexions entre la pompe et le contrôleur. Presser deux fois l'interrupteur START pour remettre la pompe en marche.
<b>SYSTEM OVERRIDE</b>	La pompe a été arrêtée par un signal d'alerte provenant d'un contact éloigné.	Débrancher le câble d'alimentation du contrôleur et corriger la cause de l'alerte. Reconnecter le câble d'alimentation et presser deux fois l'interrupteur START pour remettre la pompe en marche.
<b>OVERVOLTAGE</b>	Il s'est produit une panne de la section d'alimentation du contrôleur, ou bien le contrôleur a reçu un faux signal.	Presser deux fois l'interrupteur START pour remettre la pompe en marche. Si le message se présente à nouveau, s'adresser à Varian pour l'entretien.
<b>POWER FAIL</b>	Panne dans la section d'alimentation de la pompe, du contrôleur.	S'adresser à Varian pour Maintenance.

**INFORMACIÓN GENERAL**

Este equipo se ha concebido para un uso profesional. El usuario deberá leer atentamente el presente manual de instrucciones y cualquier otra información suplementaria facilitada por Varian antes de utilizar el equipo. Varian se considera libre de cualquier responsabilidad debida al incumplimiento total o parcial de las instrucciones, al uso poco apropiado por parte de personal sin formación, a las operaciones no autorizadas o al uso que no cumpla con las normas nacionales específicas. Los controlers de la serie Turbo-V 301 Rack son convertidores de frecuencia, controlados por un microprocesador, realizados con componentes en estado sólido y con capacidad de autodiagnos y autoprotección.

Características del controler:

- Operatividad frontal / remoto / serial
- Pilotaje de 24 Vdc del ventilador de refrigeración bomba
- Pilotaje vent valve
- Lectura velocidad bomba después de activación mando de parada (lectura velocidad de parada)
- Lectura de la presión
- Interfaz Profibus (opcional)
- Configuración automática tensión de entrada.

En los apartados siguientes se facilita toda la información necesaria para garantizar la seguridad del operador durante el uso del equipo. Una información más detallada se facilita en el Suplemento "Technical Information".

**Este manual utiliza los símbolos convencionales siguientes:**



Los mensajes de peligro atraen la atención del operador sobre un procedimiento o una operación específica que, al no realizarse correctamente, podría provocar graves lesiones personales.



Los mensajes de atención se visualizan antes de procedimientos que, al no respetarse, podrían provocar daños al equipo.

**NOTA**

*Las notas contienen información importante extraída del texto.*

**ALMACENAMIENTO**

Durante el transporte y el almacenamiento de los controlers se deberá cumplir con las condiciones ambientales siguientes:

- temperatura: de -20 °C a +70 °C
- humedad relativa: 0 - 95% (no condensadora)

**PREPARACIÓN PARA LA INSTALACIÓN**

El controler se suministra en un embalaje de protección especial; si se observan señales de daños, que podrían haberse producido durante el transporte, ponerse en contacto con la oficina de venta más cercana. Durante la operación de desembalaje, prestar una atención especial a no dejar caer el controler y evitarle golpes. No dispersar el embalaje en el medio ambiente. El material es totalmente reciclable y cumple con la directiva CEE 85/399 para la preservación del medio ambiente.

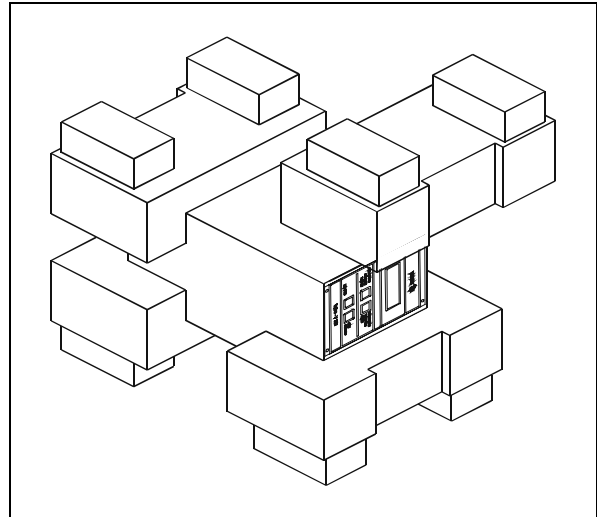

*Embalaje de los Controlers*

**INSTALACIÓN**



**¡PELIGRO!**

El controler debe ser alimentado mediante un cable de tres hilos (ver tabla de los componentes que pueden ser ordenados) con una clavija del tipo aprobado a nivel internacional con la finalidad de respetar las normas correspondientes a la seguridad del usuario. Utilizar siempre este cable de alimentación e introducir la clavija en un enchufe con una conexión de masa adecuada para evitar descargas eléctricas. y respetar las especificaciones CE. Dentro del controler se desarrollan altas tensiones que pueden causar graves daños o la muerte. Antes de efectuar cualquier operación de instalación o mantenimiento del controler desconectarlo del enchufe de alimentación.

**NOTA**

*El controler puede instalarse en una mesa o dentro de un rack específico. En cualquier caso, es necesario que el aire de refrigeración pueda circular libremente alrededor del aparato. No instalar y/o utilizar el controler en ambientes expuestos a agentes atmosféricos (lluvia, hielo y nieve), polvos, gases agresivos, en ambientes explosivos o con alto riesgo de incendio.*

Durante el funcionamiento es necesario que se respeten las condiciones ambientales siguientes:

- temperatura: de 5 °C a +45 °C
- humedad relativa: 0 - 95% (no condensadora).

Para otras conexiones y la instalación de los accesorios opcionales, véase la sección "Technical Information".

**USO**

En este apartado se citan los procedimientos operativos principales. Para más detalles y para procedimientos que impliquen conexiones u opcionales especiales, les remitimos al apartado "Use" del anexo "Technical Information".

Antes de usar el controler efectuar todas las conexiones eléctricas y neumáticas y consultar el manual de la bomba conectada.



**¡PELIGRO!**

Para evitar lesiones a las personas y al aparato, si la bomba está apoyada sobre una mesa cerciorarse que es estable. No poner en marcha nunca la bomba si la brida de entrada no está conectada al sistema o no está cerrada con la brida de cierre.

**NOTA**

*El conector de cierre J1 ha de dejarse conectado con su conector puente si no se efectúa ninguna conexión exterior. La bomba pre-vacío y la bomba Turbo-V pueden encenderse simultáneamente.*

**Mandos, indicadores y conectores**

A continuación se ha ilustrado el panel frontal y el panel trasero del controler. Para más detalles consultar la sección "Technical Information".

**Descripción del panel frontal**

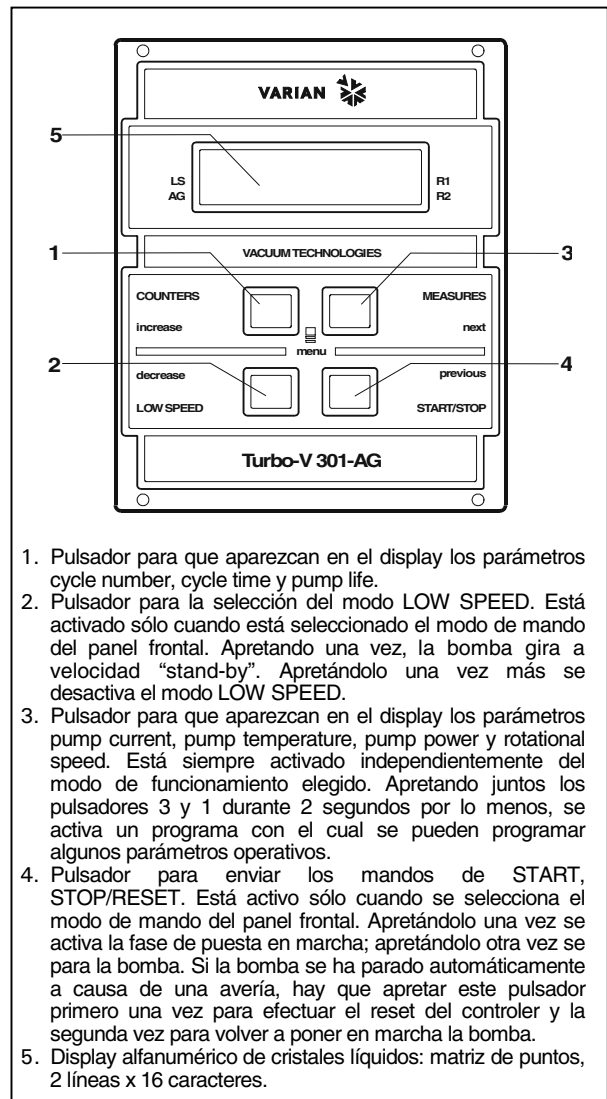

1. Pulsador para que aparezcan en el display los parámetros cycle number, cycle time y pump life.
2. Pulsador para la selección del modo LOW SPEED. Está activado sólo cuando está seleccionado el modo de mando del panel frontal. Apretando una vez, la bomba gira a velocidad "stand-by". Apretándolo una vez más se desactiva el modo LOW SPEED.
3. Pulsador para que aparezcan en el display los parámetros pump current, pump temperature, pump power y rotational speed. Está siempre activado independientemente del modo de funcionamiento elegido. Apretando juntos los pulsadores 3 y 1 durante 2 segundos por lo menos, se activa un programa con el cual se pueden programar algunos parámetros operativos.
4. Pulsador para enviar los mandos de START, STOP/RESET. Está activo sólo cuando se selecciona el modo de mando del panel frontal. Apretándolo una vez se activa la fase de puesta en marcha; apretándolo otra vez se para la bomba. Si la bomba se ha parado automáticamente a causa de una avería, hay que apretar este pulsador primero una vez para efectuar el reset del controler y la segunda vez para volver a poner en marcha la bomba.
5. Display alfanumérico de cristales líquidos: matriz de puntos, 2 líneas x 16 caracteres.

*Panel frontal del Controller Turbo-V 301-AG*

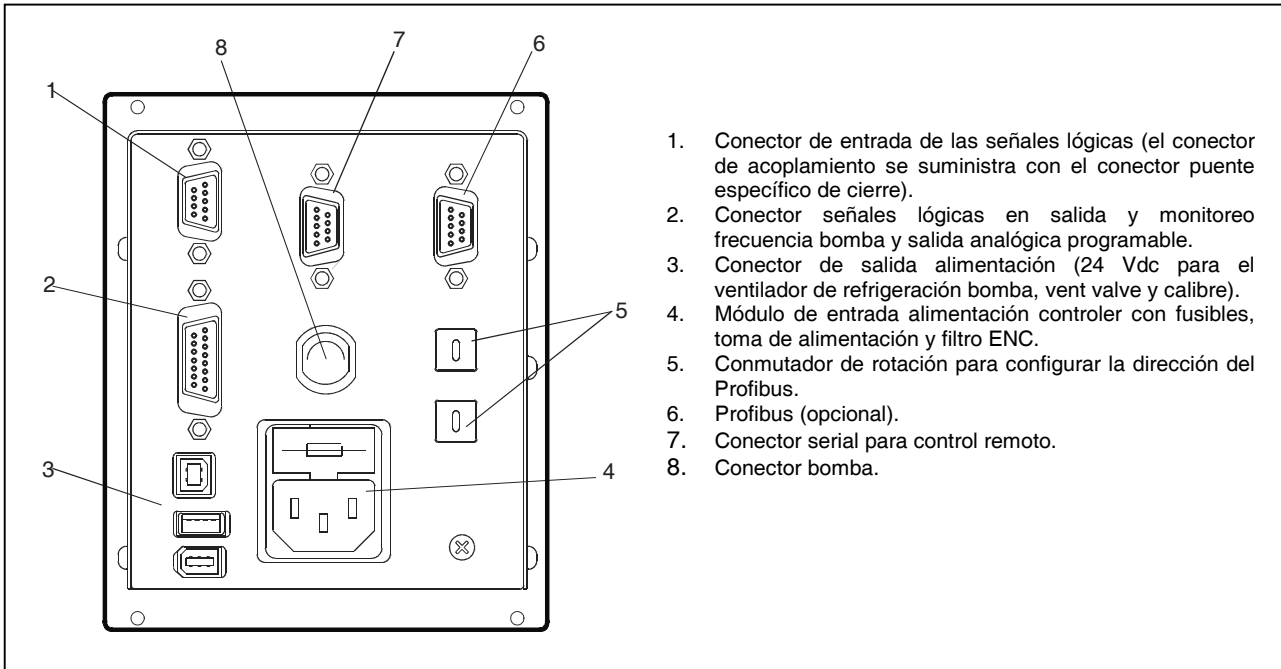

1. Conector de entrada de las señales lógicas (el conector de acoplamiento se suministra con el conector puente específico de cierre).
2. Conector señales lógicas en salida y monitoreo frecuencia bomba y salida analógica programable.
3. Conector de salida alimentación (24 Vdc para el ventilador de refrigeración bomba, vent valve y calibre).
4. Módulo de entrada alimentación controler con fusibles, toma de alimentación y filtro ENC.
5. Conmutador de rotación para configurar la dirección del Profibus.
6. Profibus (opcional).
7. Conector serial para control remoto.
8. Conector bomba.

Panel trasero del controler Turbo-V 301-AG

**PROCEDIMIENTOS DE USO**

**Encendido del controler**

Para encender el controler es suficiente introducir el cable de alimentación en la toma de red.

**Puesta en marcha de la Bomba**

Para activar la bomba es necesario habilitar la entrada de interlock y pulsar el botón START situado en el panel frontal.

**Parada de la Bomba**

Para detener la bomba hay que apretar el pulsador STOP del panel frontal.

**MANTENIMIENTO**

Los controlers de la serie Turbo-V 301 Rack no necesitan ningún mantenimiento. Cualquier operación ha de ser efectuada por personal autorizado. En caso de avería es posible utilizar el servicio de reparación Varian o del "Varian advance exchange service", que permite obtener un controler regenerado en vez del averiado.

**ELIMINACIÓN**

**Significado del logotipo "WEEE" presente en las etiquetas.**

El símbolo que se indica a continuación, es aplicado en observancia de la directiva CE denominada "WEEE". Este símbolo (**válido sólo para los países miembros de la Comunidad Europea**) indica que el producto sobre el cual ha sido aplicado, NO debe ser eliminado junto con los residuos comunes sean éstos domésticos o industriales, y que, por el contrario, deberá ser sometido a un procedimiento de recogida diferenciada..

Por lo tanto, se invita al usuario final, a ponerse en contacto con el proveedor del dispositivo, tanto si éste es la casa fabricante o un distribuidor, para poder proveer a la recogida y eliminación del producto, después de haber efectuado una verificación de los términos y condiciones contractuales de venta.

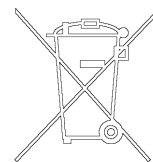

**¡PELIGRO!**

Antes de efectuar cualquier operación en el controler desenchufar el cable de alimentación.

En caso de que un controler se tenga que desguazar, efectuar su eliminación respetando las normas nacionales específicas.

**MENSAJES DE ERROR**

En algunos casos de avería los circuitos de autodiagnos del controler presenta algunos mensajes de error detallados en la tabla siguiente.

<b>MENSAJE</b>	<b>DESCRIPCIÓN</b>	<b>ACCIÓN CORRECTIVA</b>
<b>CHECK CONNECTION TO PUMP</b>	Mal funcionamiento en la conexión entre la bomba y el Controler. O bien La bomba tiene una temperatura inferior a 0 °C.	Comprobar que el cable de conexión entra en la bomba y el controler está bien fijado por ambos extremos y no está interrumpido. Apretar dos veces el pulsador START para volver a poner en marcha la bomba.
<b>WAITING INTERLOCK</b>	Está activa la señal de interlock presente en el conector P1 a causa de la interrupción del cortocircuito entre el pin 3 y el pin 8 del conector J1, o a causa de la apertura de la señal de interlock externo.	Eliminar el cortocircuito entre el pin 3 y el pin 8 del conector J1, o cerrar la señal de interlock exterior.
<b>PUMP OVERTEMP.</b>	La temperatura del rodamiento superior o de la bomba ha superado los 60 °C.	Esperar a que la temperatura vuelva por debajo del umbral. Apretar dos veces el pulsador START para volver a poner en marcha la bomba.
<b>CONTROLLER OVERTEMP.</b>	La temperatura del controler ha superado los 70 °C. O bien La temperatura del radiador del controler es superior a 60 °C.	Esperar a que la temperatura vuelva por debajo del umbral. Apretar dos veces el pulsador START para volver a poner en marcha la bomba.
<b>TOO HIGH LOAD</b>	La corriente absorbida por la bomba es superior a la programada.	Comprobar que el rotor de la bomba tiene la posibilidad de girar libremente. Apretar dos veces el pulsador START para volver a poner en marcha la bomba.
<b>SHORT CIRCUIT</b>	Durante el funcionamiento normal (tras la fase de puesta en marcha) la conexión de salida está en cortocircuito.	Comprobar las conexiones entre la bomba y el controler. Apretar dos veces el pulsador START para volver a poner en marcha la bomba.
<b>SYSTEM OVERRIDE</b>	La bomba ha sido parada por una señal de emergencia procedente de un contacto remoto.	Desenchufar el cable de alimentación del controler y corregir la causa de la emergencia. Volver a conectar el cable de alimentación y apretar dos veces el pulsador START para volver a poner en marcha la bomba.
<b>OVERVOLTAGE</b>	Se ha producido una avería en la sección de alimentación del controler o el controler ha recibido una señal espurio.	Apretar dos veces el pulsador START para volver a poner en marcha la bomba. Si el mensaje se vuelve a presentar dirigirse a Varian para el mantenimiento.
<b>POWER FAIL</b>	Avería en la sección de alimentación de la bomba, del controler.	Ponerse en contacto con Varian para el Mantenimiento.

## INFORMAÇÕES GERAIS

Esta aparelhagem destina-se ao uso profissional. O utilizador deve ler atentamente o presente manual de instruções e todas as informações adicionais fornecidas pela Varian antes de utilizar a aparelhagem. A Varian não se responsabiliza pela inobservância total ou parcial das instruções, pelo uso indevido por parte de pessoas não treinadas, por operações não autorizadas ou pelo uso contrário às normas nacionais específicas.

Os controllers da série Turbo-V 301 Rack são conversores de frequência, controlados por um microprocessador, realizados com componentes em estado sólido e com capacidade de autodiagnóstico e autoprotecção.

Características do controller:

- Operatividade frontal / remota / serial
- Pilotagem em 24 Vdc da ventoinha de resfriamento bomba
- Pilotagem vent valve
- Leitura velocidade bomba seguindo ao comando de paragem (leitura velocidade de paragem)
- Leitura da pressão
- Interface Profibus (opcional)
- Impostação automática tensão de entrada.

Nos parágrafos seguintes estão descritas todas as informações necessárias para garantir a segurança do operador durante o uso da aparelhagem. Informações pormenorizadas são fornecidas no apêndice "Technical Information".

**Este manual utiliza as seguintes convenções:**



**PERIGO!**

As mensagens de perigo chamam a atenção do operador para um procedimento ou uma prática específica que, se não efectuada correctamente, pode provocar graves lesões pessoais.



**ATENÇÃO!**

As mensagens de atenção são visualizadas antes de procedimentos que, se não observados, podem causar danos à aparelhagem.

### NOTA

As notas contêm informações importantes destacadas do texto.

## ARMAZENAGEM

Durante o transporte e a armazenagem dos controllers, devem ser satisfeitas as seguintes condições ambientais:

- temperatura: de -20 °C a + 70 °C
- humidade relativa: 0 - 95% (não condensante)

## PREPARAÇÃO PARA A INSTALAÇÃO

O controller é fornecido numa embalagem protectora especial; se apresentarem sinais de danos, que poderiam verificar-se durante o transporte, entrar em contacto com o escritório de vendas local.

Durante a retirada da embalagem, tomar muito cuidado para não deixar cair o controller e para não submetê-lo a choques. Não depositar a embalagem no meio ambiente. O material é completamente reciclável e responde à directrizes CEE 85/399 para a protecção do meio ambiente.

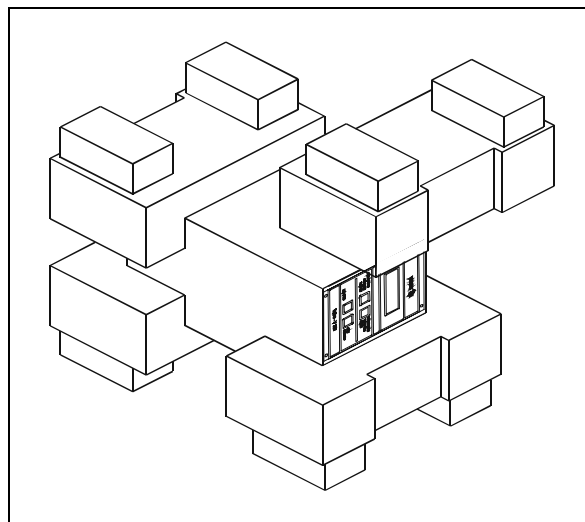

*Embalagem dos controllers*

## INSTALAÇÃO



**PERIGO!**

O controller deve ser alimentado mediante um cabo de alimentação de três fios (ver tabela das partes ordenáveis) com uma tomada de tipo aprovado a nível internacional com a finalidade de segurança do usuário. Utilizar sempre este cabo de alimentação e inserir a tomada com uma adequada ligação de terra para evitar descargas eléctricas e para respeitar as normativas CE. No interior do controller desenvolvem-se altas tensões que podem provocar graves danos ou a morte. Antes de efectuar qualquer operação de instalação ou manutenção do controller, desligar a tomada de alimentação.

### NOTA

O controller pode ser instalado numa mesa ou no interior de um rack específico. Em todo caso é necessário que o ar de refrigeração possa circular livremente ao redor da aparelhagem. Não instalar e/ou utilizar o controller em ambientes expostos a agentes atmosféricos (chuva, gelo, neve), poeiras, gases agressivos ou em ambientes explosivos ou com elevado risco de incêndio.

Durante o funcionamento é necessário que sejam respeitadas as seguintes condições ambientais:

- temperatura: de 5 °C a +45 °C
- humidade relativa: 0 - 95% (não condensante).

Para as outras ligações e a instalação dos acessórios opcionais, ver a secção "Technical Information".

## UTILIZAÇÃO

Neste parágrafo são descritos os principais procedimentos operativos. Para maiores detalhes e para procedimentos que envolvem ligações ou peças opcionais, consultar o parágrafo "Use" do apêndice "Technical Information".

Antes de usar o controller efectuar todas as ligações eléctricas e pneumáticas e consultar o manual da bomba ligada.



**PERIGO!**

Para evitar danos às pessoas e à aparelhagem, caso a bomba esteja apoiada numa mesa, certificar-se que esteja estável. Nunca activar a bomba se o flange de entrada não está ligado ao sistema ou não está fechado com o flange de fecho.

### NOTA

O conector de fecho J1 deve estar ligado com a sua ponte se não é efectuada nenhuma ligação externa. A bomba de pré-vácuo e a bomba Turbo-V podem ser ligadas simultaneamente.

### Comandos, Indicadores e Conectores

A seguir são ilustrados o painel frontal e posterior do controller. Para maiores detalhes, consultar a secção "Technical Information".

#### Descrição painel frontal

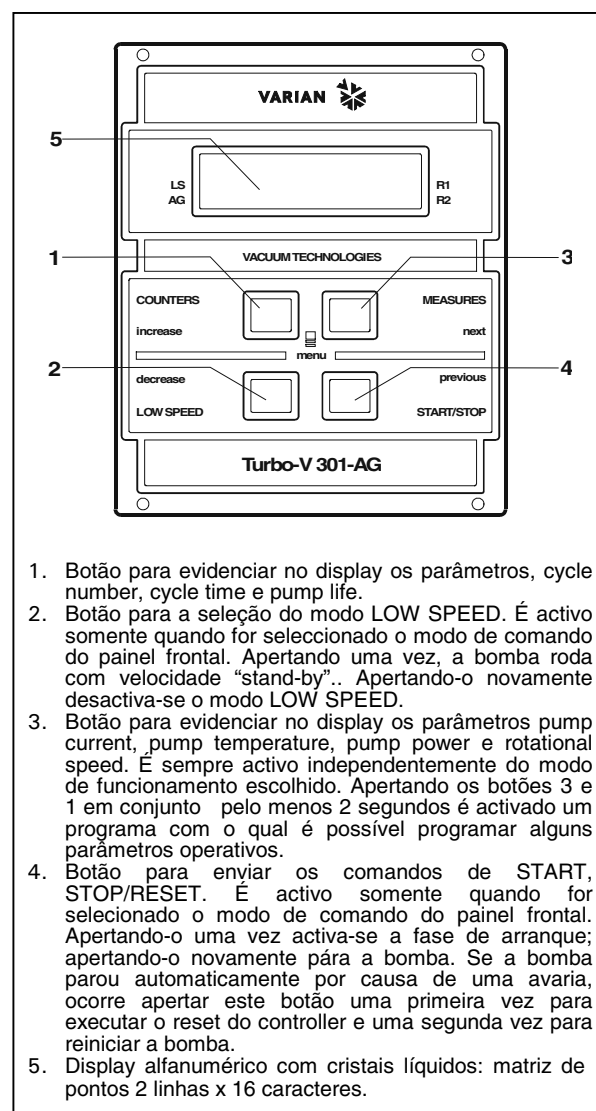

1. Botão para evidenciar no display os parâmetros, cycle number, cycle time e pump life.
2. Botão para a seleção do modo LOW SPEED. É activo somente quando for seleccionado o modo de comando do painel frontal. Apertando uma vez, a bomba roda com velocidade "stand-by". Apertando-o novamente desactiva-se o modo LOW SPEED.
3. Botão para evidenciar no display os parâmetros pump current, pump temperature, pump power e rotational speed. É sempre activo independentemente do modo de funcionamento escolhido. Apertando os botões 3 e 1 em conjunto pelo menos 2 segundos é activado um programa com o qual é possível programar alguns parâmetros operativos.
4. Botão para enviar os comandos de START, STOP/RESET. É activo somente quando for seleccionado o modo de comando do painel frontal. Apertando-o uma vez activa-se a fase de arranque; apertando-o novamente pára a bomba. Se a bomba parou automaticamente por causa de uma avaria, ocorre apertar este botão uma primeira vez para executar o reset do controller e uma segunda vez para reiniciar a bomba.
5. Display alfanumérico com cristais líquidos: matriz de pontos 2 linhas x 16 caracteres.

Painel frontal do Controller Turbo-V 301-AG



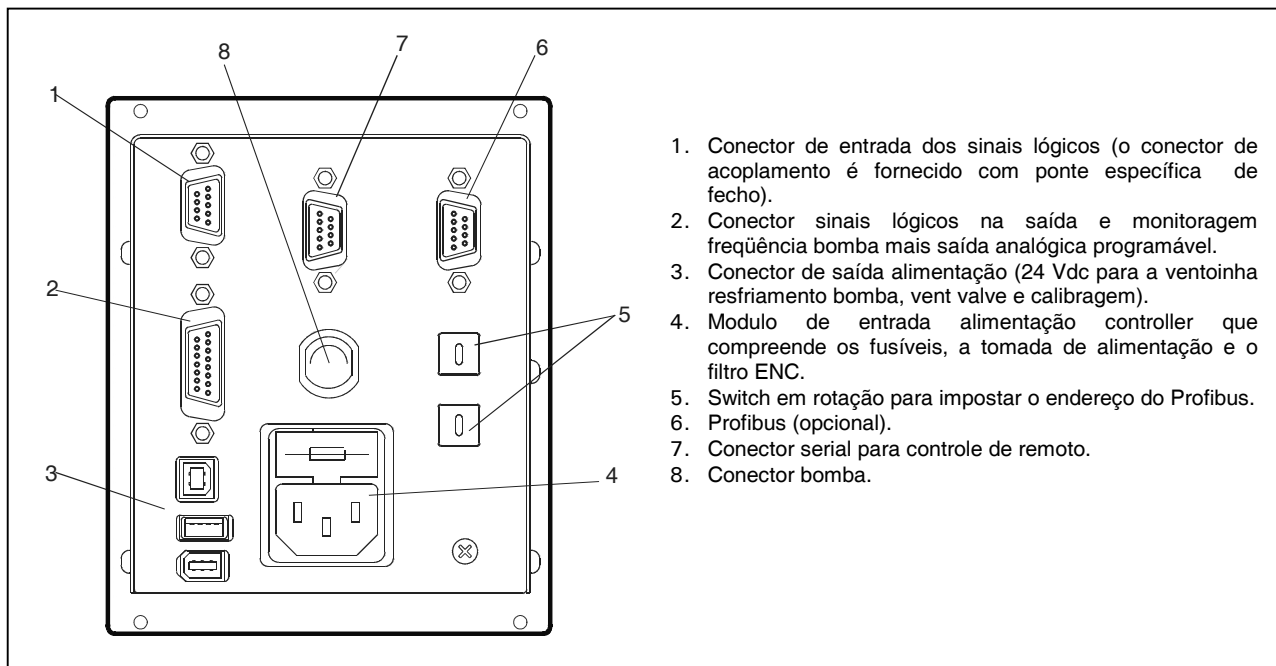

*Painel posterior dos Controllers Turbo-V 301-AG*

**PROCEDIMENTOS DE USO**

**Acendimento do Controller**

Para ligar o controller é suficiente inserir o cabo de alimentação na tomada de rede.

**Activação da bomba**

Para ligar a bomba ocorre habilitar a entrada de interlock e apertar o botão START do painel frontal.

**Paragem da bomba**

Para parar a bomba é necessário premer o botão STOP do painel frontal.

**MANUTENÇÃO**

Os controllers da série Turbo-V 301 Rack não requerem qualquer manutenção. Todas as operações devem ser efectuadas por pessoal autorizado.

Em caso de defeito é possível utilizar o serviço de reparação Varian ou o "Varian advanced exchange service", que permite obter um controller regenerado que substitua o controller com defeito.



**PERIGO!**

Antes de efectuar qualquer operação no controller, desligar o conector de alimentação.

Caso um controller deva ser destruído, proceder à sua eliminação respeitando as normas nacionais específicas.

**ELIMINAÇÃO**

**Significado do logótipo "WEEE" presente nos rótulos.**

O símbolo abaixo indicado é aplicado de acordo com a directiva CE denominada "WEEE". Este símbolo (**válido apenas para os países da Comunidade Europeia**) indica que o produto no qual está aplicado **NÃO** deve ser eliminado juntamente com os resíduos domésticos ou industriais comuns, mas deve ser dirigido a um sistema de recolha diferenciada. Portanto, convidamos o utilizador final a contactar o fornecedor do dispositivo, seja este o fabricante ou um revendedor, para encaminhar o processo de recolha e eliminação, após a oportuna verificação dos termos e condições do contrato de venda.

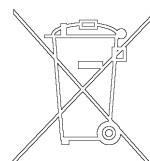

**MENSAGENS DE ERRO**

Em alguns casos de defeitos, os circuitos de autodiagnóstico do controller apresentam mensagens de erro relacionadas na tabela abaixo.

<b>MENSAGEM</b>	<b>DESCRIÇÃO</b>	<b>ACÇÃO CORRECTIVA</b>
<b>CHECK CONNECTION TO PUMP</b>	Mau funcionamento na ligação entre a bomba e o controller. Ou A bomba possui temperatura inferior a 0 °C.	Verificar se o cabo de ligação entre a bomba e o controller está bem fixado em ambas as extremidades e não está interrompido. Premer duas vezes o botão START para reactivar a bomba.
<b>WAITING INTERLOCK</b>	É activado o sinal de interlock existente no conector P1 devido à interrupção do curto circuito entre o pin 3 e o pin 8 do conector J1 ou devido à abertura do sinal de interlock externo.	Restabelecer o curto circuito entre o pin 3 e o pin 8 do conector J1 ou fechar o sinal de interlock externo.
<b>PUMP OVERTEMP.</b>	A temperatura do rolamento superior ou da bomba superou os 60 °C.	Aguardar até que a temperatura volte ao limite estabelecido. Premer duas vezes o botão START para reactivar a bomba.
<b>CONTROLLER OVERTEMP.</b>	A temperatura do controller superou os 70 °C. Ou A temperatura do radiador do controller é superior a 60 °C.	Aguardar até que a temperatura volte ao limite estabelecido. Premer duas vezes o botão START para reactivar a bomba.
<b>TOO HIGH LOAD</b>	Durante o funcionamento normal (após a fase de accionamento) a corrente absorvida pela bomba é maior do que a programada.	Verificar se o rotor da bomba pode rodar livremente. Premer duas vezes o botão START para reactivar a bomba.
<b>SHORT CIRCUIT</b>	Durante o funcionamento normal (após a fase de accionamento) a conexão de saída está em curto circuito.	Verificar as ligações entre a bomba e o controller. Premer duas vezes o botão START para reactivar a bomba.
<b>SYSTEM OVERRIDE</b>	A bomba parou por um sinal de emergência proveniente de um contacto remoto.	Remover o cabo de alimentação do controller e corrigir a causa da emergência. Ligar novamente o cabo de alimentação e premer duas vezes o botão START para reactivar a bomba.
<b>OVERVOLTAGE</b>	Verificou-se um defeito na secção de alimentação do controller, ou o controller recebeu um sinal falso.	Premer duas vezes o botão START para reactivar a bomba. Se a mensagem se reapresentar, dirigir-se à Varian para a manutenção.
<b>POWER FAIL</b>	Avaria na secção de alimentação da bomba, do controller.	Dirigir-se a Varian para Manutenção.

**ALGEMENE INFORMATIE**

Deze apparatuur is bestemd voor beroepsmatig gebruik. De gebruiker wordt verzocht aandachtig deze handleiding en alle overige door Varian verstrekte informatie door te lezen alvorens het apparaat in gebruik te nemen. Varian acht zich niet aansprakelijk voor de gevolgen van het niet of gedeeltelijk in acht nemen van de aanwijzingen, onoordeelkundig gebruik door niet hiervoor opgeleid personeel, reparaties waarvoor geen toestemming is verkregen of gebruik in strijd met de specifieke nationale wetgeving. De controllers van de Turbo-V 301 Rack serie zijn frequentieomzetter die gestuurd worden door een microprocessor, zijn gemaakt van halfgeleider-elementen en zijn in staat om zelfdiagnose en zelfbescherming uit te voeren.

Kenmerken van de controller:

- Bediening frontaal / op afstand / serieel
- Sturing met 24 Vdc van de koelventilator van de pomp
- Sturing vent valve
- Lezen snelheid pomp na stopcommando (lezen stopsnelheid)
- Lezen van de druk
- Interface Profibus (optie)
- Automatische instelling ingangsspanning.

In de volgende paragrafen is alle informatie vermeld om de veiligheid van de operator tijdens het gebruik van de apparatuur te verzekeren. Gedetailleerde informatie is te vinden in de bijlage "Technical information".

**Deze handleiding hanteert de volgende symbolen:**



Bij dit symbool staat tekst die de aandacht van de operator vestigt op een speciale procedure of methode die, indien niet correct uitgevoerd, ernstig lichamelijk letsel kan veroorzaken.



Bij dit symbool staat tekst met procedures die, indien niet opgevolgd, schade aan apparatuur kunnen veroorzaken.

**OPMERKING**

*De opmerkingen bevatten belangrijke informatie die uit de tekst is gelicht.*

**OPSLAG**

Tijdens het transport en de opslag van de controllers moeten de volgende omgevingscondities aanwezig zijn:

- temperatuur: van -20 °C tot +70 °C
- relatieve vochtigheid: 0 - 95% (niet condenserend)

**VOORBEREIDING VOOR INSTALLATIE**

De controller wordt in een speciale beschermende verpakking geleverd; als er schade wordt geconstateerd die tijdens het transport veroorzaakt zou kunnen zijn, meteen contact opnemen met het plaatselijke verkoopkantoor.

Zorg er bij het uitpakken voor dat de controller niet kan vallen of stoten te verduren krijgt.

Laat de verpakking niet ergens buiten achter. Het verpakkingsmateriaal is volledig recyclebaar en voldoet aan de EEG milieurechtlijn 85/399.

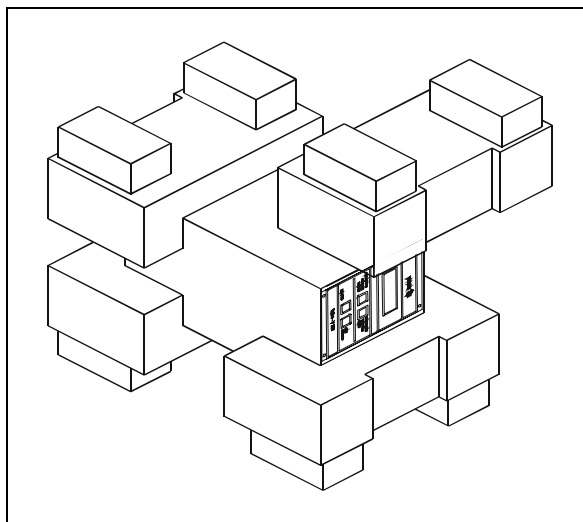

*Verpakking van de controllers*

**INSTALLATIE**



**GEVAAR!**

De controller moet gevoed worden via een voedingskabel met drie draden (zie tabel met bestelbare onderdelen) met een stekker van het internationaal goedgekeurde type om de veiligheid van de gebruiker te waarborgen. Gebruik altijd deze voedingskabel en steek de stekker in een geaarde contactstop om elektrische ontladingen te voorkomen en aan de CE-specificaties te voldoen.

In de controller ontwikkelen zich hoge spanningen die zware beschadigingen of de dood kunnen veroorzaken. Alvorens installatie- of onderhoudswerkzaamheden uit te voeren, de controller van de contactstop afkoppelen.

**OPMERKING**

*De controller kan op een tafel of in een speciaal rack worden geïnstalleerd. In ieder geval moet de koellucht vrij rondom het apparaat kunnen circuleren. De controller mag niet geïnstalleerd en/of gebruikt worden in ruimten die blootgesteld zijn aan de weersomstandigheden (regen, vorst, sneeuw), stof, agressieve gassen, of in ruimten met explosiegevaar of zeer hoog brandgevaar.*

Tijdens de werking moeten de volgende omgevingscondities aanwezig zijn:

- temperatuur: van 5 °C tot +45 °C
- relatieve vochtigheid: 0 - 95% (niet condenserend).

Voor de overige aansluitingen en de installatie van de accessoires wordt verwezen naar het hoofdstuk "Technical Information".

**GEBRUIK**

In deze paragraaf worden de voornaamste bedieningswijzen uitgelegd. Voor meer informatie of procedures die aansluitingen of speciale opties betreffen wordt verwezen naar de paragraaf "Use" van de bijlage "Technical Information".

Breng, alvorens de controller in gebruik te nemen, alle elektrische en pneumatische aansluitingen tot stand en raadpleeg hiervoor de handleiding van de aan te sluiten pomp.



**GEVAAR!**

Indien de pomp op een tafel is geplaatst, controleren of deze stabiel staat om letsel aan personen en schade aan het apparaat te voorkomen. Laat de pomp nooit werken zonder dat de ingangsfens aan het systeem is gekoppeld of de afsluitfens is gesloten.

**OPMERKING**

*De connector J1 moet met zijn jumper aangesloten blijven als geen externe aansluiting tot stand wordt gebracht. De pre-vacuümpomp en de Turbo-V pomp mogen beide gelijktijdig ingeschakeld zijn.*

**Bedieningsorganen, controlelampjes en connectoren van**

Hieronder worden het frontpaneel en het achterpaneel van de controller geïllustreerd. Voor meer informatie wordt verwezen naar het hoofdstuk "Technical Information".

**Beschrijving frontpaneel**

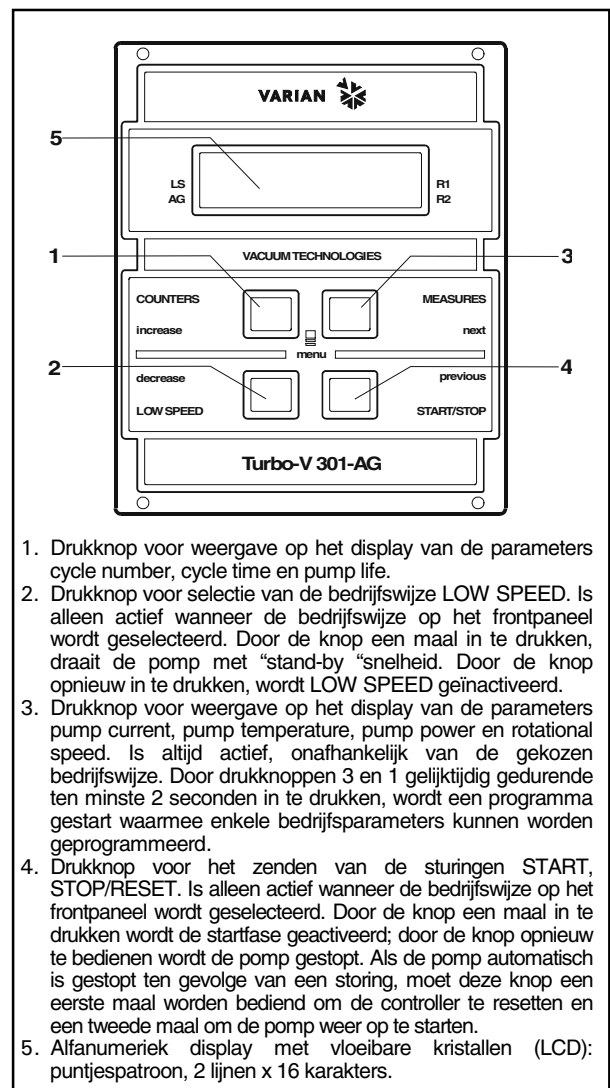

1. Drukknop voor weergave op het display van de parameters cycle number, cycle time en pump life.
2. Drukknop voor selectie van de bedrijfswijze LOW SPEED. Is alleen actief wanneer de bedrijfswijze op het frontpaneel wordt geselecteerd. Door de knop een maal in te drukken, draait de pomp met "stand-by" snelheid. Door de knop opnieuw in te drukken, wordt LOW SPEED geïnactiveerd.
3. Drukknop voor weergave op het display van de parameters pump current, pump temperature, pump power en rotational speed. Is altijd actief, onafhankelijk van de gekozen bedrijfswijze. Door drukknoppen 3 en 1 gelijktijdig gedurende ten minste 2 seconden in te drukken, wordt een programma gestart waarmee enkele bedrijfsparameters kunnen worden geprogrammeerd.
4. Drukknop voor het zenden van de sturingen START, STOP/RESET. Is alleen actief wanneer de bedrijfswijze op het frontpaneel wordt geselecteerd. Door de knop een maal in te drukken wordt de startfase geactiveerd; door de knop opnieuw te bedienen wordt de pomp gestopt. Als de pomp automatisch is gestopt ten gevolge van een storing, moet deze knop een eerste maal worden bediend om de controller te resetten en een tweede maal om de pomp weer op te starten.
5. Alfanumeriek display met vloeibare kristallen (LCD): puntjespatroon, 2 lijnen x 16 karakters.

*Frontpaneel van de Controllers Turbo-V 301-AG*

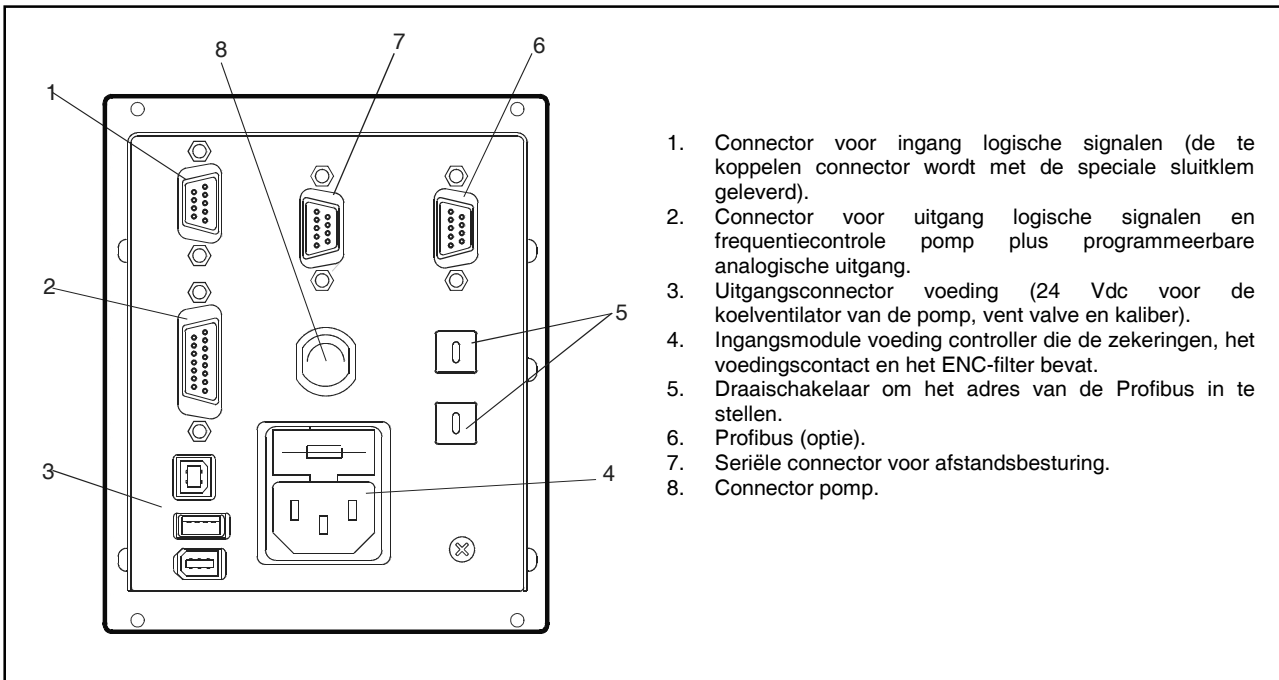

*Achterpaneel van de controllers Turbo-V 301-AG*

1. Connector voor ingang logische signalen (de te koppelen connector wordt met de speciale sluitklem geleverd).
2. Connector voor uitgang logische signalen en frequentiecontrole pomp plus programmeerbare analogische uitgang.
3. Uitgangconnector voeding (24 Vdc voor de koelventilator van de pomp, vent valve en kaliber).
4. Ingangsmodule voeding controller die de zekeringen, het voedingscontact en het ENC-filter bevat.
5. Draaischakelaar om het adres van de Profibus in te stellen.
6. Profibus (optie).
7. Seriele connector voor afstandsbesturing.
8. Connector pomp.

**GEbruIKSPROCEDURES**

***Inschakelen van de controller***

Om de controller in te schakelen, de voedingskabel in de netcontactdoos inbrengen.

***Starten van de pomp***

Om de pomp te starten, de interlock-ingang inschakelen en op de START-knop op het frontpaneel drukken.

***Stoppen van de pomp***

Voor het stoppen van de pomp de STOP-knop op het frontpaneel bedienen.

**ONDERHOUD**

De controllers van de serie Turbo-V 301 zijn onderhoudsvrij. Eventuele werkzaamheden moeten door bevoegd personeel worden uitgevoerd.

In geval van storing is het mogelijk om de reparatiedienst van Varian of de "Varian advanced exchange service" in te schakelen: zo krijgt men een ruilcontroller ter vervanging van de defecte controller.

**AFVALVERWERKING**

**Betekenis van het logo "WEEE" op de etiketten.** Het onderstaande symbool wordt aangebracht in overeenstemming met de EG-richtlijn "WEEE". Dit symbool (**alleen geldig voor de landen van de Europese Gemeenschap**) geeft aan dat het product waarop het is aangebracht, NIET mag worden afgevoerd samen met normaal huisvuil of industrieel afval, maar gescheiden moet worden ingezameld. De eindgebruiker wordt dus verzocht contact op te nemen met de leverancier van het apparaat, zij het de fabrikant of een wederverkoper, om het proces van gescheiden inzameling en verwerking in gang te zetten, na de van toepassing zijnde termen en voorwaarden van het verkoopcontract te hebben gecontroleerd.

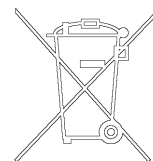

**GEVAAR!**

Alvorens werkzaamheden aan de controller uit te voeren, de voedingskabel afkoppelen.

Mocht de controller gesloopt worden, ga dan overeenkomstig de specifieke nationale wetgeving te werk.

**FOUTMELDINGEN**

In geval van storingen wekt het zelfdiagnose-circuit van de controller enkele foutmeldingen op die in de volgende tabel zijn omschreven.

<b>BOODSCHAP</b>	<b>OMSCHRIJVING</b>	<b>REMEDIE</b>
<b>CHECK CONNECTION TO PUMP</b>	Foutieve verbinding tussen pomp en controller. Of De pomp heeft een lagere temperatuur dan 0 °C.	Controleren of de verbindingskabel tussen pomp en controller aan beide uiteinden goed bevestigd is en geen onderbrekingen vertoond. Bedien twee maal de START-knop om de pomp weer op te starten.
<b>WAITING INTERLOCK</b>	Het interlock-sigitaal op connector P1 is actief wegens onderbreking van de kortsluiting tussen pin 3 en pin 8 van connector J1 of wegens het openen van het externe interlock-sigitaal.	Herstel de kortsluiting tussen pin 3 en pin 8 van connector J1 of sluit het externe interlock-sigitaal.
<b>PUMP OVERTEMP.</b>	De temperatuur van het bovenste pomplager bedraagt meer dan 60 °C.	Wacht tot de temperatuur weer onder de drempelwaarde is gezakt. Bedien twee maal de START-knop om de pomp weer op te starten.
<b>CONTROLLER OVERTEMP.</b>	De temperatuur van de controller bedraagt meer dan 70 °C. Of De temperatuur van de radiator van de controller bedraagt meer dan 60 °C.	Wacht tot de temperatuur weer onder de drempelwaarde is gezakt. Bedien twee maal de START-knop om de pomp weer op te starten.
<b>TOO HIGH LOAD</b>	De stroomopname van de pomp is groter dan de geprogrammeerde waarde.	Controleer of de pomprotor vrij kan draaien. Bedien twee maal de START-knop om de pomp weer op te starten.
<b>SHORT CIRCUIT</b>	Tijdens normale werking (na startfase) is de uitgangsverbinding in kortsluiting.	Controleer de verbindingen tussen pomp en controller. Bedien twee maal de START-knop om de pomp weer op te starten.
<b>SYSTEM OVERRIDE</b>	De pomp is stilgelegd door een noodsignaal afkomstig van een afstandscontact.	Koppel de voedingskabel van de controller af en elimineer de oorzaak van de noodstop. Sluit de voedingskabel weer aan en bedien twee maal de START-knop om de pomp weer op te starten.
<b>OVERVOLTAGE</b>	Er is een storing opgetreden in de voedingssectie van de controller of de controller heeft een stoorsigitaal ontvangen.	Bedien twee maal de START-knop om de pomp weer op te starten. Als de melding weer verschijnt zich voor onderhoud tot Varian wenden.
<b>POWER FAIL</b>	Defect in het voedingsgedeelte van de pomp, van de controller.	Neem contact op met Varian voor onderhoud.

## GENEREL INFORMATION

Dette materiel er beregnet til professionel anvendelse. Brugeren bør læse denne brugsanvisning og anden yderligere information fra Varian, før udstyret anvendes. Varian tager ikke ansvar for skader helt eller delvis som følge af tilsidesættelse af disse instruktioner, fejlagtig brug af personer uden tilstrækkelig kendskab, ukorrekt anvendelse af udstyret eller håndtering, der strider imod gældende lokale regler. Styreenhederne i Turbo-V 301 Rack serien er mikroprocessorstyrede frekvens-omformere, der består af komponenter med fast tilstand.

Styreenhed specifikationer:

- Frontal /fjern- /seriel styring
- 24 Vdc styring af pumpens blæser
- Vent valve styring
- Aflæsning af pumpens hastighed som følge af tryk på stop (aflæsning af stophastighed)
- Aflæsning af tryk
- Profibus brugerflade (ekstra)
- Automatisk indstilling af indgangsspændingen.

De følgende afsnit indeholder al information der behøves, for at garantere operatørens sikkerhed under anvendelsen. Detaljeret information findes i bilaget "Technical Information".

**I brugsanvisningen anvendes følgende standard-rubrikker:**



### **ADVARSEL !**

Advarselsmeddelelserne informerer operatøren om, at en speciel procedure eller en vis type arbejde skal udføres præcist efter anvisningerne. I modsat fald er der risiko for svære personskader.



### **VIGTIGT !**

Denne advarselsmeddelelse vises før procedurer, der skal følges nøje for ikke at risikere maskinskader.

### **BEMÆRK**

*Dette gør opmærksom på vigtig information i teksten.*

## OPBEVARING

Følgende krav til omgivelsesforholdene gælder ved transport og opbevaring af styreenheden:

- temperatur: fra -20 °C til +70 °C
- relativ luftfugtighed: 0 - 95%  
(ikke kondenserende)

## FORBEREDELSE FØR INSTALLATION

Styreenheden leveres i en speciel beskyttende emballage. Kontakt den lokale forhandler, hvis emballagen viser tegn på skader, der kan være opstået under transporten. Sørg for at styreenheden ikke tabes eller udsættes for stød ved udpakningen. Smid ikke emballagen ud. Materialet kan genbruges 100% og opfylder EU-direktiv 85/399 om miljøbeskyttelse.

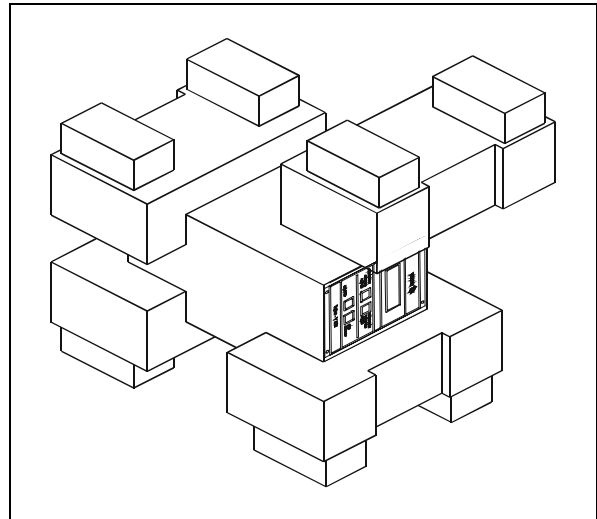

*Styreenhedens emballage*

## INSTALLATION

**ADVARSEL!**

For at sikre brugersikkerhed skal styreenheden tilkøbes et strømkabel med tre ledere (se reservedelslisten) og godkendt stik efter internationale standarder. Anvend udelukkende det medleverede strømkabel. I henhold til EU reglerne må stikket kun tilsluttes et vægudtag med fungerende jordtilslutning, for at undgå elektriske stød.

Spænding frembragt i styreenheden kan nå høje værdier og forårsage stor skade og dødsfald. Frakobel altid strømkablet, inden der udføres installations- eller vedligeholdelsesarbejde på styreenheden.

**BEMÆRK**

Styreenheden kan installeres på et bord eller et velegnet stativ. I begge tilfælde skal der være plads nok til, at luft kan cirkulere frit omkring apparatet. Installér og anvend ikke styreenheden i miljøer, der udsættes for påvirkninger fra atmosfæren (regn, sne, is), damp, aggressive gasser, og ligeledes ikke i eksplosivt eller brandfarligt miljø.

Følgende krav til omgivelserforholdene gælder ved drift:

- temperatur: fra 5 °C til +45 °C
- relativ luftfugtighed: 0 - 95% (ikke kondenserende)

For øvrige tilslutninger og installation af tilbehør henvises til afsnittet "Technical Information".

## ANVENDELSE

Dette afsnit beskriver de vigtigste driftsprocedurer. For en detaljeret beskrivelse samt procedurer, der involverer tilslutninger eller tilbehør, henvises til afsnittet "Use" i bilag "Technical Information".

Inden styreenheden anvendes, bør samtlige elektriske og pneumatiske tilslutninger udføres. Læs brugsanvisningen før pumpen tilsluttes.

**ADVARSEL!**

Sørg for, at pumpen står fast, hvis den er installeret på et bord. Dette er for at forebygge skader på apparatet og personer. Start aldrig pumpen, hvis pumpetilløbet ikke er tilsluttet systemet eller er blokeret.

**BEMÆRK**

Afbryderkontakten J1 skal forblive tilsluttet med aktuel bro, når der ikke udføres eksterne tilslutninger. Før-vakuumpumpen og Turbo-V-pumpen skal fungere samtidigt.

**Indikatorer og kontakter på styreenheden**

Nedenfor vises styreenhedens front- og bagpanel. For yderligere information henvises til bilag "Technical Information".

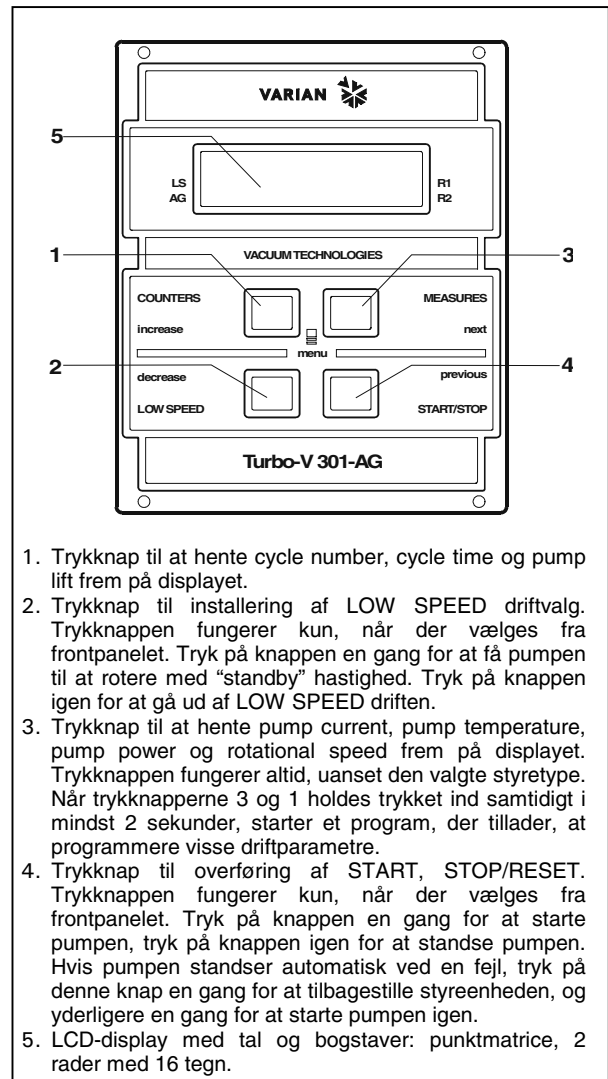
**Beskrivelse af frontpanel**

1. Trykknop til at hente cycle number, cycle time og pump lift frem på displayet.
2. Trykknop til installering af LOW SPEED driftvalg. Trykknappen fungerer kun, når der vælges fra frontpanelet. Tryk på knappen en gang for at få pumpen til at rotere med "standby" hastighed. Tryk på knappen igen for at gå ud af LOW SPEED driften.
3. Trykknop til at hente pump current, pump temperature, pump power og rotational speed frem på displayet. Trykknappen fungerer altid, uanset den valgte styretype. Når trykknapperne 3 og 1 holdes trykket ind samtidigt i mindst 2 sekunder, starter et program, der tillader, at programmere visse driftparametre.
4. Trykknop til overføring af START, STOP/RESET. Trykknappen fungerer kun, når der vælges fra frontpanelet. Tryk på knappen en gang for at starte pumpen, tryk på knappen igen for at standse pumpen. Hvis pumpen standser automatisk ved en fejl, tryk på denne knap en gang for at tilbagesætte styreenheden, og yderligere en gang for at starte pumpen igen.
5. LCD-display med tal og bogstaver: punktmatrix, 2 rader med 16 tegn.

Frontpanelet på Styreenheden Turbo-V 301-AG



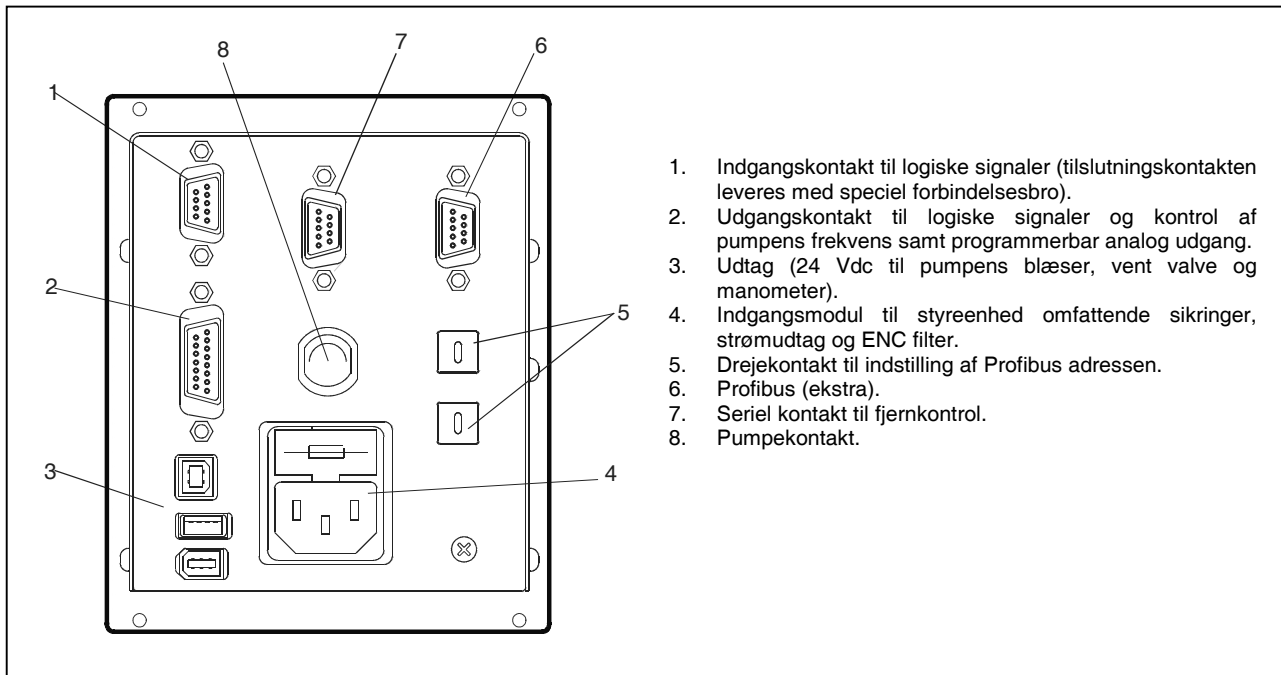

Bagpanelet på Styreenheden Turbo-V 301-AG

## INSTRUKTION

### Start af styreenheden

Styreenheden startes ved at sætte strømkablet i vægudtaget.

### Start af pumpen

Pumpen startes ved at aktivere interlock indgangen og trykke på START-knappen på frontpanelet.

### Stop af pumpen

Pumpen stopper ved at trykke på STOP-trykknappen på frontpanelet.

## VEDLIGEHOLDELSE

Styreenhederne i Turbo-V 301 Rack serien behøver ikke nogen vedligeholdelse. Ethvert indgreb på pumpen skal foretages af autoriseret personale.

Hvis styreenheden går i stykker, kan man benytte sig af Varians reparations-service eller Varian udvekslingsservice, hvor man kan få en repareret pumpe i bytte for den, der er gået i stykker.



### ADVARSEL!

Inden der foretages noget som helst indgreb på styreenheden, skal strømmen først afbrydes.

Skrotning af styreenheden skal foregå i overensstemmelse med det pågældende lands særlige love.

## BORTSKAFFELSE

**Betydningen af "WEEE" logoet på mærkaterne.** Nedenstående symbol anvendes i overensstemmelse med det såkaldte EU-direktiv "WEEE". Symbolet (**kun gældende for EU-landene**) viser, at produktet, som det sidder på IKKE må bortskaffes sammen med affald fra private husholdninger eller industriel affald men skal indleveres på en godkendt affaldsstation. Vi opfordrer derfor slutbrugeren til at kontakte leverandøren af anordningen, enten fabrikken eller en forhandler, for igangsættelse af afhentnings- og bortskaffelsesprocessen efter nøje at have kontrolleret betingelserne i salgskontrakten.

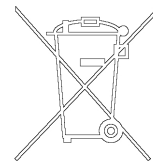

## FEJLMEDDELELSER

Når visse fejl opstår, viser styreenheden ved selvdiagnose aktuelle fejl på displayet. De mulige meddelelser listes i følgende tabel.

MEDDELELSE	BESKRIVELSE	KONTROL
<b>CHECK CONNECTION TO PUMP</b>	Tilslutning mellem pumpe og styreenhed er defekt. eller Temperaturen på pumpen ligger under 0 °C.	Kontrollér at tilslutningskabel mellem pumpe og styreenhed er korrekt monteret samt at ingen afbrydninger forekommer. Tryk to gange på START for at starte pumpen igen.
<b>WAITING INTERLOCK</b>	Interlocksignalet findes på kontakt P1 p.g.a. kortslutning mellem stift 3 og stift 8 i kontakten J1 eller p.g.a. at det eksterne interlocksignal er åbent.	Tilbagestil kortslutningen mellem stift 3 og stift 8 på kontakt J1 eller sluk for det eksterne interlocksignal.
<b>PUMP OVERTEMP.</b>	Temperaturen på det øverste leje eller pumpen overskrider 60 °C.	Vent på at temperaturen falder til under tærskelværdi. Tryk to gange på START for at starte pumpen igen.
<b>CONTROLLER OVERTEMP.</b>	Temperaturen på styreenhedens overskrider 70 °C. eller Temperaturen på styreenhedens køler overskrider 60 °C.	Vent på at temperaturen falder til under tærskelværdi. Tryk to gange på START for at starte pumpen igen.
<b>TOO HIGH LOAD</b>	Under normal drift (efter startfasen) forbruger pumpen en større effekt end den programmerede værdi.	Kontrollér om pumpens rotor kan rotere frit. Tryk to gange på START for at starte pumpen igen.
<b>SHORT CIRCUIT</b>	Under normal drift (efter startfasen) er udgangseffekten kortsluttet. Strømmen, som optages af pumpen overskrider den programmerede værdi.	Kontrollér forbindelserne mellem pumpe og styreenhed. Tryk to gange på START for at starte pumpen igen.
<b>SYSTEM OVERRIDE</b>	Pumpen er blevet standset af et nødstopsignal fra en fjernkontakt.	Frakobl styreenhedens strømkabel og kontrollér årsagen til nødstoppet. Sæt derefter strømkablet i. Tryk to gange på START, for at starte pumpen igen.
<b>OVERVOLTAGE</b>	Der er opstået fejl i styreenhedens fødespænding eller styreenheden har fået et falsk signal.	Tryk to gange på START-knappen for at starte pumpen igen. Hvis meddelelsen kommer igen tag kontakt med Varian for nødvendig vedligeholdelse.
<b>POWER FAIL</b>	Der er opstået fejl i sektionen for strømtilførsel til pumpen, styreenheden.	Tag kontakt med Varian for Vedligeholdelse.

## ALLMÄN INFORMATION

Utrustningen är avsedd för yrkesmässig användning. Användaren bör läsa denna bruksanvisning, samt övrig dokumentation från Varian före användning av utrustningen. Varian tar inget ansvar för skador som helt eller delvis orsakats av åsidosättande av instruktionerna, olämplig användning av person utan tillräcklig kunskap, obehörigt bruk av utrustningen eller hantering som strider mot gällande lokala föreskrifter. Styrenheterna i Turbo-V 301 Rack serien är mikroprocessor-styrda frekvensomvandlare som består av komponenter med fast tillstånd. Styrenheterna är försedda med självdiagnos- och självskyddsfunktion.

Styrenhetens egenskaper:

- Front- / fjärr- /seriell styrning
- 24 Vdc styrning av pumpens kylfläkt
- Vent valve styrning
- Avläsning av pumphastighet efter kommando för stopp (avläsning av stopphastighet)
- Avläsning av tryck
- Profibus gränssnitt (option)
- Automatisk inställning av inspänning.

De följande avsnitten innehåller all information som behövs för att garantera operatörens säkerhet under driften. Detaljerade uppgifter finns i bilagan "Technical information".

**I bruksanvisningen används följande standard-rubriker:**



### **VARNING!**

Varningsmeddelandena informerar operatören om att en speciell procedur eller en viss typ av arbete måste utföras exakt enligt anvisningarna. I annat fall finns risk för svåra personskador.



### **VIKTIGT!**

Detta varningsmeddelande visas framför procedurer som måste följas exakt för att undvika skador på maskinen.

### **OBSERVERA**

*Detta visar på viktig information i texten.*

## FÖRVARING

Följande krav på omgivningsförhållanden gäller vid transport och förvaring av styrenheten:

- temperatur: från -20 °C till +70 °C
- relativ luftfuktighet: 0 - 95% (utan kondens)

## FÖRBEREDELSE FÖR INSTALLATION

Styrenheten levereras i ett särskilt skyddande emballage. Kontakta det lokala försäljningskontoret om emballaget visar tecken på skador som kan ha uppstått under transporten.

Se till att styrenheten inte tappas eller utsätts för stötar vid upppackningen.

Kasta inte packmaterialet i soporna. Materialet är återvinningsbart till 100% och uppfyller EU-direktiv 85/399 om miljöskydd.

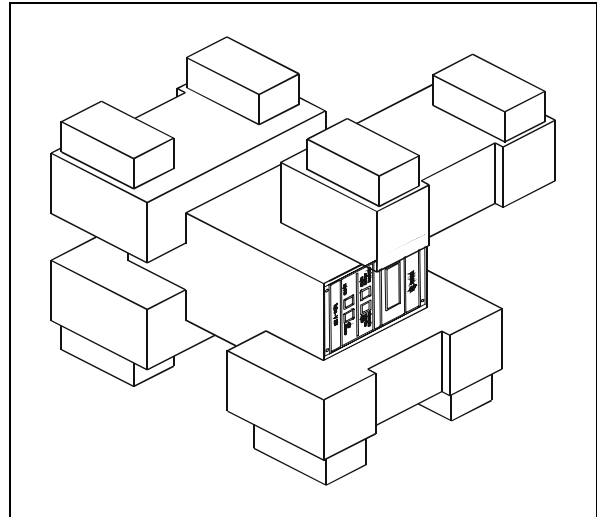

*Styrenhetens förpackning*

## INSTALLATION

**WARNING!**

Styrenheten fungerar med en strömkabel som har tre ledare (se tabellen som visar de delar som kan beställas) och för användarens säkerhet ska den ha godkänd stickpropp enligt internationella standarder. Använd alltid denna strömkabel och anslut stickproppen till ett vägguttag med fungerande jordanslutning för att undvika elstötar och för iakttagelse av CE specifikationer.

Spänningen inuti styrenheten kan nå höga värden och förorsaka allvarliga skador och dödsfall. Dra alltid ur strömkabeln från vägguttaget innan något installations- eller underhållsmoment utförs på styrenheten.

**OBSERVERA**

Styrenheten kan installeras på ett bord eller inuti ett därtill avsett rack. I samtliga fall måste dock kyl Luft kunna cirkulera fritt kring apparaten. Installera och använd inte styrenheten i miljöer som utsätts för påverkan från atmosfären (regn, snö, is), damm, aggressiva gaser, och inte heller i explosiv eller brandfarlig miljö.

Följande krav på omgivningsförhållanden gäller vid drift:

- temperatur: från 5 °C till +45 °C
- relativ luftfuktighet: 0 - 95% (utan kondens).

Beträffande övriga anslutningar och installation av tillbehör hänvisas till avsnittet "Technical Information".

## ANVÄNDNING

Detta avsnitt beskriver de viktigaste driftmomenten. För en detaljerad beskrivning samt beträffande moment som involverar anslutningar eller tillbehör hänvisas till avsnittet "Use" i bilaga "Technical Information".

Innan styrenheten används bör samtliga elektriska och pneumatiska anslutningar utföras.

Läs bruksanvisningen för den anslutna pumpen.

**WARNING!**

Försäkra dig att pumpen står stadigt, om den är installerad på ett bord, detta för att förebygga skador på apparaten och personer. Sätt aldrig igång pumpen, om intagsflänsen varken är kopplad till systemet eller är blockerad på plats med låsflänsen.

**OBSERVERA**

Stängningskontakten J1 måste lämnas ansluten med aktuell brygga om ingen extern anslutning utförs. Förvakuum-pumpen och Turbo-V-pumpen kan fungera samtidigt.

**Indikatorer och kontakter på Styrenheten**

Nedan visas styrenhetens front- och bakpanel. För ytterligare information hänvisas till bilaga "Technical Information".

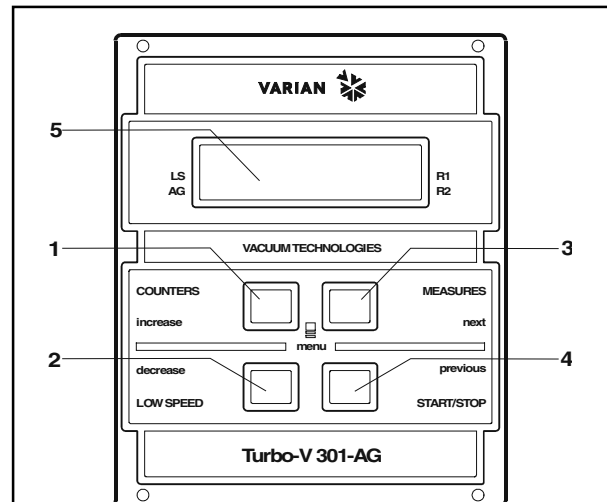
**Beskrivning av frontpanel**

1. Tryckknapp för att hämta parametrarna cycle number, cycle time och pump life på displayen.
2. Tryckknapp för inställning av LOW SPEED driftsätt. Tryckknappen fungerar endast när styrsätt från frontpanelen har valts. Genom att trycka på knappen en gång kommer pumpen att rotera vid "standby" hastighet. Tryck på knappen igen för att gå ur LOW SPEED driftsättet.
3. Tryckknapp för att hämta parametrarna pump current, pump temperature, pump power och rotational speed på displayen. Tryckknappen fungerar alltid, oavsett det valda styrsättet. När tryckknapparna 3 och 1 hålls samtidigt intryckta i minst 2 sekunder, startas ett program som tillåter att programmera vissa driftparametrar.
4. Tryckknapp för överföring av START, STOP/RESET. Tryckknappen fungerar endast när styrsätt från frontpanelen har valts. Tryck på knappen en gång för att starta pumpen, tryck på knappen igen för att stanna pumpen. Om pumpen stannat automatiskt i samband med ett fel, tryck på denna knapp en gång för att återställa styrenheten, och ytterligare en gång för att starta om pumpen.
5. LCD-display med siffror och bokstäver: punktmatrix, 2 rader med 16 tecken.

Frontpanelen på Styrenheten Turbo-V 301-AG

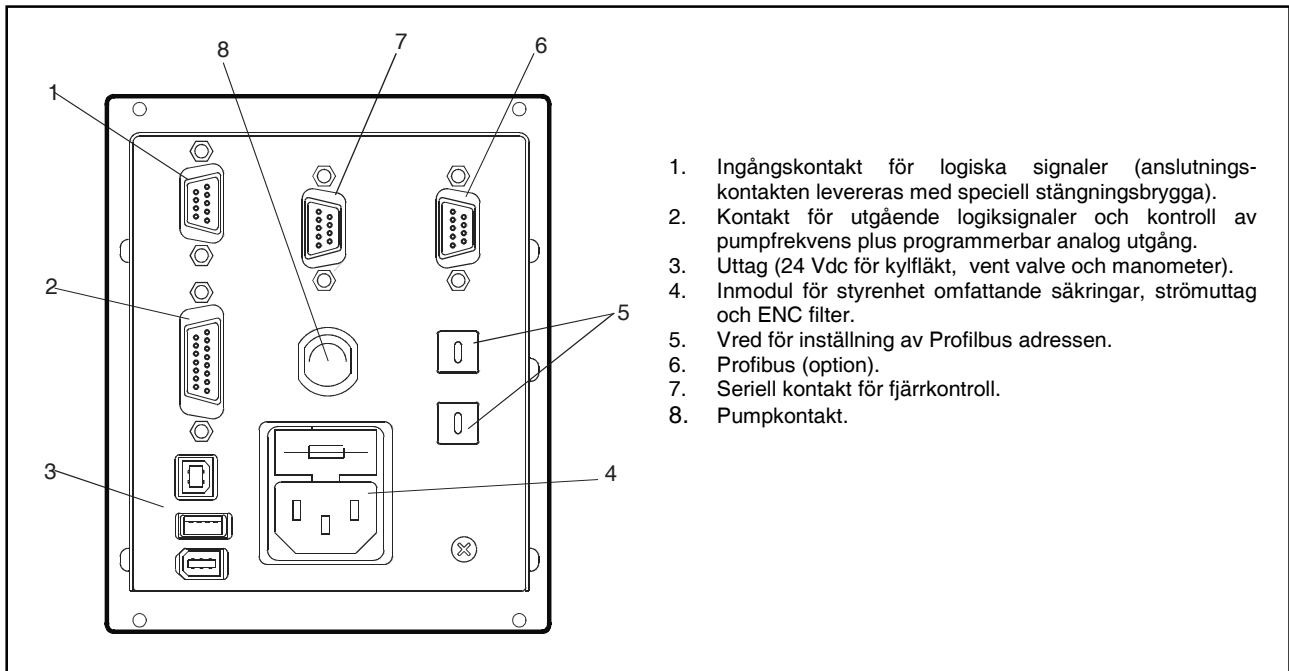

1. Ingångskontakt för logiska signaler (anslutningskontakten levereras med speciell stängningsbrygga).
2. Kontakt för utgående logiksignaler och kontroll av pumpfrekvens plus programmerbar analog utgång.
3. Uttag (24 Vdc för kylfläkt, vent valve och manometer).
4. Inmodul för styrenhet omfattande säkringar, strömuttag och ENC filter.
5. Vred för inställning av Profibus adressen.
6. Profibus (option).
7. Seriell kontakt för fjärrkontroll.
8. Pumpkontakt.

Bakre panel på Styrenheten Turbo-V 301-AG

## INSTRUKTIONER FÖR BRUK

### Start av styrenheten

Styrenheten startas enkelt genom att sätta strömkabeln i vägguttaget.

### Start av pumpen

Vid start av pumpen måste ingången till interlock aktiveras och START-knappen tryckas in på frontpanelen.

### Stopp av pumpen

Pumpen stoppas genom att trycka på tryckknappen STOPP på frontpanelen.

## UNDERHÅLL

Styrenheterna i Turbo-V 301 Rack serien är underhållsfria. Allt servicearbete måste utföras av auktoriserad personal.

Om styrenheten havererar, kontakta Varian reparationsverkstad eller Varian utbytesservice, som kan ersätta styrenheten med en renoverad styrenhet.



**VARNING!**

Innan något arbete utförs på styrenheten måste dess strömförsörjning brytas.

Skrotning av styrenheten skall ske enligt gällande lagstiftning.

## BORTSKAFFNING

**Betydelse av logotypen "WEEE" på etiketterna.** Symbolen som visas nedan har tillämpats i enlighet med CD-direktivet som har betecknats som "WEEE". Den här symbolen (**gäller endast i de länder som tillhör den Europeiska Unionen**) indikerar att produkten på vilken symbolen har applicerats INTE får skaffas bort tillsammans med vanliga hushålls- eller industriavfall, men att däremot ett differentierat uppsamlingsystem måste upprättas. Vi rekommenderar därför att slutanvändaren tar kontakt med leverantören av anordningen, oberoende om det handlar om moderföretaget eller återförsäljaren, för att kunna starta uppsamlings- och bortskaffningsprocessen, detta efter lämplig kontroll av kontraktsevenliga tidsgränser och försäljningsvillkor.

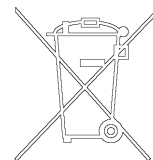

## FELMEDDELANDEN

När vissa fel uppstår visar styrenhetens självdiagnoskrets aktuellt felmeddelande på displayen. De möjliga meddelandena listas i följande tabell.

MEDDELANDE	BESKRIVNING	ÅTGÄRD
<b>CHECK CONNECTION TO PUMP</b>	Anslutningen mellan pump och styrenhet är defekt. eller också Pumpens temperatur ligger under 0 °C.	Kontrollera att anslutningskabeln mellan pump och styrenhet är ordentligt monterad samt att inget avbrott förekommer. Tryck två gånger på knappen START för att starta om pumpen.
<b>WAITING INTERLOCK</b>	Interlock-signalen finns på kontakt P1 på grund av kortslutning mellan stift 3 och stift 8 i kontakten J1, eller på grund av att den externa interlock-signalen är öppen.	Åtgärda kortslutningen mellan stift 3 och stift 8 på kontakt J1 eller stäng den externa interlock-signalen.
<b>PUMP OVERTEMP.</b>	Temperaturen på det övre lagret eller pumpen överskrider 60 °C.	Vänta tills temperaturen sjunker under tröskelvärdet. Tryck två gånger på knappen START för att starta om pumpen.
<b>CONTROLLER OVERTEMP.</b>	Temperaturen på styrenhetens överskrider 70 °C. eller också Temperaturen på styrenhetens kylare överskrider 60 °C.	Vänta tills temperaturen sjunker under tröskelvärdet. Tryck två gånger på knappen START för att starta om pumpen.
<b>TOO HIGH LOAD</b>	Strömmen som absorberas av pumpen överstiger det värde som programmerats.	Kontrollera att pumpens rotor kan rotera fritt. Tryck två gånger på knappen START för att starta om pumpen.
<b>SHORT CIRCUIT</b>	Under normal drift (efter startmomentet) har utgången kortslutits.	Kontrollera anslutningarna mellan pump och styrenhet. Tryck två gånger på knappen START för att starta om pumpen.
<b>SYSTEM OVERRIDE</b>	Pumpen har stannats av en nödstoppsignal från en fjärrkontakt.	Frånkoppla styrenhetens strömkabel och kontrollera nödstoppets orsak. Sätt därefter i strömkabeln. Tryck två gånger på knappen START för att starta om pumpen.
<b>OVERVOLTAGE</b>	Ett fel i styrenhetens matningsdel har uppstått eller styrenheten har fått en falsk signal.	Tryck två gånger på knappen START för att starta om pumpen. Om meddelandet visas igen, ta kontakt med Varian för nödvändigt underhåll.
<b>POWER FAIL</b>	Fel i sektionen för strömtillförsel till pumpen, styrenheten.	Ta kontakt med Varian för Underhåll.

## GENERELL INFORMASJON

Dette utstyret er beregnet til bruk av profesjonelle brukere. Brukeren bør lese denne brukerveiledningen og all annen informasjon fra Varian før utstyret tas i bruk. Varian kan ikke holdes ansvarlig for hendelser som skjer på grunn av manglende oppfølging, selv delvis, av disse instruksjonene, feilaktig bruk av utrenet personell, ikke godkjente endringer av utstyret eller handlinger som på noen måte er i strid med nasjonale bestemmelser. Styreenhetene i Turbo-V 301 Rack serien er mikroprosessor-styrte frekvensomvendere, som består av komponenter med fast tilstand. Styreenhetene har funksjoner for selvdiagnose og selvbeskyttelse.

Styreenhetens karakteristikk:

- Frontal virksomhet / fjern / seriell
- Igangsetting av kjøleviften på 24 Vdc på pumpen
- Igangsetting av vent valve
- Avlesing av pumpehastighet etter stoppekommando (avlesing av stoppehastighet)
- Avlesing av trykk
- Grensesnitt Profibus (valgfritt)
- Automatisk innstilling av inngangsspenning

De følgende avsnittene inneholder all informasjon som er nødvendig for å sikre brukeren når utstyret er i bruk. For mer detaljert bruk vises det til tillegget "Technical Information".

**Denne veiledningen bruker følgende standard-protokoll:**



### ADVARSEL!

Disse meldingene skal tiltrekke seg brukerens oppmerksomhet til en spesiell fremgangsmåte eller praksis som, hvis den ikke følges, kan medføre alvorlige skader.



### FORSIKTIG!

Denne advarselen vises foran fremgangsmåter som, dersom de ikke følges, kan føre til at utstyret skades.

### MERK

*Merknadene inneholder viktig informasjon som er hentet fra teksten.*

## LAGRING

Når styreenhetene transporteres eller lagres, må følgende forhold være oppfylt:

- temperatur: fra 20 °C til +70 °C
- relativ fuktighet: 0 - 95% (uten kondens)

## FORBEREDE INSTALLASJONEN

Styreenheten leveres i en spesiell beskyttelsesemballasje. Viser denne tegn på skader som kan ha oppstått under transporten, må du ta kontakt med det lokale salgskontoret.

Når styreenheten pakkes ut, må du passe på at den ikke slippes ned eller utsettes for noen form for støt. Emballasjen må ikke kastes på en ulovlig måte. Alle materialer er 100% resirkulerbare og er i samsvar med EU-direktiv 85/399 om miljøbeskyttelse.

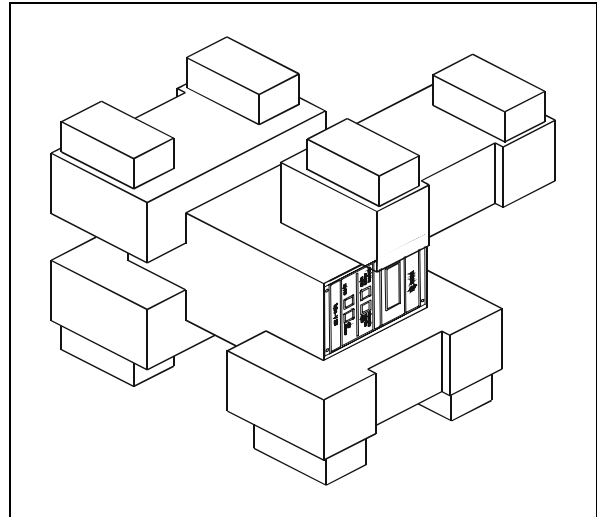

*Styreenhetens emballasje*

## INSTALLASJON

**ADVARSEL!**

Styreenheten må koples til en strømkabel med tre ledere (se tabellen over deler som kan bestilles) med et støpsel godkjent i henhold til internasjonale standarder til sikkerhet for brukeren. Bruk alltid denne strømkabelen og sett støpselet i en kontakt med passende jordledning, for å unngå elektriske støter og for å holde seg til CE-normene.

Inne i styreenheten utvikles høye spenninger som kan føre til alvorlige skader eller dødsfall. Kople alltid strømkabelen fra strømmettet før enhver installering eller vedlikehold av styreenheten utføres.

**MERK**

Styreenheten kan installeres på et bord eller inne i et passende stativ. Uansett så må kjøleluften kunne sirkulere fritt rundt apparatet. Ikke installer eller bruk styreenheten i miljøer som utsettes for regn, snø eller is, støv, aggressive gasser, eksplosjonsfarlige miljøer eller i miljøer med stor brannfare.

Under bruk må følgende forhold respekteres:

- temperatur: fra 5 °C til +45 °C
- relativ fuktighet: 0 - 95% (uten kondens)

Når det gjelder andre tilkoblinger og installasjon av ekstrautstyr vises det til avsnittet "Technical Information".

## BRUK

Dette avsnittet beskriver de viktigste driftsmomentene. For en detaljert beskrivelse samt moment som omfatter tilkoblinger eller ekstrautstyr vises det til avsnittet "Use" i vedlegget "Technical Information".

Før styreenheten tas i bruk bør samtlige elektriske og pneumatiske tilkoblinger gjøres. Les bruker-veiledningen for pumpen som er tilkopleet.

**ADVARSEL!**

Dersom pumpen er installert på et bord må du kontrollere at pumpen står støtt. Dette er viktig for å forhindre skader på apparatet og på personer. Dersom inngangsflynsen hverken er tilkopleet systemet eller dersom den er blokkert av låseflynsen må pumpen aldri startes opp.

**MERK**

Lukkekontakten J1 må være tilkopleet aktuell brygge dersom det ikke skjer en annen ekstern tilkopleing. Forvakuumpumpen og Turbo-V-pumpen må fungere sammen.

**Indikatorer og kontakter på styreenheten**

Nedenunder er frontpanelet og bakpanelet på styreenheten illustrert. For ytterligere informasjon vises det til avsnittet "Accessories and Spare Parts" i vedlegget "Technical Information".

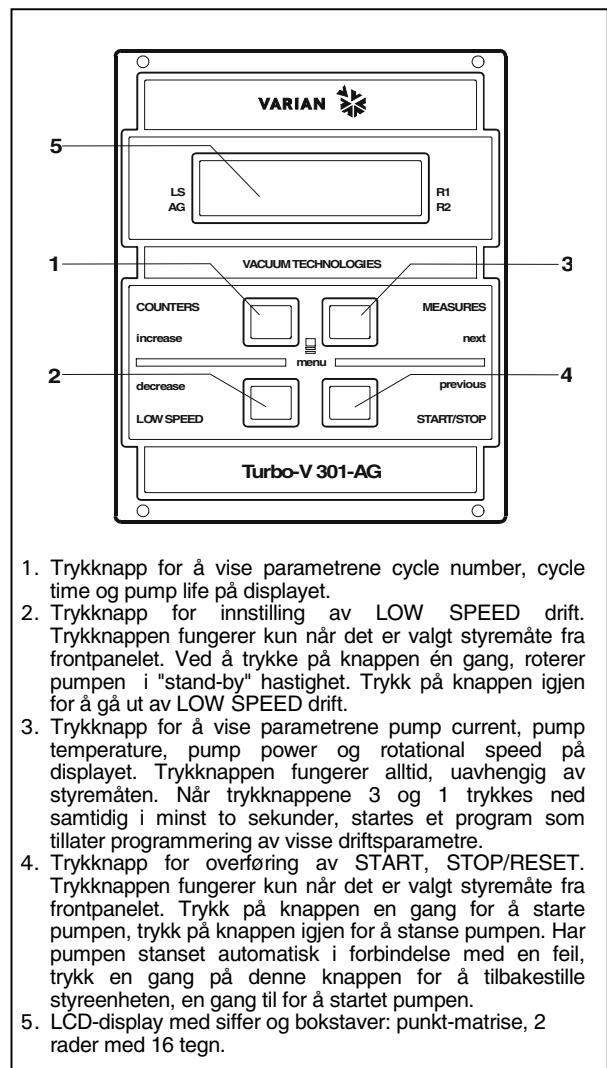
**Beskrivelse av frontpanelet**

1. Trykknapp for å vise parametrene cycle number, cycle time og pump life på displayet.
2. Trykknapp for innstilling av LOW SPEED drift. Trykknappen fungerer kun når det er valgt styremåte fra frontpanelet. Ved å trykke på knappen én gang, roterer pumpen i "stand-by" hastighet. Trykk på knappen igjen for å gå ut av LOW SPEED drift.
3. Trykknapp for å vise parametrene pump current, pump temperature, pump power og rotational speed på displayet. Trykknappen fungerer alltid, uavhengig av styremåten. Når trykknappene 3 og 1 trykkes ned samtidig i minst to sekunder, startes et program som tillater programmering av visse driftsparametre.
4. Trykknapp for overføring av START, STOP/RESET. Trykknappen fungerer kun når det er valgt styremåte fra frontpanelet. Trykk på knappen en gang for å starte pumpen, trykk på knappen igjen for å stanse pumpen. Har pumpen stanset automatisk i forbindelse med en feil, trykk en gang på denne knappen for å tilbakestille styreenheten, en gang til for å startet pumpen.
5. LCD-display med siffer og bokstaver: punkt-matrise, 2 rader med 16 tegn.

Frontpanelet på styreenheten Turbo-V 301-AG



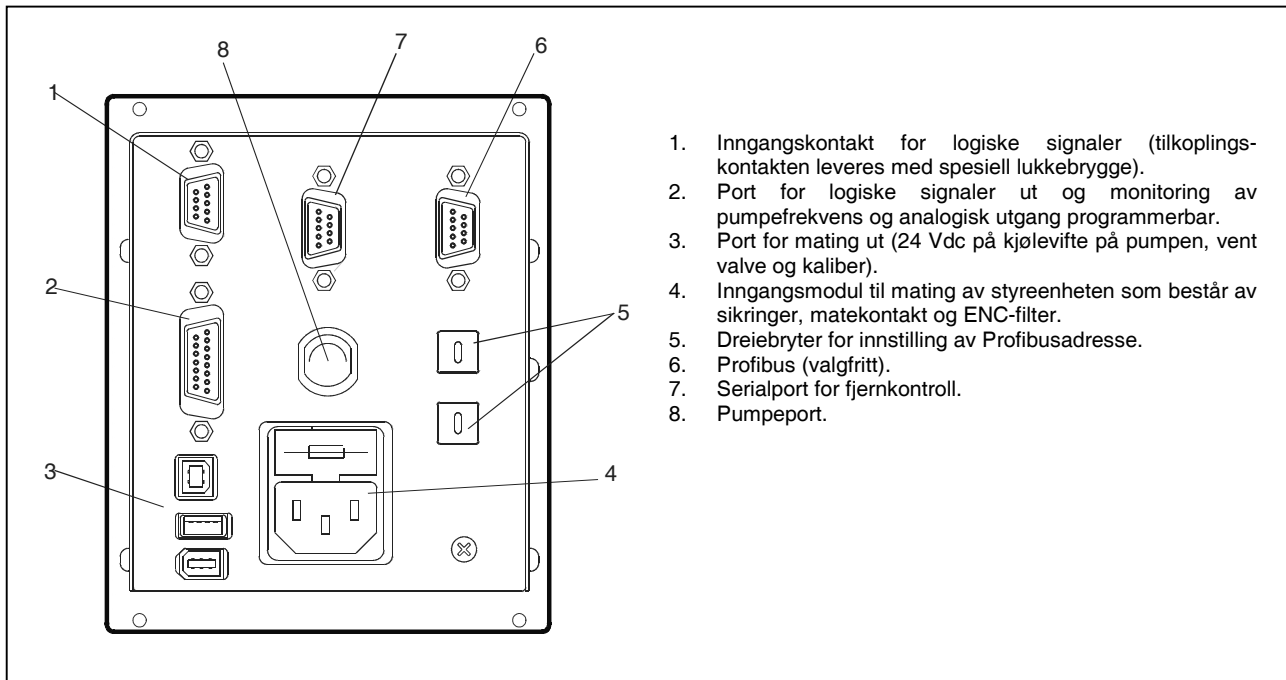

Bakpanelet på styreenheten Turbo-V 301-AG

## INSTRUKSJONER FOR BRUK

### Starte styreenheten

Styreenheten startes ved å sette strømkabelen i veggkontakten.

### Starte pumpen

For å starte pumpen må man preparere interlockinngangen og trykke på knappen START på frontpanelet.

### Stoppe pumpen

Pumpen stoppes ved å trykke på knappen STOPP på frontpanelet.

## VEDLIKEHOLD

Turbo-V 301 Rack seriens styreenheter er vedlikeholdsfrie. Alt arbeid på styreenheten må kun utføres av autorisert personell.

Dersom styreenheten stanser, må du ta kontakt med Varians reparasjonsservice eller med Varians avanserte bytteservice, som kan tilby overhalte styreenheter til erstatning for den ødelagte styreenheten.



### ADVARSEL!

Før noe arbeid utføres på styreenheten, må den frakoples strømmettet.

Dersom en styreenhet skal kasseres, må dette skje i henhold til nasjonale bestemmelser.

## ELIMINERING

**Betydelsen av symbolet på logo "WEEE" på etikettene.**

Symbolet nedenunder som finnes, er anvendt i henhold til EC-direktiv kalt "WEEE".

Dette symbolet (**som bare gjelder for land i Det europeiske fællesskap**), viser at produktet som det sitter på, IKKE må behandles som vanlig husindustriavfall, men må legges i kildesortering.

Derfor oppfordrer man den sluttelige brukeren av anordningen å henvende seg til leverandøren av anordningen, som kan være et firma eller en forhandler, som sørger for oppsamling og eliminering etter å ha kontrollert avtal og betingelser i kjøpekontrakten.

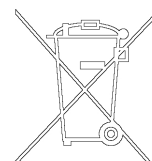

## FEILMELDINGER

Når det oppstår visse feil viser selvdiagnosekretsen i styreenheten den aktuelle feilmeldingen i displayet. De aktuelle feilmeldingen fremgår av tabellen nedenfor.

MELDING	BESKRIVELSE	FORHOLDSREGEL
<b>CHECK CONNECTION TO PUMP</b>	Defekt kabling mellom pumpe og styreenhet. Eller Pumpen har en temperatur under 0 °C.	Kontroller at tilkoplingskabelen mellom pumpe og styreenhet er skikkelig montert samt at kabelen ikke er skadet. Trykk to ganger på knappen START for å starte pumpen.
<b>WAITING INTERLOCK</b>	Låsesignalet for kontakt P1 skyldes en kortslutning mellom stift 3 og stift 8 i kontakten J1 eller fordi det eksterne låsesignalet er åpent.	Tilbakestill kortslutningen mellom stift 3 og stift 8 på kontakt J1 eller steng det eksterne låsesignalet.
<b>PUMP OVERTEMP.</b>	Temperaturen på det øvre lageret eller pumpen er over 60 °C.	Vent til temperaturen synker under terskelverdien. Trykk to ganger på knappen START for å starte pumpen.
<b>CONTROLLER OVERTEMP.</b>	Temperaturen på styreenhetens er over 70 °C. Eller Temperaturen på radiatoren på styreenheten er over 60 °C.	Vent til temperaturen synker under terskelverdien. Trykk to ganger på knappen START for å starte pumpen.
<b>TOO HIGH LOAD</b>	Den absorberte strømmen av pumpen er større enn den som er programmert	Kontroller om pumpens rotor kan rotere fritt. Trykk to ganger på knappen START for å starte pumpen.
<b>SHORT CIRCUIT</b>	Ved normal drift (etter startmomentet) er utgangen kortsluttet.	Kontroller tilkoplingene mellom pumpe og styreenhet. Trykk to ganger på knappen START for å starte pumpen.
<b>SYSTEM OVERRIDE</b>	Pumpen har stanset av et nødstoppsignal en fra fjernkontakt.	Kople fra styreenhetens strømkabel og finn frem til årsaken til nødstoppen. Kople deretter maskinen til strømnettet igjen. Trykk to ganger på knappen START for å starte pumpen.
<b>OVERVOLTAGE</b>	Det har oppstått en feil i styreenhetens matedel, eller så har styreenheten fått et falskt signal.	Trykk to ganger på knappen START for å starte pumpen igjen. Viser feilmeldingen om igjen, må du ta kontakt med Varian for nødvendig vedlikehold.
<b>POWER FAIL</b>	Feil på matesektoren på pumpen, på styreenheten.	Henvend deg til Varian for vedlikehold.

## YLEISIÄ TIETOJA

Tämä laite on tarkoitettu ammattimaiseen käyttöön. Ennen laitteen käyttöönottoa käyttäjän tulee lukea huolellisesti mukana seuraava käyttöohje sekä kaikki muut Varianin toimittamat lisätiedot. Varian ei vastaa seurauksista, jotka johtuvat laitteen käyttöohjeiden täydellisestä tai osittaisesta laiminlyömisestä, ammattitaidottomien henkilöiden suorittamasta laitteen virheellisestä käytöstä, valtuuttamattomista toimenpiteistä tai maakohtaisten säädösten ja normien vastaisesta käytöstä.

Sarjan Turbo-V 301 Rack valvojat ovat mikroprosessorien valvomia kiinteistä materiaaleista tehtyjä taajuudenmuuntimia, jotka kykenevät itsemäärittelyyn ja itsesuojaukseen.

Valvojan ominaisuudet:

- Käytettävyys etupaneelista / etäkäyttö / sarjakäyttö
- Pumpun jäähdytyssiivikon 24V tasavirtaohjaus
- Vent valve ohjaus
- Pumpun nopeuden luku pysäytyskäskyn jälkeen (pysäytysnopeuden luku)
- Paineen luku
- Profibus-liitäntä (valinnainen)
- Automaattinen sisääntulon jännitteen asetus.

Seuraavilla sivuilla on luettavissa tarpeelliset tiedot laitteen käyttäjän turvallisuuden takaamiseksi laitteen käytön aikana. Yksityiskohtaiset tiedot löytyvät liitteestä "Technical Information".

**Tämä käsikirja käyttää seuraavia merkintöjä:**



**VAARA!**

Vaara-merkinnät saavat käyttäjän huomion kiinnittymään erityisiin toimintotapoihin, joiden seuraamatta jättäminen voi aiheuttaa vakavia henkilövaurioita.



**HUOMIO!**

Huomio-merkinnät varoittavat toiminnoista, joiden laiminlyönti voi johtaa laitteen vaurioitumiseen.

**HUOM**

*Huomiot sisältävät tärkeätä tekstistä otettua tietoa.*

## VARASTOINTI

Valvojan kuljetuksen ja varastoinnin aikana tulevat seuraavat ympäristövaatimukset olla täytettyinä:

- lämpötila: -20 °C ja +70 °C asteen välillä
- suhteellinen kosteus: 0 - 95% (ilman lauhdetta)

## VALMISTELUT ASENNUSTA VARTEN

Valvoja toimitetaan erityisessä suojaavassa pakkauksessa. Mikäli havaitsette mahdollisesti kuljetuksen aikana sattuneita vaurioita, ottakaa yhteys paikalliseen myyntitoimistoon.

Pakkauksen purkamisen yhteydessä huolehtikaa, että valvoja eipääse putoamaan ja välttää sen joutumista iskujen kohteeksi.

Älkää jättäkö pakkausta ympäristöön. Materiaali voidaan kokonaisuudessaan kierrättää ja se vastaa EY:n 85/399 direktiiviä ympäristön suojelusta.

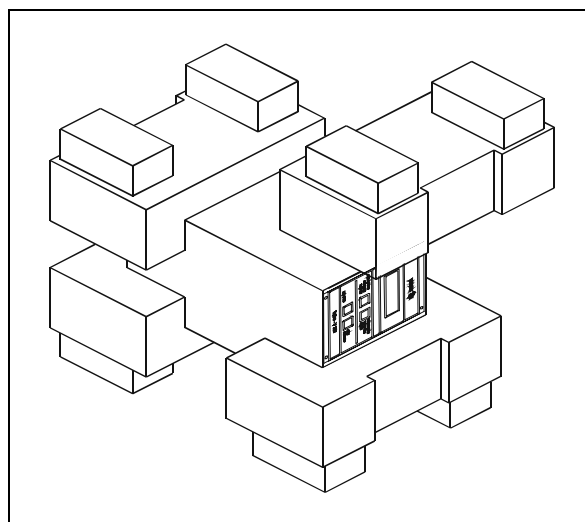

*Valvojan pakkaus*

## ASENNUS

**VAARA!**

Käyttäjän turvallisuuden vuoksi valvojan virranottoon on käytettävä kolmijohtimista sähkökaapelia (ks. tilattavien osien taulukko), jonka pistoke on kansainvälisesti hyväksyttyä tyyppiä. Käytä aina tätä kaapelia ja kiinnitä pistoke asianmukaisesti maadoitettuun pistorasiaan sähköiskujen välttämiseksi ja CE-vaatimusten noudattamiseksi.

Valvojan sisällä muodostuu korkeajännitettä, joka voi aiheuttaa vakavia vammoja tai jopa kuoleman. Ennen mihinkään asennus- tai huoltotoimenpiteisiin ryhtymistä valvojan pistoke on irrotettava pistorasiasta.

**HUOM**

Valvoja voidaan asentaa pöydän päälle tai siihen tarkoitukseen sopivan hyllyn sisään. Joka tapauksessa huolehtikaa siitä, että riittävä jäähdytysilma pääsee vapaasti kiertämään laitteen sisällä. Älkää asentako ja/tai käytäkö valvojaa tiloissa, joissa se joutuu alttiiksi ympäristötekijöille (sade, jää, lumi), pölylle, syövyttävälle kaasulle, räjähdysalttiissa ympäristössä tai tiloissa, joissa paloriski on suuri.

Toiminnan aikana tulee noudattaa seuraavia ympäristönoloja koskevia sääntöjä:

- lämpötila: 5 °C ja +45 ° välillä
- suhteellinen kosteus: 0 - 95% välillä (ilman lauhdetta).

Muiden kytkentöjen ja valinnaisten lisälaitteiden asennusten suorittamiseksi, katsokaa kappaletta "Technical Information".

## KÄYTTÖ

Tähän kappaleeseen on kirjattu tärkeimmät käyttötoimenpiteet. Tarkempia lisätietoja sekä kytkentöjä, että valinnaisia lisälaitteita koskevien toimenpiteiden suorittamista käsittäviä tietoja löydätte kappaleesta "USE", joka on "Technical Information"-kappaleen liitteenä.

Ennen valvojan käyttöä suorittaakaa kaikki sähkökytkennät seuraten kytkettävän pumpun käyttöohjeita.

**VAARA!**

Mikäli pumppu on asetettu pöydälle, varmistakaa että se on vakaa. Näin vältetään vammoilta ihmisille sekä itse koneelle. Älkää myöskään käyttäkö pumppua, mikäli sisääntulon laippaa ei ole kytketty järjestelmään tai mikäli sitä ei ole suljettu laippasulkijalla.

**HUOM**

Sulkimen J1 liitin tulee jättää yhdyskaapelilla kytkettynä, mikäli ulkoisia kytkentöjä ei suoriteta. Esityhjennyspumppu ja Turbo-V pumppu voidaan käynnistää samanaikaisesti.

**Valvojan säätimet, osoittimet ja liittimet**

Seuraavassa on kuvattu valvojan etu- ja takapaneelit. Tarkempia lisätietoja saatte kappaleesta "Technical Information".

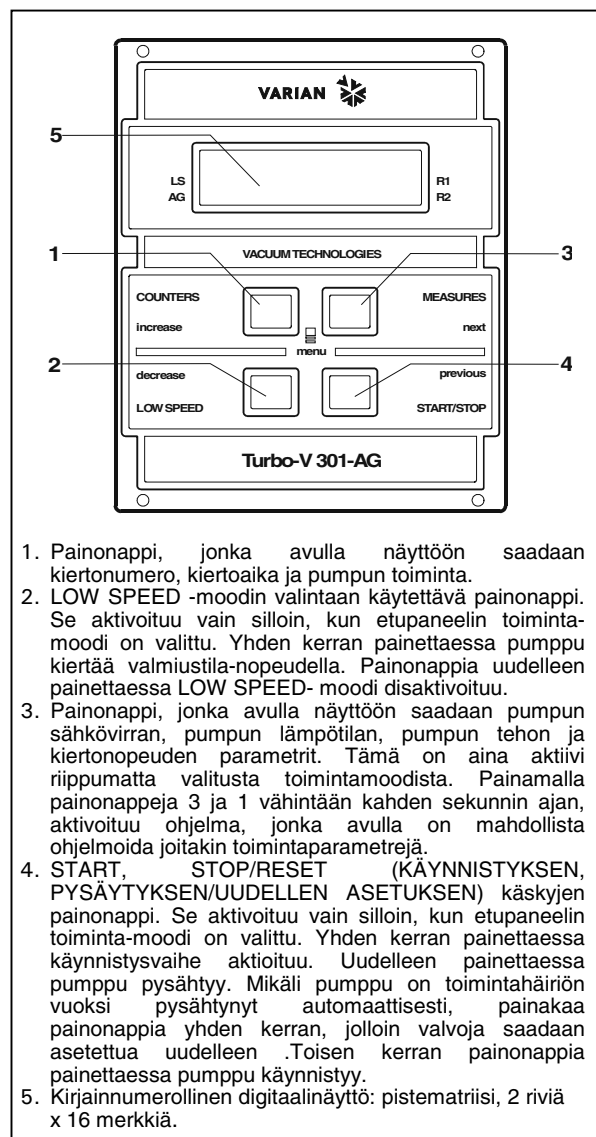
**Etupaneelin kuvaus**

1. Painonappi, jonka avulla näyttöön saadaan kiertonumero, kiertoaika ja pumpun toiminta.
2. LOW SPEED -moodin valintaan käytettävä painonappi. Se aktivoituu vain silloin, kun etupaneelin toimintamoodi on valittu. Yhden kerran painettaessa pumppu kiertää valmiustila-nopeudella. Painonappia uudelleen painettaessa LOW SPEED- moodi disaktivoituu.
3. Painonappi, jonka avulla näyttöön saadaan pumpun sähkövirran, pumpun lämpötilan, pumpun tehon ja kiertonopeuden parametrit. Tämä on aina aktiivi riippumatta valitusta toimintamoodista. Painamalla painonappeja 3 ja 1 vähintään kahden sekunnin ajan, aktivoituu ohjelma, jonka avulla on mahdollista ohjelmoida joitakin toimintaparametrejä.
4. START, STOP/RESET (KÄYNNISTYKSEN, PYSÄYTYKSEN/UUELLEN ASETUKSEN) käskyjen painonappi. Se aktivoituu vain silloin, kun etupaneelin toiminta-moodi on valittu. Yhden kerran painettaessa käynnistysvaihe aktivoituu. Uudelleen painettaessa pumppu pysähtyy. Mikäli pumppu on toimintahäiriön vuoksi pysähtynyt automaattisesti, painakaa painonappia yhden kerran, jolloin valvoja saadaan asetettua uudelleen. Toisen kerran painonappia painettaessa pumppu käynnistyy.
5. Kirjainnumerollinen digitaalinäyttö: pistematriisi, 2 riviä x 16 merkkiä.

Valvojen Turbo-V 301-AG etupaneelit

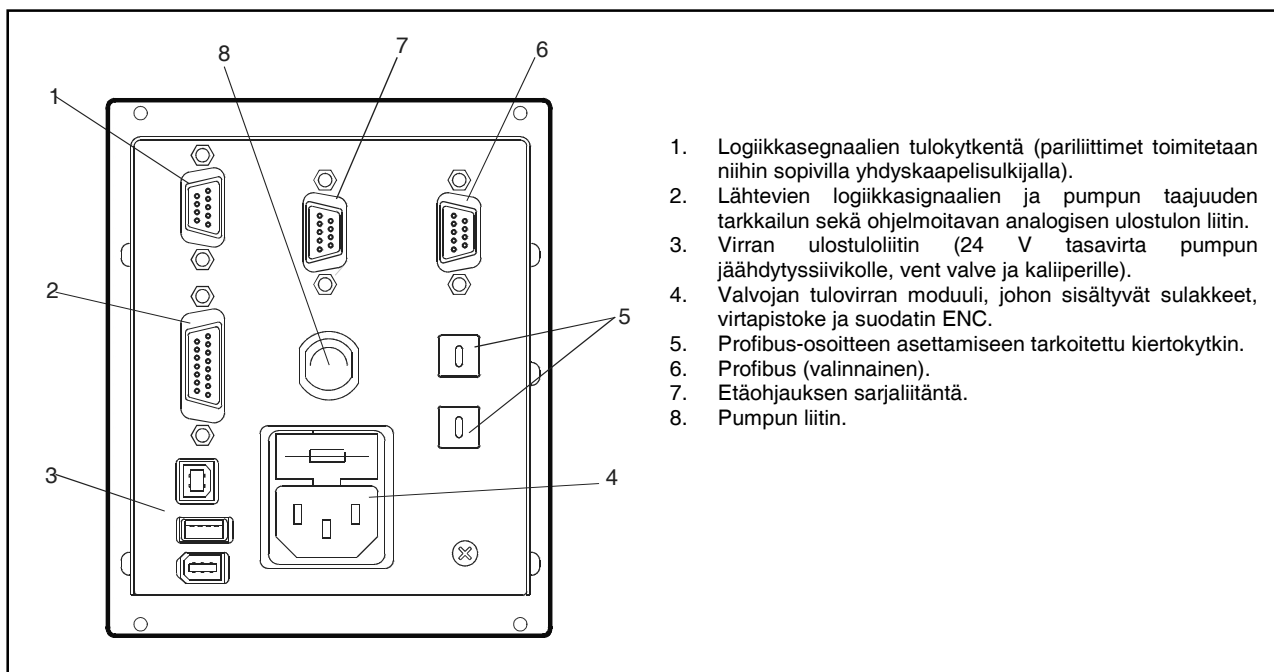

Valvojen Turbo-V 301-AG takapaneli

## KÄYTTÖTOIMENPITEET

### Valvojan päälle pano

Valvoja käynnistyy asettamalla virtakaapeli pistorasiaan.

### Pumpun käynnistys

Käynnistäksenne pumpun pitää ottaa käyttöön interlock-sisääntulo ja painaa etupaneelin painiketta START.

### Pumpun pysäyttäminen

Pumppu pysähtyy painamalla etupanelissa olevaa STOP painonappia.

## HUOLTO

Turbo-V 301 Rack sarjan valvojat eivät kaipaakaan minkäänlaista huoltoa. Mahdolliset valvojaan tehtävät toimenpiteet tulee jättää aina valtuutetun henkilön tehtäväksi.

Toimintahäiriön sattuessa on mahdollista käyttää Varianin korjauspalvelua tai "Varian advance exchange service" -palvelua, jolloin on mahdollista vaihtaa rikkiönyt valvoja ladattuun valvojaan.



**VAARA!**

Ennen minkätähansa valvojaan tehtävän toimenpiteen suorittamista irroittakaa sähkökaapeli pistorasiasta.

Mikäli valvoja täytyy romuttaa, toimikaa sen hävittämisessä kansallisten säädösten ja normien määräävällä tavalla.

## HÄVITTÄMINEN

**Pakkausmerkinnöissä olevan WEEE-logon merkitys** Alla näkyvä merkki on lisätty pakkaukseen EY:n ns. WEEE-direktiivin mukaisesti.

Merkki (**koskee ainoastaan Euroopan Unionin jäsenmaita**) tarkoittaa, että tuotetta EI saa hävittää tavallisen kotitalous- tai teollisuusjätteen mukana, vaan se on toimitettava erilliseen keräyspisteeseen. Loppukäyttäjää kehoitetaan sen vuoksi ottamaan keräys- ja hävittämisprosessia varten yhteyttä laitteen toimittajaan, olipa se sitten laitteen valmistaja tai jälleenmyyjä, tarkastettuaan ensin kaupan sopimusehdot.

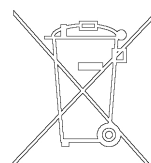

## VIANETSINTÄ

Joidenkin toimintahäiriöiden yhteydessä valvojan itsemäärätelypiiri analysoi virheen, joka näkyy viesteinä, jotka on kuvailtu seuraavassa taulukossa.

VIESTI	VIKA	KORJAUSTOIMENPITEET
<b>CHECK CONNECTION TO PUMP</b>	Toimintahäiriö pumpun ja valvojan liittännässä. Tai Pumpun lämpötila on alempi kuin 0 °C.	Tarkistakaa että pumpun ja valvojan välinen yhteyskaapeli on hyvin kiinnitetty päistään eikä sen varrella ole esteitä. Painakaa kaksi kertaa painonappia START jolloin pumppu käynnistyy.
<b>WAITING INTERLOCK</b>	Lukitusignaali (interlock) liittimessä P1 on aktiivinen johtuen liittimen J1 neulojen 3 ja 8 välillä tapahtuneen oikosulun keskeytyksestä tai ulkoisen lukitusignaalin (interlock) avautumisesta.	Palauttakaa liittimen J1 neulojen 3 ja 8 välinen oikosulku tai sulkekaa ulkopuolinen lukitusignaali (interlock).
<b>PUMP OVERTEMP.</b>	Ylemmän laakerin tai pumpun lämpötila on ylittänyt 60 °C.	Odottakaa että lämpötila putoaa kynnysarvon alapuolelle. Painakaa painonappia START kaksi kertaa jolloin pumppu käynnistyy.
<b>CONTROLLER OVERTEMP.</b>	Valvojan muuntajan lämpötila on 70 °C. Tai Valvojan lämmittimen lämpötila on korkeampi kuin 60 °C.	Odottakaa, että lämpötila putoaa kynnysarvon alapuolelle. Painakaa painonappia START kaksi kertaa jolloin pumppu käynnistyy.
<b>TOO HIGH LOAD</b>	Pumpun absorptiovirta ylittää ohjelmoidun arvon.	Tarkistakaa, että pumpun roottori pyörii vapaasti. Painakaa painonappia START kaksi kertaa jolloin pumppu käynnistyy.
<b>SHORT CIRCUIT</b>	Normaalityöskentelyn aikana (käynnistyksen jälkeen) poistoliitin on oikosulussa.	Tarkistakaa pumpun ja valvojan välinen liitos. Painakaa painonappia START kaksi kertaa jolloin pumppu käynnistyy.
<b>SYSTEM OVERRIDE</b>	Kaukokytkimestä tuleva hälytyssignaali on pysäyttänyt pumpun.	Irroitakaa valvojan sähkökaapeli verkkovirrasta ja korjatkaa hälytyksen aiheuttaja. Kytkekää sähkökaapeli uudelleen ja painakaa painonappia START kaksi kertaa jolloin pumppu käynnistyy.
<b>OVERVOLTAGE</b>	Valvojan sähkövirran syötössä on ilmennyt ongelma tai valvojan saama signaali on väärä.	Painakaa painonappia START kaksi kertaa, jolloin pumppu käynnistyy. Mikäli viesti näkyy uudelleen kääntykää Varian huoltopalvelun puoleen.
<b>POWER FAIL</b>	Vika pumpun, valvojan virransyöttöosassa.	Kääntykää Varian-yhtiön puoleen Huoltoa tarvittaessa.

**ΓΕΝΙΚΕΣ ΠΛΗΡΟΦΟΡΙΕΣ**

Αυτή η συσκευή προορίζεται για επαγγελματική χρήση. Ο χρήστης θα πρέπει να διαβάσει προσεκτικά τη οδηγία του παρόντος εγχειριδίου και οποιαδήποτε άλλη προσθετη πληροφορία που παρέχεται από τη Varian, πριν από τη χρησιμοποιήση της συσκευής. Η Varian δεν φέρει καμία ευθύνη όσον αφορά την ολική ή μερική αθώαση των οδηγών, την ακαταλληλή χρήση εκ μερικής ανεκπαίδευτου προσωπικού, αυθαιρέτη επεμβάση ή χρήση που δεν συμφωνεί με τη ειδική εθνική διατάξη. Ο ρυθμιστή της σειράς Turbo-V 301 Rack είναι εναή μετατροπή συχνότητ, ελεγχόμεν ή από έναν μικροεξεργαστή, πραγματοποιημεν ή από εξαρτήματα σε στερεά και αυτοπροστατευτικά ικανότητα.

Χαρακτηριστικά του controller:

- Ενεργεια μεταπία / εξ αποστασσή/ Σειριακή
- Πιλοταρισμα με 24 Vdc του στροβίλου ψυξή αντλία
- Πιλοταρισμα vent valve
- Αναγνώση ταχυατητ αντλία κατώπ τη εντολή σταση (Αναγνώση ταχυατητ σταση)
- Αναγνώση πιεση
- Διασυνδση Profibus (προαιρετικό)
- Αυτοματη ρυθμισή ταση εισόδου.

Στη επομενή παραγραφή αναφέρονται οαλή οι απαραίτητή πληροφορία που εγγυονται την ασφαλή του χειριστή κατά τη διάρκεια τη χρησιμοποιή τη συσκευή. Λεπτομερή πληροφορία παρέχονται στο παραρτήμα "Technical Information".

**Αυτο το εγχειριδιο χρησιμοποιεί τη ακολουθή συμβασηή**

**ΚΙΝΔΥΝΟΣ**

Οι ενδειξή κινδύνου προσελκυουν την προσχή του χειριστή σε μια διαδικασία ή σε μια ειδική εργασία η οποία εάν δεν εκτελεστεί σωστά, θα μπορούσε να προκαλέσει σοβαρή προσωπική βλάβη.

**ΠΡΟΣΟΧΗ**

Οι ενδειξή προσχηή εμφανίζονται πριν από τη διαδικασία ή οι οποί ή εάν δεν εκτελεστούν με προσχή, θα μπορούσαν να προκαλέσουν ζημιαή στη συσκευή.

**ΣΗΜΕΙΩΣΗ**

Οι σημειώση περιέχουν σημαντική πληροφορία που έχουν αποσπαστεί από το κείμενο.

**ΑΠΟΘΗΚΕΥΣΗ**

Κατά τη διάρκεια τη μεταφορά ή και τη αποθήκευσή των ρυθμιστών πρέπει να τηρούνται οι ακολουθή περιβαλλοντική συνθήκη:

- θερμοκρασία: -20 °C εαή +70 °C
- σχετική υγρασία 0 - 95% (ασυμπακνωτή)

**ΠΡΟΕΤΟΙΜΑΣΙΑ ΓΙΑ ΤΗΝ ΕΓΚΑΤΑΣΤΑΣΗ**

Ο ρυθμιστή προμηθεύεται σε μια ειδική προστατευτική συσκευασία. Αν υπάρχουν ενδειξή βλάβη που θα μπορούσαν να έχουν προκληθεί κατά τη διάρκεια τη μεταφορά ή, ερχεστε σε επαφή με το τοπικό τμήμα πωλήσεων.

Κατά τη διάρκεια του ανοιγματοή τη συσκευασιαή, δώστε ιδιαίτερη προσχή εαί ωστε να μην περσει και να μην χτυπηθεί ο ρυθμιστή.

Μην εγκαταλείπετε τη συσκευασία στο περιβάλλον. Το υλικό ανακυκλώνεται πλήρ ή και ανταποκρίνεται στην Οδηγία τη Ε.Ε. 85/399 για την διαφύλαξη του περιβαλλοντή.

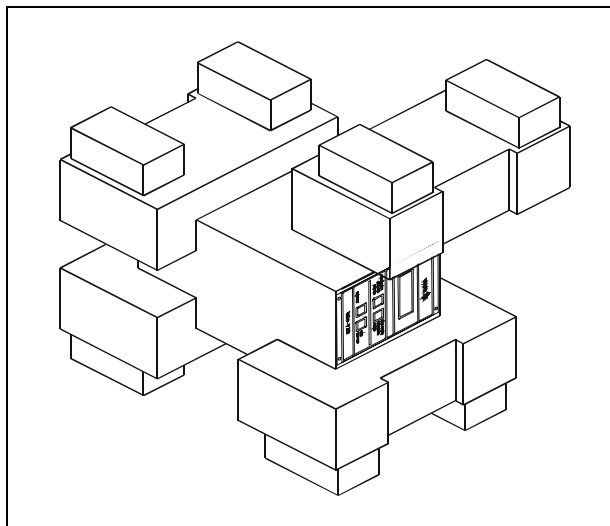

Συσκευασία των ρυθμιστών

**ΕΓΚΑΤΑΣΤΑΣΗ**



Ο ρυθμιστήρι είναι εφοδιασμενός με τριπολικό καλωδιό τροφοδοσιαή (βλεπε πινακά μερών για τα οποία μπορεί να γίνει παραγγελια) με μια πιαζα που ερχει εγκριθεια διεθνωή οαο αφορα την ασφαλεια του καταλωτηα. Να χρησιμοποιεατε παρντα αυτα το καλωδιό τροφοδοσιαή και να το βιαζετε σε πιαζα που να διαθεαται την καταλληλη γειωση εατσι ωαοτε να αποφευγονται ηλεκτρικεαή εκκενωασειή και να τηρουανται οι οδηγιαή Ε.Ε. Στο εσωτερικό του ρυθμιστηα αναπτυσσονται υψηλεαή τασειή που μπορούν να προκαλεασουν σοβαρουαή τραυματισμουαή ηα και το θανατο. Πριν εκτελεασετε οποιαδηποτε εργασιαα εγκαταασασηή ηα συντηρησηή του ρυθμιστηα αποσυνδεατε τον αποα την πιαζα τροφοδοσιαή.

**ΣΗΜΕΙΩΣΗ**

Ο ρυθμιστήρι μπορεί να τοποθετηθει επανω σε να τραπεζι ηα στο εσωτερικό μιαή καταλληληή θηακηή. Σε οποιαδηποτε περιπαση είναι αναγκαίο ο αεραή να κυκλοφορεια ελευθερα γυρω αποα το συαστημα. Μην τοποθετειατε καια - ηα χρησιμοποιεατε τον ρυθμιστηα σε χωαρουή εκτεθειμενουή στη καρικεαή συνθηακηή (βροχηα, παγγοή, χιοανι), σκοανεή, πολεμικαα αεαρια, σε χωαρουή οαπου υπααρχει κινδύνοή εκρηξηή ηα πυρκαγιααή.

Κατα τη διαρκεια τηή λειτουργιαή πρεαπει απαιρηατηαή να τηρουανται οι ακοαλουθεή περιβαλλοντικεαή συνθηακηή

- θερμοκρασιαα: 5 °C εαωή + 45 °C
- σχετικα υγρασιαα: 0 - 95% (ασυμπυακνωτη).

Για τη αλληλή συνδεασειή και για την εγκαταασαση των επιπλεον εξαρτηματων, βλεαπε το παρααρηα “Technical Information”.

**ΧΡΗΣΗ**

Σ’ αυτηαν την παρααρηα αναφεαρονται οι κυριοατερεή διαδικασιααή λειτουργιααή. Για περισσοατερεή λεπτομεαρειή και για διαδικασιααή που απαιτουαν ιδιαατερεή συνδεασειή ηα αξεσουαα, αναφερθειατε στη παρααρηα οΰΧρηασηΰ του Παραρηαματοή “Technical Information”. Πριν χρησιμοποιηατε τον ρυθμιστηα καιατε οαληή τηή ηλεκτρικεαή και πνευματικεαή συνδεασειή και αναφερθειατε στο εγχειαδιο τηή συνδεμεανηή αντλιααή.



**ΚΙΝΔΥΝΟΣ**

Για να αποφυαγετε βλαβηή σε αατομα ηα στη συακεια, σε περιπαση που η αντλια είναι τοποθετημενη σε εανω τραπεζι σγυρευτειατε οατι είναι καλα σταθεροποιημενη. Μην θεατε σε λειτουργια την αντλια αν η φλαατζα εισοαδου δεν είναι συνδεμεανη στο συαστημα ηα αν δεν είναι κλειστη με την φλαατζα κλεισιαατοή.

**ΣΗΜΕΙΩΣΗ**

Το βυαομα κλεισιαατοή J1 θα πρεαπει να αφεθεια συνδεμεανο με τη γεαφυραή του αν δεν πραγματοποιεαται καια εξωτερικη συνδεαση. Η αντλια προ-κενουα και η αντλια Turbo-V μπορούν να ενεργοποιηθουαν προσωαριαα.

**Χειριστήρια, δειακτηή και βυαομαα του Ρυθμιστήρι**

Παρακαατω παρουσιααζεται ο εμπροαοθηή και οπισθηή πινακαή του controller. Για περισσοατερεή λεπτομεαρειή αναφερθειατε στο παρααρηα “Technical Information”.

**Περιαρηα εμπροαοθηου πινακα**

The diagram shows the front panel of the Turbo-V 301-AG controller. At the top is the VARIAN logo. Below it are two digital displays labeled LS/AG and R1/R2. The central section contains four buttons: 'increase' and 'next' on the top row, and 'decrease' and 'previous' on the bottom row. A 'menu' button is located between the two rows. Below these buttons is a 'LOW SPEED' indicator and a 'START/STOP' button. The bottom of the panel features the 'Turbo-V 301-AG' branding. Five numbered callouts point to specific features: 1 points to the 'LOW SPEED' button, 2 points to the 'increase' button, 3 points to the 'next' button, 4 points to the 'previous' button, and 5 points to the top digital display area.

1. Κουμπια για να εμφανιστουαν στη οθονη οι παραμετροι cycle number, cycle time, pump life.
2. Κουμπια για την επιλογη του τροπου LOW SPEED (χαμηλη ταχυατηα). Ενεργοποιεαται μονον οαταν ερχει επιλεγεια ο τροποή χρησιμουα στον μπροατινο πινακα. Πατωαντασ το μια φορα, η αντλια περιστροφεται με ταχυατηα “stand-by”. Πατωανταή το ακοαμη μια φορα σταμαατα η λειτουργια του LOW SPEED.
3. Κουμπια για την εμφανιση στη οθονη των παραμετων pump current, pump temperature, pump power και rotational speed. Είναι παρντα ενεργοποιημεαο αααχεα με τον τροπο λειτουργιαή που ερχει επιλεγεια. Πατωανταή τα κουμπια 3 και 1 για τουααχιστον 2 δευτεροαλεπα ενεργοποιεαται εαα προααρηα με το οποιο μπορείατε να προααμαατιαατε μερικεαή λειτουργικεαή παραμεατρουή.
4. Κουμπια για τουή χρησιμουαή START, STOP/RESET. Είναι ενεργα μονον οαταν ερχει επιλεγεια η λειτουργια στον μπροατινο πινακα. Πατωανταή το μια φορα ενεργοποιεαται η φαση εκκιανησηή. Πατωανταή το ακοαμη μια φορα σταμαατα η αντλια. Αν η αντλια σταμαατησε αυτοααα λοαγω βλαβηή θα πρεαπει να πατηθεια αυτοα το κουμπια μια φορα εατσι ωαοτε να γίνει η επαναρυσθηα (reset) του ρυθμιστηα και μια δευατερη φορα για να ενεργοποιηθει η αντλια.
5. Αλαριθμητικη οθονη με υγραν κρυστααλλονη μηατρα κουκιαδων, 2 σειρεαή x 16 χαρακτηαρηή.

Εμπροαοθηή πινακαή του Ρυθμιστήρι Turbo-V 301-AG



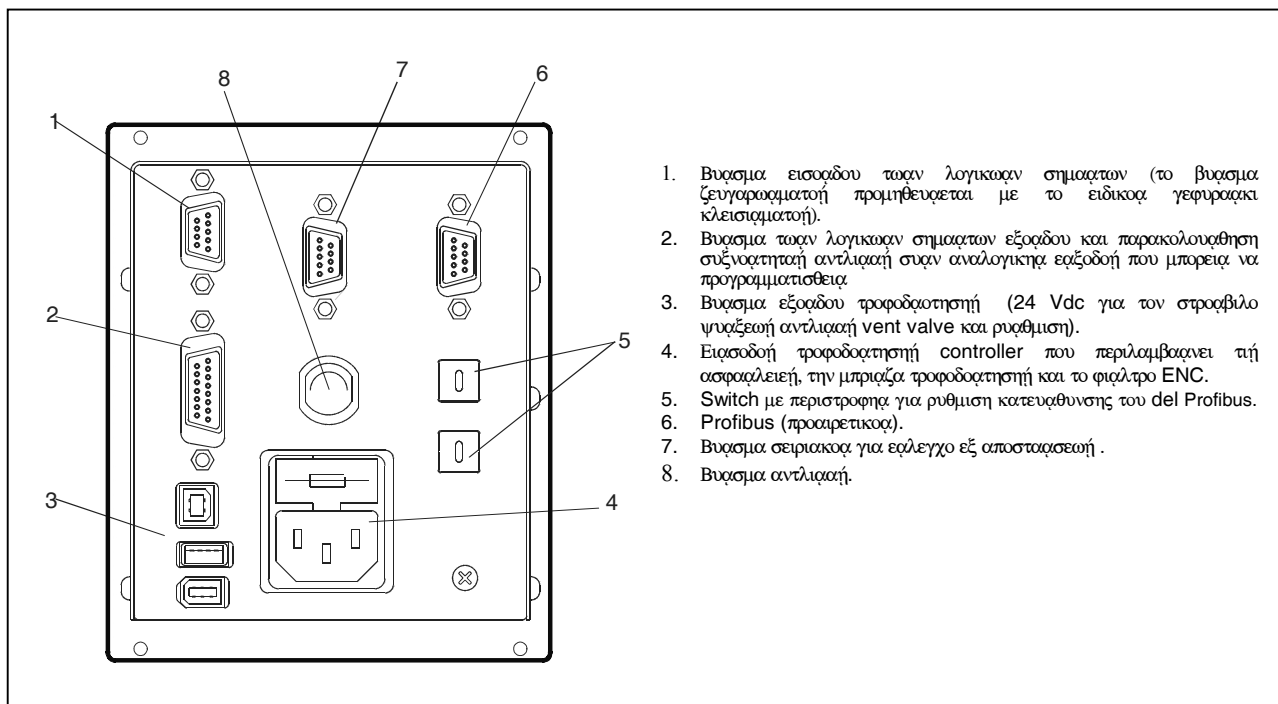

1. Βυσμα εισοδου των λογικων σηματων (το βυσμα ζευγαρωματοή προμηθευεται με το ειδικο γεφυρακι κλεισιματοή).
2. Βυσμα των λογικων σηματων εξοδου και παρακολουθηση συζωατηαή αντλιααή σφων αναλογικηα εξωδοή που μπορεί να προγραμματισθαι.
3. Βυσμα εξοδου τροφοδοτησής (24 Vdc για τον σφωβιλο ψωαζωαή αντλιααή vent valve και ρωθμιση).
4. Εισωδοή τροφοδοτησής controller που περιλαμβανει τη ασφαλειη, την μπριαζα τροφοδοτησής και το φιαλτρο ENC.
5. Switch με περισφωρα για ρωθμιση κατευαθυνσης του del Profibus.
6. Profibus (προαιρετικοα).
7. Βυσμα σειριακοα για εαλεγχο εξ αποσταασειαή .
8. Βυσμα αντλιααή.

Εμπρωσθιοή πιανακαή του Ρωθμιστηα Turbo-V 301-AG

## ΔΙΑΔΙΚΑΣΙΕΣ ΧΡΗΣΗΣ

### αΑναμμα του Ρωθμιστηα

Για να αναμνει ο ρωθμιστηα είναι αρκετοα να βααλετε το καλωαδιο τροφοδοσιααή στην πριαζα του δικτυαου.

### Εκκριανηση τηή Αντλιααή

Για την εκκριανηση τηή αντλιααή ενεργοποιιαστε την εισωδο interlock και πατηρασε το κουμπια START του εμπρωσθιου πιανακα.

### Σταωση τηή Αντλιααή

Για να σταματηρασει η αντλιαα αρακεια να πατηρασε το κουμπια STOP του εμπρωσθιου πιανακα.

## ΣΥΝΤΗΡΗΣΗ

Οι ρωθμιστηα τηή σειρααή Turbo-V 301 δεν απαιτουα καμια συντηραρηση. Οποιαδηαποτε εαεαμβαση θα πρεαπει να πριαγατωποηθαι αποα εξωσυοδοτημεαο προσωπικοα.

Σε περιαπτωση βλααβηή μπορείατε να χρησημοποιιαρασε την υπηρεσια επισκευαων τηή Varian ηα το "Varian advance exchange service", που σαή διανει τη δυνατωατητα να εααετε εααν αναζωογονημεαο ρωθμιστηα σε αντικαταρασταση του ααλασμεαου.



**ΚΙΝΔΥΝΟΣ**

Πριν κααεντε οποιαδηαποτε εαεαμβαση στον Ρωθμιστηα αποσυαδερασε το καλωαδιο τροφοδοσιααή.

Για τη διααλυση του ρωθμιστηα τηραρασε τηή ισχυαουσειή εθνικααή διατααξειή.

## Χώνευση

Ένωια του logo "WEEE" που υπάρχει στις ετικέτες. Το παρακάτω σύμβολο εφαρμζεται σύμφωνα με την ντριακτίβα Ε.Κ. που ονομάζεται "WEEE".

Αυτό το σύμβολο (που ισχύει μόνο για τις χώρες της Ευρωπαϊκής Κοινότητας) δείχνει ότι το προϊόν στο οποίο είναι εφαρμσμένο, ΔΕΝ πρέπει να πεταχτεί μαζί με κοινά οικιακά ή βιομηχανικά σκουπίδια, αλλά με διαφωροποιημένο τρόπο.

Γ'αυτό, παρακαλούμε τον τελικό χρήστη να έρθει σε επαφή με τον πωλητή της συσκευής ή με το εργοστάσιο σχετικά με την εκκίνηση της διαδικασίας διαφωροποιημένης συλλογής, κατόπιν επαλήθευσης του συμβολαίου πώλησης.

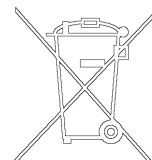

## ΜΗΝΥΜΑΤΑ ΛΑΘΟΥΣ

Σε ορισμενές περιπτώσεις βλάβης τα κυκλώματα αυτοδιαγνωσής του ρυθμιστή παρουσιάζουν ορισμένα μηνύματα λάθους τα οποία παρουσιάζονται στον πίνακα που ακολουθεί.

ΜΗΝΥΜΑ	ΠΕΡΙΓΡΑΦΗ	ΔΙΟΡΘΩΣΗ
<b>CHECK CONNECTION TO PUMP</b>	Κακή λειτουργία στη συνδεση αντλιας και ρυθμιστη. Η/α Η θερμοκρασια τη/η αντλια/ή είναι/αι κατω/ατερη απο/α 0 °C.	Ελεαγγετε αν το καλωαδιο συνανδεση/η μεταξυ/α αντλια/ή και ρυθμιστη/α είναι/αι καλα/α σταθεροποιημενο και στα δυαο ακρα/α και οα/ατι δεν υπααρχει διακοπη/α. Πατηαστε δυαο φορα/η το κουμπια/α START για να θεαστε/α ξανα/α σε κια/ανηση την Αντλια/α.
<b>WAITING INTERLOCK</b>	α/Εχει ενεργοποιηθει/α το σηα/α interlock που βρια/ασκετε στο βυα/ασμα P1 λογα/α διακοπη/η του βρα/αχυκυκλωα/ατο/η μεταξυ/α του pin 3 και του pin 8 του βυα/ασματο/η J1, η/α λογα/α ανοιγα/ατο/η του σηα/ατο/η του εξωτε/αρικου/α interlock.	Επα/ναφερα/ατε το βρα/αχυκυκλωα/α μεταξυ/α του pin 3 και του pin 8 του βυα/ασματο/η J1, η/α κλια/αστε το σηα/α του εξωτε/αρικου/α interlock.
<b>PUMP OVERTEMP.</b>	Η θερμοκρασια του α/ανω κουζι/ανεα/ατου τη/η αντλια/ή ξε/απερα/ασε του/η 60 °C.	Περ/αμενα/ατε α/ασπου η θερμοκρασια να κα/ατεβει/α κατω/α απο/α το α/ανωα/ατο επιτρε/ατο σημεια/ο.  Πατηαστε δυαο φορα/η το κουμπια/α START για να θεαστε/α ξανα/α σε κια/ανηση την Αντλια/α.
<b>CONTROLLER OVERTEMP.</b>	Η θερμοκρασια του μετα/ασηα/ατιστη/α του/η 70 °C. Η/α Η θερμοκρασια του ψυ/ακτη του controller ξε/απερα/ασε του/η 60 °C.	Περ/αμενα/ατε α/ασπου η θερμοκρασια να κα/ατεβει/α κατω/α απο/α το α/ανωα/ατο επιτρε/ατο σημεια/ο.  Πατηαστε δυαο φορα/η το κουμπια/α START για να θεαστε/α ξανα/α σε κια/ανηση την Αντλια/α.
<b>TOO HIGH LOAD</b>	Κατω/α την κανονικη/α λειτουργια/α (μετα/α τη φα/αση εκκια/ανηση/η) το α/απορο/αφουα/αμενο ρε/αυμα απο/α την αντλια/α είναι/αι μεγα/αλυα/ατερο απο/α το προγα/αμματισμε/ανο.	Ελεαγγετε αν ο ροα/ατορα/η τη/η αντλια/ή μπο/αρει να πε/αστρα/αφει/α ελευα/αθερα/α.  Πατηαστε δυαο φορα/η το κουμπια/α START για να θεαστε/α ξανα/α σε κια/ανηση την Αντλια/α.
<b>SHORT CIRCUIT</b>	Κατω/α την κανονικη/α λειτουργια/α (μετα/α τη φα/αση εκκια/ανηση/η) η συνανδεση εξο/αδου εα/αχει βρα/αχυκυκλωα/ασει.	Ελεαγγετε τη/η συνδεα/ασει/η μεταξυ/α αντλια/ή και ρυθμιστη/α.  Πατηαστε δυαο φορα/η το κουμπια/α START για να θεαστε/α ξανα/α σε κια/ανηση την Αντλια/α.
<b>SYSTEM OVERRIDE</b>	Η αντλια/α στα/αμαα/ατησε απο/α ε/ανα σηα/αμα κινδυ/ανου που προεα/αρχεται απο/α την μα/ακρινη/α επα/αφη/α.	Βγα/αλτε το καλωαδιο τρο/αφοδοσια/η του ρυθμιστη/α και διο/αρθωα/αστε την αιτια/α προα/ακληση/η του σηα/αματο/η κινδυ/ανου.  Επα/νασυνδεα/αστε το καλωαδιο τρο/αφοδοσια/η και πατηαστε δυαο φορα/η το κουμπια/α START για να θεαστε/α ξανα/α σε κια/ανηση την αντλια/α.
<b>OVERVOLTAGE</b>	Πα/αρουσια/αστηκε βλα/αβη στο/αν τομεια/α τρο/αφοδοσια/η του ρυθμιστη/α η/α ο ρυθμιστη/α/η δεα/αχθη/ακε ε/ανα λα/ανθασμε/ανο σηα/αμα.	Πατηαστε δυαο φορα/η το κουμπια/α START για να θεαστε/α ξανα/α σε εκκια/ανηση την αντλια/α.  Αν ξανα/απα/αρουσια/ασει/α το μηνυ/αμα απευθ/ανθει/ατε στην Varian για συντη/αρηση.
<b>POWER FAIL</b>	Βλα/αβη στο/αν τομεια/α τρο/αφοδοα/ατηση/η τη/η αντλια/ή, του controller.	Απευθ/ανθει/ατε στην Varian για συντη/αρηση.

## ÁLTALÁNOS INFORMÁCIÓK

Ez a berendezés hivatásos használatra tervezett. A felhasználónak, a berendezés használatát megelőzően, gondosan el kell olvasnia e felhasználói kézikönyvet és minden egyéb, a Varian által szolgáltatott információt. A Varian elhárít magától minden esetleges felelősséget, mely a felhasználói utasítások teljes vagy részleges figyelmen kívül hagyásához, a nem kiképzett személyzet által történő nem megfelelő használathoz, meghatalmazás nélküli beavatkozásokhoz, vagy a specifikus nemzeti irányelvekkel ellentétes használathoz kötődik.

A Turbo-V 301 Rack sorozatú vezérlők mikroprocesszoros vezérlésű, szilárdtest-elemekkel realizált frekvencia-átalakítók, öndiagnosztikai és saját védelmi képességekkel.

### A vezérlő tulajdonságai:

- Előlapról történő / táv- / soros vonalon keresztüli működtetés
- A szivattyú hűtőventillátorának 24 Vdc feszültségen történő vezérlése
- A vent valve vezérlése
- A szivattyú sebességének leolvasása a leállítási parancsot követően (leállási sebesség leolvasása)
- A nyomásérték leolvasása
- Profibus illesztő (opcionális)
- A bemeneti feszültség automatikus beállítása.

Az elkövetkező szakaszok tartalmazzák mindazokat az ismereteket, melyek a kezelő biztonságát hivatottak garantálni a berendezés használata során. Részletes információk találhatóak a "Technical Information" című mellékletben.

**E kézikönyv az alábbi megegyezészerű jelöléseket alkalmazza:**



**VESZÉLY!**

A veszélyt jelző üzenetek olyan eljárásra vagy specifikus tevékenységre hívják fel a kezelő figyelmét, melyek, ha nem megfelelő módon kerülnek végrehajtásra, súlyos személyi sérüléseket okozhatnak.



**FIGYELEM!**

A figyelmeztető üzenetek azon eljárások előtt kerülnek megjelenítésre, melyek figyelmen kívül hagyása a berendezés károsodásához vezethet.

### MEGJEGYZÉS

*A megjegyzések fontos, a szövegből kivonatolt információkat tartalmaznak.*

## TÁROLÁS

A vezérlők szállítása és tárolása során az alábbi környezeti feltételeket kell biztosítani:

- hőmérséklet: -20 °C és +70 °C között
- relatív nedvességtartalom: 0 - 95% (nem lecsapódó)

## A TELEPÍTÉSRE VALÓ ELŐKÉSZÍTÉS

A vezérlő speciális védőcsomagolásban kerül leszállításra; ha ez károsodás jeleit mutatja, melyek a szállítás során keletkezettek, kapcsolatba kell lépni a helyi forgalmazó irodával.

A kicsomagolás során különleges figyelmet kell fordítani arra, hogy a vezérlő le ne essék, és ne szenvedjen ütődéseket.

A csomagolóanyagot nem szabad szétszórni a környezetben. Az anyag teljes mértékben újrafelhasználható, s megfelel a környezetvédelemmel kapcsolatos EGK 85/399-es irányelvnek.

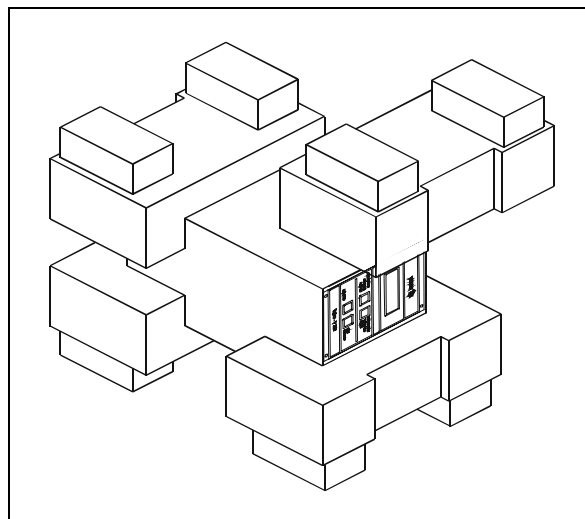

számú vezérlők csomagolása

## TELEPÍTÉS



**VESZÉLY!**

A vezérlő nemzetközileg jóváhagyott csatlakozódugóval ellátott, háromerű hálózati kábellel kell, hogy táplálva legyen (a rendelhető alkatrészeket lásd a táblázatban). Mindig ezt a hálózati kábelt kell használni, s a csatlakozódugót megfelelő földcsatlakozóval ellátott aljzatba illeszteni, az elektromos kisülések elkerülése és az EK előírásainak a tiszteletben tartása érdekében.

A vezérlő belsejében nagyfeszültségek alakulnak ki, melyek súlyos károkat vagy halált okozhatnak. A vezérlő bármely telepítési vagy karbantartási műveletének megkezdése előtt ki kell húzni a hálózati csatlakozót.

### MEGJEGYZÉS

A vezérlő telepítésre kerülhet egy asztalon, vagy egy megfelelő rack belsejében. Minden esetben szükséges azonban, hogy a hűtőlevegő szabadon áramolhasson a berendezés belsejében. A vezérlőt nem szabad légköri hatásoknak (eső, fagy, hó) kitett, poros, maró hatású gázt tartalmazó, robbanás- vagy fokozottan tűzveszélyes környezetben telepíteni és/vagy használni.

Üzem közben az alábbi környezeti feltételeket kell biztosítani:

- hőmérséklet: 5 °C és +45 °C között
- relatív nedvességtartalom: 0 - 95% (nem lecsapódó).

A többi összekötéssel és az opcionális kiegészítő felszerelések telepítésével kapcsolatosan lásd a "Technical Information" című alfejezetet.

## HASZNÁLAT

Ebben a szakaszban a fontosabb működési eljárások kerülnek ismertetésre. További részletek és az összekötéseket vagy az opcionális elemeket érintő eljárások találhatóak a "Technical Information" melléklet "Use" című szakaszában.

A vezérlő használata előtt valamennyi elektromos és pneumatikus összeköttetést létre kell hozni, és figyelembe kell venni a csatlakoztatott szivattyú kézikönyvét.



**VESZÉLY!**

Abban az esetben, ha a szivattyú egy asztalon került elhelyezésre, a személyekben és a berendezésben való károk elkerülése érdekében, biztosítani kell az asztal stabilitását. Soha nem szabad a szivattyút a bementi peremnek a rendszerhez való csatlakoztatása, vagy a záró peremmel való lezárása nélkül üzemeltetni.

### MEGJEGYZÉS

A J1 lezáró csatlakozó össze kell maradjon kötve a megfelelő átkötéssel (jumper), ha nincs semmiféle külső összeköttetés. Az elő-vákuum és a Turbo\_V szivattyú egyidejűleg is be lehetnek kapcsolva.

### A vezérlő parancsai, kijelzői és csatlakozói

Az alábbiakban bemutatásra kerül a vezérlő elő- és hátlapja. További részletek találhatóak a "Technical Information" című szakaszban.

### Az előlap leírása

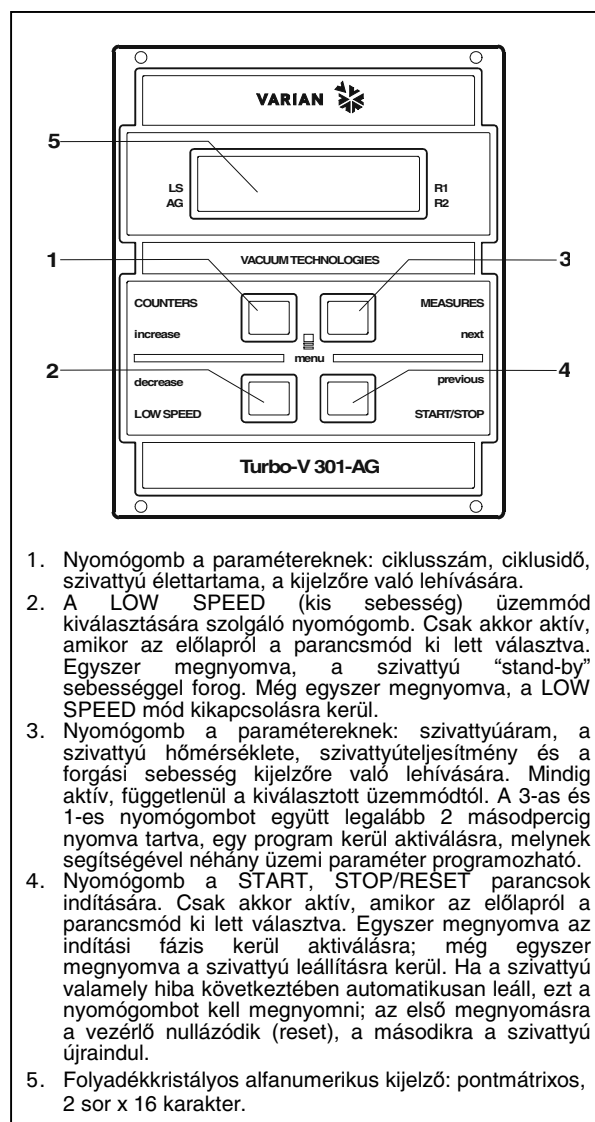

1. Nyomógomb a paramétereknek: ciklusszám, ciklusidő, szivattyú élettartama, a kijelzőre való lehívására.
2. A LOW SPEED (kis sebesség) üzemmód kiválasztására szolgáló nyomógomb. Csak akkor aktív, amikor az előlapról a parancsmód ki lett választva. Egyszer megnyomva, a szivattyú "stand-by" sebességgel forog. Még egyszer megnyomva, a LOW SPEED mód kikapcsolásra kerül.
3. Nyomógomb a paramétereknek: szivattyúáram, a szivattyú hőmérséklete, szivattyúteljesítmény és a forgási sebesség kijelzőre való lehívására. Mindig aktív, függetlenül a kiválasztott üzemmódtól. A 3-as és 1-es nyomógombot együtt legalább 2 másodpercig nyomva tartva, egy program kerül aktiválásra, melynek segítségével néhány üzemi paraméter programozható.
4. Nyomógomb a START, STOP/RESET parancsok indítására. Csak akkor aktív, amikor az előlapról a parancsmód ki lett választva. Egyszer megnyomva az indítási fázis kerül aktiválásra; még egyszer megnyomva a szivattyú leállításra kerül. Ha a szivattyú valamely hiba következtében automatikusan leáll, ezt a nyomógombot kell megnyomni; az első megnyomásra a vezérlő nullázódik (reset), a másodikra a szivattyú újraindul.
5. Folyadékkristályos alfanumerikus kijelző: pontmátrixos, 2 sor x 16 karakter.

A Turbo-V 301-AG számú vezérlő előlapja

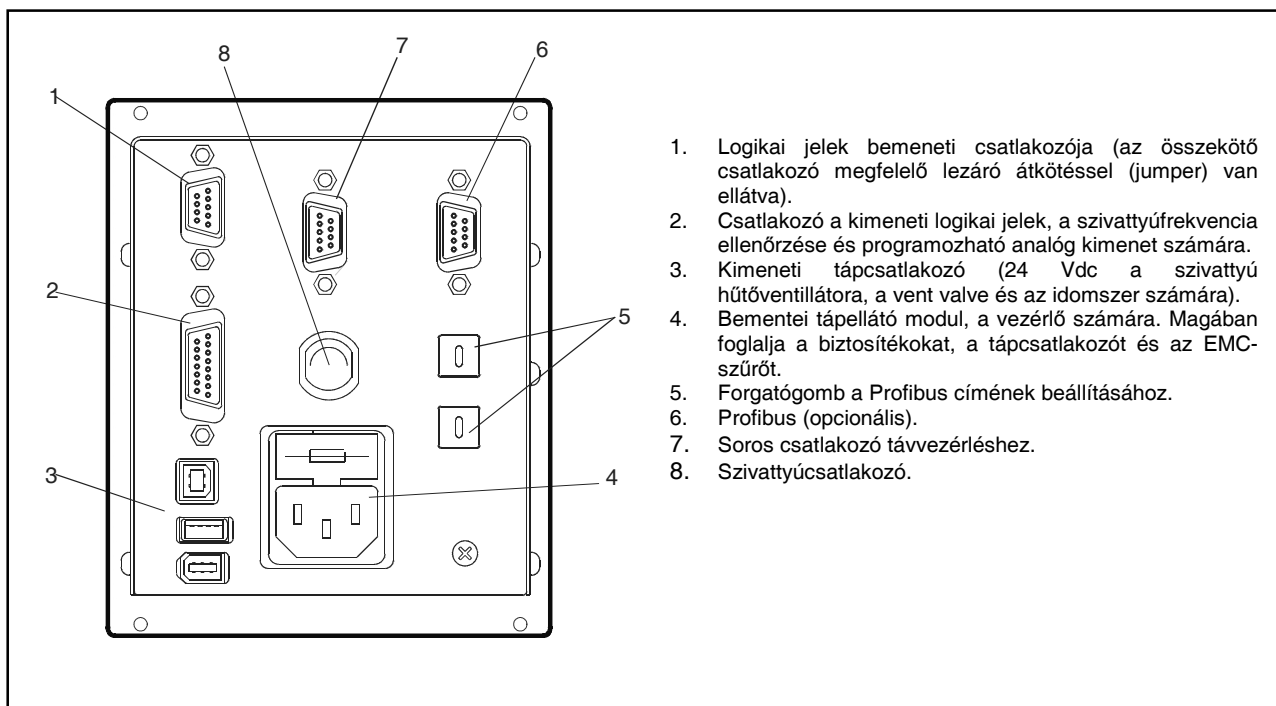

A Turbo-V 301-AG számú vezérlők hátlapja

## HASZNÁLATI ELJÁRÁSOK

### A vezérlő bekapcsolása

A vezérlő bekapcsolásához elegendő a hálózati kábelt a hálózati aljzatba illeszteni.

### A szivattyú beindítása

A szivattyú beindításához engedélyezni kell az interlock bemenetet és megnyomni az előlapon a START nyomógombot.

### A szivattyú leállítása

A szivattyú leállításához meg kell nyomni az előlapon található STOP nyomógombot.

## KARBANTARTÁS

A Turbo-V 301 Rack sorozatú vezérlők semmiféle karbantartást sem igényelnek. Valamennyi beavatkozást meghatalmazott személyzet hajthat csak végre.

Meghibásodás esetén igénybe vehető a Varian javítási szolgáltatása, vagy a "Varian advanced exchange service", mely a meghibásodott helyett, egy javított vezérlőt biztosít.



**VESZÉLY!**

A vezérlőn való bármely beavatkozás végrehajtása előtt ki kell húzni a hálózati csatlakozót.

Amikor egy vezérlőt le kell selejtezni, megsemmisítéskor a tárgykörbe tartozó nemzeti normáknak megfelelően kell eljárni.

## MEGSEMMISÍTÉS

**A címkén jelenlévő "WEEE" logo jelentése.** Az alább látható szimbólum az EK "WEEE" elnevezésű irányelvvel összhangban kerül alkalmazásra. Ez a szimbólum **(mely csak az Európai Közösség országaiban érvényes)**, azt jelzi, hogy a termék, melyen megtalálható, NEM kerülhet közönséges háztartási vagy ipari hulladékkal együtt megsemmisítésre, hanem azt egy szelektív hulladékgyűjtő rendszerbe kell továbbítani. A végfelhasználónak, a gyűjtési és megsemmisítési eljárás beindítása céljából, az adásvételi szerződés határidőinek és feltételeinek alapos áttanulmányozása után, fel kell vennie a kapcsolatot a berendezés szállítójával, legyen ez a gyártó vagy egy viszonteladó.

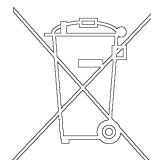

**HIBAÜZENETEK**

Néhány meghibásodási esetben a vezérlő öndiagnosztikai áramkörei hibaüzenetet jelenítenek meg (lásd az alábbi táblázatot).

<b>ÜZENET</b>	<b>LEÍRÁS</b>	<b>JAVÍTÁSI TEVÉKENYSÉG</b>
<b>CHECK CONNECTION TO PUMP</b>	Összeköttetési hiba a szivattyú és a vezérlő között, vagy a szivattyú hőmérséklete 0 °C alatt van.	Ellenőrizni, hogy a szivattyú és a vezérlő közti összekötő kábel mindkét végén jól van-e rögzítve és nincs e megszakadva. A szivattyú újraindításához kétszer megnyomni a START nyomógombot.
<b>WAITING INTERLOCK</b>	A P1 csatlakozó reteszelés jelen jele aktív a J1 csatlakozó 3. és 8. pin-je közti rövidzár megszakadása, vagy a külső reteszelő jel nyitott állapota következtében.	Visszaállítani a J1 csatlakozó 3. és 8. pin-je közti rövidzárát, vagy zární a külső reteszelő jelet.
<b>PUMP OVERTEMP.</b>	A felső csapágó vagy a szivattyú hőmérséklete meghaladta a 60 °C-t.	Várakozni, míg a hőmérséklet a küszöbérték alá esik. A szivattyú újraindításához kétszer megnyomni a START nyomógombot.
<b>CONTROLLER OVERTEMP.</b>	A vezérlő ának hőmérséklete túllépte a 70 °C-t, vagy a vezérlő hűtésének hőmérséklete túllépte a 60 °C-t.	Várakozni, míg a hőmérséklet a küszöbérték alá esik. A szivattyú újraindításához kétszer megnyomni a START nyomógombot.
<b>TOO HIGH LOAD</b>	A szivattyú által felvett áram meghaladja a programozott értéket.	Ellenőrizni, hogy a szivattyú forgórésze szabadon foroghat-e. A szivattyú újraindításához kétszer megnyomni a START nyomógombot.
<b>SHORT CIRCUIT</b>	Normál üzem közben (az indítási fázist követően) a kimeneti összeköttetés zárlatos.	Ellenőrizni az összeköttetéseket a szivattyú és a vezérlő között. A szivattyú újraindításához kétszer megnyomni a START nyomógombot.
<b>SYSTEM OVERRIDE</b>	A szivattyú leállt egy távérintkezőtől származó vészjel hatására.	Kihúzni a vezérlő hálózati csatlakozóját és megszüntetni a vészjelzés okát. Újra csatlakoztatni a hálózati kábelt, és kétszer megnyomni a START nyomógombot a szivattyú újraindításához.
<b>OVERVOLTAGE</b>	Meghibásodás történt a vezérlő tápellátási részegységében, vagy a vezérlő egy hamis jelet kapott.	A szivattyú újraindításához kétszer megnyomni a START nyomógombot. Ha az üzenet ismétlődik, a Varian-tól karbantartási beavatkozást kérni.
<b>POWER FAIL</b>	Meghibásodás a szivattyú vagy a vezérlő tápellátási részegységében.	A Varian-tól karbantartási beavatkozást kérni.

**INFORMACJE OGOLNE**

Urządzenie to jest przeznaczone do użytku zawodowego. Przed przystąpieniem do korzystania użytkownik powinien wnikliwie przesledzić zarówno ten podręcznik zawierający instrukcje jak również każda inna dostarczona przez Varian informacja. Varian uchyła się od jakiegokolwiek odpowiedzialności w przypadku całkowitego lub częściowego nie przestrzegania swoich instrukcji, przeznaczenia urządzenia niezgodnie z jego przeznaczeniem i jego obsługi przez personel uprzednio nie przeszkolony, naprawy urządzenia bez odpowiedniej autoryzacji lub przeznaczenia niezgodnego z obowiązującymi, specyficznymi normami krajowymi. Kontrolery z serii Turbo-V301 Rack są przetwornikami częstotliwości kontrolowanymi przez mikroprocesor zrealizowanymi z komponentów w stanie stałym i posiadającymi zdolności samodiagnostyczne i samoochronne.

Dane kontrolera:

- Operatywny frontalnie / w izolacji / seryjnie
- Sterowanie turbiny chłodzenia pompy z szybkością 24 Vdc
- Sterowanie vent valve
- Odczyt szybkości pracy pompy w momencie nakazu zatrzymania (odczyt szybkości w momencie zatrzymania)
- Odczyt ciśnienia
- Posrednik Profibus ( dodatkowy)
- Automatyczne ustawienie napięcia wejściowego.

W następnych paragrafach zawarte są wszystkie niezbędne informacje dotyczące gwarancji bezpieczeństwa personelu obsługującego urządzenie. Bardziej szczegółowe informacje są zawarte w dodatku do "Technical Information".

**Podręcznik ten opiera się na następujących konwencjach:**



**ZAGROZENIE!**

Sygnaly ostrzegające o zagrożeniu powinny zwrócić uwagę operatora na odpowiednią specyficzną procedurę która jeżeli nie jest przestrzegana w sposób prawidłowy może przyczynić się do poważnych obrażeń osoby obsługującej.



**UWAGA**

Sygnaly wzrokowe ukazujące się przed procedurą jeżeli zostaną zlekceważone mogą spowodować uszkodzenia urządzenia.

**PRZYPIS**

Przypisy zawierają najważniejsze informacje wyciągnięte z tekstu.

**MAGAZYNOWANIE**

Kontrolery podczas transportu i przechowywania w magazynie powinny mieć następujące warunki otoczenia:

- temperatura: od -20 °C do +70 °C
- wilgotność względna: od 0-95%(nie kondensująca)

**PRZYGOTOWANIE DO INSTALACJI**

Kontroler zostaje dostarczony w specjalnym, ochronnym opakowaniu; jeżeli opakowanie prezentuje jakiegokolwiek uszkodzenia które mogłyby powstać podczas transportu wówczas należy niezwłocznie powiadomić najbliższy, lokalny punkt sprzedaży.

Po

czasie operacji rozpakowywania należy zachować specjalną ostrożność żeby nie spowodować upadku kontrolera lub nie narazić na uderzenia.

Nie wyrzucać opakowania ponieważ jest ono całkowicie rycyklowalne i odpowiada normom CEE 85/399 dotyczącym ochrony środowiska.

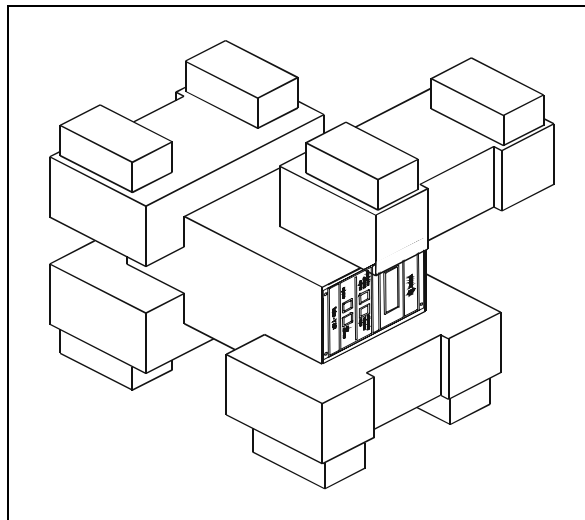

*Opakowanie kontrolera*

**INSTALACJA**



**ZAGROZENIE!**

Kontroler jest zasilany przy użyciu kabla składającego się z trzech przewodów (patrz tabela części na zamówienie) i rodzaju wtyczki odpowiadającej standardom międzynarodowym gwarantującego bezpieczne użytkowanie. Należy wyłącznie używać tego rodzaju kabla zasilającego i włączac wtyczkę do gniazdka odpowiadającego przepisom Unii Europejskiej tzn. posiadającego połączenie z masą celem wykluczenia iskrzeń.

We wnętrzu kontrolera powstają wysokie napięcia które mogą być przyczyną poważnych obrażeń lub wypadków śmiertelnych. Przed przystąpieniem do jakiegokolwiek operacji instalowania lub konserwacji należy odłączyć go od źródła zasilania.

**PRZYPIS**

Kontroler może być zainstalowany na stole lub wewnątrz odpowiedniego Rack. W obydwu przypadkach należy pamiętać aby wokół kontrolera zapewnić swobodny przepływ powietrza dla prawidłowego chłodzenia. Nie instalować i/lub użytkować kontrolerów w miejscach narażonych na działanie warunków atmosferycznych (jak deszcz, mroz, śnieg), pyłom, gazom agresywnych w środowisku wybuchowym lub o dużym stopniu zagrożenia pożarowego.

Podczas pracy kontrolera należy zapewnić następujące warunki otoczenia:

- temperatura: od 5 °C do +45 °C
- wilgotność względna: 0 - 95% (nie kondensująca).

Sposób połączenia i instalowania akcesoriów jest opisany w rozdziale "Technical Information".

**UZYTKOWANIE**

Paragraf ten zawiera podstawowe procedury operatywne. Dla uzyskania dodatkowych bardziej szczegółowych informacji lub dostępu do procedur na temat połączeń lub akcesoriów skonsultować paragraf "Use" znajdujący się w dodatku do "Technical Information".

Przed przystąpieniem do użytkowania kontrolera wykonać wszystkie połączenia elektryczne i pneumatyczne podłączenie pompy konsultować z odnośną instrukcją.



**ZAGROZENIE!**

Dla uniknięcia obrażeń personelu obsługującego urządzenie jak również uszkodzeń samego urządzenia należy upewnić się, szczególnie w przypadku gdy pompa została ustawiona na stole, czy stol jest odpowiednio stabilny. Pod żadnym pozorem nie uruchamiać pompy jeżeli kolnierz wejściowy nie jest połączony z systemem lub nie jest zamknięta kolnierzem zamykającym.

**PRZYPIS**

W przypadku kiedy nie zostanie wykonane żadne połączenie zewnętrzne łącznik zamykający J1 powinien pozostać połączony ze swoim mostkiem. Pompa wstępnej próżni i pompa Turbo-V mogą być uruchomione jednocześnie.

**STEROWNIKI, WSKAZNIKI I LACZNIKI**

Poniższe rysunki przedstawiają panel frontalny i tylny kontrolera. Dla uzyskania dokładniejszych szczegółów skonsultować odpowiedni rozdział "Technical Information".

**Opis pulpitu frontального**

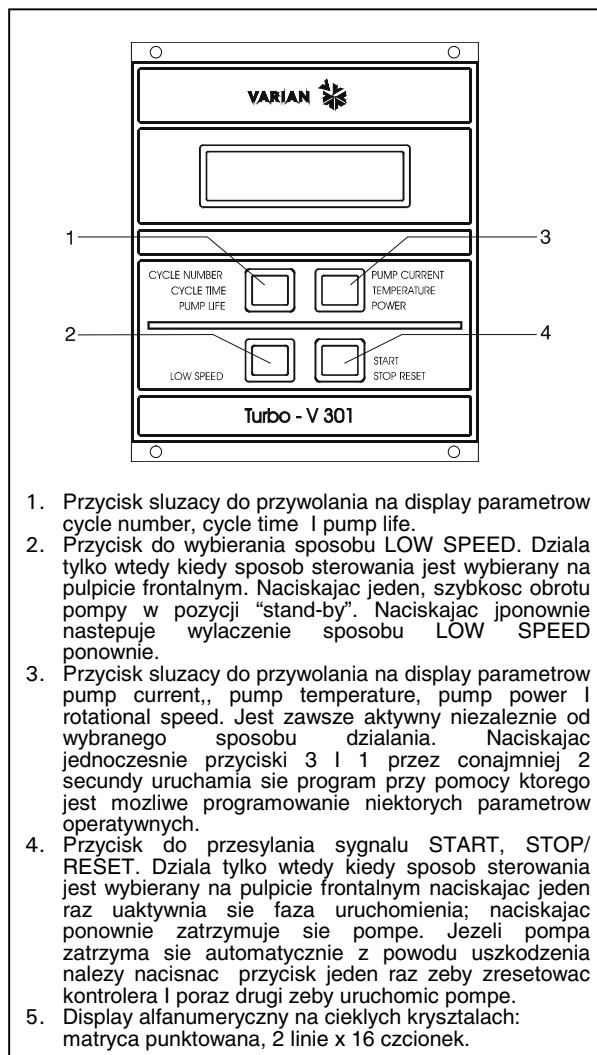

1. Przycisk służący do przywołania na display parametrów cycle number, cycle time i pump life.
2. Przycisk do wybierania sposobu LOW SPEED. Działa tylko wtedy kiedy sposób sterowania jest wybierany na pulpicie frontálním. Naciskając jeden, szybkość obrotu pompy w pozycji "stand-by". Naciskając ponownie następuje wyłączenie sposobu LOW SPEED ponownie.
3. Przycisk służący do przywołania na display parametrów pump current, pump temperature, pump power i rotational speed. Jest zawsze aktywny niezależnie od wybranego sposobu działania. Naciskając jednocześnie przyciski 3 i 1 przez co najmniej 2 sekundy uruchamia się program przy pomocy którego jest możliwe programowanie niektórych parametrów operacyjnych.
4. Przycisk do przesyłania sygnału START, STOP/RESET. Działa tylko wtedy kiedy sposób sterowania jest wybierany na pulpicie frontálním naciskając jeden raz uaktywnia się faza uruchomienia; naciskając ponownie zatrzymuje się pompe. Jeżeli pompa zatrzyma się automatycznie z powodu uszkodzenia należy nacisnąć przycisk jeden raz żeby zresetować kontrolera i poraz drugi żeby uruchomić pompe.
5. Display alfanumeryczny na ciekłych kryształach: matryca punktowana, 2 linie x 16 czcionek.

Pulpit frontálny kontrolera Turbo-V 301-AG



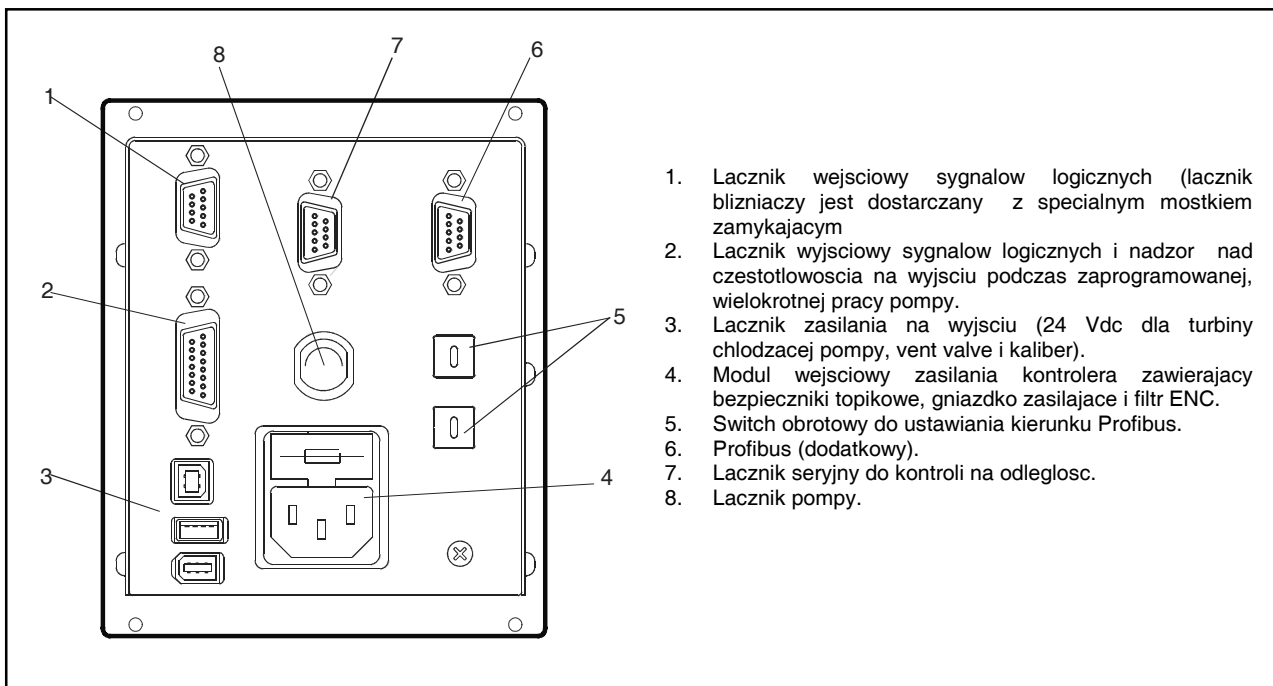

1. Laczniak wejsciowy sygnalow logicznych (laczniak blizniaczy jest dostarczany z specjalnym mostkiem zamykajacym)
2. Laczniak wyjsciowy sygnalow logicznych i nadzor nad czestotlowoscia na wyjsciu podczas zaprogramowanej, wielokrotnej pracy pompy.
3. Laczniak zasilania na wyjsciu (24 Vdc dla turbiny chlodzacej pompy, vent valve i kaliber).
4. Modul wejsciowy zasilania kontrolera zawierajacy bezpieczniki topikowe, gniazdko zasilajace i filtr ENC.
5. Switch obrotowy do ustawiania kierunku Profibus.
6. Profibus (dodatkowy).
7. Laczniak seryjny do kontroli na odleglosc.
8. Laczniak pompy.

*Pulpit tylny kontrolerow Turbo-V 301-AG*

**PROCEDURE UZYTEKOWANIA**

**Zaswiecenie kontrolera**

*Do zaswiecenia kontrolera wystarczy wprowadzic kabel zasilajacy do gniazdka sieci.*

**Uruchomienie pompy**

Zeby uruchomic pompe nalezy odblokowac wejscie interlock i nacisnac znajdujacy sie na pulpicie frontalnym przycisk START .

**Zatrzymanie pompy**

Do zatrzymania pompy wystarczy nacisnac przycisk STOP znajdujacy sie na pulpicie frontalnym.

**KONSERWACJA**

Kontroler z serii Turbo-V 301 Rack nie wymaga zadnej konserwacji. Jakakolwiek interwencja moze byc dokonywana wylacznie przez osoby autoryzowane

W przypadku uszkodzenia mozliwe jest korzystanie z serwisow naprawczych Varian lub "Varian advance exchange service"., w ktorym mozna otrzymac kontroler zregenerowany zastepujac go tym uszkodzonym.

**PRZETWORSTWO ODPADOW**

**Objasnienie znajdujacego sie na etykiecie znaczenia logo "WEEE".**

Uzyty ponizej symbol jest zgodny z wymogiem zarzadzenia "WEEE" Unii Europejskiej.

Symbol ten (**prawomocny tylko w krajach Unii Europejskiej**) oznacza, ze wyrob ktory nim zostal oznaczony NIE moze byc przetworzony jako odpad razem z innymi domowymi lub przemyslowymi natomiast musi byc skladowany w miejscu przeznaczonym dla odpadow do przerobki zroznicowanej .

Dlatego tez poleca sie uzytkownikowi, , po uprzedniej weryfikacji terminu i warunkow zawartych w kontrakcie sprzedazy, nawiazac kontakt z dostawca lub sprzedawca urzadzenia w celu uruchomienia procesu zbiorki i przerobu.

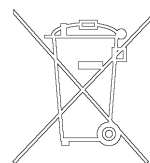

**ZAGROZENIE!**

Przed wykonaniem jakiegokolwiek interwencji na kontrolerze nalezy odlaczyc kabel zasilajacy.

W przypadku decyzji zlomowania nalezy przeprowadzic operacje respektujac krajowe specyficzne normy.

**BLEDNE INFORMACJE**

W niektórych przypadkach uszkodzeń obwodu do autodiagnozy kontrolera pokazuje niektóre błędne informacje wymienione w poniższej tabeli.

<b>INFORMACJA</b>	<b>OPIS</b>	<b>AKCJA KORYGUJĄCA</b>
<b>CHECK CONNECTION TO PUMP</b>	Zakłócenia na połączeniu między pompą i kontrolerem. Lub Temperatura pompy jest poniżej 0 °C.	Zweryfikować czy kabel łączący pompę z kontrolerem jest dobrze zamocowany na obydwu końcach i czy nie jest przerywany. Nacisnąć dwa razy przycisk START dla ponownego uruchomienia pompy.
<b>WAITING INTERLOCK</b>	Jest aktywny sygnał Interlock na łączniku P1 spowodowany zwarcie między pin 3 i pin 8 łącznika J1, Lub na skutek otwarcia sygnału zewnętrznego interlock.	Dokonanie naprawy obwodu elektrycznego pomiędzy pin 3 i pin 8 łącznika J 1 lub zamknąć sygnał interlock zewnętrzny.
<b>PUMP OVERTEMP.</b>	Temperatura górnego łożyska lub pompy przekroczyła 60 °C.	Odczekać aż temperatura się obniży poniżej ustalonego poziomu. Nacisnąć dwa razy przycisk START dla ponownego uruchomienia pompy.
<b>CONTROLLER OVERTEMP.</b>	Temperatura w kontrolerze przekroczyła 70 °C. Lub Temperatura grzejnika nie przekracza 60 °C.	Odczekać aż temperatura się obniży poniżej ustalonego poziomu. Nacisnąć dwa razy przycisk START dla ponownego uruchomienia pompy.
<b>TOO HIGH LOAD</b>	Absorpcja prądu przez pompę jest wyższa od zaprogramowanej.	Sprawdzić czy wirnik nie ma przeszkód w swobodnym obrocie. Nacisnąć dwa razy przycisk START dla ponownego uruchomienia pompy.
<b>SHORT CIRCUIT</b>	Podczas normalnej pracy (po fazie uruchomienia) na wyjściu są zwarcia.	Sprawdzić połączenie pompy z kontrolerem Nacisnąć dwa razy przycisk START dla ponownego uruchomienia pompy.
<b>SYSTEM OVERRIDE</b>	Pompa się zatrzymała na skutek sygnału zagrożenia pochodzącego od pierwotnego kontaktu.	Odczekać kabel zasilania kontrolera i sprawdzić przyczynę powstania sygnału zagrożenia. Podłączyć ponownie kabel zasilający i nacisnąć dwa razy przycisk START dla ponownego uruchomienia pompy.
<b>OVERVOLTAGE</b>	Nastąpiło uszkodzenie w sekcji zasilania kontrolera lub kontroler otrzymał sygnał nieprawidłowy.	Nacisnąć dwa razy przycisk START dla ponownego uruchomienia pompy. Jeżeli sygnał się powtórzy zwrócić się do Varian o przeprowadzenie konserwacji.
<b>POWER FAIL</b>	Uszkodzenie w sekcji zasilania pompy kontrolera.	Zwrócić się do Varian w celu naprawy.

## VŠEOBECNÉ INFORMACE

Tento přístroj je určen pro profesionální potřebu. Uživatel si musí před použitím tuto příručku velmi pozorně přečíst, ale i každou další aktualizaci, kterou podnik bude předávat. V důsledku nedostatečného i částečně nesprávného použití, nebo v případě chyb nevyškoleného personálu či neoprávněných zásahů a neodpovídajících specifickým státním normám, Varian nepřijímá a nenese žádnou zodpovědnost. Kontroléry série Turbo-V 301 Rack jsou frekvenčními konvertory, jsou kontrolovány mikroprocesorem a skládají se z pevných komponentů s autodiagnostickou a samoochrannou schopností.

Charakteristiky kontroléru:

- Čelní operativnost / dálková / seriální.
- Pilotáž o 24 Vdc ochlazovací lopatky čerpadla. Pilotáž vent valve.
- Čtení rychlosti čerpadla po příkazu zastavení (čtení rychlosti zastavení).
- Čtení tlaku.
- Rozhraní Profibus (opční).
- Automatické nastavení vstupního napětí.

V následujících odstavcích jsou uvedeny veškeré nutné informace, týkající se operátora a bezpečnostních podmínek během provozu přístroje. Detailní informace se nacházejí v dodatku "Technical Information".

Tato příručka používá následující běžná označení:



**NEBEZPEČÍ!**

Odkazy, které upozorňují na nebezpečí a donutí operátora, aby se řídil dle procedury nebo specifické praktiky, která nebude-li řádně vykonána, může ohrozit vážným způsobem jeho zdraví.



**POZOR**

Tyto zprávy bývají vizualizovány před jakoukoliv procedurou, je třeba se jimi řídit, aby nedošlo k poškození přístroje.

## POZNÁMKA

Poznámky, vyjmuté z textu obsahují velmi důležité informace.

## USKLADNĚNÍ

Během dopravy a skladování kontrolérů, se musí dbát na následující podmínky prostředí:

- teplota: od -20 °C do +70 °C
- relativní vlhkost: 0 - 95% (nesmí kondenzovat)

## PŘÍPRAVA K INSTALACI

Kontrolér je dodáván v speciálním ochranném balení; objeví-li se následkem dopravy nějaké poškození, je třeba se okamžitě obrátit na místní prodejní servis. Během rozbalování se obzvlášť musí dávat pozor, aby kontrolér nespadol nebo aby neutrpěl nárazy. Balicí materiál se nesmí odkládat v přírodě. Tento materiál se může kompletně recyklovat, neboť se shoduje se směrnici EU, CEE 85/399, které se týkají životního prostředí.

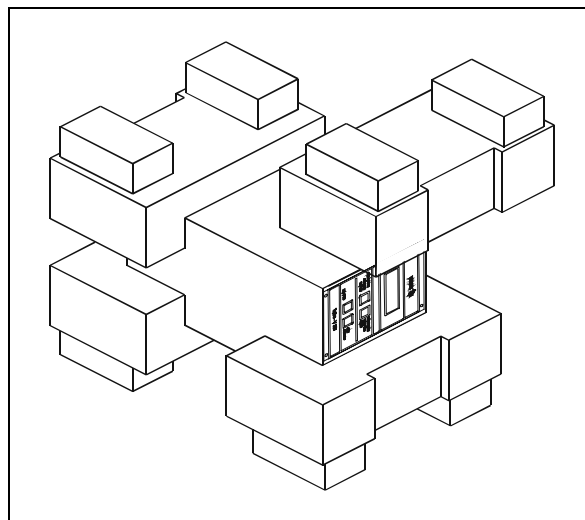

Obal kontroléru

## INSTALACE

**NEBEZPEČÍ!**

Kontrolér musí být napájen třídrátovým kabelem (viz tabulku součástí, které lze objednat) se zástrčkou shodnou s mezinárodním standardem, která zaručuje bezpečnost uživatele. Výše uvedený kabel je třeba neustále používat, zástrčku zasunovat do zásuvky s adekvátně uzeměným spojením, aby se předešlo elektrickým výbojům a aby se respektovaly směrnice CE.

Uvnitř kontroléru dochází k vysokým napětím, která jsou velmi nebezpečná i smrtící. Před provedením jakékoliv instalační či údržbové práce na kontroléru, je třeba ho odpojit od příkonu.

### POZNÁMKA

Kontrolér může být nainstalován na stole nebo uvnitř příslušného rack. V každém případě je třeba, aby okolo přístroje mohl vzduch volně proudit. Kontrolér se nesmí instalovat v místech vystavených atmosferickým vlivům (déšť, mráz, sníh), prachu, agresivním plynům, na výbušných místech nebo na místech kde existuje velké riziko požárů.

Během provozu je třeba, aby se respektovaly následující podmínky, týkající se operativního prostředí:

- teplota: od 5 °C do +45 °C;
- Relativní vlhkost: 0 - 95% (nesmí kondenzovat).

Pro další spojení a instalaci opčního příslušenství je třeba se podívat do sekce "Technical Information".

## POUŽITÍ

V tomto odstavci jsou uvedeny hlavní operativní postupy. Pro další detaily i pro procedury týkající se spojení nebo dalších opčních detailů, je třeba se obracet na odstavce "Use" v příloze "Technical Information". Veškerá elektrická a pneumatická spojení se musí vykonat před použitím kontroléru, při čemž je třeba se obracet na příslušnou příručku napojeného čerpadla.

**NEBEZPEČÍ**

Aby se vyhnulo nebezpečí, které může ohrozit osoby i přístroj, musí se zkontrolovat jeho stabilita v případě, že čerpadlo je položené na stole. Jestliže vstupní příruba není napojená na systém nebo není uzavřena se zavírací přírubou, čerpadlo se nesmí spustit do provozu.

### POZNÁMKA

Uzavírací konektor J1, jestliže nebude skutečně žádný vnější spojení, musí zůstat propojený se svým můstkem. Čerpadlo pre-prázdná a čerpadlo Turbo-V mohou být spuštěna současně.

### Ovládání, indikátory a konektory

V následujícím je ukázán čelní a zadní panel kontroléru. Pro širší detaily je třeba se obrátit na sekci "Technical Information".

### Popis čelního panelu

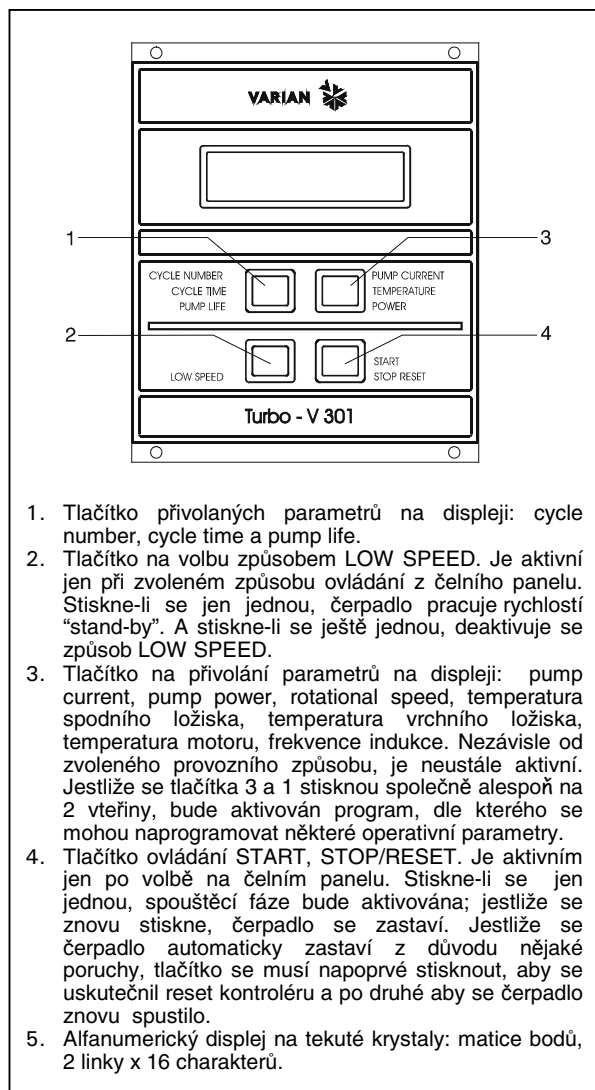

1. Tlačítko přivolání parametrů na displeji: cycle number, cycle time a pump life.
2. Tlačítko na volbu způsobem LOW SPEED. Je aktivní jen při zvoleném způsobu ovládání z čelního panelu. Stiskne-li se jen jednou, čerpadlo pracuje rychlostí "stand-by". A stiskne-li se ještě jednou, deaktivuje se způsob LOW SPEED.
3. Tlačítko na přivolání parametrů na displeji: pump current, pump power, rotational speed, temperatura spodního ložiska, temperatura vrchního ložiska, temperatura motoru, frekvence indukce. Nezávisle od zvoleného provozního způsobu, je neustále aktivní. Jestliže se tlačítka 3 a 1 stisknou společně alespoň na 2 vteřiny, bude aktivován program, dle kterého se mohou naprogramovat některé operativní parametry.
4. Tlačítko ovládání START, STOP/RESET. Je aktivní jen po volbě na čelním panelu. Stiskne-li se jen jednou, spouštěcí fáze bude aktivována; jestliže se znovu stiskne, čerpadlo se zastaví. Jestliže se čerpadlo automaticky zastaví z důvodu nějaké poruchy, tlačítko se musí napoprvé stisknout, aby se uskutečnil reset kontroléru a po druhé aby se čerpadlo znovu spustilo.
5. Alfanumerický displej na tekuté krystaly: matice bodů, 2 linky x 16 charakterů.

Čelní panel Kontroléru Turbo-V 301-AG

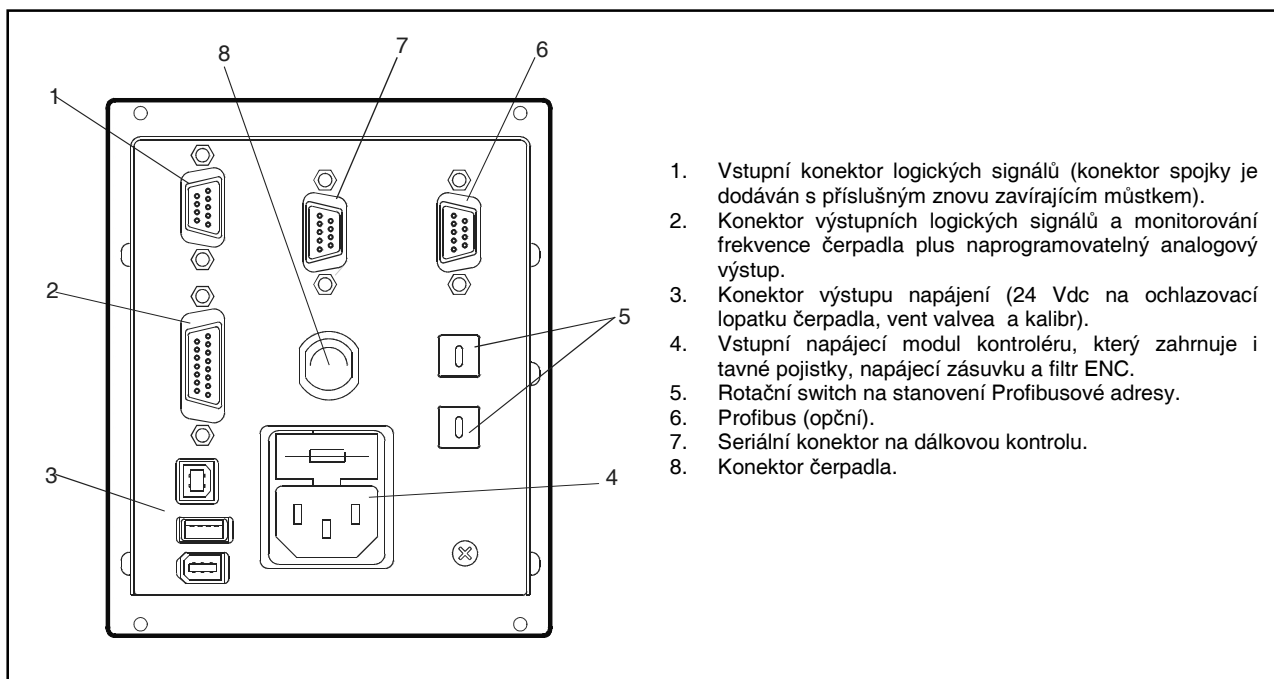

Zadní panel Kontroléru Turbo-V 301-AG

## POUŽÍVANÉ PROCEDURY

### Zapalování Kontroléru

Kontrolér se zapne vložením kabele do zásuvky na síti.

### Spouštění čerpadla

Ke spuštění čerpadla, je třeba oprávnit vstup interlocku a stisknout tlačítko START na čelním panelu.

### Zastavení čerpadla

Čerpadlo se zastaví stisknutím tlačítka STOP na čelním panelu.

## ÚDRŽBA

Kontrolér série Turbo-V 301 Rack nevyžadují žádnou údržbu. Jakýkoliv zásah musí být vykonáván jen oprávněným personálem.

V případě poruchy se může využít opravářského servisu Varian nebo "Varian advanced exchange service", kde poškozený kontrolér bude vyměněn za nový.



**NEBEZPEČÍ**

Nejdříve, před jakýmkoliv zásahem na kontroléru, se musí odpojit elektrický kabel.

Bude-li zapotřebí kontrolér likvidovat, musí se postupovat dle platných specifických státních norem.

## LIKVIDACE

**Význam loga "WEEE" nacházejícího se na štítku.** Níže uvedený symbol odpovídá směrnici CE pojmenovaným "WEEE". Tento symbol (**platný jen pro státy Evropské Unie**) určuje, že výrobek, který je takto označen NESMÍ být likvidován společně s ostatními domácími nebo průmyslovými odpady, ale je nutno ho předat do patřičných provozních sběrů, kde musí být tříděn a likvidován odděleně od městského odpadu.

Uživatel, který miní výrobek likvidovat doporučujeme, aby se nakontaktoval přímo s výrobcem nebo prodejcem, který se po patřičném prověření termínů a smluvních podmínek postará o kompletní likvidaci uvedeného výrobku.

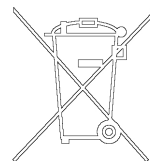

## CHYBNÉ ZPRÁVY

V některých případných poruchách na autodiagnostických obvodech, kontrolér předává několik chybných odkazů, které jsou vyjmenovány v tabulce, která se nachází na následující stránce.

ZPRÁVA	POPIS	KOREKCE
<b>CHECK CONNECTION TO PUMP</b>	Chybné fungování spojení mezi čerpadlem a kontrolérem (P31). Nebo Čerpadlo má nižší teplotu než je 0 °C.	Prověřit zda kabelové spojení mezi pumpou a kontrolérem je správně upevněné na obou dvou koncích a že nedošlo k přerušení. Stisknout tlačítko START dvakrát pro opětné spuštění čerpadla.
<b>WAITING INTERLOCK</b>	Aktivní signál interlock se nachází na konektoru P1, neboť došlo k přerušení zkratu mezi pin 3 a pin 8 del konektoru J1, nebo kvůli otevření signálu vnějšího interlock .	Znovu obnovit spojení nakrátko mezi pin 3 a pin 8 konektoru J1, nebo uzavřít signál vnějšího interlock.
<b>PUMP OVERTEMP.</b>	Teplota horního ložiska nebo čerpadla převýšila 60 °C.	Počkat až se teplota opět vrátí pod mezní hodnotu. Stisknout dvakrát tlačítko START pro opětné spuštění čerpadla.
<b>CONTROLLER OVERTEMP.</b>	Teplota kontroléru převýšila 70 °C. Nebo Teplota radiátoru kontroléru je vyšší než 60 °C.	Vyčkat až se teplota opět vrátí pod mezní hodnotu. Stisknout dvakrát tlačítko START pro opětné spuštění čerpadla.
<b>TOO HIGH LOAD</b>	Absorbovaný proud čerpadla je vyšší než ten naprogramovaný.	Prověřit, zda rotor čerpadla se může volně otáčet. Stisknout dvakrát tlačítko START pro opětné spuštění čerpadla.
<b>SHORT CIRCUIT</b>	Během normálního provozu (po spuštění fázi) výstupní spojení je ve zkratu.	Prověřit spojení mezi čerpadlem a kontrolérem. Stisknout dvakrát tlačítko START pro opětné spuštění čerpadla.
<b>SYSTEM OVERRIDE</b>	Pumpa byla zastavena nouzovým signálem prostřednictvím dálkového kontaktu.	Odpojit napájecí kabel kontroléru a napravit příčinu poplachu. Znovu připojit napájecí kabel a stisknout dvakrát tlačítko START pro opětné spuštění čerpadla.
<b>OVERVOLTAGE</b>	Vznikla porucha v napájecí sekci kontroléru, nebo kontrolér dostal falešný signál.	Stisknout dvakrát tlačítko START pro opětné spuštění čerpadla. Po opětné zprávě ohledně údržby je nutno se obrátit na Varian .
<b>POWER FAIL</b>	Porucha v napájecí sekci čerpadla, kontroléru.	Ohledně údržby je třeba se obrátit na Varian.

## VŠEOBECNÉ INFORMÁCIE

Tento prístroj slúži k profesionálnemu použitiu. Užívateľ si pred použitím tohto prístroja musí pozorne prečítať tento návod k použitiu a jeho ďalšie doplnky, dodané podnikom Varian. Podnik Varian nepreberá na seba žiadnu zodpovednosť za úplné, alebo čiastočné nedodržanie návodu, za nesprávne používanie prístroja nekompetentnými osobami, za nepovolené zásahy a za používanie, ktoré nie je v zhode s príslušnými národnými normami. "Controllers" série Turbo-V 301 Rack sú meniči kmitočtu, kontrolované mikroprocesorom, vyrobené prvkami pevnej fázy a so schopnosťou samodiagnostiky a samokontroly.

Charakteristiky controller-a:

- Čelné / dialkové / sériové riadenie
- 24 Vdc riadenie chladiacej lopatky čerpadla
- Riadenie vent valve
- Čítanie rýchlosti čerpadla po povelí zastavenia (čítanie rýchlosti zastavenia)
- Čítanie tlaku
- Medzičlánok Profibus (na objednávku)
- Automatické nastavenie vstupného napätia.

Ďalej sú popísané všetky potrebné informácie, ktorých úlohou je zabezpečiť bezpečnosť pracovníka počas používania prístroja.

Podrobné informácie sú uvedené v dodatku "Technical Information".

Tento návod používa nasledujúce signály:



**NEBEZPEČIE!**

Signál nebezpečie upozorňuje pracovníka na určitý pracovný postup, ktorý, keď nie je prevedený správne, môže zapríčiniť vážne osobné poranenia.



**POZOR!**

Signály "pozor" sú pred tými postupmi, ktoré, v prípade ich nedodržania, môžu poškodiť prístroj.

**POZNÁMKA**

Poznámky zahrňujú dôležité informácie, vytiahnuté z textu.

## USKLADŇOVANIE

Počas prepravy a uskladňovania "Controllers" musia byť dodržané tieto podmienky prostredia:

- teplota: od -20 °C do +70 °C
- relatívna vlhkosť: 0 - 95% (bez kondenzátu)

## PRÍPRAVA PRE INŠTALÁCIU

"Controller" je dodaný v špeciálnom ochrannom obale; keby ste objavili škodu, spôsobenú prepravou, skontaktujte sa s kanceláriou miestneho predaja.

Pri rozbaľovaní dávajte pozor, aby vám "Controller" nespadol, alebo niekde nenarazil. Obal nezahadzujte. Je vyrobený z recyklovateľného materiálu a zodpovedá smernici CEE 85/399 pre ochranu životného prostredia

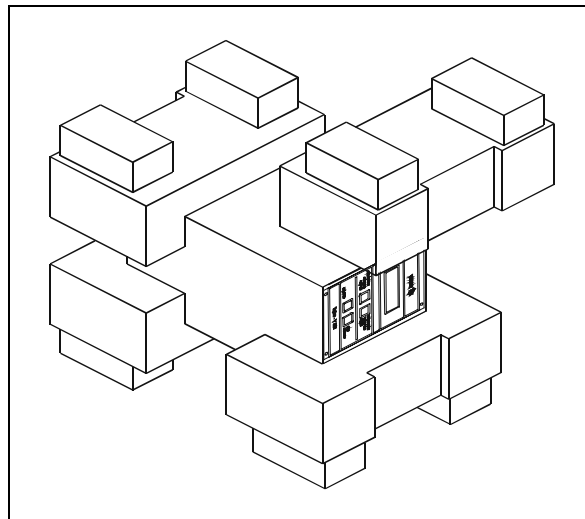

Obal controller

## INŠTALÁCIA



**NEBEZPEČIE!**

Controller musí byť napojený na sieť s trojdôtočným napájacím káblom (viď tabuľku objednávajúcich súčiastok) so zástrčkou, ktorá zodpovedá medzinárodnej úrovni a tak zabezpečuje bezpečnosť užívateľa. Používajte výhradne tento napájací kábel a zástrčku zasúvajte do zástrčky, ktorá má vhodné uzemnenie, aby ste sa vyhli elektrickému výboju. Táto musí rešpektovať stanovenia EÚ.

Vo vnútri "controller" sa vytvára vysoké napätie, ktoré môže spôsobiť vážne škody alebo smrť. Pred akýmkoľvek úkonom, týkajúceho sa inštalácie alebo údržby "controller-a" nezabudnite vytiahnuť zástrčku z elektrickej zásuvky.

### POZNÁMKA

"Controller" môže byť inštalovaný na pracovnom stole alebo vo vnútri track. V každom prípade je potrebné, aby chladiaci vzduch mohol voľne krúžiť okolo prístroja. "Controller" nepoužívajte a neinštalujte v prostredí, vystavenom atmosférickým vplyvom (dážď, mráz, sneh), prachu, agresívnym plynom a v prostredí s vysokým rizikom požiaru.

Počas chodu je dôležité, aby boli rešpektované tieto podmienky prostredia:

- teplota: od 5 °C do +45 °C
- relatívna vlhkosť: 0 - 95% (nekondenzovaná).

Pre ostatné napojenia a inštaláciu zvoliteľného príslušenstva viď časť "Technical Information".

## POUŽITIE

V tomto odstavci sú uvedené hlavné operatívne postupy. Pre ostatné detaily a pre postupy, ktoré sa vzťahujú na napojenia, alebo na zvolené príslušenstvo, postupujte podľa časti "Use" v dodatku "Technical Information".

Pred použitím "Controller" prevedte všetky potrebné elektrické a pneumatické napojenia a riadte sa podľa návodu napojeného čerpadla.



**NEBEZPEČIE!**

Aby ste sa vyhli sobnému nebezpečeniu a poškodeniu prístroja, skontrolujte, aby čerpadlo, umiestnené na pracovnom stole bolo stabilné. Čerpadlo nikdy nenašartujte vtedy, keď vstupná príruha nie je napojená na systém, alebo nie je zavretá s uzáverovou prírubou.

### POZNÁMKA

Uzavierajúca prípojka J1 sa musí nechať napojená na jej mostík vtedy, keď nie je prevedené žiadne vonkajšie napojenie. Pred-prázdňové čerpadlo a čerpadlo Turbo-V môžu byť zapnuté súčasne.

### Povely, Ukazovatele a Prípojky

Ďalej je zobrazený čelný a zadný panel controller-a. Pre ďalšie detaily konzultuje časť "Technical Information".

### Popis čelného panelu

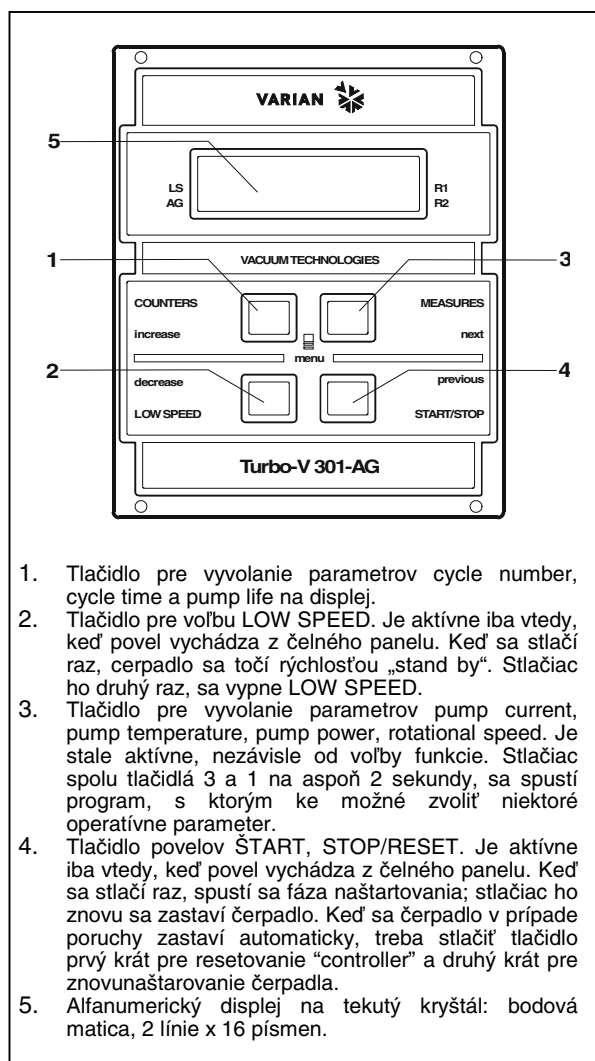

1. Tlačidlo pre vyvolanie parametrov cycle number, cycle time a pump life na displej.
2. Tlačidlo pre voľbu LOW SPEED. Je aktívne iba vtedy, keď povel vychádza z čelného panelu. Keď sa stlačí raz, čerpadlo sa točí rýchlosťou „stand by“. Stlačiac ho druhý raz, sa vypne LOW SPEED.
3. Tlačidlo pre vyvolanie parametrov pump current, pump temperature, pump power, rotational speed. Je stále aktívne, nezávisle od voľby funkcie. Stlačiac spolu tlačidlá 3 a 1 na aspoň 2 sekundy, sa spustí program, s ktorým ke možné zvolit' niektoré operatívne paraméter.
4. Tlačidlo povelov ŠTART, STOP/RESET. Je aktívne iba vtedy, keď povel vychádza z čelného panelu. Keď sa stlačí raz, spustí sa fáza naštartovania; stlačiac ho znovu sa zastaví čerpadlo. Keď sa čerpadlo v prípade poruchy zastaví automaticky, treba stlačiť tlačidlo prvý krát pre resetovanie "controller" a druhý krát pre znovunaštartovanie čerpadla.
5. Alfonumerický displej na tekutý kryštál: bodová matica, 2 línie x 16 písmen.

Čelný panel controller Turbo-V 301-AG



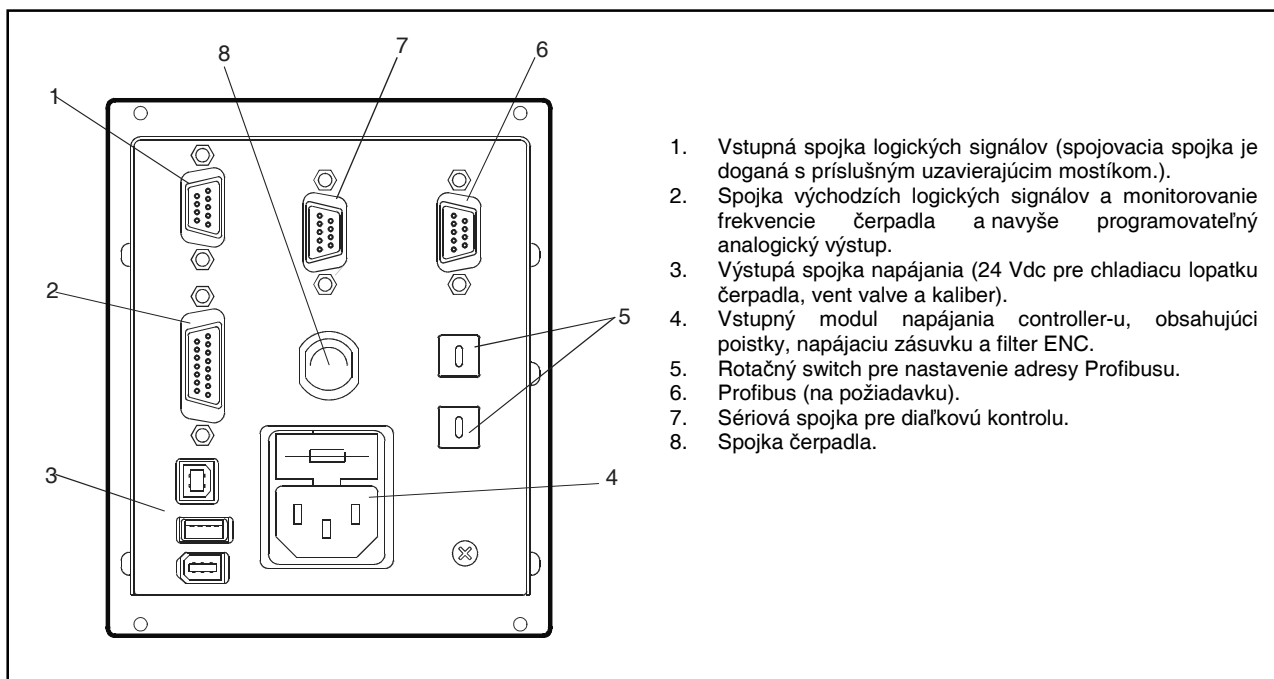

Zadný panel "controller Turbo-V 301-AG

## POSTUP PRE POUŽITÍ

### Zapnutie "controller"

Pre zapnutie "controller" stačí zapojiť kábel na elektrickú sieť a vypínač siete dať do polohy 1.

### Naštartovanie čerpadla

Pre naštartovanie čerpadla je potrebné sprístupniť vstup interlock a stlačiť tlačidlo START na čelnom paneli.

### Zastavenie čerpadla

Pre zastavenie čerpadla treba stlačiť tlačidlo STOP na čelnom paneli.

## ÚDRŽBA

"Controllers" série Turbo-V 301 Rack nevyžadujú žiadnu údržbu. Akýkoľvek zásah musí previesť poverený personál.

V prípade vady je možné využiť opravnú službu Varian alebo "Varian advanced exchange service", ktorá vymení vadný "controller".



**NEBEZPEČIE!**

Pred akýmkoľvek zásahom na "controller" vyťahnite šnúru z elektrickej siete.

V prípade, že "controller" musí ísť do zberu, riadte sa platnými príslušnými národnými normami.

## LIKVIDÁCIA

**Význam loga "WEEE" nachádzajúceho sa na štítkoch.**

Aplikovanie doloženačného symbolu dodržiava smernicu EÚ s názvom "WEEE".

Tento symbol (**platný iba pre štáty Európskej Únie**) znamená, že výrobok s týmto štítkom NEMIE byť odstránený spolu s bežným domácim alebo priemyselným odpadom, ale sa musí odstrániť ako delený odpad.

Vyzývame preto konečného užívateľa, aby sa skontaktoval s dodávateľom prístroja, či už je to výrobca alebo predajca za účelom jeho likvidácie podľa zmluvných podmienok predaja.

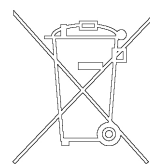

**OZNAMY VÁD**

V niektorých prípadoch, týkajúcich sa vúd, obvod samodiagnostiky "controller" signalizuje niekoľko oznamov vúd, uvedených na ďalšej strane.

OZNAM	POPIS	ZÁSAH OPRAVY
<b>CHECK CONNECTION TO PUMP</b>	Nefunguje napojenie medzi čerpadlom a "controller". Alebo Čerpadlo má nižšiu teplotu ako 0 °C.	Skontrolujte, či je spojovací kábel medzi čerpadlom a "controller" správne zasunutý na oboch koncoch a či nie je prerušený. Stlačte dvakrát tlačidlo START pre znovunaštartovanie čerpadla.
<b>WAITING INTERLOCK</b>	Je aktívny signál interlock na spojke P1 z dôvodu prerušenia skratu medzi pin 3 a pin 8 spojky J1, alebo z dôvodu otvorenia signálu vonkajšieho interlock.	Obnoviť skrat medzi pin 3 a pin 8 spojky J1, alebo zavrieť signál vonkajšieho interlock.
<b>PUMP OVERTEMP.</b>	Teplota horného ložiska alebo čerpadla prekročila 60 °C.	Vyčkať, až sa teplota opäť vráti pod hranicu. Stlačte dvakrát tlačidlo START pre znovunaštartovanie čerpadla.
<b>CONTROLLER OVERTEMP.</b>	Teplota "controller" prekročila 70 °C. Alebo Teplota radiátora controllera presahuje 60 °C.	Počkať, kým teplota neklesne pod hranicu. Stlačte dvakrát tlačidlo START pre znovunaštartovanie čerpadla
<b>TOO HIGH LOAD</b>	Počas bežného chodu (po naštartovaní) čerpadlom absorbovaný prúd prevyšuje ten naprogramovaný.	Skontrolujte, či má rotor čerpadla možnosť točiť sa voľne. Stlačte dvakrát tlačidlo START pre znovunaštartovanie čerpadla
<b>SHORT CIRCUIT</b>	Počas bežného chodu (po naštartovaní) východzie napojenie je v skrate.	Skontrolujte napojenia medzi čerpadlom a "controller". Stlačte dvakrát tlačidlo START pre znovunaštartovanie čerpadla
<b>SYSTEM OVERRIDE</b>	Núdzový signál, vychádzajúci z diaľkového kontaktu zastavil čerpadlo.	Vytiahnite šnúru z elektrickej siete "controller" a odstráňte dôvod alarmu. Zasuňte napájaciu šnúru a stlačte dvakrát tlačidlo START pre znovunaštartovanie čerpadla.
<b>OVERVOLTAGE</b>	Objavila sa vada v sekcii napájania "controller", alebo "controller" dostal falošný signál.	Stlačte dvakrát tlačidlo START pre znovunaštartovanie čerpadla. Keď sa tento oznam objaví znovu, obráťte sa na firmu Varian pre údržbu.
<b>POWER FAIL</b>	Vada v napájacom systéme čerpadla, controllera.	Pre údržbu sa obráťte na Varian.

## SPLOŠNE INFORMACIJE

Naprava je namenjena samo za strokovno rabo. Uporabnik mora temeljito prebrati priročnik in pri tem upoštevati vsako dodatno informacijo, ki jo nudi Varian. Varian ne odgovarja v slučaju celotnega ali delnega nespoštovanja navodil, pri nepravilni uporabi nestrokovnega osebja, v slučaju nedovoljenih posegov ali pri zanemarjenju specifičnih nacionalnih meril. Controllerji serije Turbo-V 301 Rack so frekvenčni pretvorniki, na katere nadzor ima mikrokrmilnik. Sestavljajo jih deli v solidnem stanju, ki imajo značilnosti avtodiagnoze in avtozaščite.

Značilnosti controllerja:

- Osprednja/oddaljena/serijska operativnost
- Upravljanje na 24 Vdc ventila ohlajevalne črpalke
- Upravljanje vent valve
- Branje hitrosti črpalke po ukazu zaustavitve (branje zaustavitvene hitrosti)
- Branje pritiska
- Vmesnik Profibus (opsijski)
- Avtomatična postavitev vhodne napetosti.

V naslednjih odstavkih so navedene vse informacije potrebne za zagotavljanje sigurnosti uporabnika med rokovanjem s to napravo. Podrobnejše informacije dobite v priponki "Technical Information".

**V tem priročniku so varnostne informacije razvrščene v dva razreda:**



### **SVARILO!**

Znak svarila opozarja uporabnika, da mora pri določenem postopku ali pri posebnem delovanju paziti. Kršitev svarila lahko privede do lažjih ali hudih telesnih poškodb.



### **POZOR**

Znak 'pozor' se pojavi pred postopke, ki če jih uporabnik zanemari, lahko napravo poškoduje.

### **OPOMBA**

Opombe vsebujejo vse najbolj pomembne informacije iz besedila.

## SKLADIŠČENJE

Med transportom in skladiščenjem controllerjev morate zagotoviti naslednje pogoje okolice:

- temperatura: od -20 °C do +70 °C
- relativna vlaga: 0 - 95% (ne-kondenzna)

## PRIPRAVA ZA MONTAŽO

Controller dobite v posebni zaščitni embalaži; če so na embalaži znaki poškodbe, ki naj bi nastale med transportom obrnite se krejavnemu prodajalnemu biroju.

Pri odstranitvi embalaže, morate še posebno paziti, da controller ne pade na tla ali da ne podleigne udarcem.

Ne zavržite embalažo v okolico. Material lahko v celotri reciklirate in ustreza direktivi CEE 85/399 za zaščito okolja.

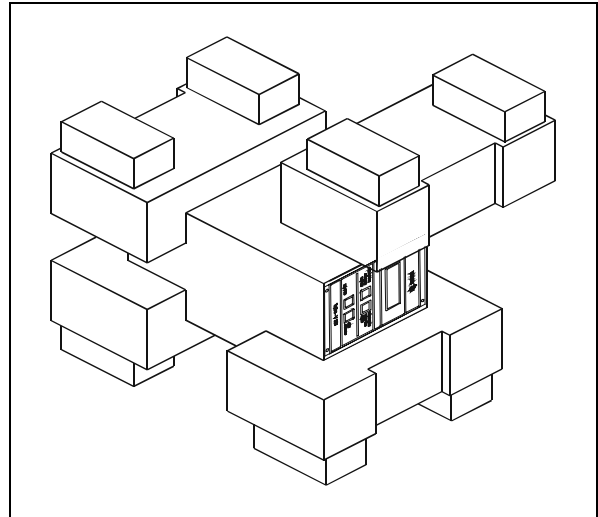

Embalaža controllera

**MONTAŽA**



**SVARILO!**

Controller ima napajalni vod s tremi žicami (gledaj tudi preglednico delov, ki lahko naročiš) in mednarodno priznan vtičač za varnost uporabnika. Uporabljajte vedno ta napajalni kabel in vtaknite vtičač v vtičnico z ustreznim masovnim vezanjem, ker drugače vas lahko strese električni tok in da se tako pridržite ES meril. Znotraj controller-jev se stvori visoka napetost, ki lahko človeku povzroči hude poškodbe ali celo smrt. Preden bi nadaljevali s katerokoli dejavnostjo montaže ali pa vzdrževanja, izklopite controller iz vtičnice.

**OPOMBA**

Controller lahko montirate na mizo ali vgradite v notranjost ustreznega rack-a. V vsakem slučaju morate poskrbeti, da voda za hlajenje prosto kroži skozi napravo. Controller-a ne smete montirati ali uporabiti v okolici, ki je izpostavljena klimatskim dejavnikom (dežju, ledu, snegu), prahu, agresivnim plinom, v okolici kjer obsatja nevarnost vnetja ali požara.

Med delovanjem morajo biti zagotovljeni naslednji pogoji okolice:

- temperatura: od 5 °C do +45 °C
- relativna vlaga: 0 - 95% (ne-kondezna).

Kar se tiče priključkov in montaže opcionalnih dodatkov, si lahko ogledate priponko "Technical Information".

**UPORABA**

V tem odsatvku so navedeni vsi glavni operativni postopki. Za dodatne detalje in postopke, ki zadevajo priključitve ali posamezne opcije, si lahko ogledate odstavek "Use" v priponki "Technical Information". Predno bi uporabili controller, morate priključiti vse električne in pnevmatske kable, pri tem se nanajšate na priročnik priložene črpalke.



**SVARILO!**

Da bi se izognili poškodbam bodisi oseb kot naprave, morate poskrbeti, da ste črpalko stabilno položili (če ste jo vgradili na mizo). Črpalka ne sme nikoli delovati, če vhodna prirobnica ni priklopljena k sistemu ali če ni zaprta s zapiralno prirobnico.

**OPOMBA**

Zapiralni konektor J1 mora ostati priključen k svojemu mostičku, če niste izvršili nikakršne druge zunanje priključitvije. Črpalko predhodnega praznjenja in črpalko Turbo-V lahko istočasno vklopite.

**Komande, indikatorji in konektorji**

Sledi prikaz prednje in ozadnje plošče controllera. Za podrobnejše informacije si ogledajte paragraf "Technical Information".

**Opis prednje plošče**

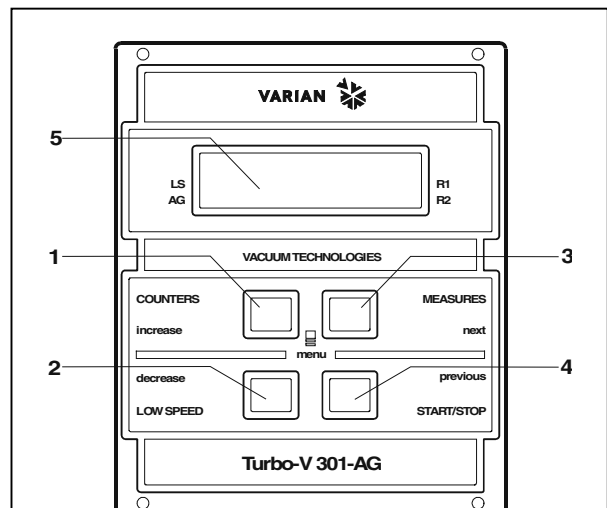

1. Tipka za preključitev na zaslonu parametrov cycle number, cycle time in pump life.
2. Tipka za LOW SPEED modus je aktivna samo nato, ko ste izbrali to komando iz prednje plošče. Če gumb enkrat pritisnete, črpalka vrtil na hitrosti "stand-by". Če še enkrat pritisnete gumb, izključite LOW SPEED modus.
3. Tipka za preključitev na zaslonu parametrov pump current, pump power, rotational speed, temperatura spodnjega ležišča temperatura gornjega ležišča, temperatura motorja, frekvenca vzburljenja. Ta tipka je vedno aktivna neodvisno od modusa delovanja, ki ste ga izbrali. Če skupaj pritisnete gumbe 3 in 1 za vsaj dve sekundi aktivirate program, s katerim je mogoče nastaviti nekatere operativne parametre.
4. Tipka za zagon komand START, STOP/RESET. Aktivna je samo nato, ko ste to komando izbrali iz prednje plošče. Če gumb enkrat pritisnete boste pognali črpalko; če ga še enkrat pritisnete, boste črpalko zaustavili. Če se je črpalka sama zaustavila zaradi kvara, morate to tipko enkrat pritisniti, da bi lahko controller-a resetirali in še drugič za ponoven zagon črpalke.
5. Alfaštevilčni zaslon iz tekočih kristalov: prebija 2 linije x 16 znaka.

Prednja plošča Controllera Turbo-V 301-AG

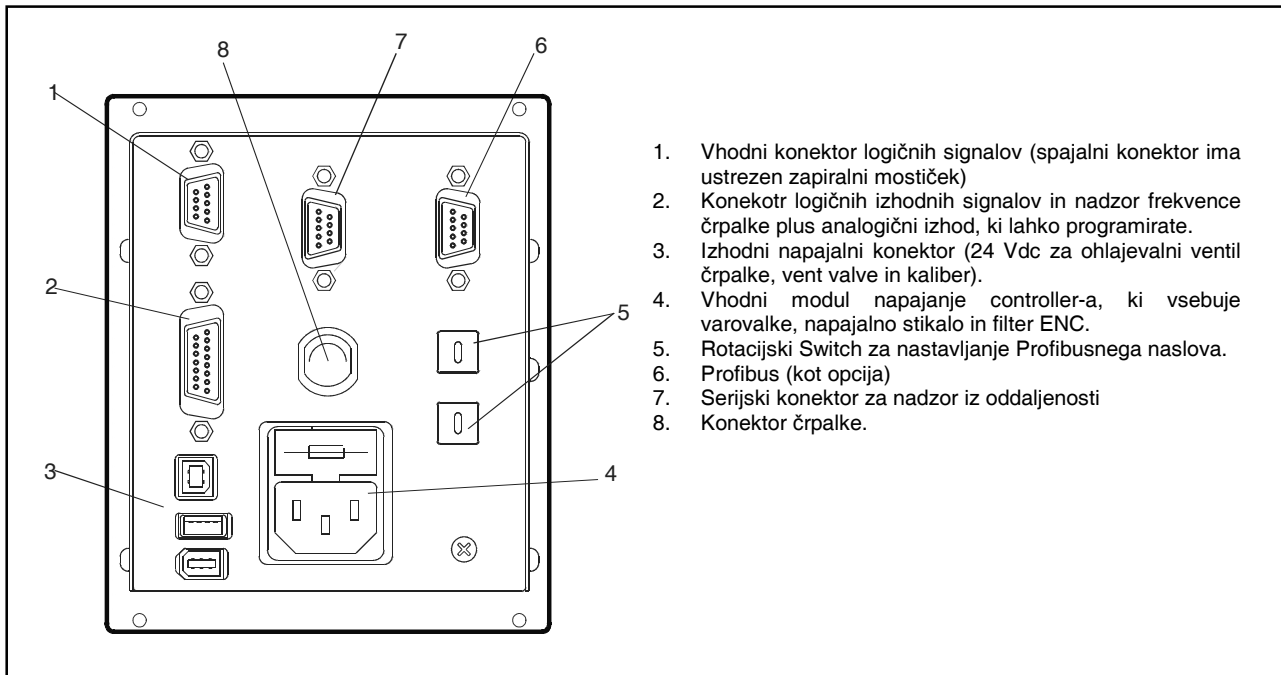

Ozadnja plošča Controllera Turbo-V 301-AG

## POSTOPKI UPORABE

### Vklopitev Controllera

Za vklopitev controllera, priključite napajalni kabel v omrežno vtičnico.

### Zagon črpalke

Da bi zagnali črpalko morate usposobiti vhod interlock-a in pitisniti tipko START na prednji plošči.

### Zaustavitev črpalke

Zaustavite črpalko s tipko STOP na prednji plošči.

## VZDRŽEVANJE

Controllerji serije Turbo-V 301 Rack ne potrebujejo vzdrževanja. Samo pooblaščen osebje lahko rokuje s to napravo.

V slučaju okvare se lahko obrnete servisu Varian ali "Varian advanced exchange service", ki vam stavlja na razpolago obnovljeni controller-a.



**SVARILO!**

Pred katerikoli posegom, zključite napajalni kabel iz controllera.

Controller zavrzite kot industrijski odpadek v skladu z državnimi predpisi.

## ODLAGANJE OPADKOV

### Pomen znamke "WEEE" na etiketah.

Spodaj navedeni simbol je v skladu z direktivo ES znano pod imenom "WEEE".

Ta simbol (**ki velja samo v državah Evropske Skupnosti**) pomeni, da izdelek **NE SMETE ODSTRANITI** skupaj z ostalimi komunalnimi ali pa industrijskimi odpadki, temveč morate poskrbeti za njihovo primerno ločevanje.

Zato pozivamo uporabnike, da se ali pri prodajalnem centru ali pa pri prodajalcu seznanijo o postopku ločevanja in odstranitve odpadkov, šele nato, ko se je seznanil s pogoji in z merili kupopordajne pogodbe.

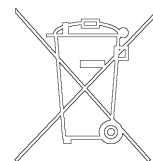

**OBVESTILO O NAPAKI**

V nekaterih slučajih kvara pokaže električno vezje avtodiagnoze controller-a nekaj obvestil o napakah kot so opisane v spodnji tabeli.

OBVESTILO	OPIS	POPRAVA
<b>CHECK CONNECTION TO PUMP</b>	Napaka v priključitvi črpalke in controller-a. Ali Črpalka ima nižjo temperaturo od 0 °C.	Preverite, da je priključni kabel med črpalke in controller-em na obeh koncih trdno pritrjen in da ni prekinjen. Dvakrat pritisnite tipko START za ponoven zagon črpalke.
<b>WAITING INTERLOCK</b>	Signal interlocka prisoten na konektorju P1 zaradi prekinitve kratkega stika med pinom 3 in pinom 8 konektorja J1, ali ker se je odprl signal zunanega interlocka.	Ponovno nastavite kratki stik med pinom 3 in pinom 8 konektorja J1, ali zaprite signal zunanega interlocka.
<b>PUMP OVERTEMP.</b>	Temperatura gornjega ležišča ali črpalke je presegla i 60 °C.	Počakajte, da se temperatura vrne pod normalnim vrednostnim pragom. Pritisnite dvakrat tipko START za ponoven zagon črpalke.
<b>CONTROLLER OVERTEMP.</b>	Temperatura controllera je presegla 70 °C. Ali Temperatura controllerskega radiatorja je višja od 60 °C.	Počakajte, da se temperatura vrne pod normalnim vrednostnim pragom. Dvakrat pritisnite tipko START za ponoven zagon črpalke.
<b>TOO HIGH LOAD</b>	Tok, ki ga črpalka prejme je večji od programiranega.	Preverite, da lahko rotor črpalke prosto vrti. Dvakrat pritisnite tipko START za ponoven zagon črpalke.
<b>SHORT CIRCUIT</b>	Med navadnim delovanjem (po zagonu) je priklopitev na izhodu v kratkem stiku.	Preverite priključke črpalke in controllera. Dvakrat pritisnite tipko START za ponoven zagon črpalke.
<b>SYSTEM OVERRIDE</b>	Delovanje črpalke je zaustavil signal zasilnosti iz oddaljenega kontakta.	Izklopite napajalni kabel controllera in popravite napako, ki se je pojavila s signalom zasilnosti. Ponovno priključite napajalni kabel in pritisnite dvakrat tipko START za ponoven zagon črpalke.
<b>OVERVOLTAGE</b>	Kvar v oddelku za napajanje controllera, ali je controller dobil nepristen znak.	Dvakrat pritisnite tipko START za ponoven zagon črpalke. Če se to obvestilo spet pojavi, obrnite se Varian za pravilno vzdrževanje.
<b>POWER FAIL</b>	Kvar v oddelku napajanja črpalke, controllera.	Obrnite se Varian za pravilno vzdrževanje.

**GENERAL INFORMATION**

This equipment is destined for use by professionals. The user should read this instruction manual and any other additional information supplied by Varian before operating the equipment. Varian will not be held responsible for any events occurring due to non-compliance, even partial, with these instructions, improper use by untrained persons, non-authorized interference with the equipment or any action contrary to that provided for by specific national standards. The Turbo-V 301-AG Rack controllers are micro-processor-controlled, solid-state, frequency converter with self-diagnostic and self-protection features.

Controller features:

- Front / Remote / Serial Operation
- 24Vdc pump fan cooling drive
- Vent valve drive
- Pump speed reading after stop command (stop speed reading)
- Pressure reading
- Input voltage auto setting.
- Profibus interface (optional)

The following paragraphs contain all the information necessary to guarantee the safety of the operator when using the equipment. Detailed information is supplied in the appendix "Technical Information".

**This manual uses the following standard protocol:**



**WARNING!**

The warning messages are for attracting the attention of the operator to a particular procedure or practice which, if not followed correctly, could lead to serious injury.



**CAUTION!**

The caution messages are displayed before procedures which, if not followed, could cause damage to the equipment.

**NOTE**

*The notes contain important information taken from the text.*

**STORAGE**

When transporting and storing the controllers, the following environmental requirements should be satisfied:

- temperature: from -20 °C to + 70 °C
- relative humidity: 0 - 95%  
(without condensation)

**PREPARATION FOR INSTALLATION**

The controller is supplied in a special protective packing. If this shows signs of damage which may have occurred during transport, contact your local sales office. When unpacking the controller, ensure that it is not dropped or subjected to any form of impact. Do not dispose of the packing materials in an unauthorized manner. The material is 100% recyclable and complies with EEC Directive 85/399.

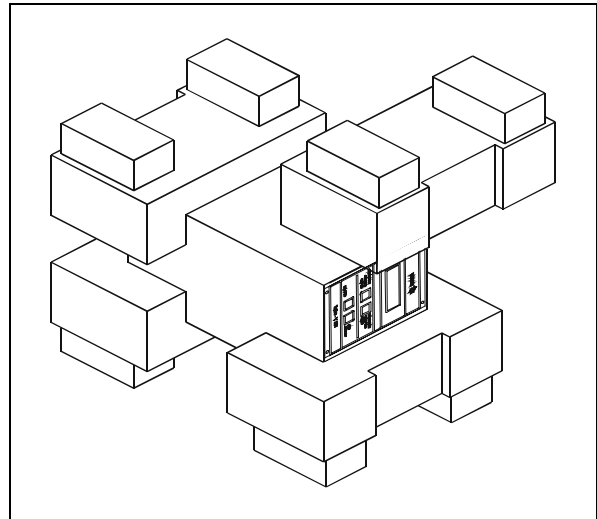

*Controller Packing*

**INSTALLATION**



**WARNING!**

The Turbo-V controller must be powered with 3-wire power cord (see orderable parts table) and plug (internationally approved) for user's safety. Use this power cord and plug in conjunction with a properly grounded power socket to avoid electrical shock and to satisfy CE requirements. High voltage developed in the controller can cause severe injury or death. Before servicing the unit, disconnect the input power cable.

**NOTE**

The Turbo-V controller can be used as a bench unit or a rack module, but it must be positioned so that free air can flow through the holes. Do not install or use the controller in an environment exposed to atmospheric agents (rain, snow, ice), dust, aggressive gases, or in explosive environments or those with a high fire risk.

During operation, the following environmental conditions must be respected:

- temperature: from 5 °C to +45 °C
- relative humidity: 0 - 95% (without condensation)

See the appendix "Technical Information" for detailed information about the above mentioned and the other connections, and about the options installation.

**USE**

This paragraph describes the fundamental operating procedures. Detailed information and operating procedures that involve optional connections or options are supplied in the paragraph "USE" of the appendix "Technical Information".

Make all vacuum manifold and electrical connections and refer to Turbo-V pump instruction manual prior to operating the Turbo-V controller.



**WARNING!**

To avoid injury to personnel and damage to the equipment, if the pump is lying on a table make sure it is steady. Never operate the Turbo-V pump if the pump inlet is not connected to the system or blanked off.

**NOTE**

The input signal J1 connector should be left in position including the shipping links if no external connections are made. The forepump and the Turbo-V pump can be switched on at the same time.

**Controls, Indicators and Connectors**

The following paragraph illustrates the Controller front panel and rear panel. More details are contained in the appendix "Technical Information".

**Front Panel Description**

The diagram shows the front panel of the Turbo-V 301-AG controller. At the top is the VARIAN logo. Below it is a dot matrix LCD display (callout 5) showing 'LS AG' on the left and 'R1 R2' on the right. Under the display is a keyboard with several buttons: 'increase' (callout 1), 'decrease' (callout 2), 'menu', 'next' (callout 3), 'previous', and 'START/STOP' (callout 4). The text 'VACUUM TECHNOLOGIES' is printed above the keyboard, and 'Turbo-V 301-AG' is printed below it.

1. Keyboard push-button to recall on the display the cycle number, cycle time and pump life.
2. Keyboard push-button for LOW SPEED mode selection. It is active only when the front panel operation has been selected. Pressed once, the pump runs at "stand-by" speed. To unselect the mode, press the push-button again.
3. Keyboard push-button to recall on the display the pump current, pump temperature, pump power and rotational speed. It is always active regardless of the operating mode selected. Push-buttons 3 and 1, if pressed together for at least 2 seconds, put the controller in a routine where it is possible to program some operation parameters.
4. Keyboard push-button for START, STOP/RESET mode selection. It is active only when the front panel operation has been selected. By pressing once the starting phase begins; if pressed again it stops the pump. If the pump has been stopped automatically by a fault, this push-button must be pressed once to reset the controller and a second time to restart the pump.
5. LCD back-lighted alphanumeric display: dot matrix 2 lines x 16 characters.

Controller Turbo-V 301-AG Front Panel



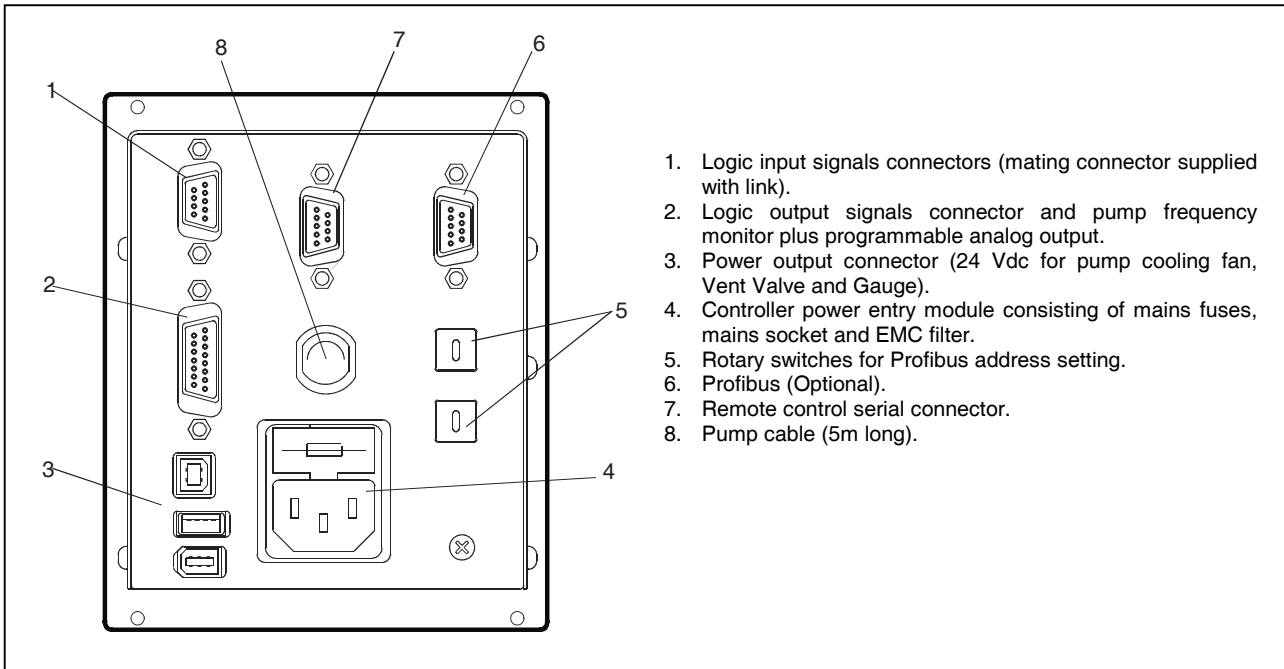

1. Logic input signals connectors (mating connector supplied with link).
2. Logic output signals connector and pump frequency monitor plus programmable analog output.
3. Power output connector (24 Vdc for pump cooling fan, Vent Valve and Gauge).
4. Controller power entry module consisting of mains fuses, mains socket and EMC filter.
5. Rotary switches for Profibus address setting.
6. Profibus (Optional).
7. Remote control serial connector.
8. Pump cable (5m long).

*Controller Turbo-V 301-AG Rear panel*

**USE PROCEDURE**

**Controller Startup**

To startup the controller plug the power cable into a suitable power source.

**Starting the Pump**

To start the pump, confirm the interlock input and press the START pushbutton on the controller front panel.

**Pump Shutdown**

To shutdown the pump press the STOP pushbutton on the controller front panel.

**MAINTENANCE**

The Turbo-V 301-AG Rack series controller does not require any maintenance. Any work performed on the controller must be carried out by authorized personnel.

When a fault has occurred it is possible to use the Varian repair service. Replacement controllers are available on an advance exchange basis through Varian.



**WARNING!**

Before carrying out any work on the controller, disconnect it from the supply.

If a controller is to be scrapped, it must be disposed of in accordance with the specific national standards.

**DISPOSAL**

**Meaning of the "WEEE" logo found in labels**

The following symbol is applied in accordance with the EC WEEE (Waste Electrical and Electronic Equipment) Directive.

This symbol (**valid only in countries of the European Community**) indicates that the product it applies to must NOT be disposed of together with ordinary domestic or industrial waste but must be sent to a differentiated waste collection system.

The end user is therefore invited to contact the supplier of the device, whether the Parent Company or a retailer, to initiate the collection and disposal process after checking the contractual terms and conditions of sale.

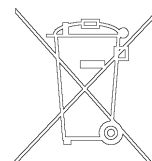

**ERROR MESSAGES**

For a certain type of failure, the controller will self-diagnose the error and the messages described in the following table are displayed.

<b>MESSAGE</b>	<b>DESCRIPTION</b>	<b>REPAIR ACTION</b>
<b>CHECK CONNECTION TO PUMP</b>	Wrong connection between the pump and the controller. Or The pump's temperature is below 0 °C.	Check connection between controller and pump. Press the START push-button twice to start the pump.
<b>WAITING INTERLOCK</b>	The interlock signal of P1 connector is activated by an interruption of the link between pin 3 and 8 of J1 connector, or because the external interlock signal is open.	Reset the short circuit between pin 3 and pin 8 of J1 connector, or close the external interlock signal.
<b>PUMP OVERTEMP.</b>	The upper bearing/pump temperature exceeds 60 °C.	Wait until the temperature decrease below threshold value. Press the START push-button twice to start the pump.
<b>CONTROLLER OVERTEMP.</b>	The controller environment temperature exceeds 70 °C. Or The controller's radiator temperature is above 60 °C.	Wait until the temperature decrease below threshold value. Press the START push-button twice to start the pump.
<b>TOO HIGH LOAD</b>	The current drawn by the pump is higher than programmed.	Check that the pump rotor is free to rotate. Press the START push-button twice to start the pump.
<b>SHORT CIRCUIT</b>	After the starting phase the output connection is shorted.	Check connections and shortages between pump and controller. Press the START push-button twice to start the pump.
<b>SYSTEM OVERRIDE</b>	The pump is stopped by an emergency stop signal provided via a remote contact.	Remove the controller power cable and check the emergency condition. Then reconnect the power cable and press the START push-button twice to start the pump.
<b>OVERVOLTAGE</b>	Controller power supply circuitry is faulty, or the Controller received a spike.	Press the START push-button twice to start the pump. Should the message still be present, call the Varian service.
<b>POWER FAIL</b>	Failure in the controller's pump power supply section.	Contact Varian for Maintenance.

**TURBO-V 301 RACK CONTROLLER  
DESCRIPTION**

The controller is available in three models (see orderable parts table):

- base version
- with RS 232-485 option
- with Profibus option

The controller is a solid-state frequency converter with the following features:

- Drives the pumps of the 301-NAV family.
- Powers the pump cooling fan
- Drives the vent valve.
- Provides and acquires the pressure of the wide range gauge.
- Remote I/Os compatible with the previous version.
- Navigator default serial compatible with the previous RS 232 and 485 version.
- Speed reading after stop command.

See the following diagram for the connections and orderable parts.

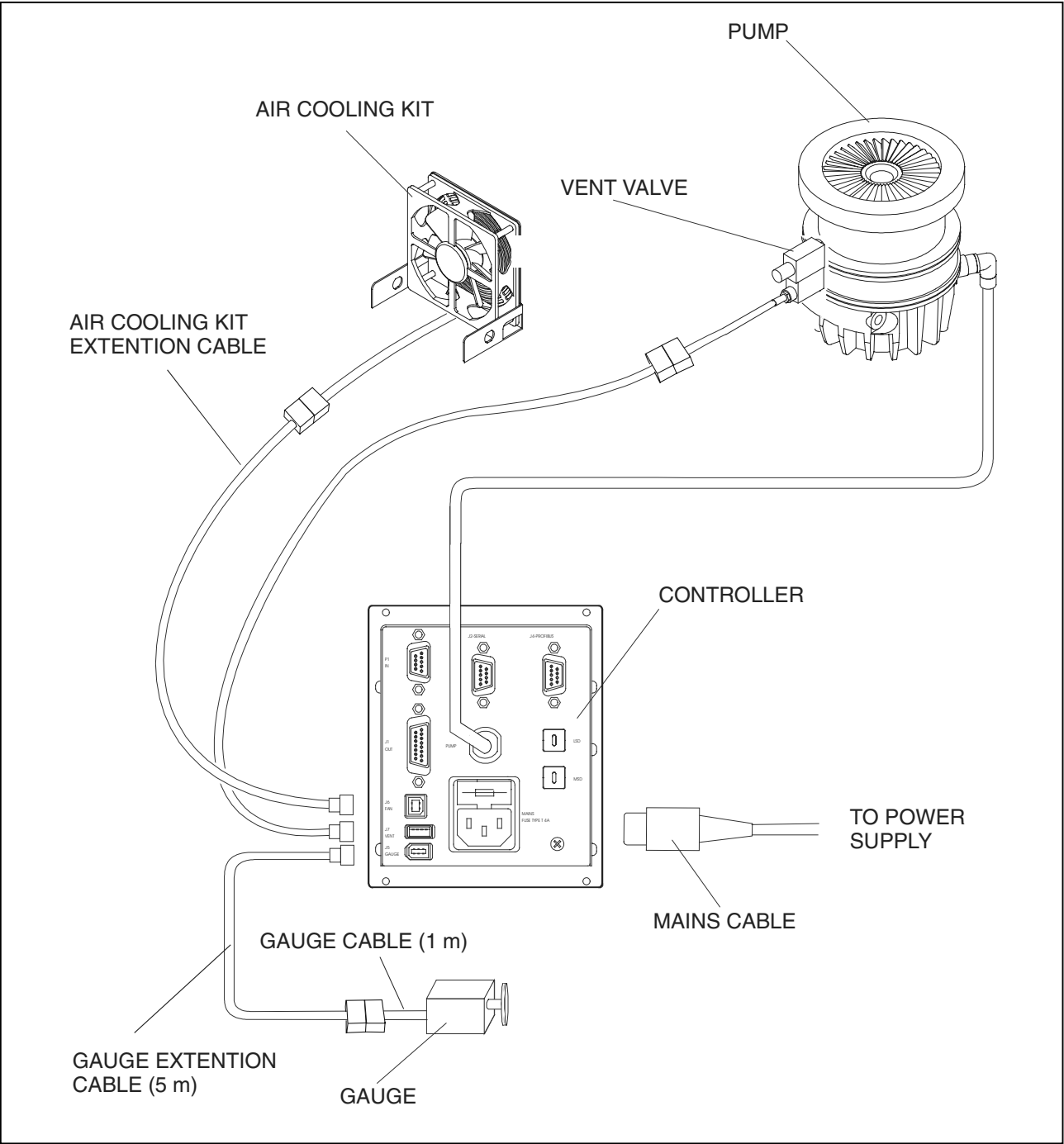

*Turbo-V 301-AG Rack Controller – Connections*

**CONTROLLER SPECIFICATIONS**

<b>Input:</b>	
Voltage	100, 240 Vac
Frequency	50 to 60 Hz
Power	350 VA
<b>Fuse</b>	2 x T4 A (slow blow) 250 V
<b>Output:</b>	
Voltage	75 Vac
Frequency	963 Hz
Power	150 W
<b>Environment storage</b>	-20 °C to +70 °C 0-95%
<b>Operating</b>	+5 - +45 °C 0 – 90%

<b>Applied norr.</b>	EN 61010 -1 EN 55011 (Class-A) EN 61000-3-2, EN 61000-3-3, EN 61000-6-2, EN 61000-4-2,3,4,5,6,11, 8
<b>Weight:</b>	1.7 Kg (3.2 lbs)
<b>Pollution Degree</b>	2
<b>Installation Category</b>	II

**CONTROLLER OUTLINE**

The outline dimensions for the Turbo-V 301 Rack controllers are shown in the following figure.

**NOTE**

The Controller must be positioned in such way that the mains cable can be easily disconnected.

**NOTE**

The Turbo-V controller can be used as a bench unit or as a rack module, but it must be positioned so that free air can flow through the holes.

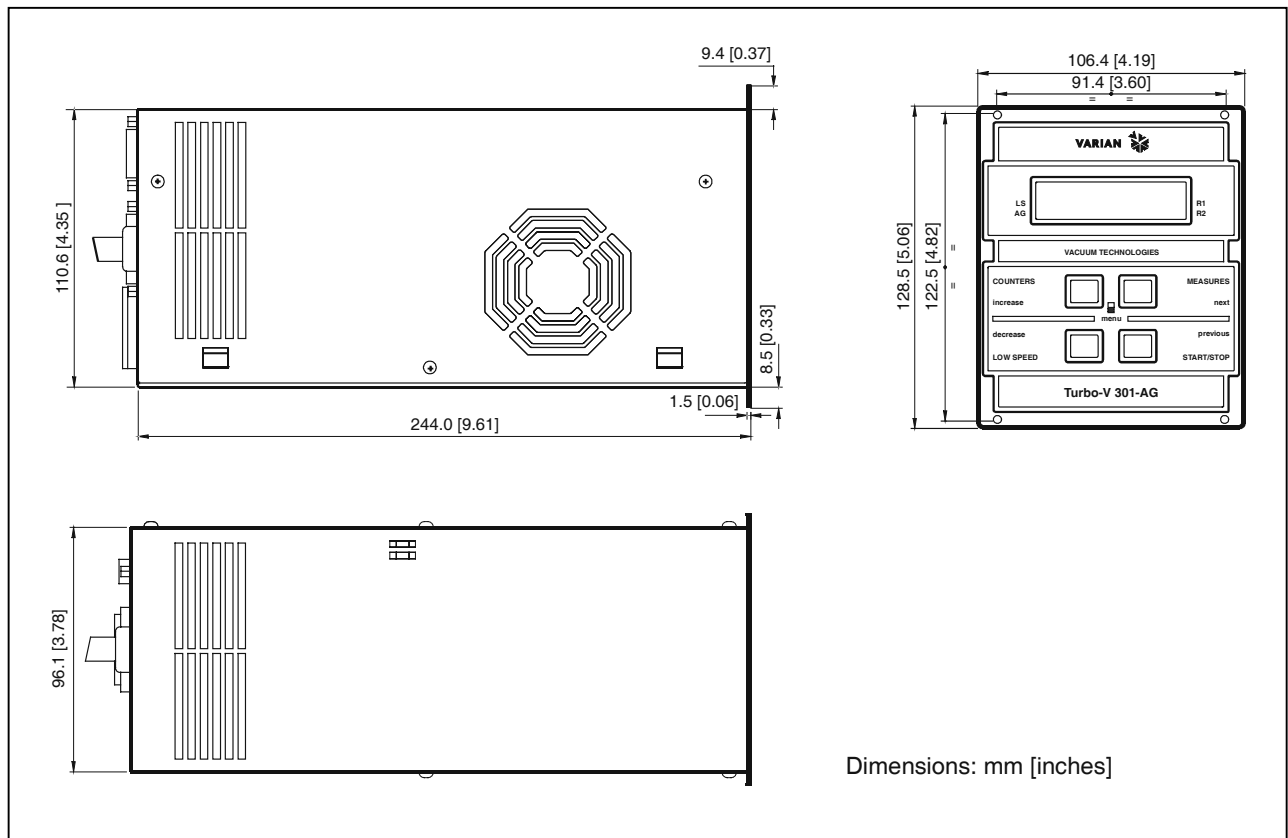

Dimensions: mm [inches]

Controller Outline

**CONTROLLER CONNECTION**

**J6 – Fan**

The 24 Vdc, 150 mA maximum output voltage is present after START pushbutton is pressed and will remain present until a fault condition is displayed on front panel display or the turbopump is stopped. This is a dedicated output for the optional Turbo-V 301 pump cooling fan (see orderable parts table).

If you already have fan installed, use the available adapter cable to connect to the pump.

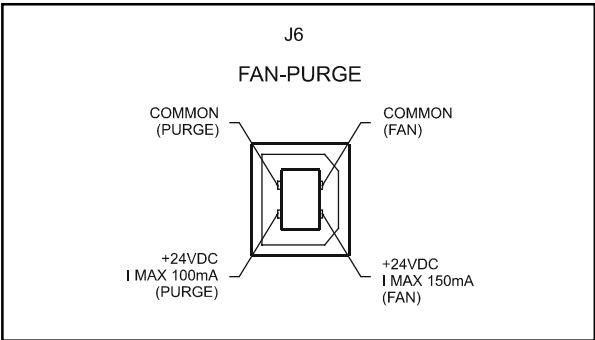

Fan Connector

**J7 – Vent**

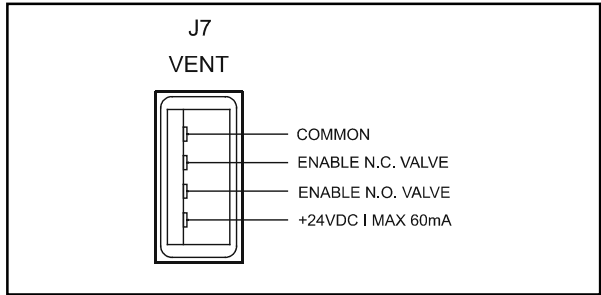

Vent Connector

This is dedicated 24 Vdc connector to control the optional vent valve (see orderable parts table). The vent valve can be driven by controller automatically or by serial line.

If you already have a vent valve installed 110 Vac powered, this valve must be replaced by a new model (see orderable parts table).

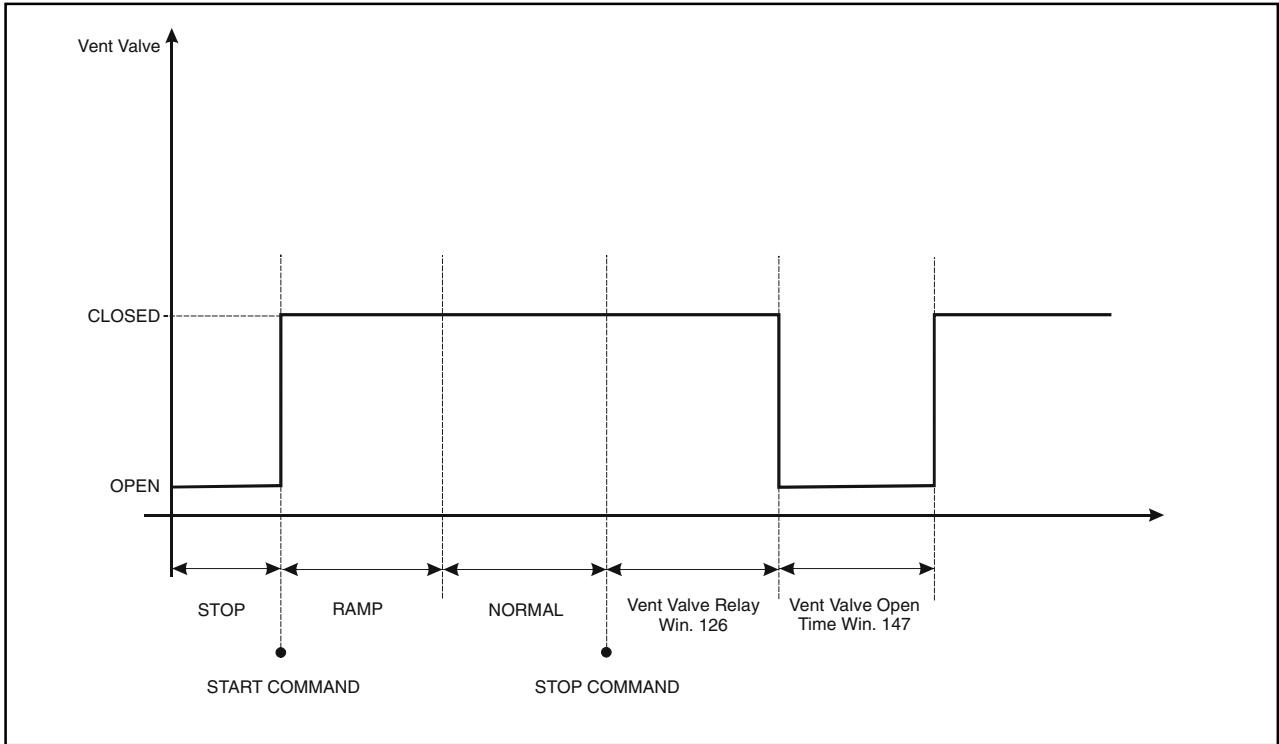

Vent Valve diagram in "Auto" mode

**P1 – Input**

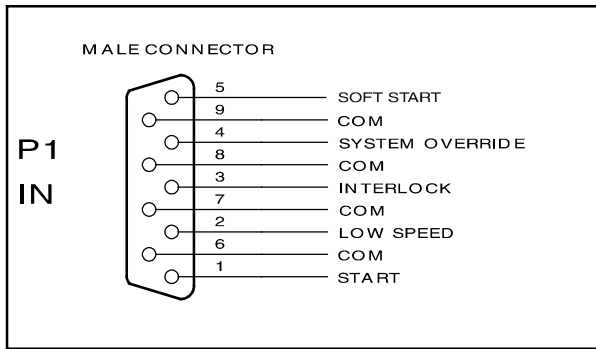

*P1 Input Connector*

All the logic input to the controller **must** be connected at J1 mating connector.

With the provided J1 mating connector (shipped with pin 3 and pin 8 shorted) make the connections with AWG 24, (0.24 mm<sup>2</sup>) or smaller wire to the pins indicated in the figure to obtain the desired capability.

The following table describes the signals available on the connector.

Pins	Name	Description	Electrical	Note
1-com	Start/Stop	Contact closed = Start Contact open = Stop	Optically isolated Vlow, max = 10v Imax = 5mA  Imin (on) = 2mA	Active only in Remote Mode operation
2-com	Low Speed	Contact closed = Low Speed Contact open = High Speed	Optically isolated Vlow, max = 10v Imax = 5mA	Active only in Remote Mode operation
3-com	Interlock	Contact closed = Active Contact open = Inactive  If active allows the pump running, if inactive stops the pump.	Optically isolated Vlow, max = 10v Imax = 5mA  Imin (on) = 2mA	Active in all modes
4-com	System Override	Contact closed = Active Contact open = Inactive  If active allows the pump running, if active stops the pump and all the others connected devices (Fan, Vent Valve...).	Optically isolated Vlow, max = 10v Imax = 5mA  Imin (on) = 2mA	Active in all modes
5-com	Soft Start	Contact closed= Active Contact open= Inactive  If active before the start command activates the spt start procedure. To be used only at first pump run-up.	Optically isolated Vlow, max = 10v Imax = 5mA Imin (on) = 2mA	Active only in Remote Mode operation, and in STOP status.

The following figure shows a typical contact logic input connection and the related simplified circuit of the controller.

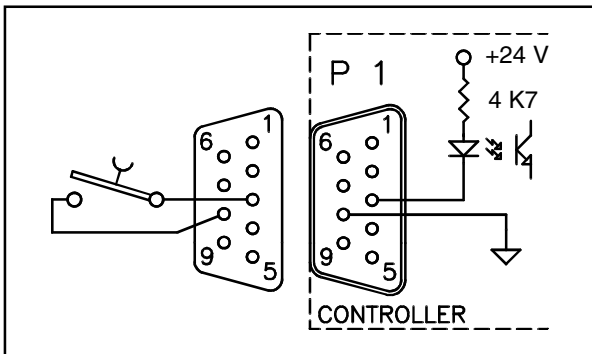

Typical Logic Input Connection

J1 – Output

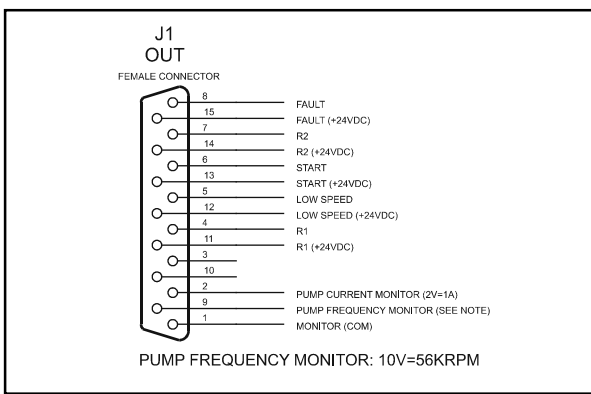

Logic Output Connector

All the logic output from the controller must be connected at P2 mating connector. The following table describes the signals available on the connector.

Pins	Name	Description	Electrical	Note
15-8	Fault	0V = no fail 24V = fail	Optically isolated Vmax (=open) = 24v Vlow, max = 1,5v Imax = 60mA Pin-8 negative Pin-15 positive	Connect a 10kohm resistor between the 2 pins before measuring voltage A STOP command (by front Panel or serial or Start/stop input) reset the FAIL status.
13-6	Start	Configurable output. Default setting (win.177 = 0): 24V pump in RAMP state, 0V = other state. If win.177 = 1: 0V = pump in stop or FAIL status, 24V = other state	Optically isolated Vmax (=open) = 24v Vlow, max = 1,5v Imax = 60mA Pin-6 negative Pin-13 positive	Connect a 10kohm resistor between the 2 pins before measuring voltage
12-5	Low Speed	24V = low speed active 0V = low speed not active	Optically isolated Vmax (=open) = 24v Vlow, max = 1,5v Imax = 60mA Pin-5 negative Pin-12 positive	Connect a 10kohm resistor between the 2 pins before measuring voltage
11-4	R1	Programmable Set Point Out Can be related to: Frequency, Power, Time Status or Pressure. See following figures for more details. All the setting can be done by: front panel or serial line (win.101 to 105 and 162).	Optically isolated Vmax (=open) = 24v Vlow, max = 1,5v Imax = 60mA Pin-5 negative Pin-12 positive	Connect a 10kohm resistor between the 2 pins before measuring voltage

The following figure shows a typical logic output connection (relay coil) but any other device may be connected e.g. a LED, a computer, etc., and the related simplified circuit of the controller.

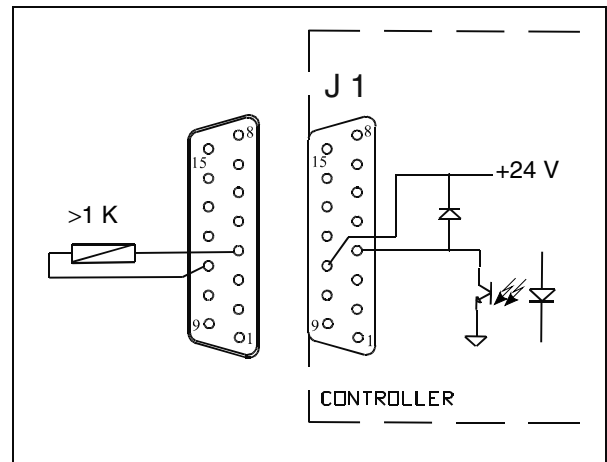

Digital Output Connection Example

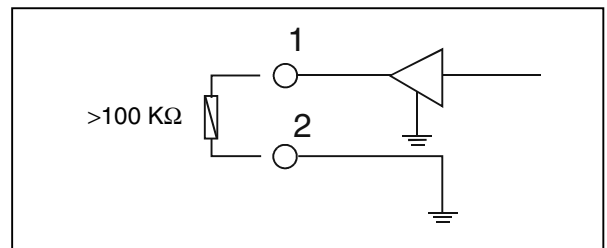

Analog Output Connector Example

Pins	Name	Description	Electrical	Note
14-7	R2	Programmable Set Point Out Can be related to: Frequency, Power, Time Status or Pressure. See following figures for more details. All the setting can be done by: front panel or serial line (win.171 to 176).	Optically isolated Vmax (=open) = 24v Vlow, max = 1,5v Imax = 60mA Pin-7 negative Pin-14 positive	Connect a 10kohm resistor between the 2 pins before measuring voltage
2-1	Programmable Analog Output	Programmable analog output. Can be related to : frequency, power, pump temperature (linear) or pressure (logarithmic). The setting can be done by: front panel or serial line (win.111). 0V = 0Hz, 0W, 0°C 10V = 963Hz, 150W, 100°C See following chart for more details	Optically isolated Rload, min = 10kr Ripple Vpp,max = 200mv Precision = 5% Resolution = 40mv Pin-1 negative Pin-2 positive	Connect a 100kohm resistor between the 2 pins before measuring voltage
9-1	Frequency Analog Output	Analog output proportional to frequency (linear). 0V = 0Hz 10V = 963Hz	Optically isolated Rload, min = 10kr Ripple Vpp,max = 200mv Precision = 1% Resolution = 40mv Pin-1 negative Pin-9 positive	

**R1 – R2 OUTPUT DIAGRAMS:**

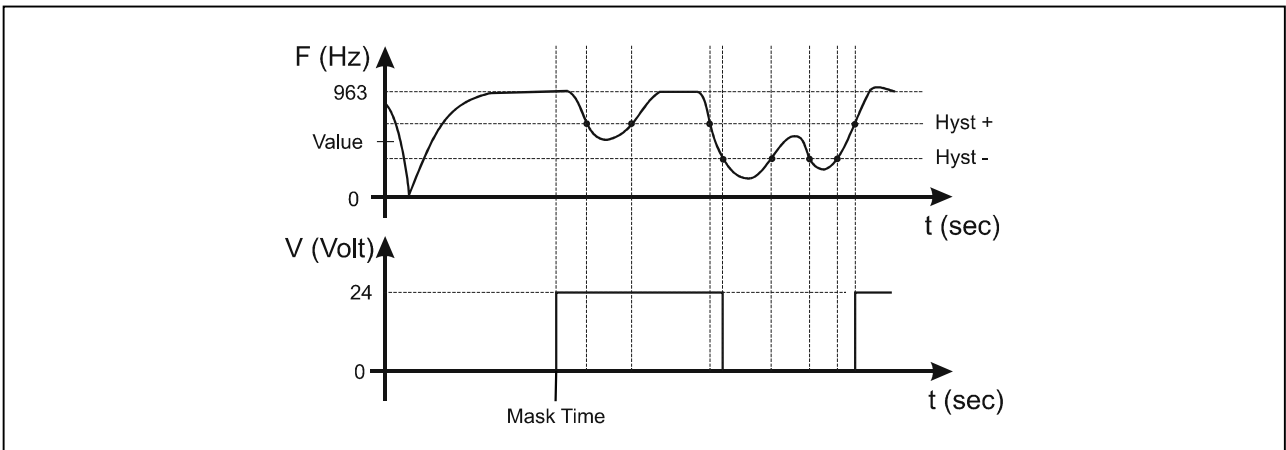

Diagram 1 – R1 or R2 related to frequency

+

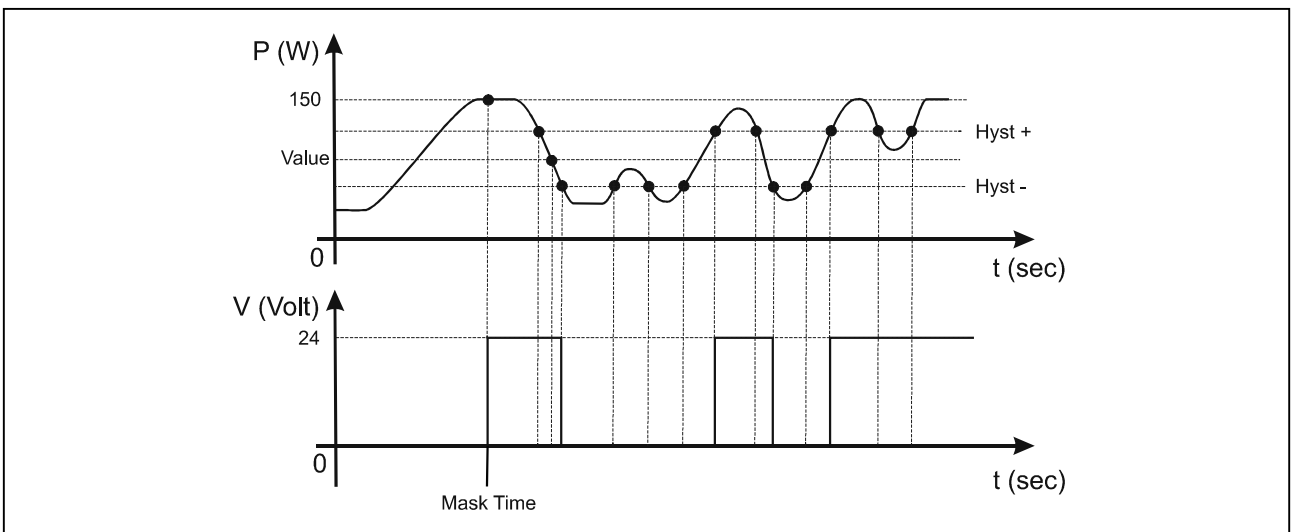

Diagram 2 – R1 or R2 related to power



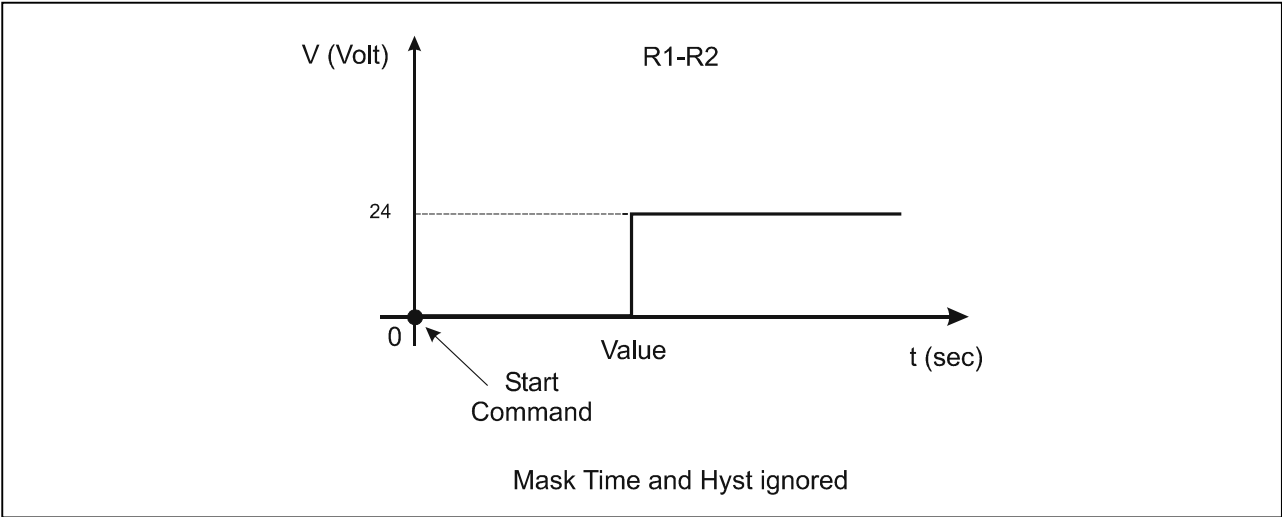

Diagram 3 – R1 or R2 related to time

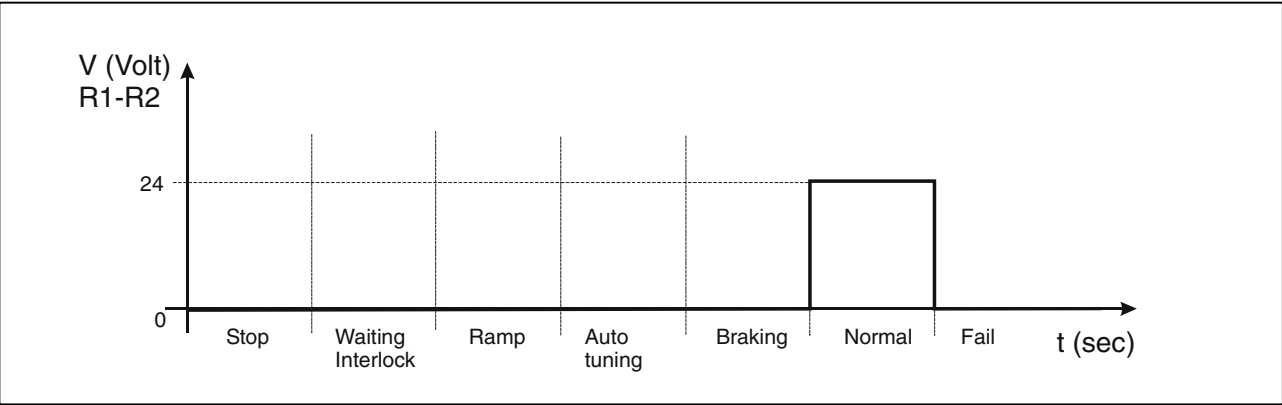

Diagram 4 – R1 or R2 related to Normal status

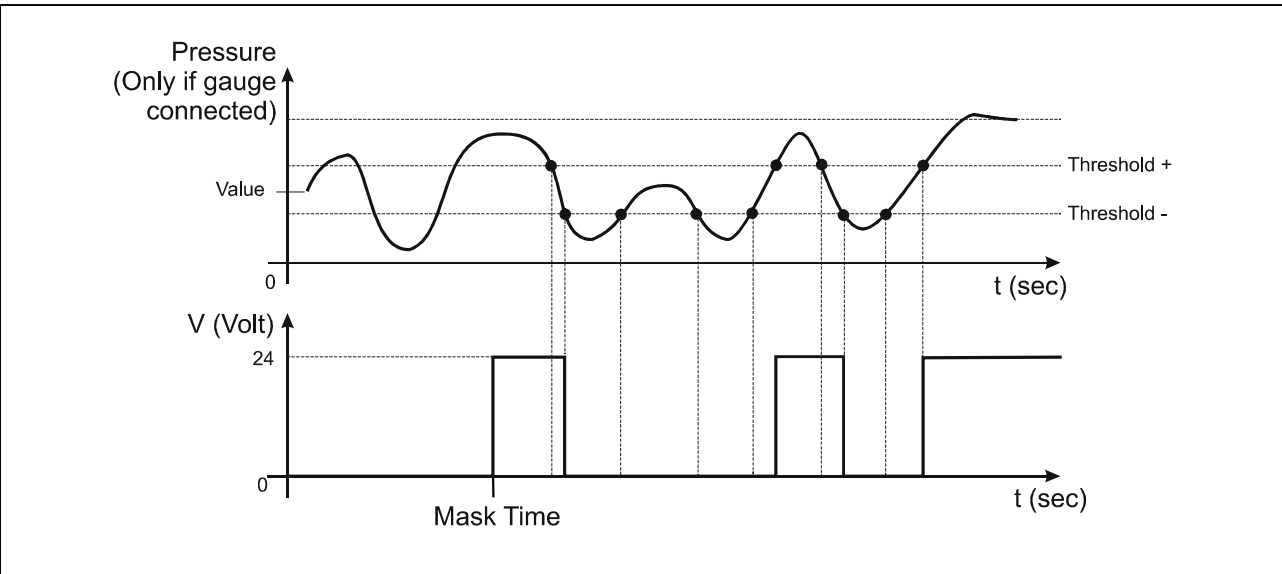

Diagram 5 – R1 or R2 related to pressure reading (if gauge connected)

PROGRAMMABLE ANALOG OUTPUT DIAGRAMS:

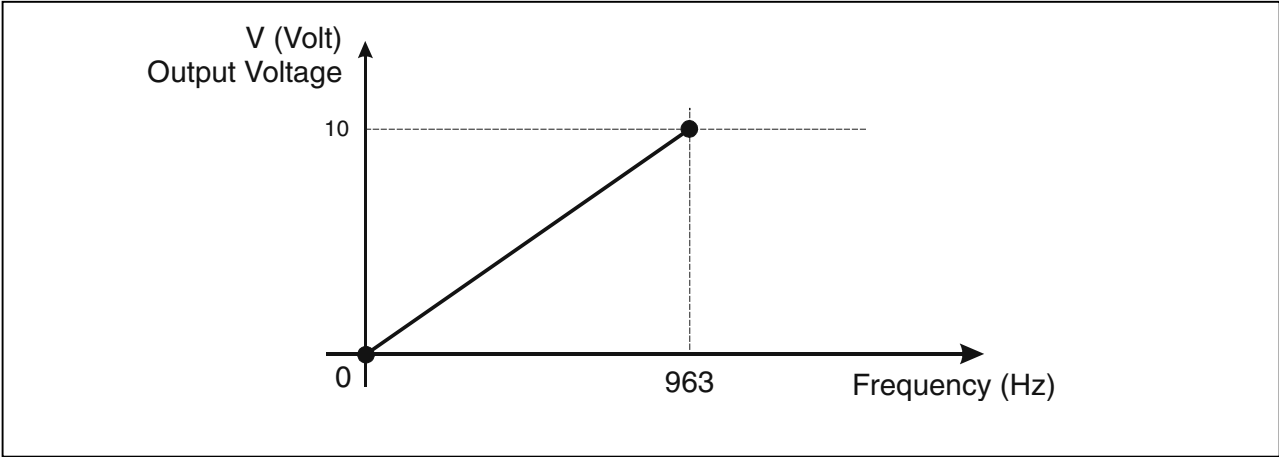

Diagram 1 – Programmable analog output related to frequency

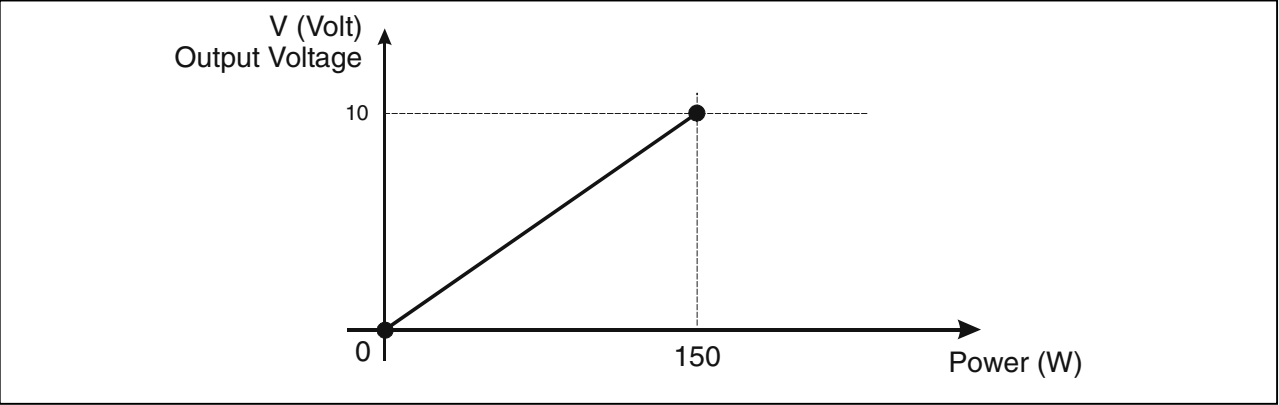

Diagram 2 – Programmable analog output related to power

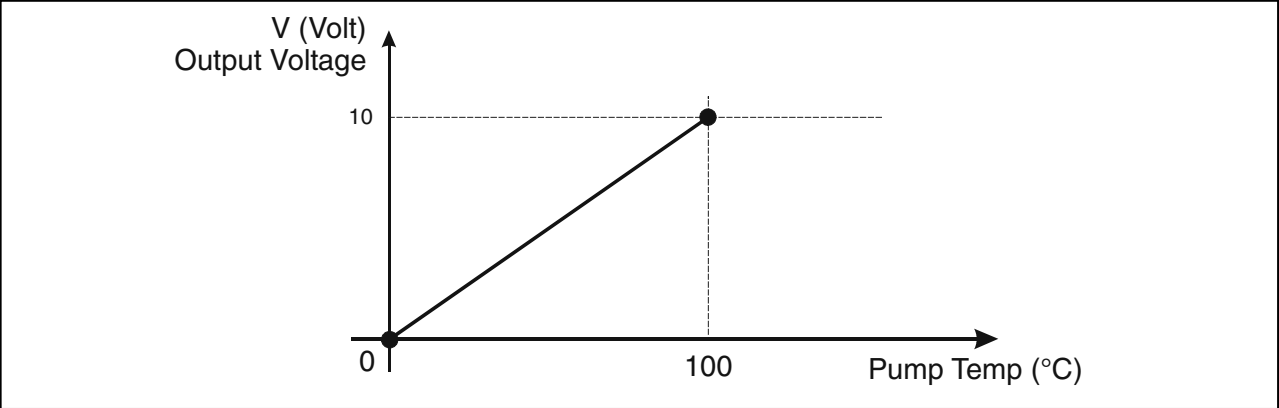
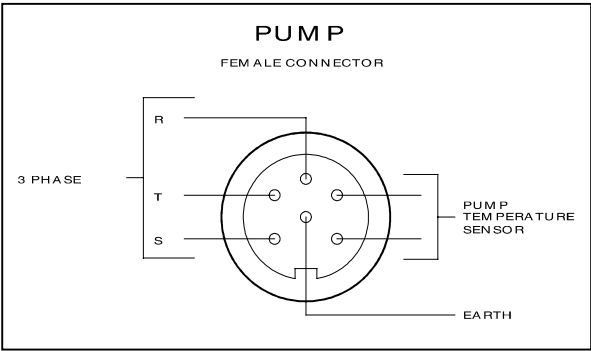

Diagram 3 – Programmable analog output related to pump temperature

**Pump Connector**

A five-meter long cable is available to connect the controller to the pump. The following figure shows the controller output connector configuration where pins:

- A-F = pump temperature sensor
- B-C-D = 75 Vac 3-phase output to pump motor stator
- E = EARTH PROTECTION



Controller-to-Pump Connector

**J5 – GAUGE CONNECTOR**

This connector is available to connect “EyeSys Mini-IMG” gauge with its extension cable (see orderable parts table).

The pressure can be read by display or by serial line (win. 224) or by REMOTE I/O on Programmable Analog Out (in this case the controller replicates the signal coming from the gauge).

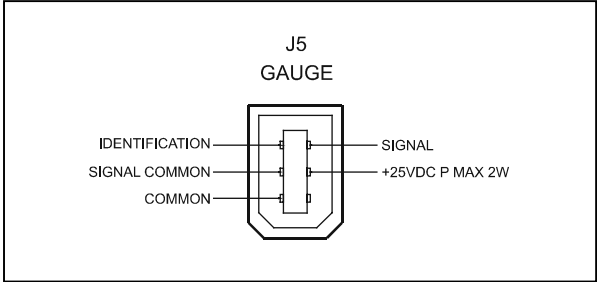

Gauge Connector

**NOTE**

The Mini-IMG gauge is intended for high vacuum use, so with pressure above 50 mTorr the signal is misinterpreted and a “false” pressure is displayed. Use a transition gauge to understand if the reading is really under 50 mTorr or not.

**Pump Driving**

Typical pump driving chart start and normal operation.

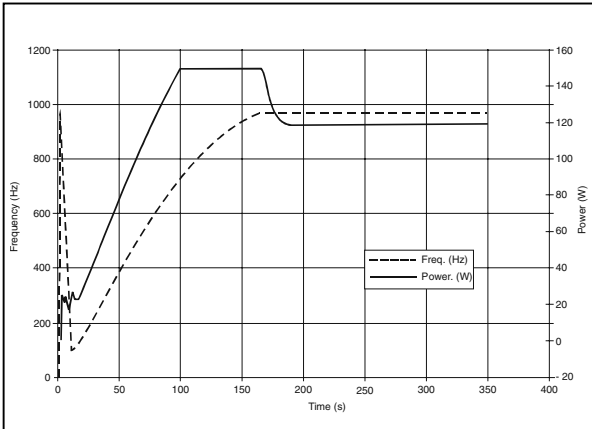

Diagram 4

**Stop Speed Reading and Active Stop**

This functions can be activated by Front Panel or serial line (Win 107, 167).

Active Stop brakes the pump using the motor. The Stop Speed reading reads the pump speed after a stop command.

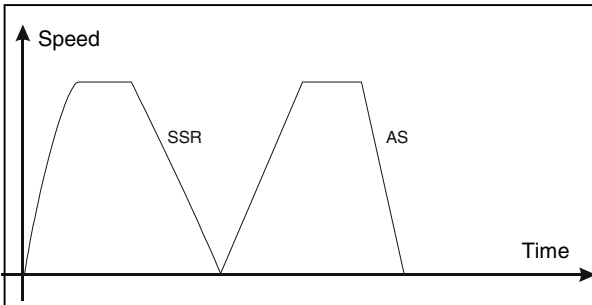
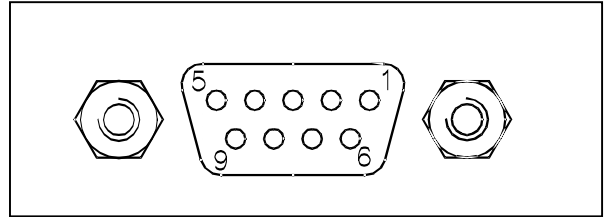

Diagram 5

**J2 – SERIAL CONNECTOR**

This connector provides the connection for RS – 232 and RS – 485 serial line.

J2 Pin-out:



PIN N.	SIGNAL NAME
1	+5 V (OUT) (Reserved)
2	TX (RS232)
3	RX (RS232)
4	NC
5	GND
6	A + (RS485)
7	NC
8	B – (RS485)
9	RESERVED

**Connector examples:**

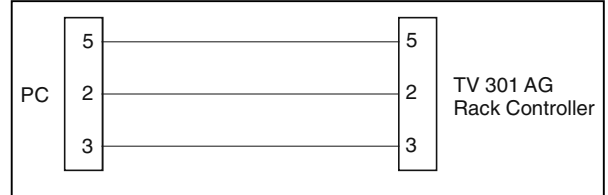

RS – 232 Connection

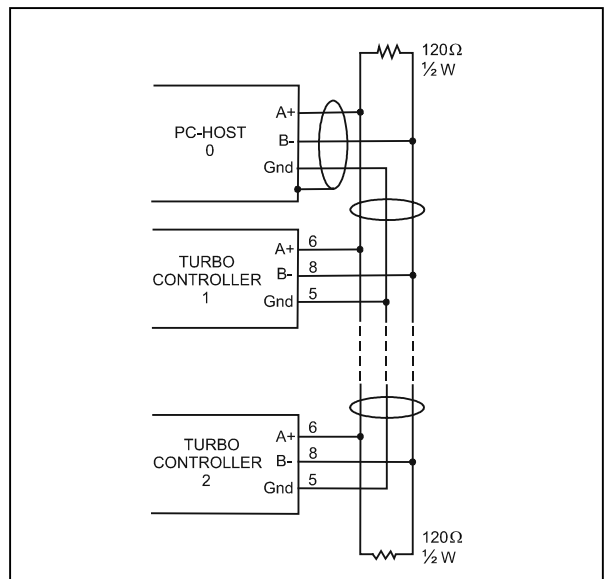

RS – 485 Connection

The communication port mating connector is supplied with the RS 232 PCB (AMP/Cannon or equivalent 15-pin "D" type male connector).

For example, the Transmit data signal from controller (pin 2) must be connected to the host computer's receive data line (pin 2) and vice versa. Consult the host computer's instruction manual for its serial port connections.

---

**NOTE**

*Varian cannot guarantee compliance with FCC regulations for radiated emissions unless all external wiring is shielded, with the shield being terminated to the metal shroud on the 0-subconnector. The cable should be secured to the connector with screws.*

---

**Serial Communication Descriptions**

This unit can communicate by two different protocols:

- protocol (old system) "letter"
- "Window" protocol (new system)

These two protocols can be used as well with 232 or 485 media.

---

**NOTE**

Please use "Window" protocol for new development.

---

**LETTER PROTOCOL DESCRIPTION:**

The default protocol is "Window"

Communication format:

- 8 data bit
- no parity
- 1 stop bit
- The baud rate is programmable via front panel from 600 to 9600 baud. The controller is factory-set for 9600 baud operation.

Communication protocol:

Host = Master

Turbo-V 301 Controller = Slave

The communication is performed in the following way:

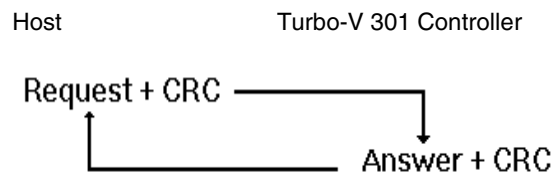

**Request** is an ASCII character identifying the action that must be performed by the controller or the requested information.

Allowed ASCII characters:

- "A" = START
- "B" = STOP
- "C" = Low Speed ON
- "D" = Low Speed OFF
- "E" = Request for operational parameters
- "F" = Pump times zeroing
- "G" = Parameters reading
- "H" = Parameters writing
- "I" = Request for operating status
- "J" = Request for numerical reading
- "K" = Request for counters reading.

**CRC** corresponds to the sum (with inverted sign) of all the preceding bytes.

e.g., the START command "A" in ASCII code = 41; inverted it will be: FF + 1 - 41 = BF.

CHARACTER	ASCII	CONVERTED ASCII FOR CRC CALCULATION
"A"	41h	-
CRC	-	BFh
"B"	42h	-
CRC	-	BEh
"C"	43h	-
CRC	-	BDh
"D"	44h	-
CRC	-	BC h
"E"	45h	-
CRC	-	BBh
"F"	46h	-
CRC	-	BAh
"G"	47h	-
CRC	-	B9h
"H"	48h	-
"I"	49h	-
CRC	-	B7h
"J"	4Ah	-
CRC	-	B6h
"K"	4Bh	-
CRC	-	B5h
"ACK"	06h	-
CRC	-	FAh
"NACK"	15h	-
CRC	-	EBh

**Answer** = after a request from the host, the Turbo-V 301 controller will answer in one of the following ways:

- ACK
- NACK
- Message

When the Request is "A", "B", "C", "D", "F", the Turbo-V 301 controller will Answer the ACK or NACK.

When the Request is "E", the **Answer** will contain the complete set of the following parameters:

BYTES	MEANING	
1		
2÷5		Cycle Time
6÷9		Pump Life
10÷11		Pump Temperature
12		Current*
13		Voltage*
14÷17		Frequency
18÷19		Cycle #
20	R1 Status	
21	R2 Status	
22	CRC	

\*The values for current and voltage are given as numbers, scaled from 0 to 255, where 0 corresponds to 0 V and 255 to the full scale voltage (130 V) or current (2.5 A).

When the **Request** is "G", the **Answer** will contain a string of 11 characters with the following parameters:

BYTES	MEANING
1-2	Pump cycles number (integer coded in 2 bytes)
3	Speed threshold
4-7	Run up time in seconds (long coded in 4 bytes)
8	Deat time (0 = NO 1 = YES)
9	Reserved
10	Soft Start mode (0 = NO 1=YES)
11	CRC

When the configuration parameters have to be changed, send a **Request** string a string with 9 characters of the following type:

"H" + .... data .... + CRC

The following parameters can be changed:

BYTES	MEANING
1	Speed threshold
2-5	Run up time in seconds (long coded in 4 bytes)
6	Deat time (0 = NO 1 = YES)
7	Reserved
8	Soft Start mode (0 = YES 1 = NO)
9	CRC

When the **Request** is "I" (Status readings), the **Answer** will contain a string of 2 characters with the following parameters:

BYTES	MEANING
<div style="display: flex; justify-content: space-between;"> <span>MSB</span> <span>1</span> <span>LSB</span> </div> <div style="margin-top: 10px;"> <p>-- X X X X X X</p> <p>0 = STOP 1 = WAITING INTERLOCK 2 = STARTING 3 = NORMAL OPERATION 4, 5 = HIGH LOAD 6 = FAILURE 7 = APPROACHING LOW SPEED</p> <p>R2 status 0 = OFF    1 = ON R1 status 0 = OFF    1 = ON</p> </div>	
2	CRC

When the **Request** is "J" (Numerical readings), the **Answer** will contain a string of 5 characters with the following parameters:

BYTES	MEANING
1	Current (0-255 scaled)
2	Voltage (0-255 scaled)
3	Rotational speed KRPM
4	Pump temperature °C (0-254 temperature reading, 255 = fail)
5	CRC

When the **Request** is "K" (Counters readings), the **Answer** will contain a string of 11 characters with the following parameters:

BYTES	MEANING
1-4	Cycle time
5-8	Pump life
9-10	Cycle number
11	CRC

On request a sample program in QBasic language is available by Varian.

### Window Protocol

#### Description

#### Communication Format

- 8 data bit
- no parity
- 1 stop bit
- baud rate: 600/1200/2400/4800/9600 programmable

#### Communication Protocol

The communication protocol is a MASTER/SLAVE type where:

- Host = MASTER
- Controller = SLAVE

The communication is performed in the following way:

1. the host (MASTER) send a MESSAGE + CRC to the controller (SLAVE);
2. the controller answer with an ANSWER + CRC to the host.

The MESSAGE is a string with the following format:

<STX>+<ADDR>+<WIN>+<COM>+<DATA>+<ETX>+<CRC>

where:

#### NOTE

When a data is indicated between two quotes ('...') it means that the indicated data is the corresponding ASCII character.

- <STX> (Start of transmission) = 0x02
- <ADDR> (Unit address) = 0x80 (for RS 232)  
<ADDR> (Unit address) = 0x80 + device number (0 to 31) (for RS 485)
- <WIN> (Window) = a string of 3 numeric character indicating the window number (from '000' to '999'); for the meaning of each window see the relevant paragraph.
- <COM> (Command) = 0x30 to read the window, 0x31 to write into the window
- <DATA> = an alphanumeric ASCII string with the data to be written into the window. In case of a reading command this field is not present. The field length is variable according to the data type as per the following table:

DATA TYPE	FIELD LENGTH	VALID CHARACTERS
Logic (L)	1	'0' = OFF '1' = ON
Numeric (N)	6	'-', '.', '0' . . . '9' right justified with '0'
Alphanumeric (A)	10	from blank to '_' (ASCII)

- <ETX> (End of transmission) = 0x03
- <CRC> = XOR of all characters subsequent to <STX> and including the <ETX> terminator. The value is hexadecimal coded and indicated by two ASCII character.

The addressed SLAVE will respond with an ANSWER whose structure depends from the MESSAGE type. When the MESSAGE is a reading command, the SLAVE will respond transmitting a string with the same structure of the MESSAGE.

**NOTE**

Using the RS 485 interface, the message structure remains identical to the one used for the RS 232 interface, the only difference being that the value assigned to the ADDRESS <ADDR>

The controller can answers with the following response types:

<b>Response Type</b>	<b>Response Length</b>	<b>Response Value</b>	<b>Description</b>
Logic	1 byte	-	after a read instruction of a logic window
Numeric	6 bytes	-	after a read instruction of a numeric window
Alphanumeric	10 bytes	-	after a read instruction of an alphanumeric window
ACK	1 byte	(0x6)	the command execution has been successfully completed
NACK	1 byte	(0x15)	the command execution has been failed
Unknown Window	1 byte	(0x32)	the specified window in the command is not a valid window
Data Type Error	1 byte	(0x33)	the data type specified in the command (Logic, Numeric or Alphanumeric) is not accorded with the specified Window
Out of Range	1 byte	(0x34)	the value expressed during a write command is out of the range value of the specified window
Win Disabled	1 byte	(0x35)	the specified window is Read Only or temporarily disabled (for example you can't write the Soft Start when the Pump is running)



**Examples:**

**Command: START**

Source: PC

Destination: Controller

02	80	30	30	30	31	31	03	42	33
STX	ADDR	WINDOW			WR	ON	ETX	CRC	

Source: Controller

Destination: PC

02	80	06	03	38	35
STX	ADDR	ACK	ETX	CRC	

**Command: STOP**

Source: PC

Destination: Controller

02	80	30	30	30	31	30	03	42	32
STX	ADDR	WINDOW			WR	OFF	ETX	CRC	

Source: Controller

Destination: PC

02	80	06	03	38	35
STX	ADDR	ACK	ETX	CRC	

**Command: SOFT-START (ON)**

Source: PC

Destination: Controller

02	80	31	30	30	31	31	03	42	32
STX	ADDR	WINDOW			WR	ON	ETX	CRC	

Source: Controller

Destination: PC

02	80	06	03	38	35
STX	ADDR	ACK	ETX	CRC	

**Command: SOFT-START (OFF)**

Source: PC

Destination: Controller

02	80	31	30	30	31	30	03	42	33
STX	ADDR	WINDOW			WR	OFF	ETX	CRC	

Source: Controller

Destination: PC

02	80	06	03	38	35
STX	ADDR	ACK	ETX	CRC	

**Command: READ PUMP STATUS**

Source: PC

Destination: Controller (with address = 3)

02	83	32	30	35	30	03	38	37
STX	ADDR	WINDOW			RD	ETX	CRC	

Source: Controller (with address = 3 in stop status)

Destination: PC

02	83	32	30	35	30	30	30	30	30	03	38	37
STX	ADDR	WINDOW	DATA (STATUS)				ETX	CRC				

**Command: READ SERIAL TYPE**

Source: PC

Destination: Controller (with address = 3 in 485 mode)

02	83	35	30	34	30	03	38	31
STX	ADDR	WINDOW			RD	ETX	CRC	

Source: Controller

Destination: PC

02	83	35	30	34	30	31	03	42	30
STX	ADDR	WINDOW	RD	DATA	ETX	CRC			

**Window Meanings**

N.	Read/Write	Data Type	Description	Admitted Values
000	R/W	L	Start/Stop (in remote/ Front mode the window is a read only)	Start = 1 Stop = 0
001	R/W	L	Low Speed Activation	No = 0 Yes = 1 (default = 0)
008	R/W	L	Remote (default) or Serial configuration	Remote = 1 Serial = 0 (default = 1)
100	R/W	L	Soft Start (write only in Stop condition)	YES = 1 NO = 0
101	R/W	N	R1 Set Point type	0 = Frequency 1 = Power 2 = Time 3 = Normal 4 = Pressure (default = 3)
102	R/W	N	R1 Set Point valve (expressed in Hz, W or s)	(default = 900)
103	R/W	N	Set Point delay: time between the pump start and the set point check (seconds)	0 to 99999 (default = 0)
104	R/W	L	Set Point signal activation type: the signal can be "high level active" or "low level active"	0 = high level active 1 = low level active (default = 0)
105	R/W	N	Set point hysteresis (in % of value)	0 to 100 (default = 2)
106	R/W	L	Water cooling	0 = NO 1 = YES
107	R/W	L	Active Stop (write only in stop)	0 = NO 1 = YES
108	R/W	N	Baud rate	600 = 0 1200 = 1 2400 = 2 4800 = 3 9600 = 4 (default = 4)
109	W	L	Pump life/ cycle time/ cycle number reset	To reset write '1'
110	R/W	L	Interlock type (default = 1)	Impulse = 0 Continuous = 1

**TECHNICAL INFORMATION**

N.	Read/Write	Data Type	Description	Admitted Values
111	R/W	L	Analog output type: output voltage signal proportional to frequency or power	0 = frequency 1 = power (default = 1) 2 = Pump temperature 3 = Pressure
117	R/W	N	Low Speed frequency (Hz)	250 to "Maximum rotational frequency" (win 121) (default = 700)
120	R/W	N	Rotational frequency setting (Hz)	900 to "Maximum rotational frequency" (win 121) (default = 963)
122	R/W	L	Set vent valve on/off (on = closed)	On = 1 Off = 0 (default = 1)
123 124	Reserved to Varian service			
125	R/W	L	Set the vent valve operation	Automatic = 0 (see note 1.) On command = 1 (see note 2.)
126	R/W	N	Vent valve opening delay (expressed in 0.2 sec)	0 to 65535 (corresponding to 0 to 13107 sec)
130	Reserved to Varian service			
147	R/W	N	Vent open time See "vent connector" paragraph	0 = infinite 1 bit = 0.2 sec
155	R	N	Power limit applied Read the maximum allowable power	watt
157	R/W	N	Gas load type Select the gas load to the pump	Ø = N <sub>2</sub> 1 = Av
161	R/W	N	Pressure Reading Connection Factor See "GAUGE CONNECTOR" for more details	0 to 10 0 = 0 10 = 1 = N <sub>2</sub>
162	R/W	A	R1 Set Point Pressure Valve Valid if min. 101 = 4 Format X.X E. XX Where X = 0 to 9 s = + or -	

N.	Read/Write	Data Type	Description	Admitted Values
163	R/W	N	Pressure unit of measure	0 = mBar 1 = Pa 2 = Torr
167	R/W	A	Stop speed reading Activates / deactivates the pump speed reading after Stop command	0 = disable 1 = enable
171	R/W	N	R2 Set Point Type	0 = Freq 1 = Power 2 = Time 3 = Normal 4 = Pressure
172	R/W	N	R2 Set Point Value (Hz, W, s)	
173	R/W	N	R2 Set Point Mask (sec)	
174	R/W	L	R2 Set Point Segnal Activation Type	Ø = high level active 1 = low level active
175	R/W	N	R2 Set front Mysteresis (in % of R2 Valve)	
176	R	A	R2 Set Point Pressure Valve Valid in win 171 = 4 Format X.X E X.X Where: X= 0 to 9 s = + or -	
200	R	N	Pump current in mA dc	
201	R	N	Pump voltage in Vdc	
202	R	N	Pump power in W (pump current x pump voltage duty cycle)	
203	R	N	Driving frequency in Hz	
204	R	N	Pump temperature in °C	0 to 70

N.	Read/Write	Data Type	Description	Admitted Values
205	R	N	Pump status	Stop = 0 Waiting intlk = 1 Starting = 2 Auto-tuning = 3 Braking = 4 Normal = 5 Fail = 6
206	R	N	Error code	Bit description: see the following figure
211	R	N	Controller Heatsink Temperature (°C)	
216	R	N	Controller Air Temperature (°C).	
224	R	A	Pressure reading Format = X.X E XX	
226	R	N	Rotation Frequency (rpm)	
300	R	N	Cycle time in minutes (zeroed by the reset command)	0 to 999999
301	R	N	Cycle number (zeroed by the reset command)	0 to 9999
302	R	N	Pump life in hours (zeroed by the reset command)	0 to 999999
320 to 399	Reserved to Varian service			
400	R	A	CRC EPROM (QE)	QE8XXXX (where "XXXX" are variable)
402	R	A	CRC Param. (PA)	PA8XXXX (where "XXXX" are variable)
404	R	A	CRC Parameter structure	"XXXX"
500	Reserved to Varian service			
503	R/W	N	RS 485 address	0 to 31 (default = 0)
504	R/W	L	Serial type select	0 = RS 232 1 = RS 485 (default = 0)

**NOTES**

- Automatic means that when the controller stops, the vent valve is opened with a delay defined by window n. 126; when the controller starts, the vent valve is immediately closed.
- On command means that the vent valve is opened or closed by means of window n. 122.

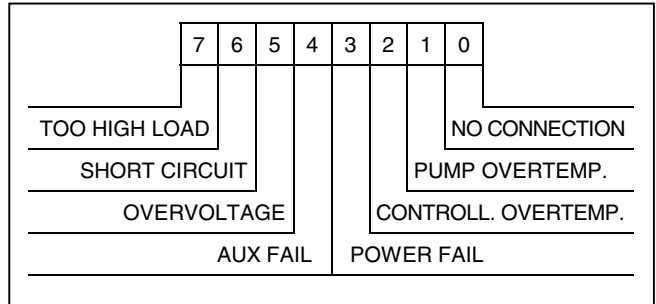

Window N. 206 Bit Description

**HOW TO USE BY FRONT PANEL**

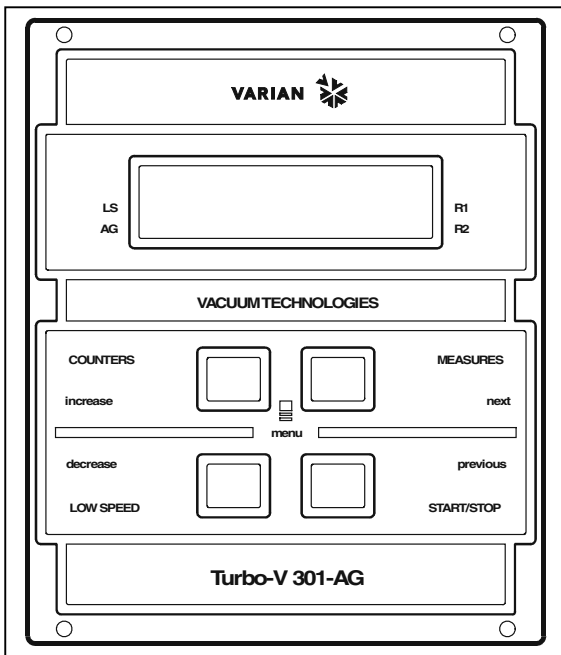

- **Start Stop and Reset Fail button**  
Press once for the START command and again for the STOP command.  
In the case of controller's failure, press once to reset the fail condition.

**NOTE**

The front panel START/STOP function is available only if the controller is set to "FRONT mode". If it is set to "REMOTE mode", when the key is pressed an error message is shown indicating "COMMAND LOCKED IN REMOTE", if it is set to "SERIAL" mode, the "COMMAND LOCKED IN SERIAL MODE" error message is displayed.

The "Reset Fail" function is always available regardless of controller mode.

- **Low Speed**  
Press once to activate the LOW SPEED command; press again to de-activate.

**NOTE**

The front panel LOW SPEED function is available only if the controller is set to "FRONT"; otherwise an error message is returned.

If it is set to "REMOTE" mode, the COMMAND LOCKED IN REMOTE error message is displayed while if it is in "SERIAL" mode the "COMMAND LOCKED IN SERIAL MODE" error message is returned.

- **Counters**

Pressing the first time on the display, the following information is displayed:

		C	Y	C	L	E		X	X	X	X			
		T	I	M	E			X	X	X	X	X	m	

Where

**CYCLE** XXXX Number of start/stop cycles

**TIME** XXXXXm Time of last cycle (minutes)

Pressing a second time, the following is displayed:

		P	U	M	P		L	I	F	E				
		X	X	X	X	X	X	X	X	h				

**PUMP LIFE**

**XXXXXX** total operating time (hours) of the pump

Pressing a third time, the following message is displayed:

	M	N	:		X	X	X	X	X	X	X	X	X	X
	S	N	:		Y	Y	Y	Y	Y	Y	Y	Y	Y	Y

**MN** Model Number of the controller

**SN** Serial Number

On pressing the key again, the main screen page is redisplayed.

- **Measures**

Pressing once, the following is obtained:

P	=	X	X	X	W				X	X	X	X	H	z
					T	=	X	X	°	C				

Where:

**P= XXX W** is the current power supplied to the pump

**T=XX °C** is the current temperature of the pump

**XXXX Hz** is the current frequency of rotation of the pump. This value is set by default to 963 Hz but can be modified by the user according to needs, proceeding as described in the "PROGRAMMING" paragraph. The unit of measurement (HZ / Krpm, default = Hz) is selected by the user from the INPUT/OUTPUT->SPED menu.

If the SOFT-START function (PUMP SETTING menu → SOFTSTART is active and the pump is ramping, indication of the speed of rotation is replaced with a bar-graph that indicates the soft-start step in course and the total number of steps to be performed.

On completion of the soft-start ramp, the bar-graph is replaced with indication of the frequency of rotation of the pump

Pressing twice, the following is obtained:

N	O	R	M	A	L				X	X	X	X	H	z			
					I	=	X	.	X	X	A	V	=	X	X	X	V

Where:

**NORMAL:** indicates the operating regime of the pump

**XXXXHz:** see description "Pressing once" **Measures** key

**I=X.XXA:** indicates the current absorbed by the pump

**V= XXX V:** indicates the pump driving voltage

Pressing 3 times, the following is obtained:

P	=	X	X	X	W				X	X	X	X	H	z		
					X	.	X	X	E	-	Y	Y	m	B	a	r

Where:

**P= XXXW:** indicates the current power supplied to the pump

**XXXHz:** see description "Pressing once" **Measures** key

**x.xxE-yy mbar:** indicates the pressure currently measured by the gauge.

Other possible indications:

P	=	X	X	X	W				X	X	X	X	H	z	
					P	R	A	U	G	E	E	R	R	O	R

Where:

**GAUGE\_ERROR:** gauge not connected or broken

P	=	X	X	X	W				X	X	X	X	H	z			
					P	R	E	S	S	U	R	E	U	N	D	E	R

Where:

**PRESS UNDER:** indicates that the pressure read is below the minimum measurement threshold set (5 E-9 mBar)

P	=	X	X	X	W				X	X	X	X	H	z		
					P	R	E	S	S	U	R	E	O	V	E	R

Where:

**PRESS OVER:** indicates that the pressure measured is above the maximum measurement threshold set (1000 mBar)

The unit of measurement of the pressure can be selected (GAUGE menu→Unit) from "mBar", "Pa", "torr"

Pressing 4 times returns to the following screen page:

N	O	R	M	A	L					X	X	X	X	H	z
	X	X	X	X	X	X	X	X	X	X	X	X	X	X	

Where:

**NORMAL:** indicates the operating regime of the pump

**XXXHz:** see description "Pressing once" **Measures** key

The operating mode of the controller is shown at the bottom in the center. This may be:

**FRONT:** front mode (the controller accepts START/STOP and LOW SPEED commands from the front panel)

**REMOTE:** remote mode (the controller accepts START/STOP and LOW SPEED commands via the rear connector)

**RS232:** the controller accepts commands from the serial port according to the RS232 standard.

**RS485 [XX]:** the controller accepts commands from the serial port in RS485 mode with address XX (XX from 0 to 31)

**PROFIBUS [YYY]:** the controller accepts commands from the PROFIBUS port with address YYY

Black rectangles as shown below may be displayed at any time in the first and last box of the bottom line of the display (opposite the LS / AG / R1 / R2 captions). The meaning of these rectangles is as follows:

- LS → the controller is at LOW SPEED
- AG → the Gauge is connected to the controller
- R1 → relay (set point ) R1 is active
- R2 → relay (set point ) R2 is active

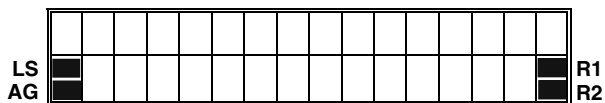

**USE**

**General**

Make all vacuum manifold and electrical connections and refer to Turbo-V pump instruction manual before to operating the Turbo-V controller.



**WARNING!**

To avoid injury to personnel and damage to the equipment, if the pump is laying on a table make sure it is steady. Never operate the Turbo-V pump if the pump inlet is not connected to the system or blanked off.

**NOTE**

*The input signal P1 connector should be left in position including the shipping links if no external connections are made. The forepump and the Turbo-V pump can be switched on at the same time.*

**Startup**

- Plug the controller power cable into a suitable power source.
- The display lights up for approx. 2 seconds and shows:

			A	U	T	O	T	E	S	T	-	-	-
						O	K						

- After 2 seconds, the display shows the following screen page:

S	T	O	P					.	.	.	.	H	Z
				F	R	O	N	T					

**NOTE**

If the pump is not connected, the display will be as follows:

C	H	E	C	K		C	O	N	N	E	C	T	I	O	N
				T	O			P	U	M	P				

- Pressing the START button, the pump is started and the display shows the following screen page.

S	T	A	R	T	I	N	G			X	X	X	X	H	Z
						F	R	O	N	T					

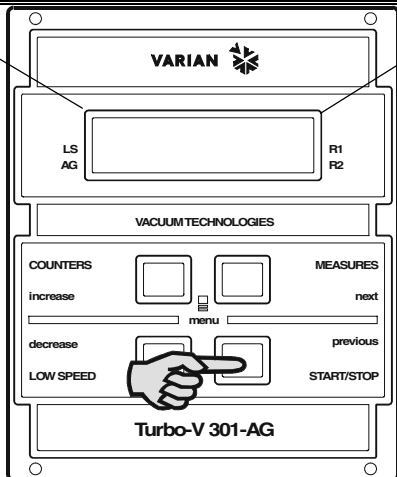

This screen page will be visible throughout the acceleration phase the pump. The increasing value of the rotation frequency will be displayed in the boxes marked X; the user may decide to express this value in Hz (default) or in KRMP.

Once operating speed has been reached, the following screen page is displayed:

N	O	R	M	A	L					9	6	3	H	Z
				F	R	O	N	T						

If the LOW SPEED key is pressed, the above screen page changes to:

B	R	A	K	I	N	G				X	X	X	X	H	Z
				F	R	O	N	T							

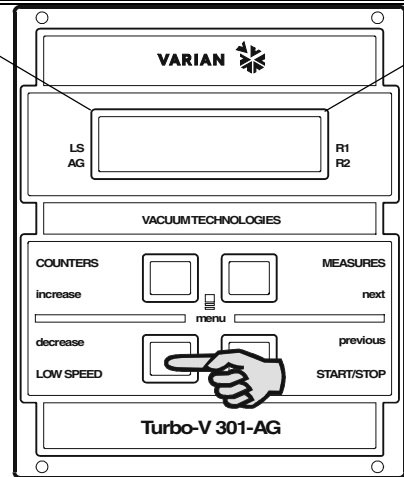

The following screen page is displayed on reaching the pre-established speed:

N	O	R	M	A	L					9	0	0	H	Z
				F	R	O	N	T						

The rotation value set in both NORMAL and LOW SPEED mode can be modified by the user as described in the Programming section of this manual.

- Press the MEASURES push button: the display shows:

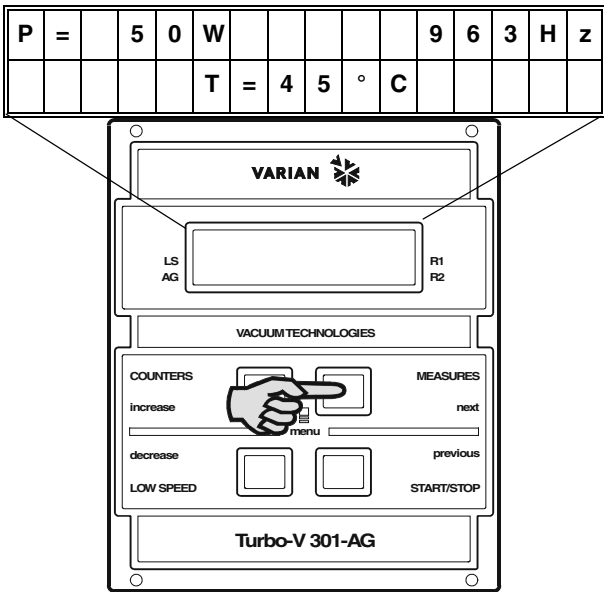

where

**P** = is the DC power drawn by the pump (range 0 to 999 Watt)

**Hz** = is the rotational speed of the pump as a function of the controller output frequency

**°C** = is the temperature of the outer ring of the upper bearing (range 00 to 99 °C)

- Pressing MEASURES key twice, the following screen page is displayed:

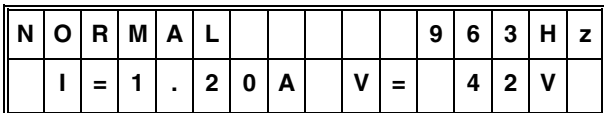

Where:

**I** is the current supplied by the controller to the pump at that precise moment.

**V** is the voltage at which the controller is powering the pump at that moment

- Pressing the MEASURES key three times, with the GAUGE connected and functioning, the following screen page is displayed:

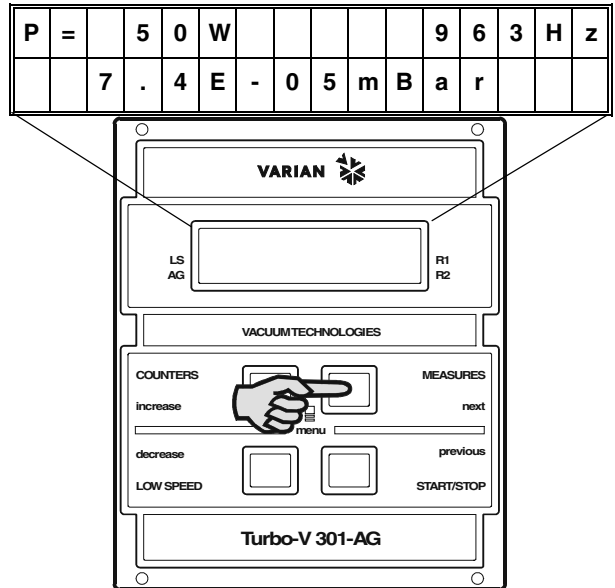

Where:

**mBar** shows the pressure value measured

The following messages may be displayed instead of the pressure:

**GAUGE ERROR:** indicates that the GAUGE is not present or is not working

**PRESSURE UNDER:** indicates that a pressure below the minimum threshold set has been measured ( $5 \times 10^{-9}$  mBar)

**PRESSURE OVER:** indicates that a pressure exceeding the maximum threshold set has been measured ( $1 \times 10^3$  mBar)



Pressing the COUNTERS key, the following is obtained:

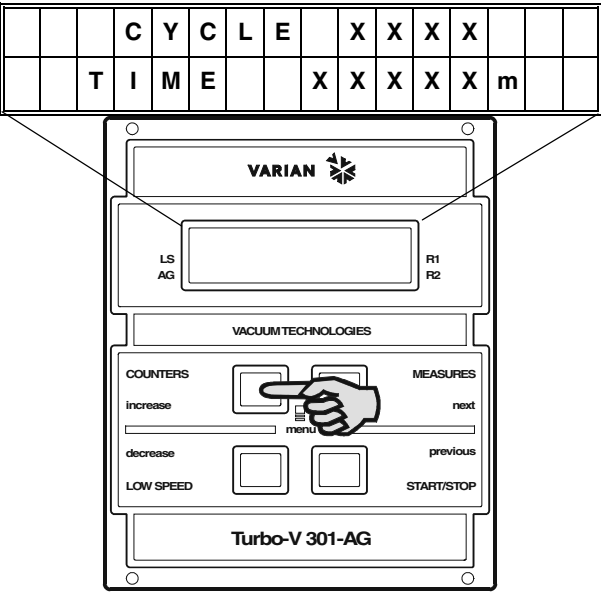

Where

**CYCLE** XXXX Number of start/stop cycles  
**TIME** XXXXXm Time of last cycle (minutes)

Pressing again:

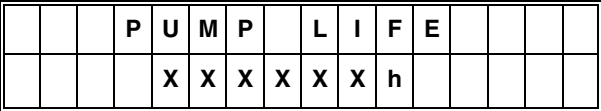

Where:

**PUMP LIFE**  
**XXXXXX** total operating time (hours) of the pump

**Programming**

**Configuration menu**

To access the configuration menu, press the COUNTERS + MEASURES buttons at the same time for at least 2 sec.

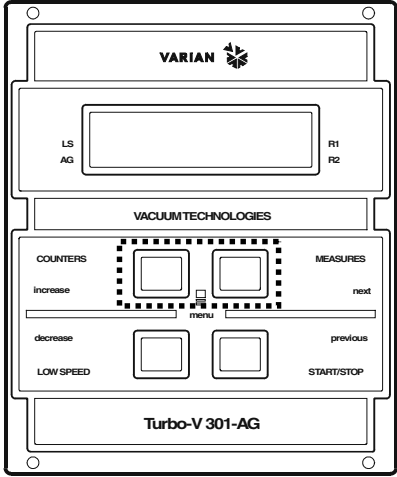

In programming mode, the meaning of the 4 buttons changes as follows:

- **COUNTERS/LOW SPEED** speed become **“INCREASE and DECREASE”** and make it possible to select the next or previous value of a parameter (in the case of compulsory parameters) or to increase/decrease the individual digit of a parameter (in the case of numeric parameters)
- The **“MEASURES and START/STOP”** buttons become **“NEXT and PREVIOUS”** and make it possible to select the next parameter (or next digit of a numeric parameter) or previous parameter.

Switching from one parameter to the next (using the **“NEXT”** key) indicates confirmation of any changes made to the specific parameter. If the changes cannot be accepted by the controller, the **“Data out of limits”** error message is displayed, the changes are cancelled and the value of the parameter prior to the modification is reposed.

Switching from a parameter to the previous parameter (using the “PREVIOUS” key) indicates the intention to abort any changes made to the specific parameter. Abort is indicated by the caption “**Changes aborted**” that is displayed for approx. 1 second before moving to the previous parameter.

The configuration environment has a tree-like structure and permits “circular” navigation; on reaching the end of a branch, the user is returned automatically to the start of this. Navigation can proceed in a forwards (NEXT button) or backwards (PREVIOUS button) direction

It is possible to enter a sub-branch by pressing the “INCREASE” button..

If no buttons are pressed for more than 1 minute, the controller automatically quits the programming environment canceling any modifications made to the current parameter.

The figure below shows the first level of the configuration menu and the links to the respective second level menus (indicated below).

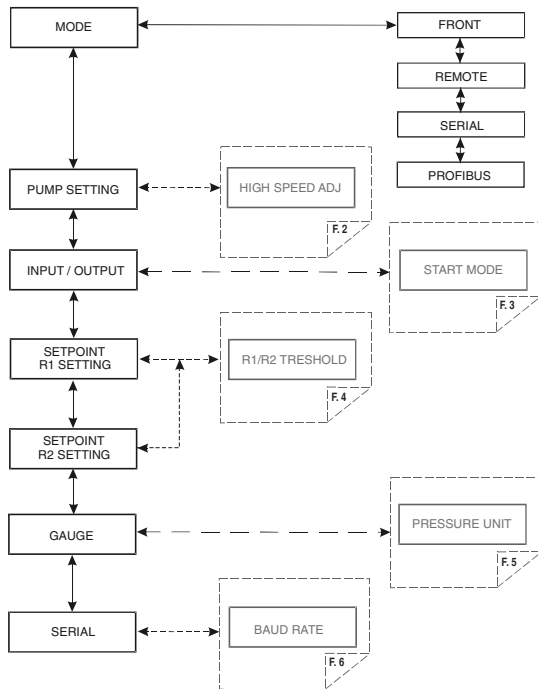

Flow 1/6

**Mode menu**

- **MODE:** permits selection (see Flow 1/6) of the operating mode of the controller from those indicated below:
  - FRONT: accepts commands from the front panel
  - REMOTE: accepts commands from the remote input connector
  - SERIAL: accepts commands from the serial interface (or Profibus interface if present)
  - PROFIBUS: this operating mode is present only if the Profibus interface is installed on the controller

**PUMP SETTING menu**

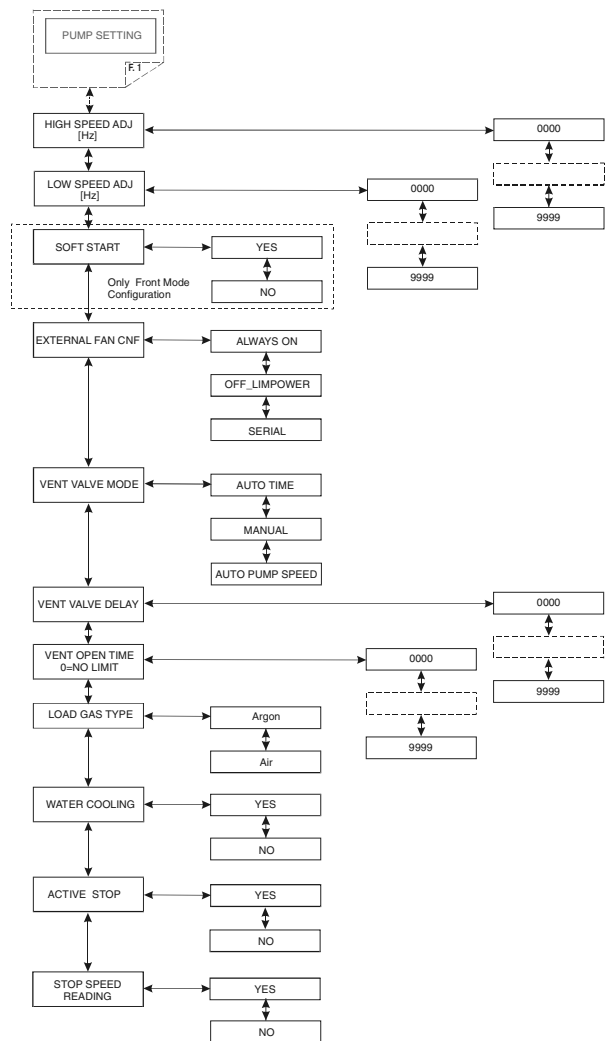

Flow 2/6

This menu contains all the parameters that have a direct effect on driving of the pump.

- **HIGH SPEED:** Sets (in Hz) the speed of rotation of the pump when the low-speed function is not active.
- **LOW SPEED:** Sets (in Hz) the speed of rotation of the pump when the low-speed function is active.
- **SOFT START:** enables (YES) or disables (NO) the soft start function. This parameter is visible only if the controller is configured in FRONT mode.
- **EXTERNAL FAN CNF:** Makes it possible to select driving mode of the external cooling fan. Possible options:
  - ALWAYS ON: the cooling fan is always ON
  - OFF\_LIMPOWER: 10 seconds after the pump has reached NORMAL status, the fan is switched off and the driving power of the pump is reduced to 50 W
  - SERIAL: the cooling fan is controlled directly via the serial port.

- **VENT VALVE MODE:** makes it possible to select driving of the vent valve
  - AUTO TIME: the valve is controlled by the controller
  - MANUAL: the valve is controlled by the serial port.
  - AUTO PUMP SPEED: the valve is controlled by the controller its king into account the pump's deceleration.
- **VENT VALVE DELAY:** Sets the delay, expressed in seconds, between stopping of the pump and opening of the vent valve.
- **VENT VALVE OPEN TIME:** sets the time, expressed in seconds, of opening of the vent valve. Enter 0 if the valve is to be kept open indefinitely (until the next start).
- **LOAD GAS TYPE:** selects the type of gas used in the process. Therefore, the controller limits the power supplied to the pump according to the setting of this parameter.
- **WATER COOLING:** indicates whether the pump is cooled with water or not. The controller limits the power supplied to the pump according to this setting.
- **ACTIVE STOP:** enables (YES) or disables (NO) active braking.
- **STOP SPEED READING:** enables (YES) or disables (NO) the pump rotational frequency reading function also during the slowing phase that follows a stop command

- **START MODE:** Permits selection of one of the three types of functioning of the START/STOP and INTERLOCK inputs:
  - START/INTERLOCK: The pump is started if the START/STOP input is activated and is stopped if the START/STOP input is deactivated. The interlock input must be constantly active (INTERLOCK TYPE parameter = continuous) or may be active only at the time of starting (INTERLOCK TYPE parameter = impulsive)
  - START/STOP LEVEL The START/STOP input acts as only START command (active on the level) The INTERLOCK input acts as STOP command (active on the level)  
In the case of concurrent activation of the two inputs, the STOP command takes priority
  - START/STOP EDGE The START/STOP input acts as START command (active on the edge) The INTERLOCK input acts as STOP command (active on the edge).
- **INTERLOCK TYPE:** This parameter is displayed only when the previous parameter (START MODE) is equal to START/INTERLOCK and permits selection of one of the following two operating modes of the INTERLOCK input:
  - CONTINUOUS: the INTERLOCK input must be active continuously so that the pump can be driven by the controller. If, with the controller in start, the input INTERLOCK is deactivated, the controller switches to WAITING INTERLOCK status and interrupts driving of the pump
  - IMPULSIVE: it is sufficient for the input to be active when the START command is sent to the pump. Subsequently, the input can also be de-activated. If the interlock is not active when the pump is started, the controller switches too WAITING INTERLOCK status.

**INPUT/OUTPUT menu**

This menu contains parameters that determine the operating mode of the inputs and outputs of the controller.

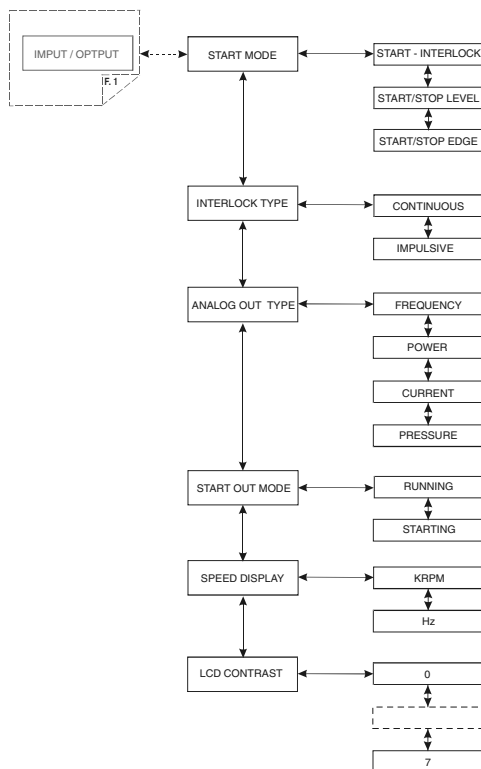

Flow 3/6

- **ANALOG OUT TYPE:** permits selection of the type of signal to be sent to the programmable analogue output. One of the following signals can be selected:
  - FREQUENCY: the drive frequency of the pump is shown
  - POWER: the power supplied to the pump is shown
  - TEMPERATURE: the temperature of the pump is shown
  - PRESSURE: the pressure read by the gauge is shown.
- **START OUT MODE:** Selects the operating mode of the START output. Possible options:
  - RUNNING: the output is active when the pump is driven
  - STARTING: the output is active only during acceleration ramp-up.
- **SPEED OUT MODE (KRPM/Hz):** permits selection of the unit of measurement of the speed of rotation shown on the display of the controller. This setting acts only on the measurement shown on the display. Possible options:
  - KRPM
  - Hz

- **LCD CONTRAST**

**SETPOINT R1 and SETPOINT R2 submenus**

This submenu contains the settings relating to the output with relay R1 (R2).

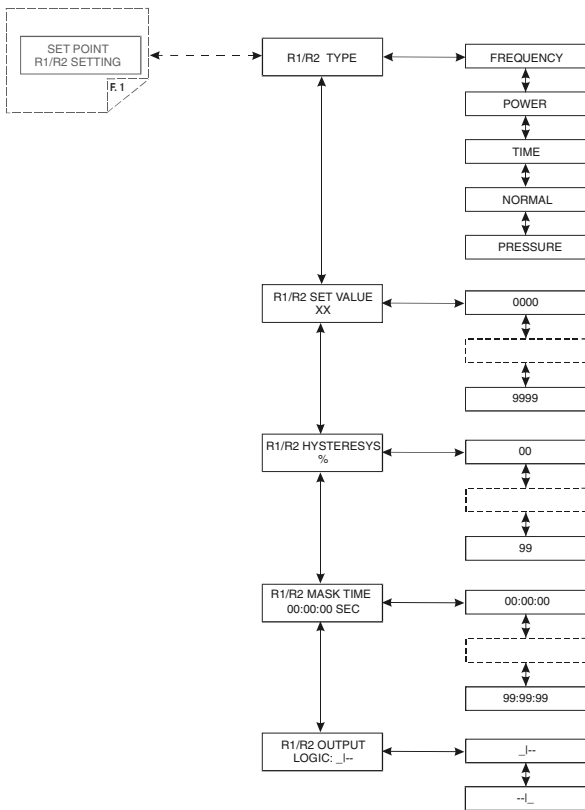

Flow 4/6

- **R1 (R2) TYPE:** selects the type of reference measurement to drive the relay. Possible types:
  - Frequency: driving frequency of the pump
  - Power: power supplied to the pump
  - Time: time from start
  - Normal: achievement of normal condition
  - Pressure: pressure read by the gauge, if present
- **R1 (R2) SET VALUE:** Sets the reference value at which the relay R1 (R2) is activated. This parameter is not available if TIME or NORMAL (previous parameter) is selected as SETPOINT TYPE.
- **R1 (R2) HISTERESYS:** Sets, in percentage, the hysteresis of the relay
- **R1 (R2) MASK TIME:** sets the masked time (in hh:mm:ss), measured from start, within which the SETPOINT R1 (R2) is not driven even if the threshold value has been reached. This parameter is not available if SETPOINT TYPE is set to NORMAL

- **R1 (R2) OUTPUT LOGIC:** Selects the control logic of the SETPOINT output.

\_|-- positive logic (the relay is energized when the measurement exceeds the reference)

--|\_ negative logic (the relay is energized when the measurement is below the reference)

This parameter is not available if SETPOINT TYPE is set to TIME or NORMAL.

**GAUGE menu**

This menu contains the parameters relating to functioning of the active gauge.

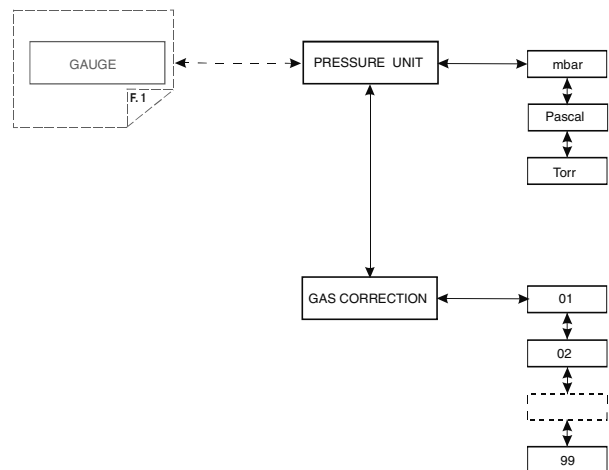

Flow 5/6

- **PRESSURE UNIT:** selects the unit of measurement of the pressure used to show this on the display, for display on the serial line and for setting of the setpoint and autoproessure thresholds. Possible options:
  - mbar
  - Pascal
  - Torr
- **GAS CORRECTION:** sets the conversion factor of the pressure measurement in the case in which the process gas is not nitrogen. The pressure indicated by the instrument is equal to:
 
$$P \text{ indicated} = P \text{ measured} \times \text{Gas correction} / 10$$

**SERIAL menu**

This menu contains the settings for management of the RS232/485 serial line.

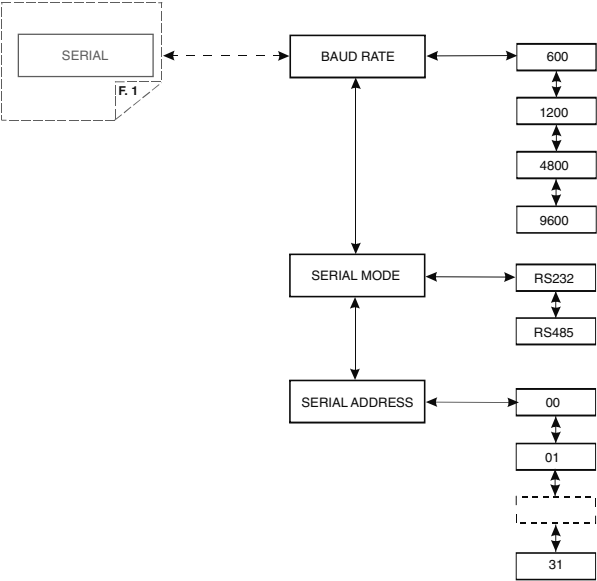

Flow 6/6

- **BAUD RATE:** permits selection of the communication speed selecting this from 600, 1200, 4800, 9600 baud
- **SERIAL MODE:** permits setting of the type of interface to RS232 (point to point) or RS485 (multidrop)
- **SERIAL ADDRESS:** sets the address of the node in the case of the RS485 interface. This parameter is not visible if the RS232 is selected.

**HOW TO USE BY REMOTE I/O**

1. Power ON the controller
2. Press the "COUNTERS" and "MEASURES" button together.
3. Select MODE = REMOTE from the "INPUT/OUTPUT" menu
4. Exit from configuration menu
5. Connection example:

**HOW TO USE IN SERIAL MODE**

1. Power on the controller
2. Connect the serial cable
3. Select by front panel if you want to work in 232 or 485, and if necessary, the serial address.
4. Select SERIAL from the INPUT/OUTPUT menu
5. Open the T+ software (see orderable parts table)
6. Ready to operate by SERIAL connections.

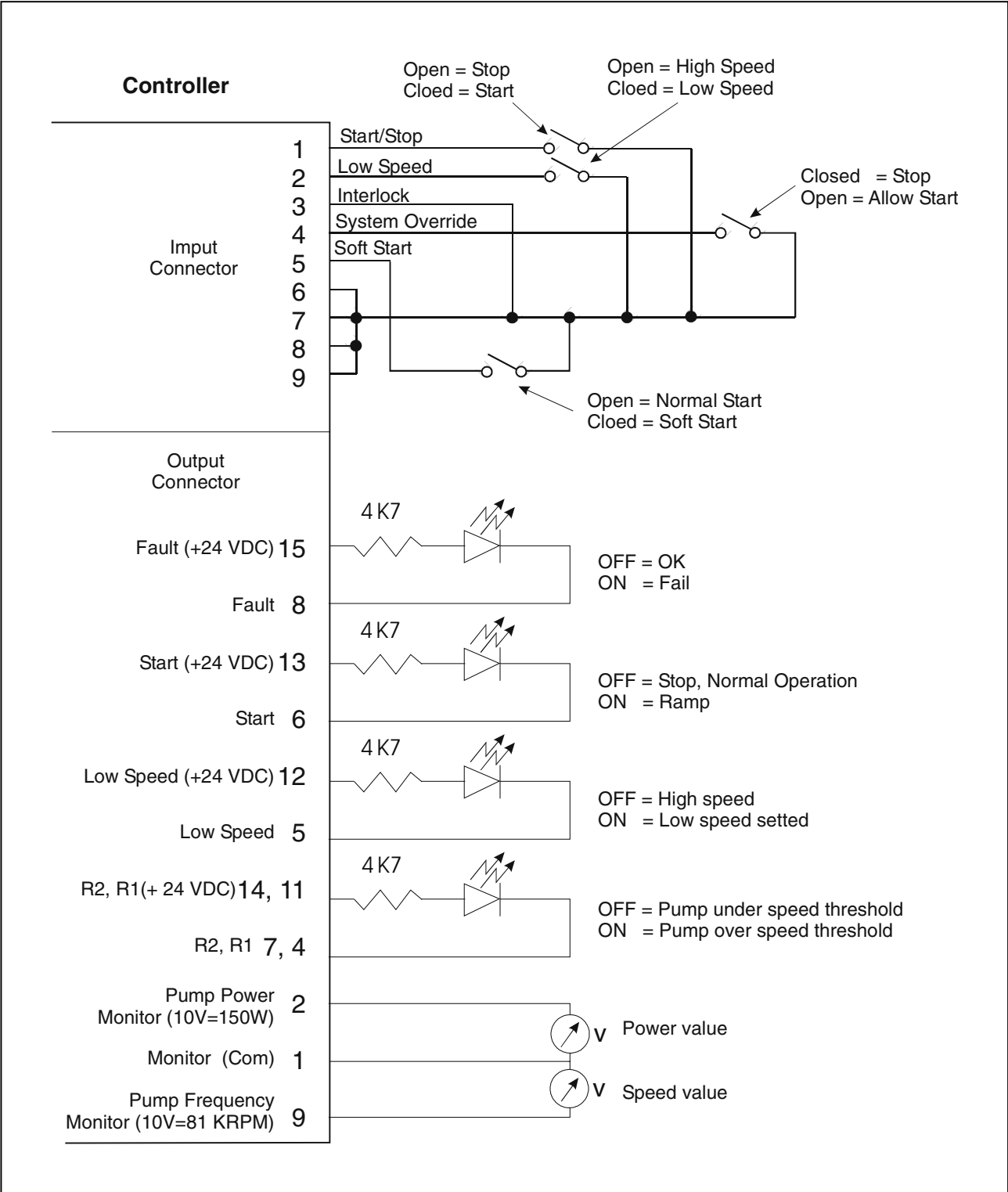

**PROFIBUS OPTION**

**General**

The ProfiBus option allow to communicate with the controller as ProfiBus DP slave device.

The option works as a bi-directional bridge between the ProfiBus network and the Varian turbo controller internal link. The interface provides input data (measures) and output data (commands) to the controller, and in addition provides standard and user related diagnostics, in order to allow the user to manage the exceptions.

**Installation**

This option is factory installed.

The ProfiBus connector pin-out is reported in the following figure. Please in order to obtain best performance use ProfiBus certified cables.

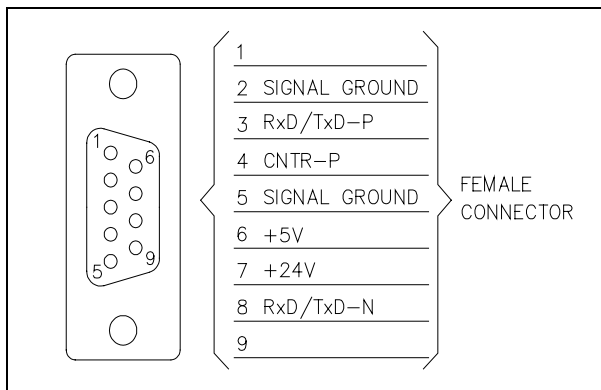

*ProfiBus connector*

**Configuration**

Before power-on the controller set the ProfiBus address by the 2 rotary switches.

Up to 126 different addresses (from 0 to 125) can be selected. The address value sets by the 2 switches is expressed in hexadecimal notation, so value from 00 to 7D are permitted; this setting is read by the interface during the power-on phase, so any change of the switch position after the power-on is ignored.

**Software operation and state machine**

From the software point of view, the interface can be seen as two devices (one for ProfiBus and the other for the internal link) linked together.

Each device has its own state machine to manage the device operation.

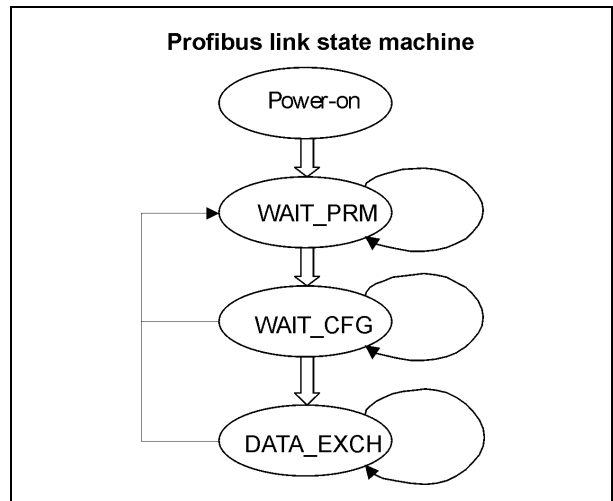

PROFIBUS STATE MACHINE	
Status	Meaning
POWER_ON	Interface set-up
WAIT_PRM	Wait for parameterisation from the master
WAIT_CFG	Wait for configuration from the master
DATA_EX	Regular data exchange

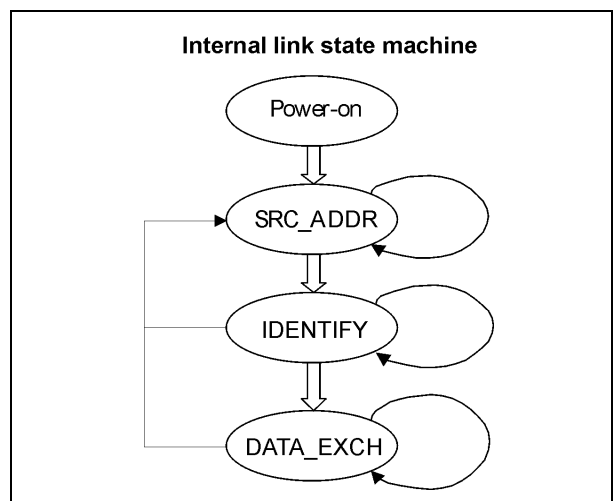

<b>INTERNAL LINK STATE MACHINE</b>	
<b>Status</b>	<b>Meaning</b>
POWER_ON	Interface set-up
SRC_ADDR	Search for the controller serial address
IDENTIFY	Identify controller model and protocol
DATA_EX	Regular data exchange

The two machines continuously share I/O data with the relative bus, and interact each other only in following conditions:

- ProfiBus Data Exchange is suspended (static diagnosis activated) if the internal serial link is not established
- Internal serial link Data Exchange is suspended (only for output data) if the ProfiBus State machine is not in Data Exchange mode

As a general rule, unrecoverable communication errors make each machine to jump to the state immediately following the power-on state (WAIT\_PRM or SRC\_ADDR)

***Message mapping***

The communication is based on the continuous data exchange capability of the ProfiBus standard, where the master sends continuously the entire slave configuration and reads back the entire slave status. For this purpose one Input (from slave to master) and one Output (from master to slave) buffers are provided. All the needed parameters are mapped inside each buffer.

The following tables summarise the ProfiBus parameter access, related to the corresponding windows serial protocol (for this protocol please refer to the serial interface paragraph).

The interface doesn't any scaling operation on the read/written parameters. It acts only as a gateway between the ProfiBus network and the pump's controller serial interface. As a consequence of this, the scale and the meaning of some parameters depends directly to the specific model of Turbo Pump controller connected to the interface.



## Parameter Buffer

Offset Byte	Size Byte	Unit Res	Range	Description	WIN Serial
0	1	-	0-99	Gauge gas load type The value is divided by 10 (entering 12 the controller will apply 1.2) <i>Enter here the correction factor for gas (necessary only if gauge is connected).</i>	
1	2	mA/Hz/sec	0-10000	Setpoint 1 value <i>Enter here the threshold value for the R1 output, valid only if B<sub>0</sub>-B<sub>2</sub> of Parameter Buffer Offset-20 is equal to 0,1,2 or 3.</i>	102
3	2	Sec	0-30000	Setpoint 1 Mask Time <i>Set here the time, measured from the start pump event, while the R1 output is masked (not activated)</i>	103
5	2	mA/Hz/sec	0-10000	Setpoint 2 value <i>Enter here the threshold value for the R2 output, valid only if B<sub>3</sub>-B<sub>5</sub> of Parameter Buffer Offset-20 is equal to 0,1,2 or 3.</i>	172
7	2	Sec	0-30000	Setpoint 2 Mask Time <i>Set here the time, measured from the start pump event, while the R2 output is masked (not activated)</i>	173
9	2	0.2sec/bit	0-30000	Vent Valve Opening Delay <i>Set the delay time between the stop command and vent opening. Valid only in "purge/vent auto mode" (Parameter Buffer, Offset 19, B<sub>0</sub> = 0). 0 = infinite (the valve will never open).</i>	126
11	2	0.2sec/bit	0-30000	Vent Valve Open Time <i>Set how long the vent will remain open, then both purge and vent will be closed. Valid only in "purge/vent auto mode" (Parameter Buffer, Offset 19, B<sub>0</sub> = 0). 0 = infinite (the valve remain open till next start command).</i>	147
13	1	%	1-99	Setpoint 1 Hysteresis <i>Set the Setpoint1 hysteresis around the nominal value</i>	105
14	1	%	1-99	Setpoint 2 Hysteresis <i>Set the Setpoint2 hysteresis around the nominal value</i>	175
15	1	mBar/Torr/ Pa	0-99	Setpoint 1 Pressure Value Mantissa <i>Set the mantissa of the exponential value of the R1 setpoint (format X.XE-XX) when it is used for pressure monitoring (Parameter Buffer, Offset 20, B<sub>0-2</sub> = 4). The value set here is divided by 10, that means 11 = 1.1</i>	162
16	1		-10 - +10	Setpoint 1 Pressure Value Exponent <i>Set the exponent of the exponential value of the R1 setpoint (format X.XE-XX) when it is used for pressure monitoring (Parameter Buffer, Offset 20, B<sub>0-2</sub> = 4).</i>	162
17	1	mBar/Torr/ Pa	0-99	Setpoint 2 Pressure Value Mantissa <i>Set the mantissa of the exponential value of the R2 setpoint (format X.XE-XX) when it is used for pressure monitoring (Parameter Buffer, Offset 20, B<sub>3-5</sub> = 4). The value set here is divided by 10, that means 11 = 1.1</i>	176

Offset Byte	Size Byte	Unit Res	Range	Description	WIN Serial
18	1		-10 - +10	Setpoint 2 Pressure Value Exponent <i>Set the exponent of the exponential value of the R2 setpoint (format X.XE-XX) when it is used for pressure monitoring (Parameter Buffer, Offset 20, B<sub>3-5</sub> = 4).</i>	176
19	1			B <sub>0</sub> = Stop Speed Reading <i>This function measures the pump speed after a stop command. 0 = Off 1 = On</i>	167
				B <sub>1</sub> = Active Stop <i>This function brakes the pump after a stop command, by using the motor as a generator. 0 = Off 1 = On</i>	107
				B <sub>2</sub> - Reserved	
				B <sub>3-4</sub> = Start/Stop/Interlock Mode <i>Change the logic of Start/Stop and Interlock inputs. Ask to Varian personnel for this option</i>	151
20	1			B <sub>0</sub> = Vent & Purge Auto/Man <i>0 = Auto (the controller drives purge and vent valves automatically) 1 = Manual (the user can command the valves by serial line or profibus)</i>	125
				B <sub>1</sub> = Gas Load Type <i>Select here the gas load 0 = Ar 1 = N<sub>2</sub></i>	157
				B <sub>2</sub> – Interlock Type <i>0 = continuous (the interlock must be always present to run the pump) 1 = at start (the interlock must be present only at start command)</i>	110
				B <sub>3</sub> = Setpoint R1 Logic <i>0 = active close (NO) 1 = active open (NC)</i>	104
				B <sub>4</sub> = Setpoint R2 Logic <i>0 = active close (NO) 1 = active open (NC)</i>	174
				B <sub>5-6</sub> = Pressure Unit <i>0 = mbar 1 = Pascal 2 = Torr</i>	163
				B <sub>7</sub> = Reserved	

Offset Byte	Size Byte	Unit Res	Range	Description	WIN Serial
21	1			B <sub>0-2</sub> = Setpoint R1 Type <i>0 = frequency</i> <i>1 = current</i> <i>2 = time</i> <i>3= normal operation</i> <i>4= pressure</i>	101
				B <sub>3-5</sub> = Setpoint R2 Type <i>0 = frequency</i> <i>1 = current</i> <i>2 = time</i> <i>3= normal operation</i> <i>4= pressure</i>	171
				B <sub>6-7</sub> =Analog Output 1 Type <i>0 = frequency</i> <i>1 = power</i> <i>2 = temperature</i> <i>3= pressure</i>	111

## Output Buffer

Offset Byte	Size Byte	Unit Res	Range	Description	WIN Serial
0	1			B <sub>7</sub> = Start/Stop <i>0 = Stop, 1 = Start</i>	000
				B <sub>6</sub> = Low Speed <i>This bit set the pump target speed to "low speed value" (Output Buffer, Offset 3), otherwise the target speed is set to "high speed value" (Output Buffer, Offset 1). 0 =Off, 1 =On</i>	001
				B <sub>5</sub> – Soft Start <i>This bit activates the soft start function which run-up the pump smoothly. Please activate this function only if the pump has been stopped for at least 3 months. 0 = On, 1= Off</i>	100
				B <sub>4</sub> = Vent Valve Command <i>0 = Close 1 = Open Valid only if in Par Buff, Offset-19, B<sub>0</sub>=1</i>	122
				B <sub>3</sub> = Purge Valve Command <i>0 = Close 1 = Open Valid only if Par Buff, Offset-19, B<sub>0</sub>=1</i>	145
				B <sub>2</sub> – Not used	
				B <sub>0-1</sub> = Operating Mode <i>These bits define from which source the controller has to get commands (readings are always available). In order to operate the controller by Profibus these bits must be set to 3. 0 = Remote I/O 1 = Serial 2 = Front panel 3 = Profibus</i>	008
1	2	Hz	1100 - 1350	High Speed Value <i>Set the high rotational speed value</i>	120
3	2	Hz	1100 - 1350	Low Speed Value <i>Set the low rotational speed value</i>	117

## Input Buffer

Offset Byte	Size Byte	Unit Res	Range	Description	WIN Serial
0	1	V	0-100	Voltage <i>Voltage provided to the motor</i>	201
1	1	°C	0-100	Pump Bearing Temperature <i>Read the pump upper bearing temperature If &gt; 60°C the controller goes into fail status and the pump is stopped</i>	204
2	1	°C	0-100	Controller Power Supply Temperature <i>Read the controller power section temperature if &gt; 75°C the controller goes in fail status "controller over-temperature"</i>	216
3	1	°C	0-100	Controller CPU Section Temperature <i>Read the controller CPU section temperature if &gt; 80°C the controller goes in fail "controller over-temperature"</i>	211
4	1	-	0-6	B <sub>0-3</sub> – Status <i>0 = Stop 1= Waiting for interlock (interlock connections on remote I/O connector missing) 2 = Ramp (the pump is increasing the speed) 3 = Auto tuning (the speed has been reduced because the gas load is higher than the Power Limit Applied) 4 = Braking (the pump is reducing the speed using the motor) 5 = Normal operation (the pump is at target speed) 6 = Fail (see error code byte Input Buffer Byte-27)</i>	205
5	1	-	-	Error Code (bit field) B <sub>7</sub> – Too High Load <i>(the gas load is too high for the pump)</i> B <sub>6</sub> – Short Circuit <i>(a short circuit happened between the two of the three motor phases)</i> B <sub>5</sub> – Over Voltage <i>(too high bus voltage during braking)</i> B <sub>4</sub> – Verify Line Select <i>Not used</i> B <sub>3</sub> – Power Fail <i>(internal circuitry failure)</i> B <sub>2</sub> – Controller Over-Temperature <i>( "Controller Power Section Temperature" or "Controller CPU Section Temperature" are over the limit)</i> B <sub>1</sub> - Pump Over-Temperature <i>("Pump Bearing Temperature" or "Pump Body Temperature" are over the limit)</i> B <sub>0</sub> – Check Connection To Pump <i>(the connection between controller and pump missing)</i>	206

Offset Byte	Size Byte	Unit Res	Range	Description	WIN Serial
6	1	-	-	B <sub>0</sub> – Set Point R1 Status <i>0 = open</i> <i>1 = closed</i>	221
				B <sub>1</sub> – Set Point R2 Status <i>0 = open</i> <i>1 = closed</i>	225
				B <sub>2</sub> – Vent Valve Status <i>0 = closed</i> <i>1 = open</i>	122
				B <sub>3</sub> – Purge Valve Status <i>0 = close</i> <i>1 = open</i>	145
				B <sub>4</sub> – Not Used	
				B <sub>5</sub> – Not Used	
				B <sub>6</sub> – Not Used	
				B <sub>7</sub> – Not Used	
7	2	mA	0-10000	Current <i>Motor current consumption</i>	200
9	2	W	0-200	Power <i>Motor power adsorption</i>	201
11	2	W	0-200	Power Limit Applied <i>Maximum allowable power</i>	155
13	2	Hz	0-1500	Driving Frequency <i>Read the rotational speed of the pump</i>	203
15	2	Hz	0-1500	Target Frequency <i>Read the target rotational speed</i>	120
17	2	-	0-65536	Cycle Number <i>Number of cycles (start and stop) done by the pump</i>	301
19	2	min	0-65536	Last Cycle Time <i>How long the last cycle lasted</i>	300
21	2	h	0-65536	Pump Life <i>Total pump running time</i>	302
23	4	mBar/Torr/ Pa	-	Pressure Reading <i>Reports the pressure reading in the “pressure unit” selected by Par. Buff., Offset-19, B<sub>5-6</sub></i>	201

**Diagnostic management**

In addition to the ProfiBus six byte standard diagnostic, the interface provides both user diagnostic and static diagnostics functions

The standard diagnostic management is fully compliant with the ProfiBus specification.

During the start-up phase after power on, the first byte in the user diagnostic area, can assume values different from zero.

This byte has the following meaning:

- Bit 0 = 1: controller not responds (RS485 link broken)
- Bit 1 = 1: controller not identified (not compatible with the ProfiBus gateway)
- Bit 2 = 1: first loop of requests not ended (values in the input data are not fully coherent yet)

So, if the first byte is equal to 0, the interface is working properly, otherwise there is a problem.

Each nibble in the bytes following the interface status byte represents the status of the last attempt to write a parameter with following coding (diag status byte):

- 0 Write success
- 1 Controller response was "NACK"
- 2 Controller response was "Unknown window"
- 3 Controller response was "Bad Data Type"
- 4 Controller response was "Over range"
- 5 Controller response was "Bad operation"
- 6 Controller response was an unknown response
- F Parameter not supported by the controller

The ProfiBus external diagnosis services are used to report following unexpected situations:

- **Controller fail:** if the controller goes in fail mode, an external diagnostic service is required and one byte in the diagnostic buffer signals the type of failure.
- **User parameter mismatch:** if the user sets one or more parameters out of their allowed range, a ProfiBus external diagnostic service is required and some bits in the diagnosis frame signals which parameter is wrong (i.e. over range or under range).

**Diagnostic buffer**

Off Set	Meaning		
0	B <sub>0</sub> <i>station non exist</i> (set by master)	Standard diagnostics	
	B <sub>1</sub> <i>station not ready</i> (slave not ready for data exchange)		
	B <sub>2</sub> <i>cfg fault</i> (configuration data doesn't match)		
	B <sub>3</sub> <i>ext diag</i> (slave has external diagnostic data)		
	B <sub>4</sub> <i>not supported</i> (slave doesn't support requested function)		
	B <sub>5</sub> <i>invalid slave response</i> ( slave sets permanent '0')		
	B <sub>6</sub> <i>prm fault</i> (wrong parameter assignment)		
1	B <sub>7</sub> <i>master_lock</i> (slave is parameterised by another master)	Standard diagnostics	
	B <sub>0</sub> <i>prm req</i> (slave has to be re-parameterised)		
	B <sub>1</sub> <i>stat diag</i> (static diagnosis)		
	B <sub>2</sub> fixed '1'		
	B <sub>3</sub> <i>wd_on</i> (response monitoring active)		
	B <sub>4</sub> <i>Freeze mode</i> (received freeze command)		
	B <sub>5</sub> <i>Synch mode</i> (received synch command)		
	B <sub>6</sub> reserved		
B <sub>7</sub> <i>diag deactivated</i> (slave is parameterised by another master)			
2	Reserved		
3	<i>Master Add</i> (master address after parameterisation. FF= without parameter)		
4	Ident number high		
5	Ident number low		
6	External diagnosis "Header" length indication including header		
7	Interface Status	External diagnostic	
	B <sub>0</sub> Controller not responds		
	B <sub>1</sub> Controller not identified		
	B <sub>2</sub> Input data not fully coherent yet		
	B <sub>3</sub> Not used		
B <sub>4-7</sub> Not used			
8	B <sub>7-4</sub> – Start/Stop diag status	External diagnostic	
	B <sub>3-0</sub> – Low Speed diag status		
9	B <sub>7-4</sub> – Soft Start diag status		External diagnostic
	B <sub>3-0</sub> – Vent Valve		
10	B <sub>7-4</sub> – Purge Valve		
	B <sub>3-0</sub> – Mode		
11	B <sub>7-4</sub> – High speed	External diagnostic	
	B <sub>3-0</sub> – Low Speed		

**ERROR MESSAGES**

For a certain type of failure, the controller will self-diagnose the error and the following messages will be displayed.

**NOTE**

*If the pump is not connected, the display will be as shown in the following figure.*

C	H	E	C	K		C	O	N	N	E	C	T	I	O	N
				T	O					P	U	M	P		

Check connection between controller and pump, then press STOP push-button twice to start the pump.

**NOTE**

*If the P1 input connector is not in position with the link or the external interlock connections are open, when the START pushbutton is pressed the display will be as shown in the following figure.*

					W	A	I	T	I	N	G				
					I	N	T	E	R	L	O	C	K		

Disconnect connector P1 and check the link or the external interlock, then install the connector to start the pump.

**NOTE**

*If within each step of the soft start mode the rotational speed of the pump do not reach the planned value within 15 minutes the display will be as shown in the following figure.*

**NOTE**

*If in normal operation (after the starting phase) the current drawn by the pump is higher than programmed (1.8 A), the pump and the inter-connected devices are switched off and the display will be as shown in the following figure.*

		T	O	O		H	I	G	H		L	O	A	D	

Verify that systems has no leaks than press STOP RESET pushbutton twice to start the pump.

Check that pump rotor is free to rotate then press the STOP RESET pushbutton twice to start the pump.

**NOTE**

*If the upper bearing/pump temperature exceeds 60 °C, the pump is shut off, and the display will be as shown in the following figure.*

						P	U	M	P						
						O	V	E	R	T	E	M	P		

The message will stay on until the temperature decreases below threshold value. Press the STOP RESET pushbutton twice to start the pump.

**NOTE**

*If the controller transformer temperature exceeds 90°C, the pump is shut off, and the display will be as shown in the following figure.*

						C	O	N	T	R	O	L	L	E	R
						O	V	E	R	T	E	M	P		

The message will stay on until the temperature decreases below threshold value. Press the STOP RESET pushbutton twice to start the pump.

						P	O	W	E	R		F	A	I	L

Indicates a fault in the circuit of the controller used to power the pump.

**NOTE**

*If the pump is stopped by an emergency stop signal provided via a remote contact, the display will be as shown in the following figure.*

						S	Y	S	T	E	M				
						O	V	E	R	R	I	D	E		

Remove the controller power cable and check the emergency condition.

Then reconnect the power cable and press the START pushbutton to start the pump.



Controller power supply circuitry is faulty, or the Controller received a spike.

Press the START push-button twice to start the pump. Should the message still be present, call the Varian service.

Check connections and shortages between pump and controller, then press the STOP RESET pushbutton twice to start the pump.

**ORDERABLE PARTS**

DESCRIPTION	PART NUMBER
Turbo-V 301-AG	969-8991
Turbo-V 301-AG with RS-232/485 option	969-8992
Turbo-V 301-AG with Profibus option	969-8993
Turbo-V 301-AG Air Cooling Kit (0.5 m cable)	969-9291
Turbo-V 301-AG Air Cooling Kit extension cable (5 m)	969-9940
Vent Valve N.O. 0,5 mm orifice (0,5 m cable)	969-9844
Vent Valve extension cable (5 m)	969-9941
EyeSys Mini-IMG Gauge cable (1 m)	969-9943
EyeSys Mini-IMG Gauge (special)	R1400301**** (not yet available)
Gauge extension cable (5 m)	969-9944
Mains cable NEMA plug (3 m)	969-9958
Mains cable european plug (3 m)	969-9957



# Request for Return



1. A Return Authorization Number (RA#) **WILL NOT** be issued until this Request for Return is completely filled out, signed and returned to Varian Customer Service.
2. Return shipments shall be made in compliance with local and international **Shipping Regulations** (IATA, DOT, UN).
3. The customer is expected to take the following actions to ensure the **Safety** of workers at Varian: (a) Drain any oils or other liquids, (b) Purge or flush all gasses, (c) Wipe off any excess residues in or on the equipment, (d) Package the equipment to prevent shipping damage, (for Advance Exchanges please use packing material from replacement unit).
4. Make sure the shipping documents clearly show the RA# and then return the package to the Varian location nearest you.

### North and South America

Varian Vacuum Technologies  
 121 Hartwell Ave  
 Lexington, MA 02421  
 Phone : +1 781 8617200  
 Fax: +1 781 8609252

### Europe and Middle East

Varian SpA  
 Via Flli Varian 54  
 10040 Leini (TO) – ITALY  
 Phone: +39 011 9979111  
 Fax: +39 011 9979330

### Asia and ROW

Varian Vacuum Technologies  
 Local Office

### **CUSTOMER INFORMATION**

Company name: .....	
Contact person: Name: .....	Tel: .....
Fax: .....	E-Mail: .....
Ship Method: .....	Shipping Collect #: ..... P.O.#: .....
<u>Europe only:</u> VAT reg. Number: .....	<u>USA only:</u> <input type="checkbox"/> Taxable <input type="checkbox"/> Non-taxable
Customer Ship To: .....	Customer Bill To: .....
.....	.....
.....	.....

### **PRODUCT IDENTIFICATION**

Product Description	Varian P/N	Varian S/N	Purchase Reference

### **TYPE OF RETURN** (check appropriate box)

<input type="checkbox"/> Paid Exchange	<input type="checkbox"/> Paid Repair	<input type="checkbox"/> Warranty Exchange	<input type="checkbox"/> Warranty Repair	<input type="checkbox"/> Loaner Return
<input type="checkbox"/> Credit	<input type="checkbox"/> Shipping Error	<input type="checkbox"/> Evaluation Return	<input type="checkbox"/> Calibration	<input type="checkbox"/> Other .....

### **HEALTH and SAFETY CERTIFICATION**

Varian Vacuum Technologies **CAN NOT ACCEPT** any equipment which contains **BIOLOGICAL HAZARDS** or **RADIOACTIVITY**. Call Varian Customer Service to discuss alternatives if this requirement presents a problem.

The equipment listed above (check one):

**HAS NOT** been exposed to any toxic or hazardous materials

OR

**HAS** been exposed to any toxic or hazardous materials. In case of this selection, check boxes for any materials that equipment was exposed to, check all categories that apply:

Toxic    Corrosive    Reactive    Flammable    Explosive    Biological    Radioactive

List all toxic or hazardous materials. Include product name, chemical name and chemical symbol or formula.

.....

Print Name: ..... Customer Authorized Signature: .....

Print Title: ..... Date: ...../...../.....

**NOTE:** If a product is received at Varian which is contaminated with a toxic or hazardous material that was not disclosed, **the customer will be held responsible** for all costs incurred to ensure the safe handling of the product, and **is liable** for any harm or injury to Varian employees as well as to any third party occurring as a result of exposure to toxic or hazardous materials present in the product.

Do not write below this line

Notification (RA)#: ..... Customer ID#: ..... Equipment #: .....

**FAILURE REPORT**

**TURBO PUMPS and TURBOCONTROLLERS**

<input type="checkbox"/> Does not start <input type="checkbox"/> Does not spin freely <input type="checkbox"/> Does not reach full speed <input type="checkbox"/> Mechanical Contact <input type="checkbox"/> Cooling defective	<input type="checkbox"/> Noise <input type="checkbox"/> Vibrations <input type="checkbox"/> Leak <input type="checkbox"/> Overtemperature	<b>POSITION</b> <input type="checkbox"/> Vertical <input type="checkbox"/> Horizontal <input type="checkbox"/> Upside-down <input type="checkbox"/> Other: .....	<b>PARAMETERS</b> Power:                      Rotational Speed: Current:                     Inlet Pressure: Temp 1:                      Foreline Pressure: Temp 2:                      Purge flow: <hr/> OPERATION TIME:
<b>TURBOCONTROLLER ERROR MESSAGE:</b>			

**ION PUMPS/CONTROLLERS**

<input type="checkbox"/> Bad feedthrough <input type="checkbox"/> Vacuum leak <input type="checkbox"/> Error code on display	<input type="checkbox"/> Poor vacuum <input type="checkbox"/> High voltage problem <input type="checkbox"/> Other
Customer application:	

**VALVES/COMPONENTS**

<input type="checkbox"/> Main seal leak <input type="checkbox"/> Solenoid failure <input type="checkbox"/> Damaged sealing area	<input type="checkbox"/> Bellows leak <input type="checkbox"/> Damaged flange <input type="checkbox"/> Other
Customer application:	

**LEAK DETECTORS**

<input type="checkbox"/> Cannot calibrate <input type="checkbox"/> Vacuum system unstable <input type="checkbox"/> Failed to start	<input type="checkbox"/> No zero/high background <input type="checkbox"/> Cannot reach test mode <input type="checkbox"/> Other
Customer application:	

**INSTRUMENTS**

<input type="checkbox"/> Gauge tube not working <input type="checkbox"/> Communication failure <input type="checkbox"/> Error code on display	<input type="checkbox"/> Display problem <input type="checkbox"/> Degas not working <input type="checkbox"/> Other
Customer application:	

**PRIMARY PUMPS**

<input type="checkbox"/> Pump doesn't start <input type="checkbox"/> Doesn't reach vacuum <input type="checkbox"/> Pump seized	<input type="checkbox"/> Noisy pump (describe) <input type="checkbox"/> Over temperature <input type="checkbox"/> Other
Customer application:	

**DIFFUSION PUMPS**

<input type="checkbox"/> Heater failure <input type="checkbox"/> Doesn't reach vacuum <input type="checkbox"/> Vacuum leak	<input type="checkbox"/> Electrical problem <input type="checkbox"/> Cooling coil damage <input type="checkbox"/> Other
Customer application:	

**FAILURE DESCRIPTION**

(Please describe in detail the nature of the malfunction to assist us in performing failure analysis):

**NOTA:** Su richiesta questo documento è disponibile anche in Tedesco, Italiano e Francese.  
**REMARQUE :** Sur demande ce document est également disponible en allemand, italien et français.  
**HINWEIS:** Auf Anfrage ist diese Unterlage auch auf Deutsch, Italienisch und Französisch erhältlich.

## Sales and Service Offices

### France and Benelux

#### Varian s.a.

7 Avenue des Tropiques  
Z.A. de Courtaboeuf - B.P. 12  
Les Ulis cedex (Orsay) 91941  
France  
Tel: (33) 1 69 86 38 84  
Fax: (33) 1 69 86 29 88  
From Benelux Tel: (31) 118 67 15 70  
From Benelux Fax: (31) 118 67 15 69

### Canada

#### Central coordination through:

#### Varian Vacuum Technologies

121 Hartwell Avenue  
Lexington, MA 02421  
USA  
Tel: (781) 861 7200  
Fax: (781) 860 5437  
Toll Free # 1 (800) 882 7426

### China

#### Varian Technologies - Beijing

Rm 1648 Central Tower South Wing  
Beijing Junefield Plaza  
No. 10 XuanWuMenWai Street  
Beijing 100052  
P.R. China  
Tel: (86) 10 63108550  
Fax: (86) 10 63100141  
Toll Free: 800 820 6556

### Germany and Austria

#### Varian Deutschland GmbH

Alsfelder Strasse 6  
Postfach 11 14 35  
64289 Darmstadt  
Germany  
Tel: (49) 6151 703 353  
Fax: (49) 6151 703 302

### India

#### Varian India PVT LTD

101-108, 1st Floor  
1010 Competent House  
7, Nangal Raya Business Centre  
New Delhi 110 046  
India  
Tel: (91) 11 28521171  
Fax: (91) 11 28521173

### Italy

#### Varian Inc.

#### Vacuum Technologies

Via F.lli Varian 54  
10040 Leini, (Torino)  
Italy  
Tel: (39) 011 997 9 111  
Fax: (39) 011 997 9 350

### Japan

#### Varian Vacuum Technologies

Sumitomo Shibaura Building, 8th Floor  
4-16-36 Shibaura  
Minato-ku, Tokyo 108  
Japan  
Tel: (81) 3 5232 1253  
Fax: (81) 3 5232 1263  
Toll Free: 0120 655 040

### Korea

#### Varian Technologies Korea, Ltd

Shinsa 2nd Bldg. 2F  
966-5 Daechi-dong  
Kangnam-gu, Seoul  
Korea 135-280  
Tel: (82) 2 3452 2452  
Fax: (82) 2 3452 2451  
Toll Free: 080 222 2452

### Mexico

#### Varian, S. de R.L. de C.V.

Concepcion Beistegui No 109  
Col Del Valle  
C.P. 03100  
Mexico, D.F.  
Tel: (52) 5 523 9465  
Fax: (52) 5 523 9472

### Taiwan

#### Varian Technologies Asia Ltd.

14F-6, No.77, Hsin Tai Wu Rd., Sec. 1  
Hsi chih, Taipei Hsien  
Taiwan, R.O.C.  
Tel: (886) 2 2698 9555  
Fax: (886) 2 2698 9678  
Toll Free: 0800 051342

### UK and Ireland

#### Varian Ltd.

6 Mead Road  
Oxford Industrial Park - Yarnton  
Oxford OX5 1QU - England  
Tel: (44) 1865 291570  
Fax: (44) 1865 291571

### United States

#### Varian Vacuum Technologies

121 Hartwell Avenue  
Lexington, MA 02421  
USA  
Tel: (781) 861 7200  
Fax: (781) 860 5437

### Other Countries

#### Varian Inc.

#### Vacuum Technologies

Via F.lli Varian 54  
10040 Leini, (Torino)  
Italy  
Tel: (39) 011 997 9 111  
Fax: (39) 011 997 9 350

### Customer Support & Service:

#### North America

Toll-Free: 1 800 882 7426  
vtl.technical.support@varianinc.com

#### Europe

Tel: 00 800 234 234 00  
vtt.technical.support@varianinc.com

#### China

Toll-Free: 800 820 8266  
vtc.technical.support@varianinc.com

#### Japan

Toll-Free: 0120 655 040  
vtj.technical.support@varianinc.com

#### Korea

Toll-Free: 080 222 2452  
vtk.technical.support@varianinc.com

#### Taiwan

Toll-Free: 0 800 051 342  
vtw.technical.support@varianinc.com

### Worldwide Web Site, Catalog and Order On-line:

[www.varianinc.com](http://www.varianinc.com)

Representative in most countries



# VARIAN