

# Benchmark of Multipactoring Simulations on an ILC Shape TE011 SRF Cavity

Haipeng Wang, Gigi Ciovati, Asavari Dhavale, JLab

Lixin Ge, Zenghai Li, Kwok Ko, SLAC

04.2010

Work supported by Department of Energy of US in Nuclear Physics  
and Scientific Discovery through Advanced Computing programs  
(COMPASS).

## Experiment Motivation to Study the Q-slope Effect by High Magnetic Field

- Quench, electromagnetic or thermal dynamic? -- Shining a laser beam to the hot spot on a SRF TE011 cavity to see the  $\Delta T$  or Q drop change.
- Explore the influence of pinned vortices in generating anomalous RF losses, particularly at high-field (Q-drop region). Depin vortices by applying a local thermal gradient using a laser beam directed to the cavity surface which shows high RF losses.
- Explore Laser Scanning Microscopy as a non-destructive technique to identify lossy regions of a cavity with better resolution than thermometry.
- G. Ciovati and A. Gurevich, PRST A&B, 11, 122001 (2008).

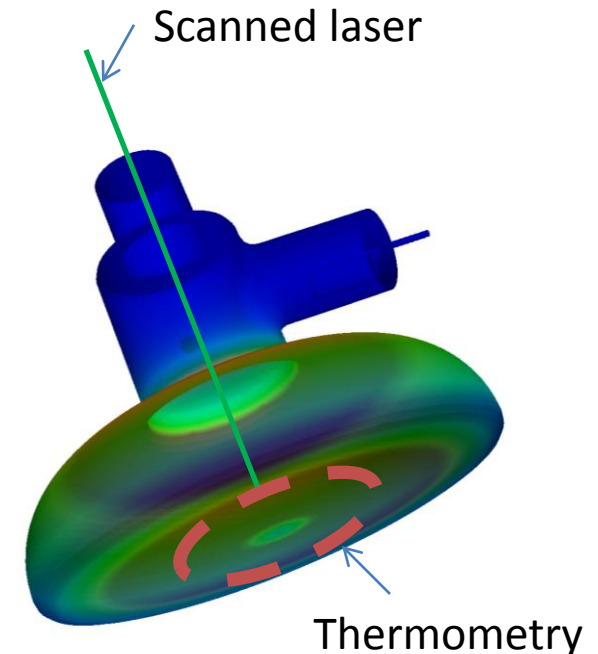
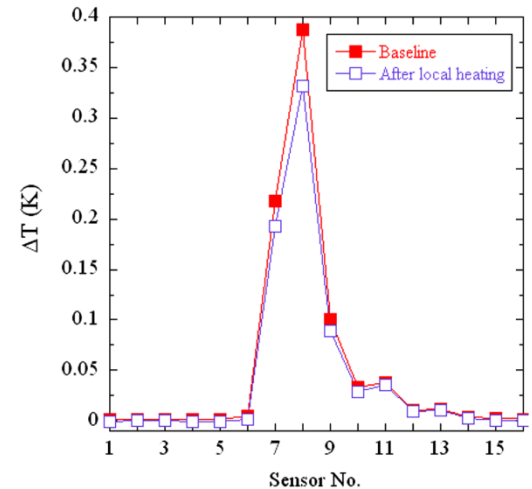

# Experiment Setup in ILC Shape TE011 Cavity



TE011 mode: magnetic field

electric field

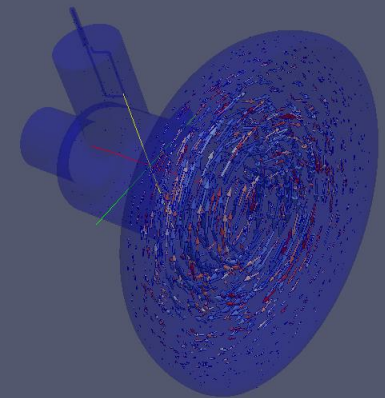
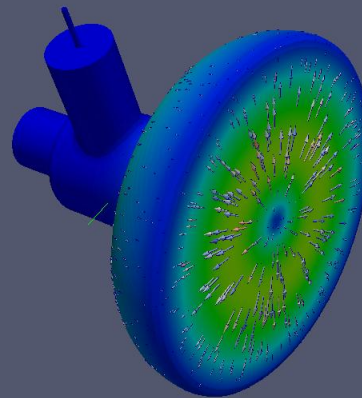

LHI Large-Grain Nb cavity

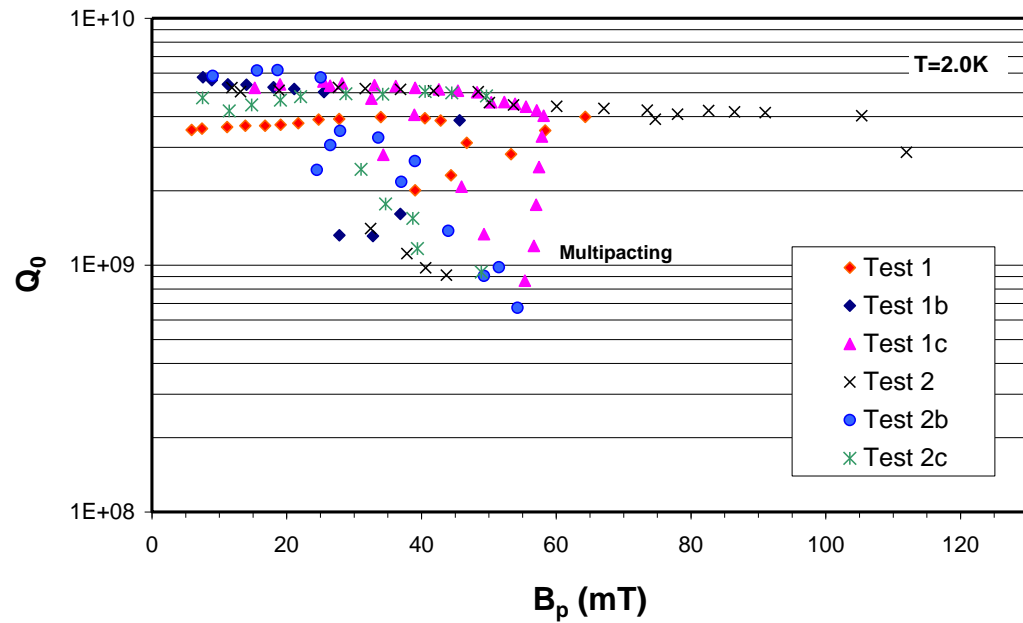

But multipactoring problem

LHI Large-Grain Nb cavity

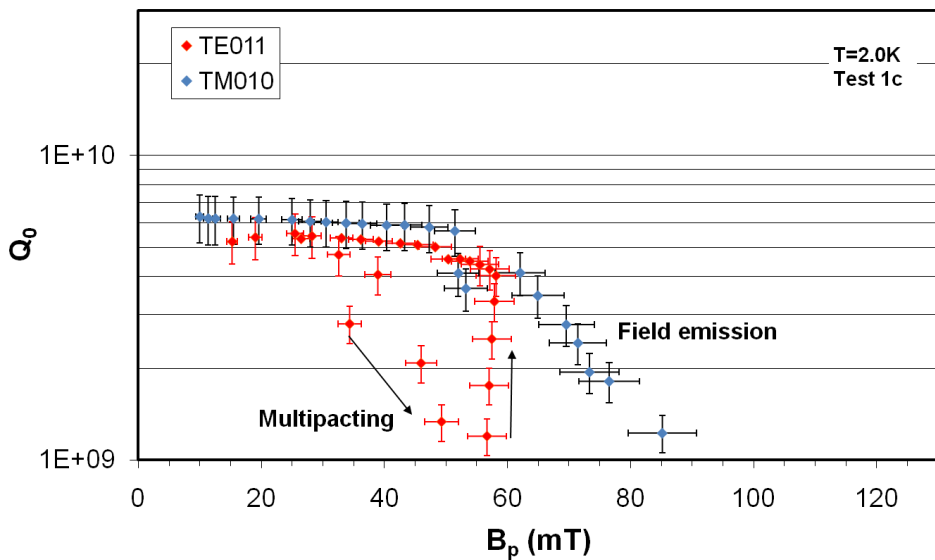

LHI Large-Grain Nb cavity

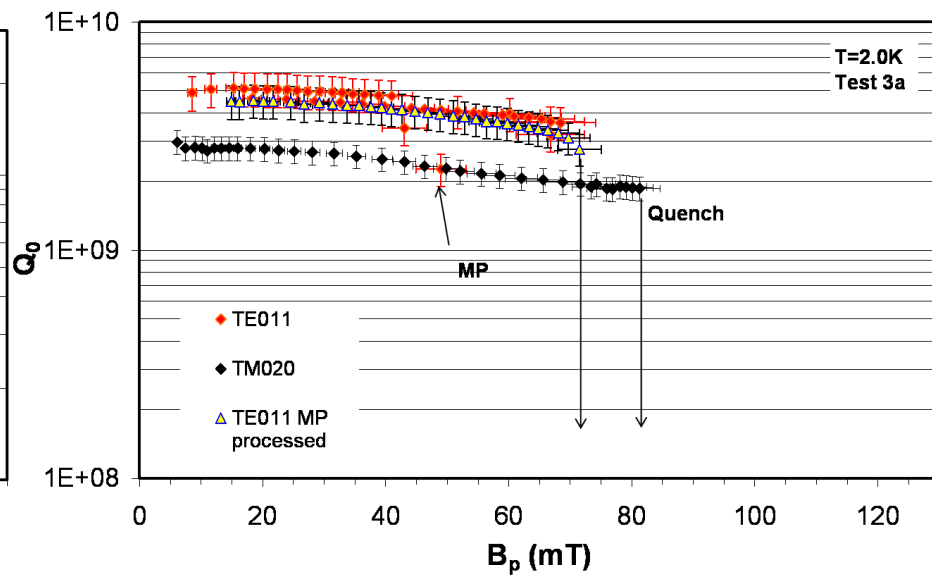

# Omega3P/Track3P simulations supported by SLAC's ACD group

ILC TE011 cavity Model

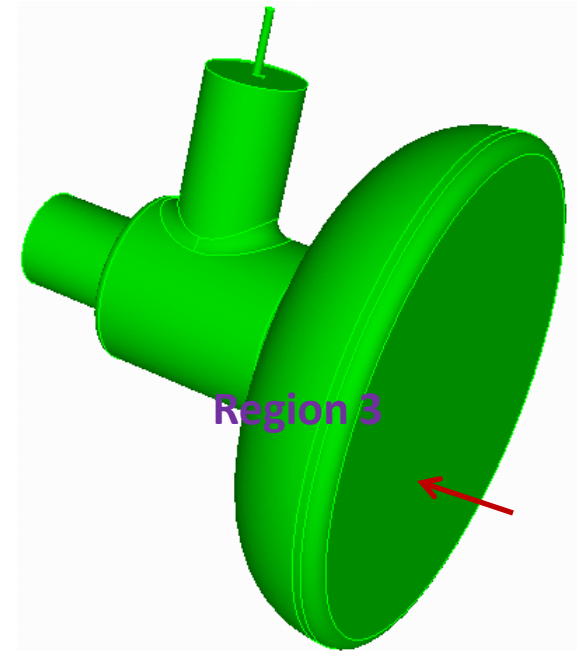
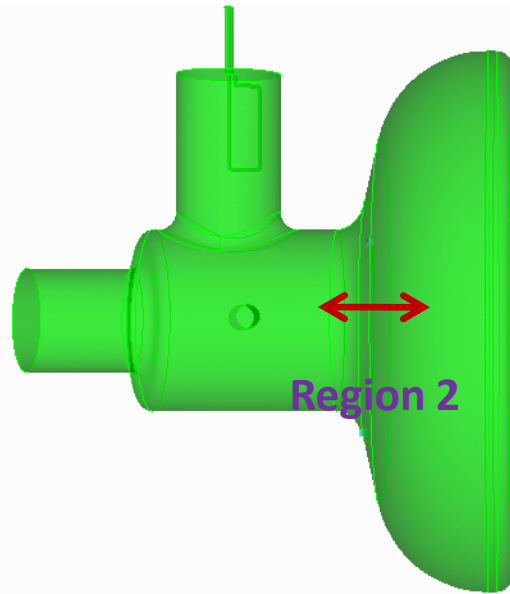
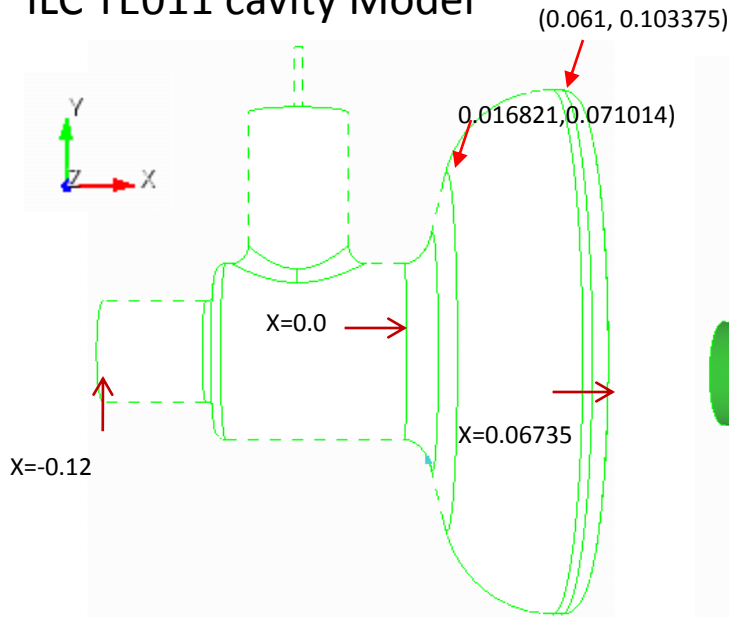

	Region 2	Region 3
Location	$0 < x < 0.035\text{m}$	$X = 0.06735\text{m}$
Order	1, 2, 3,	2, 3
Points	1	1

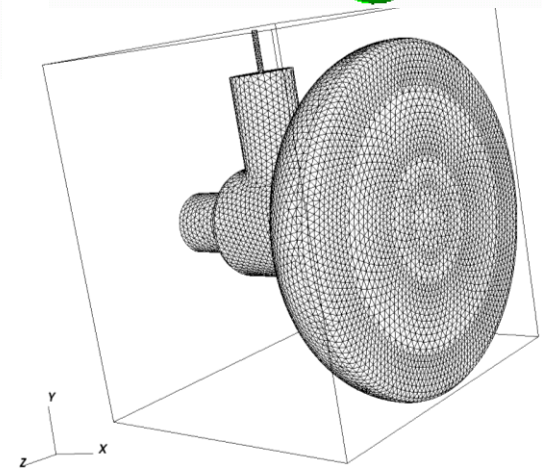

Meshing with tetra10, 4mm 243966 elements

# Region 2

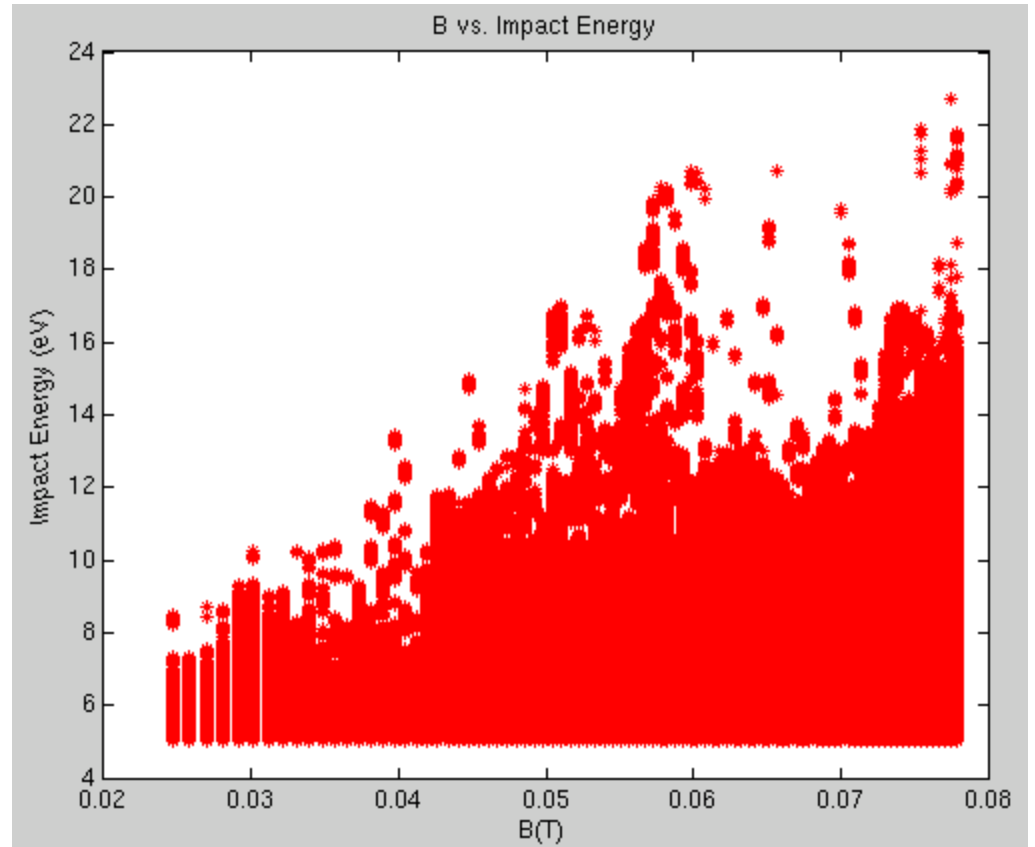
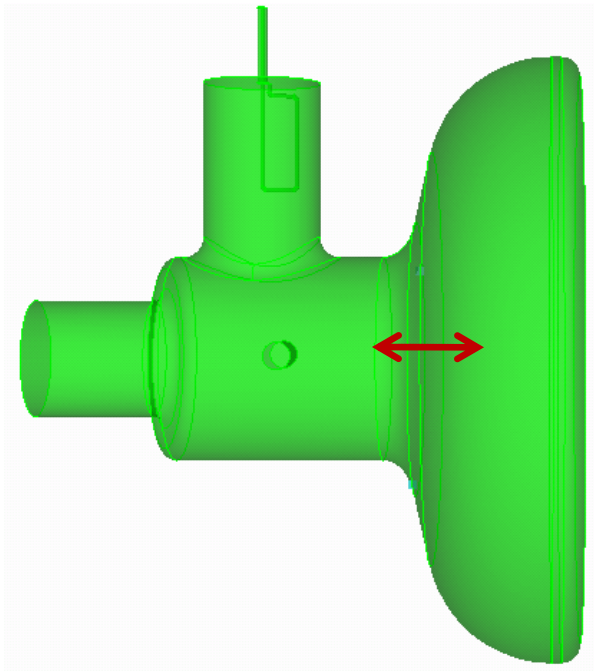

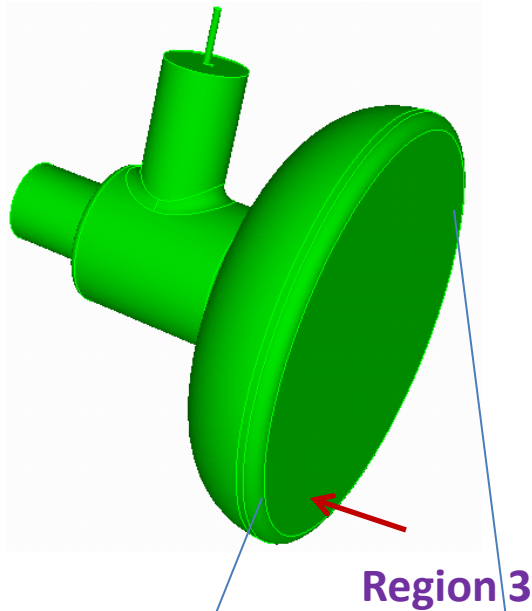

Region 3

One point, 1<sup>st</sup> or 2<sup>nd</sup> 3<sup>rd</sup> order resonant trajectory

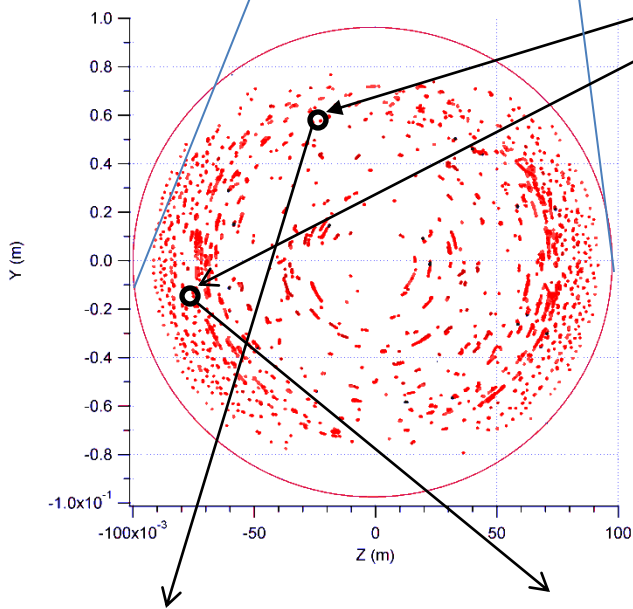
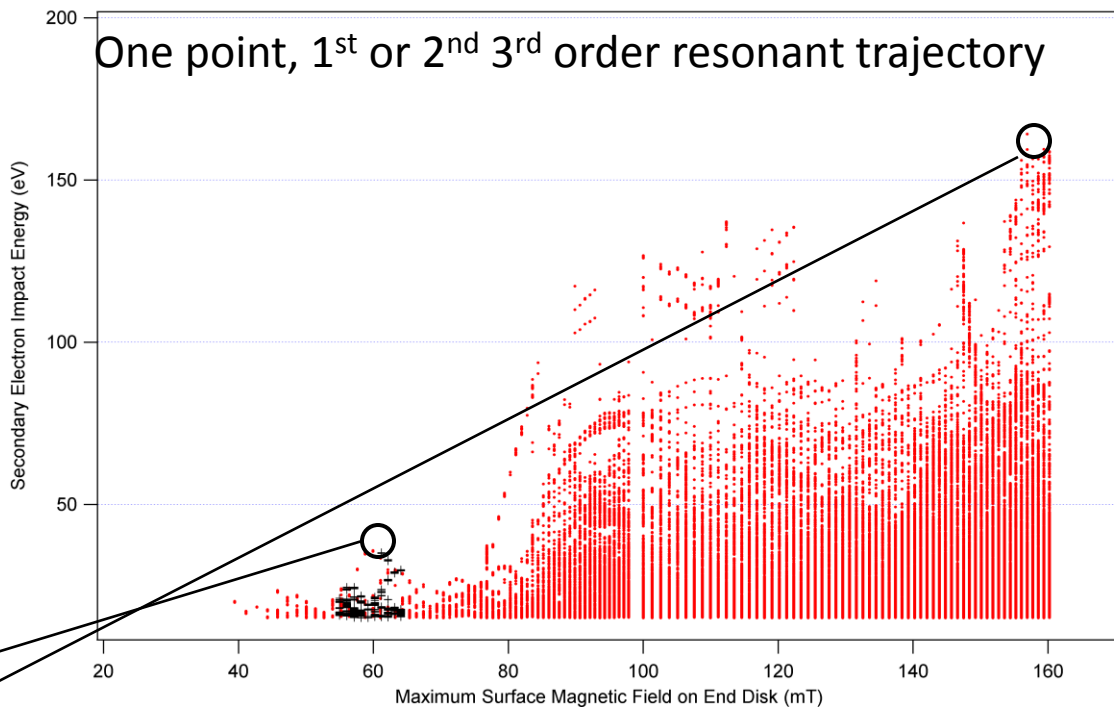

Trajectory lookup

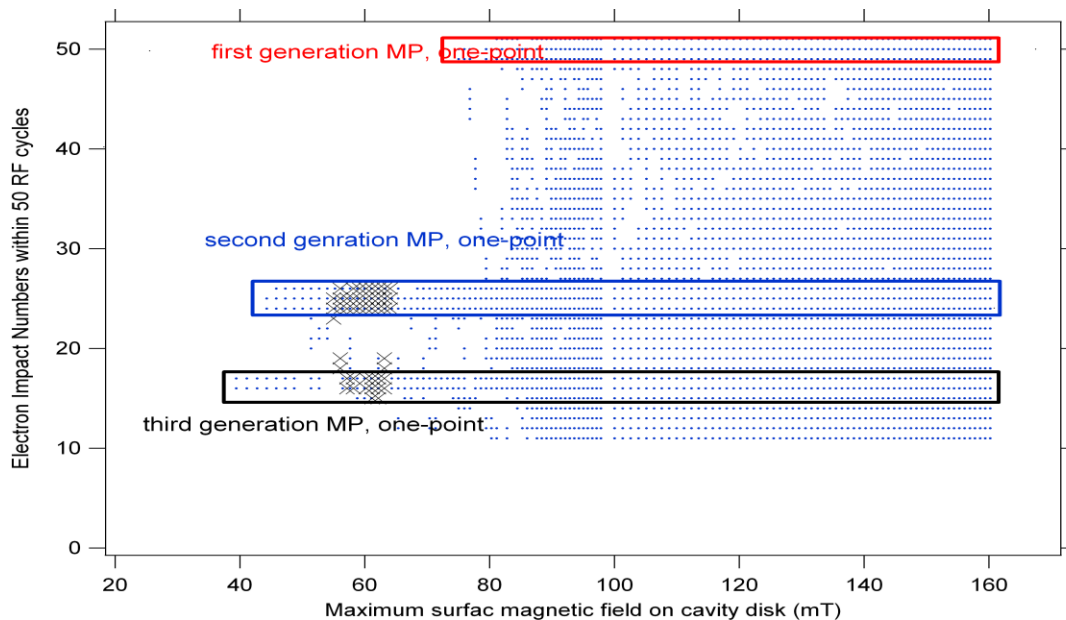

# Multipactor Trajectories at Cavity Bottom Disk

Field Level: 60 mT, Impact Energy: 31 eV, 2<sup>nd</sup> Order, One-Point

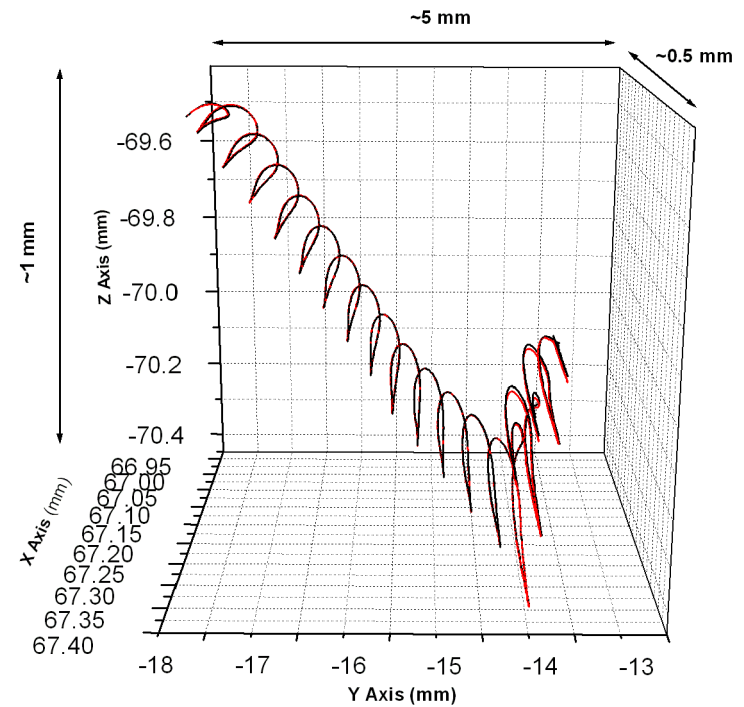
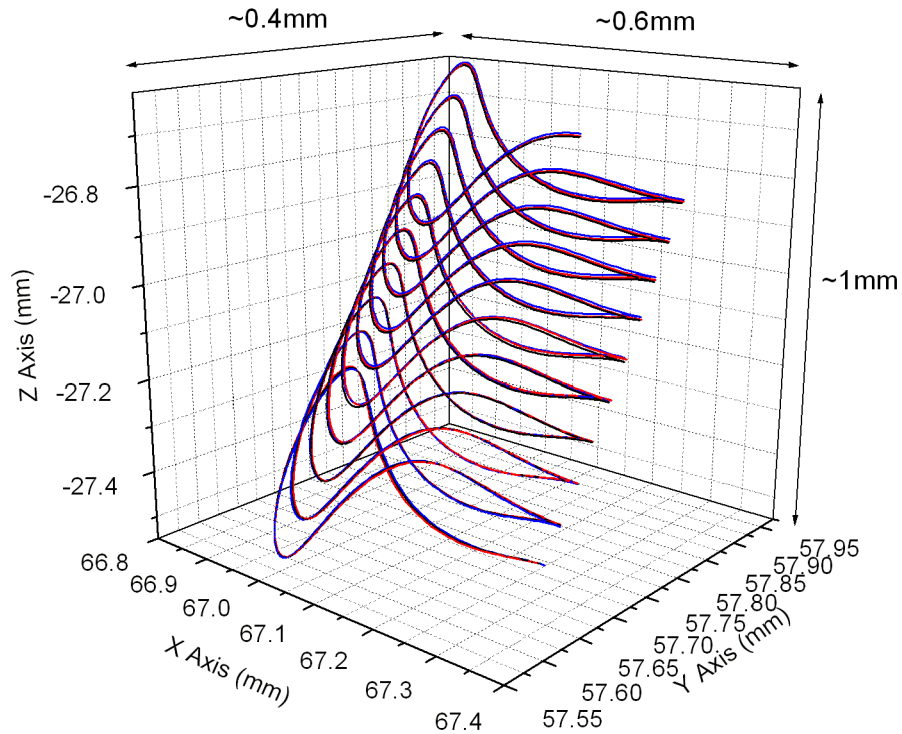

Field Level: 157 mT, Impact Energy: 170 eV, 1<sup>st</sup> Order, One-Point



# Experiment Movie Clips

1. T-maps screen

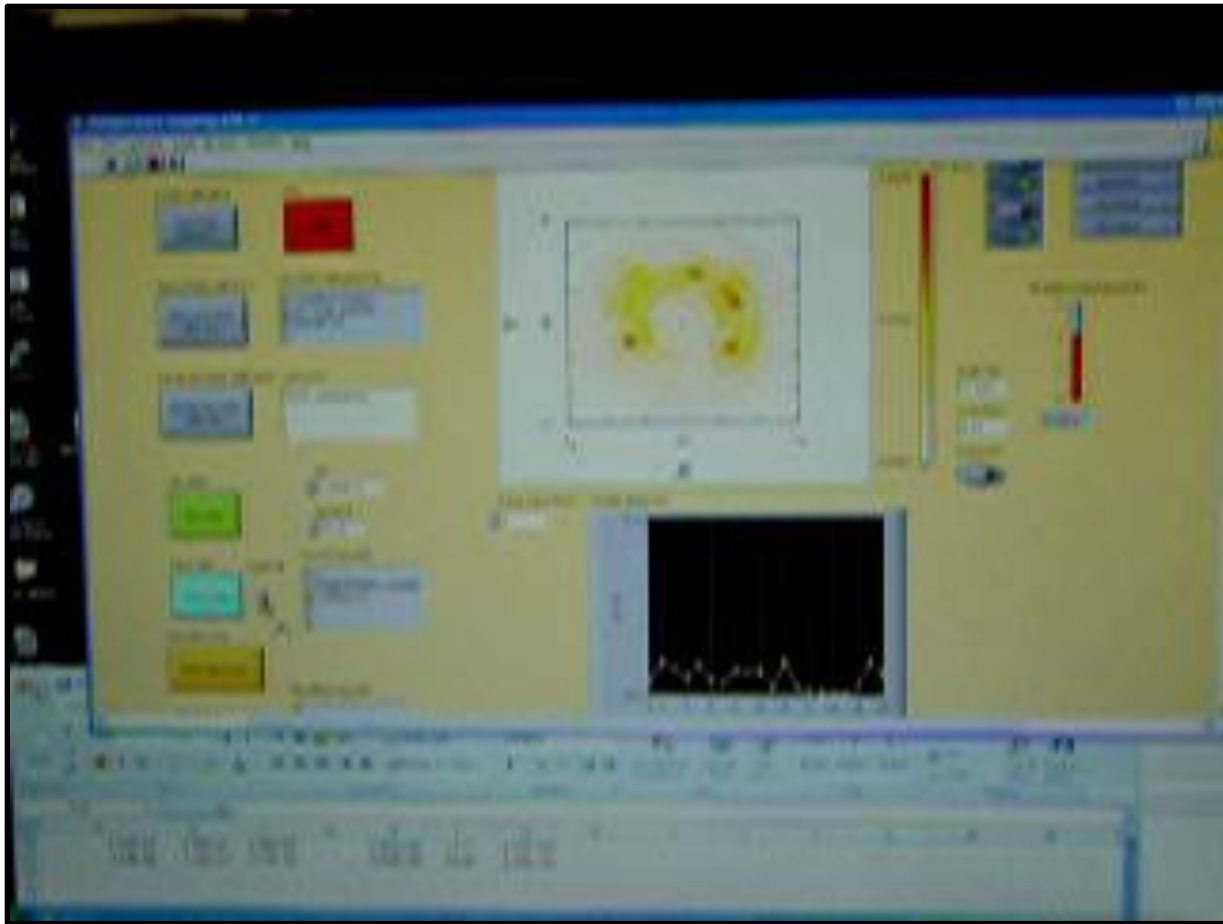

2. Oscillate scope

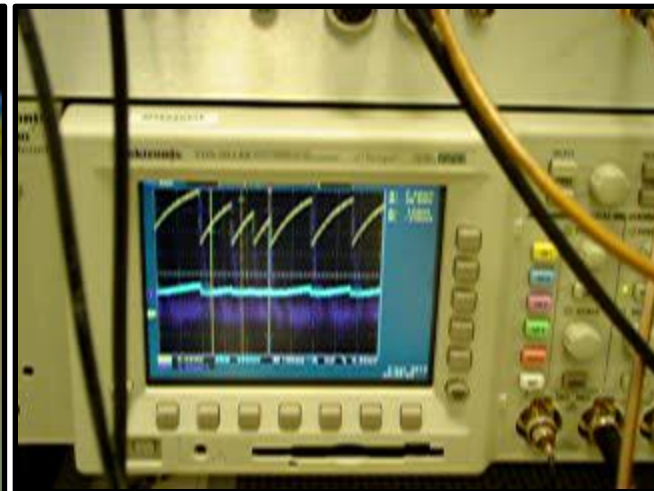

3. Thermometry setup

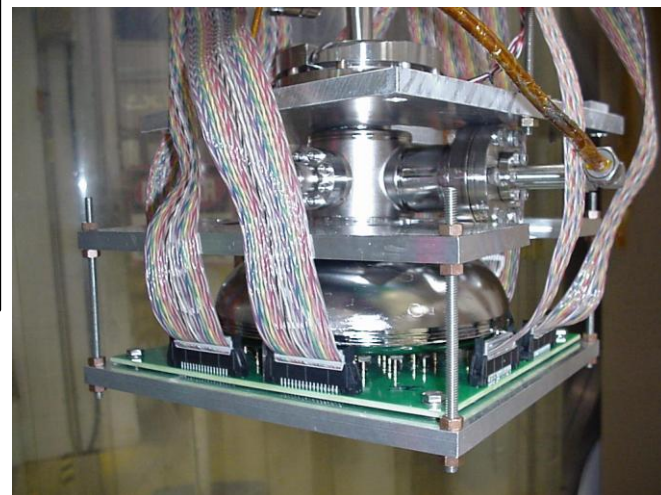

## Examples of T-maps during MP processing at Bp=43 mT

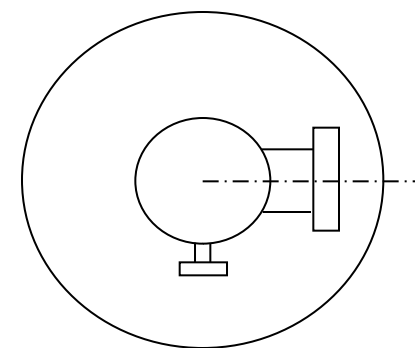
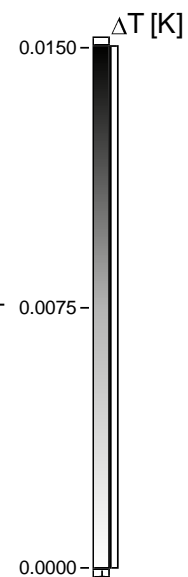
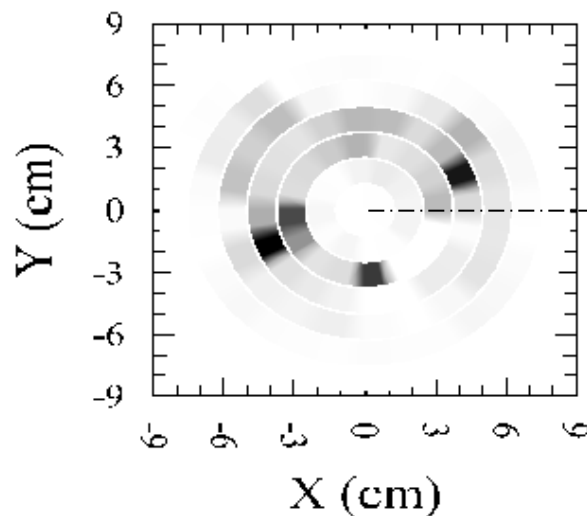
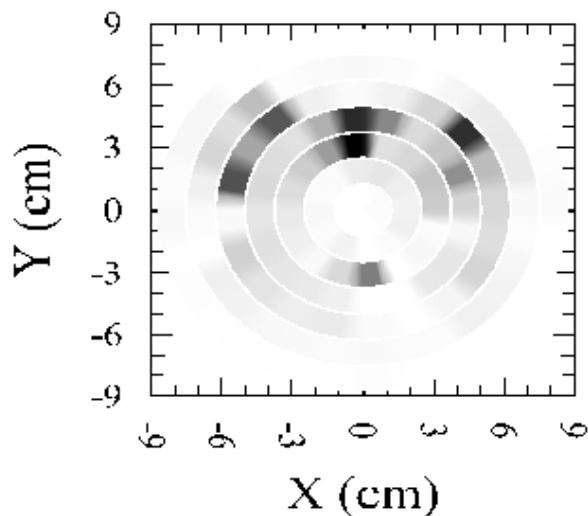

## Examples of T-maps during MP processing at Bp=50 mT

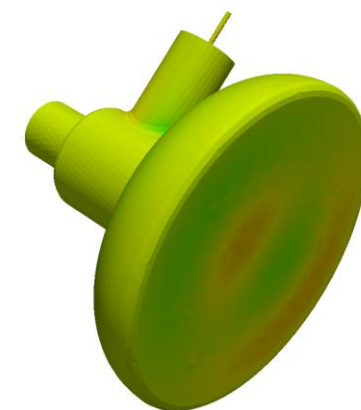
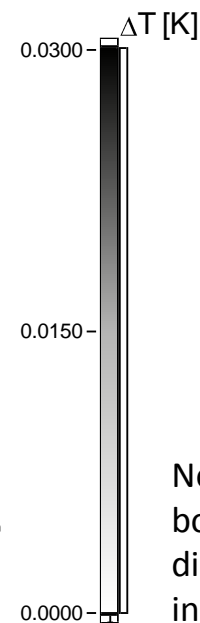
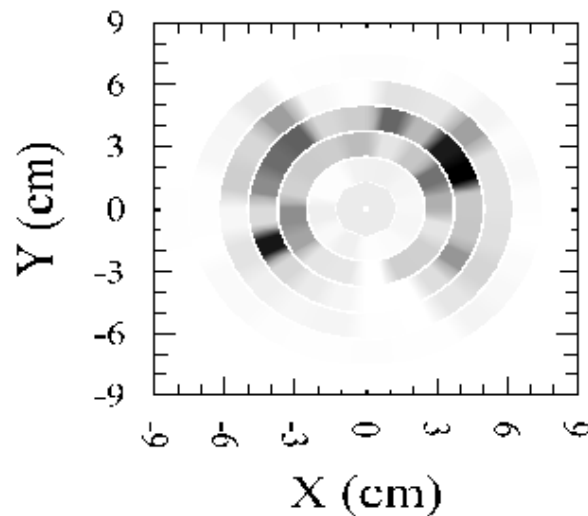
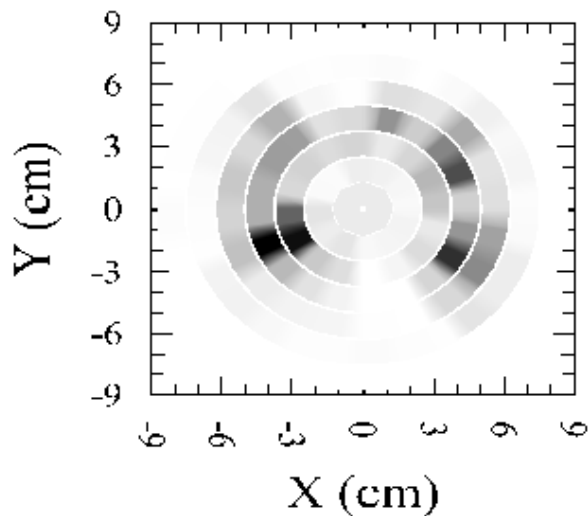

Normal electric field on bottom plate shows a dipole mode perturbation in TE<sub>011</sub> mode

# Microwave Studio and MAFIA-2D calculated modes frequencies (MHz) on different models

Mode ID	model A	model B	model C	model D	model E	model F	model G	model H	model I	model J
TM 010			1250.46							
TM 110			1815.62							
			1816.24							
TM 210			2441.81							
			2442.13							
TM 020			2657.65							
TM 310		3016.27/3016.28	3016.17			3016.18/3016.45	3016.25/3016.32	3016.29/3016.29	3016.24/3016.43	3016.30/3016.33
			3016.45							
TE 210		3198.43/3198.36	3198.26	3275.38/3275.44	3113.15/3132.80	3198.19/3198.21	3198.18/3198.26	3195.39/3198.06	3197.2/3198.1	3195.98/3198.25
TM 111	3222.2	3222.37/3222.38		3198.47/3222.8	3196.65/3221.43	3217.02/3220.24	3219.59/3219.71	3193.20/3193.16	3191.27/3227.15	3194.00/3194.89
TM 011	3301.26	3297.75	3286.13	3339.99	3200.08	3297.59	3298.26	3326.33	3354.68	3327.75
TE 011	3322.59	3311.51	3311.59	3390.07	3260.003	3311.56	3311.50	3311.48	3311.48	3311.46
beampipe mode										
TM 112	3582.41				3492.99					
TM011 bp		3456.72			3380.4	3457.82	3464.44	3157.93	3261.94	3170.7
coupler mode					3492.03					

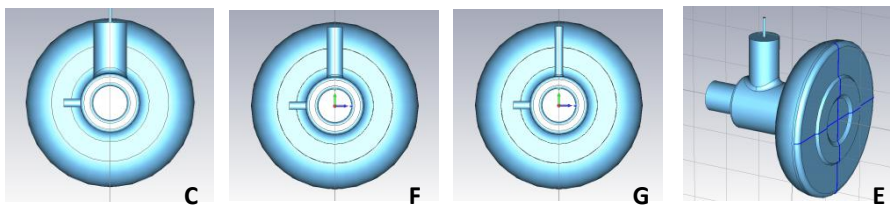

model A	MAFIA-2D without coupler can		
model B	without coupler can		
model C	with 40mm dia. coupler can		
model D	with 40mm dia. coupler can and bump		
model E	with 40mm dia. Coupler can and groove		
model F	with 20 mm dia. coupler can		
model G	with 10 mm dia. coupler can		
model H	with four 40mm dia coupler cans		
model I	with two 40 mm two 10 mm dia. coupler cans		
model J	with four 40mm dia coupler cans but three of them shorter		

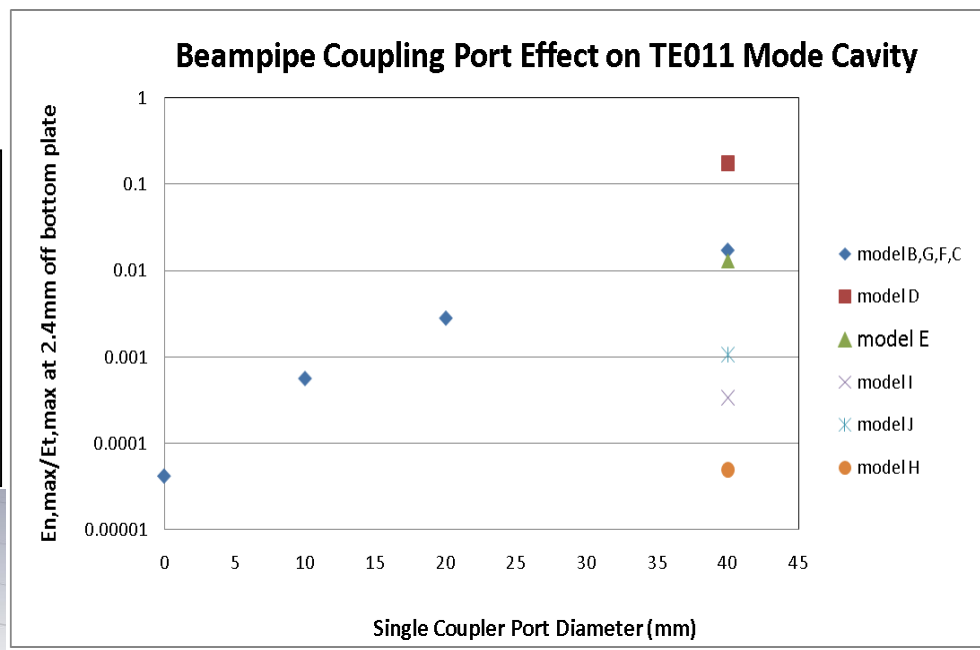
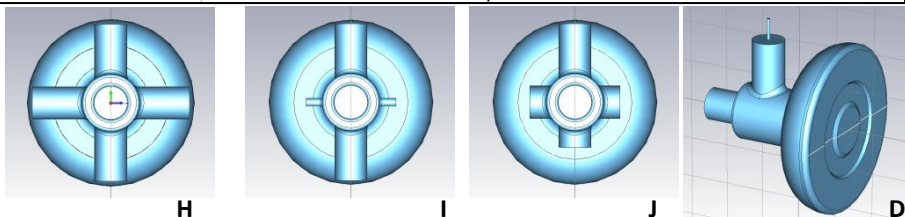

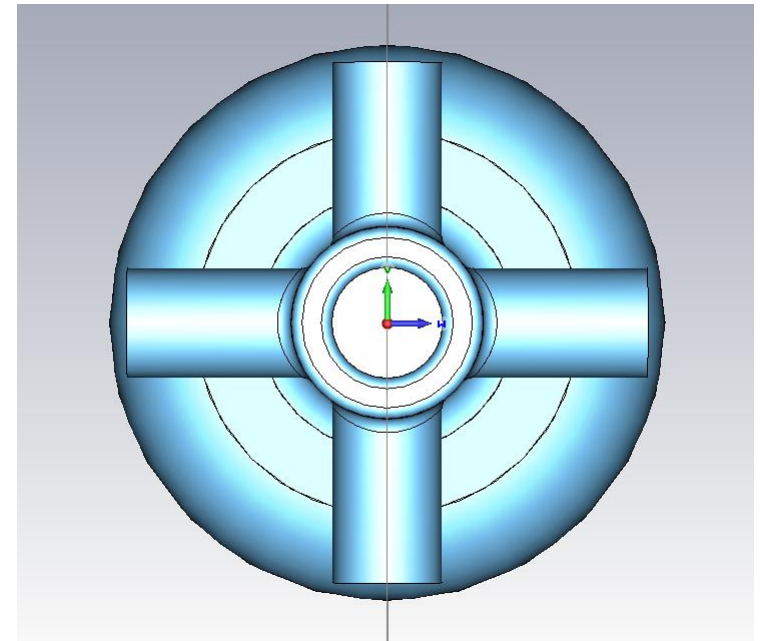
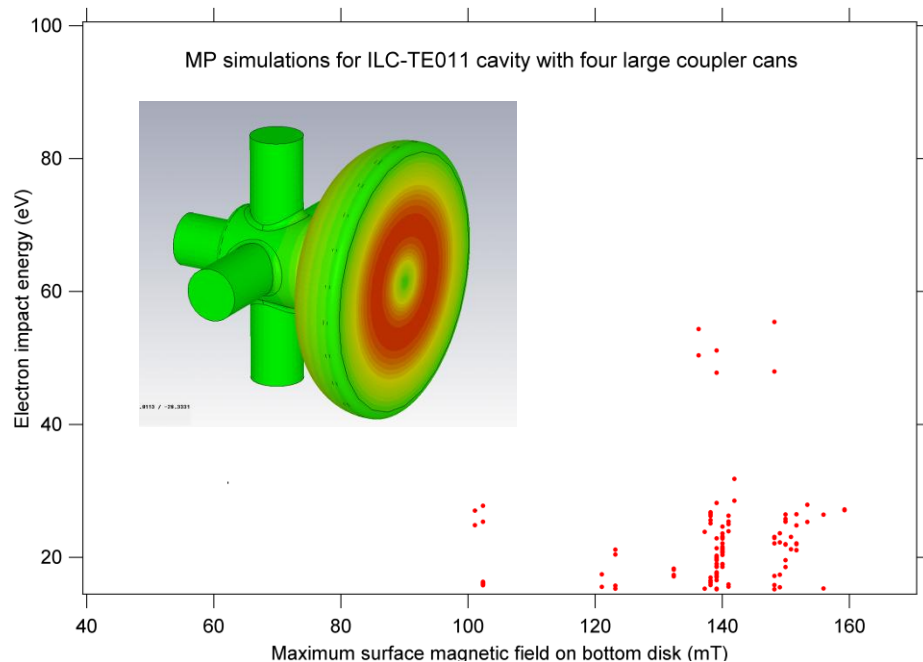

### MP suppression solution:

- Using four coupler ports to make x-y symmetry of the TE011 mode.
- $E_{nmax}/E_{tmax}$  at 2.4 mm off surface reduces to  $5e-5$  on the bottom plate.
- Only 3<sup>rd</sup> and 4<sup>th</sup> orders of MP at high field levels.
- Only the MP at 140mT could be hard barrier.

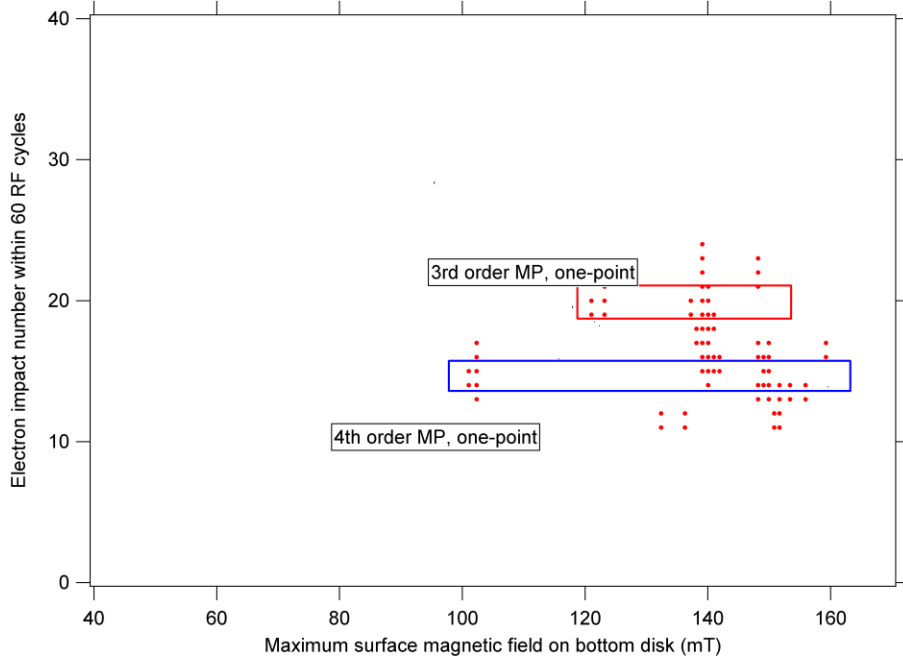

## Summary:

- 3D multipactoring problem in a TE011 SRF cavity has been successfully simulated with SLAC ACD's codes, Omega3P (eigen solver) and Track3P (particle tracking).
- The electron multipactor impact location and field levels have been confirmed by the experimental data.
- Cavity structure modification to reduced the electron extraction effect have been investigated. Reduction to the dipole degeneration of the TM111 mode is the key way to minimize the normal electron field component on the multipactoring surface.
- A best and engineering wise solution of a modification to the coupling structure has been given to suppress the multipactoring.
- A soft, multipactoring barrier after the structure modification needs to be further confirmed in the next experiment. It is expected can be processed away by a high power RF processing.