

## FEATURES

- High Torque Stepper Motors
- Hybrid technologies
- Permanent magnet

# RS PRO Hybrid, Permanent Magnet Stepper Motor, 2.8 V, 5mm Shaft Diameter

RS Stock No.: 535-0489



RS Professionally Approved Products bring to you professional quality parts across all product categories. Our product range has been tested by engineers and provides a comparable quality to the leading brands without paying a premium price.

## Product Description

High Torque Hybrid Stepper Motors are motion systems allowing to have a high positioning precision. With their high power already at low speed, their stall torque and the possibility to divide the steps in micro steps, stepper motors can provide direct and precise motions in a small volume

## General Specifications

<b>Stepper Motor Type</b>	Hybrid, Permanent Magnet Stepper
<b>Step Angle</b>	1.8°
<b>Step Angle Accuracy (Full Step, No Load)</b>	±5%
<b>Holding Torque</b>	44Ncm
<b>Detent Torque</b>	25mNm
<b>Output Speed</b>	186rpm
<b>Number of Pole Pairs</b>	1
<b>Applications</b>	Floppy disk drives, flatbed scanners, computer printers, plotters, slot machines
<b>Number Of Leads</b>	4

### Electrical Specifications

<b>Voltage Rating</b>	2.8V
<b>Current Per Phase</b>	1.68A
<b>Number Of Wires</b>	4
<b>Winding Arrangement</b>	Bipolar; Parallel; Series; Unipolar; Unparallel
<b>Resistance Per Phase</b>	1.65Ohm
<b>Resistance Accuracy</b>	±10%
<b>Inductance Per Phase</b>	2.8mH
<b>Inductance Accuracy</b>	±20%
<b>Rotor Inertia</b>	68g-cm <sup>2</sup>
<b>Insulation Resistance</b>	100MOhm min. 500VDC
<b>Dielectric Strength</b>	500VAC for one minute
<b>Insulation Class</b>	B

### Mechanical Specifications

<b>Shaft Diameter</b>	5mm
<b>Shaft Length</b>	22mm
<b>Depth</b>	47mm
<b>Frame Size</b>	28mm x 28mm
<b>Weight</b>	0.35kg
<b>Shaft Radial Play</b>	0.02 Max. (450G Load)
<b>Shaft Axial Play</b>	0.08 Max. (450G Load)
<b>Maximum Radial Force</b>	28N (20mm from front flange)
<b>Maximum Axial Force</b>	10N

### Operation Environment Specifications

<b>Maximum Temperature Rise</b>	80°C
<b>Ambient Temperature</b>	-20°C to 50°C
<b>Ambient Humidity</b>	85% Max. (No Condensation)

## Protection Category

<b>IP Rating</b>	IP65; IP54
------------------	------------

## Approvals

<b>Compliance/Certifications</b>	CE / CSA / UL94-V0
<b>Standards Met</b>	NEMA-17, RoHS Compliant





### Characteristics

- Resistance Accuracy  $\pm 10\%$
- Inductance Accuracy  $\pm 20\%$
- Temperature Rise  $80^{\circ}\text{C}$  max. (rated current, 2 phase on)
- Ambient Temperature  $-10^{\circ}\text{C}$  to  $+50^{\circ}\text{C}$
- Insulation Resistance  $100\text{ M}\Omega$  min., 500 Vdc
- Dielectric Strength 500 Vac for one minute
- Shaft Radial Play 0.06 max. (450 g-load)
- Shaft Axial Play 0.08 max. (450 g-load)

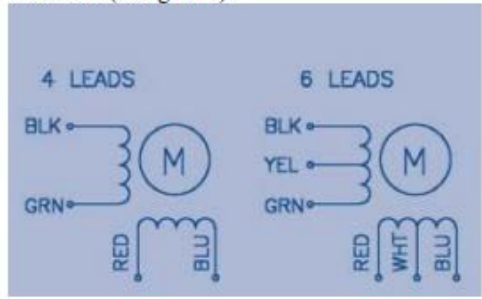

**DPM STEPPER MOTOR**

**42SH47**

**HIGH TORQUE HYBRID**

**42MM 1,8°**

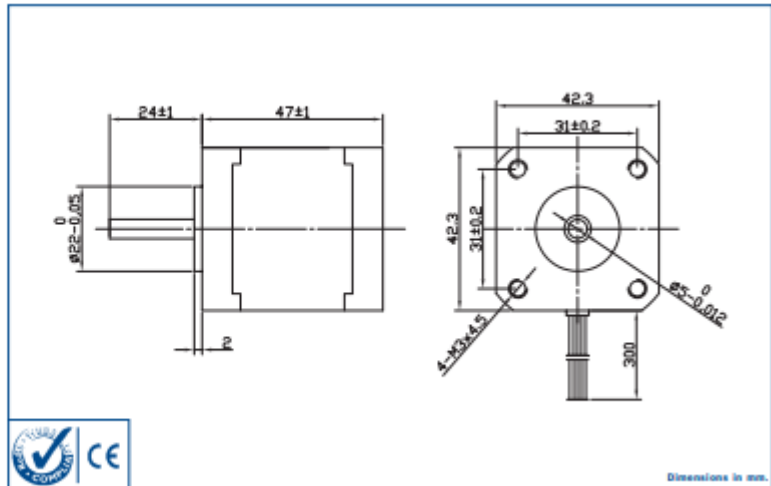

## Characteristics

<b>STEP ANGLE</b> 1,8°
<b>STEP ANGLE ACCURACY</b> ± 5%
<b>INSULATION CLASS</b> B
<b>AMBIENT TEMPERATURE</b> -20°C +50°C
<b>TEMP. RISE</b> 80°C MAX (RATED CURRENT, 2 PHASE ON)
<b>INSULATION RESISTANCE</b> 100 M OHM MIN. 500 VDC
<b>DIELECTRIC STRENGTH</b> 500 VAC FOR ONE MINUTE
<b>SHAFT RADIAL PLAY</b> 0,02 MAX (450 G LOAD)
<b>SHAFT AXIAL PLAY</b> 0,08 MAX. (450 G LOAD)
<b>MAX RADIAL FORCE</b> 28 N (20 MM FROM FRONT FLANGE)
<b>MAX AXIAL FORCE</b> 10 N

## Specifications

MODEL		42SH47-1A	42SH47-2A	42SH47-3A	42SH47-4A
1	RATED VOLTAGE V	4	6	12	2,8
2	CURRENT/PHASE A	1,2	0,8	0,4	1,68
3	RESISTANCE/PHASE Ω	3,3	7,5	30	1,65
4	INDUCTANCE/PHASE mH	2,8	6,3	25	2,8
5	HOLDING TORQUE Nm	0,317	0,317	0,317	0,44
6	ROTOR INERTIA g-cm <sup>2</sup>	68	68	68	68
7	WEIGHT Kg	0,35	0,35	0,35	0,35
8	NUMBER OF LEADS n°	6	6	6	4

## Speed vs. Torque Characteristics

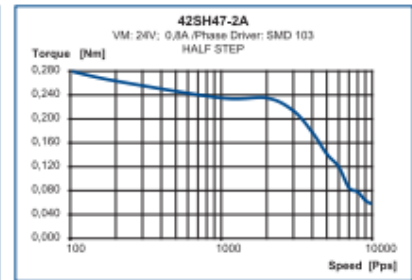
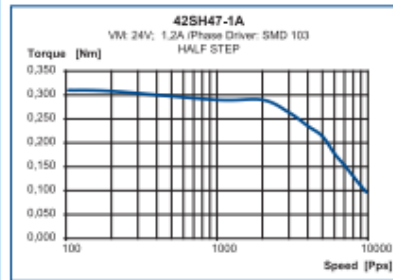

## Connection

LEAD N°	COLOR	GAUGE	FUNCTION
1	BLACK	UL1007 AWG24	PHASE A
2	GREEN	UL1007 AWG24	PHASE A-
3	RED	UL1007 AWG24	PHASE B
4	BLUE	UL1007 AWG24	PHASE B-
<b>UNIPOLAR MOTOR</b>			
5	YELLOW	UL1007 AWG24	COM PHASE A
6	WHITE	UL1007 AWG24	COM PHASE B

