

NUMBER GS-20-0568	TYPE Application Specification		
TITLE OBT Mounting Demounting		PAGE 1 of 20	REVISION D
		AUTHORIZED BY ALa	DATE 03/03/2020
		CLASSIFICATION Confidential	

1. Objective

This specification provides information and requirements regarding customer application of **mounting/unmounting an On-Board Transceiver (OBT)**. This specification is intended to provide general guidance for application process development. It is recognized that no single application process will work under all customer scenarios and that customers will develop their own application processes to meet their needs. However, if these application processes differ greatly from the one recommended, please contact AICC.

2. Content

1. OBJECTIVE	1
2. CONTENT	1
3. GENERAL	1
4. OBT AND SOCKET	2
5. TOOLS	3
6. UNPACKING THE OBT:.....	5
7. MOUNTING THE OBT	7
8. UNMOUNTING THE OBT	17

3. General

This application note covers the handling of the AICC On-Board Transceiver and the interposer. The unpacking, mounting and unmounting of the OBT are explained through detailed step by step instructions. The guidance is only valid for the AICC OBT **revision D** or higher. For older revision general handling guidance, please contact AICC.

NUMBER GS-20-0568	TYPE Application Specification		
TITLE OBT Mounting Demounting		PAGE 2 of 20	REVISION D
		AUTHORIZED BY ALa	DATE 03/03/2020
		CLASSIFICATION Confidential	

4. OBT and Interposer

The On-Board Transceiver is designed to be mounted on an AICC interposer using 4 screws. The Interposer itself is soldered on the PCB.

Onboard Transceiver
Part Number: 10124588-3YZ

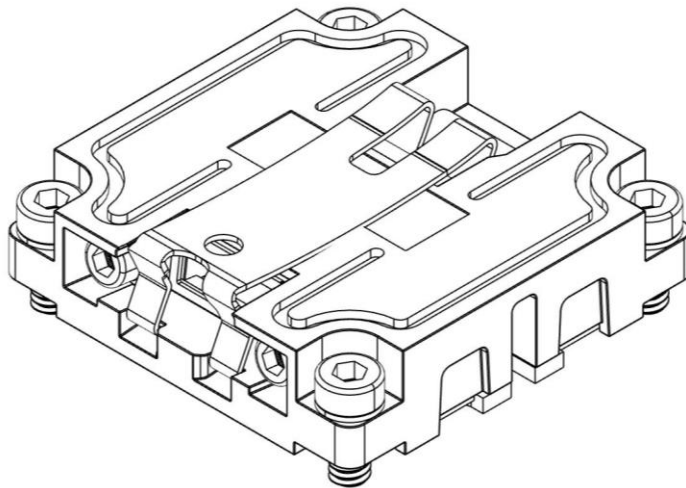

AICC Interposer
Part Number: 10140369-101LF

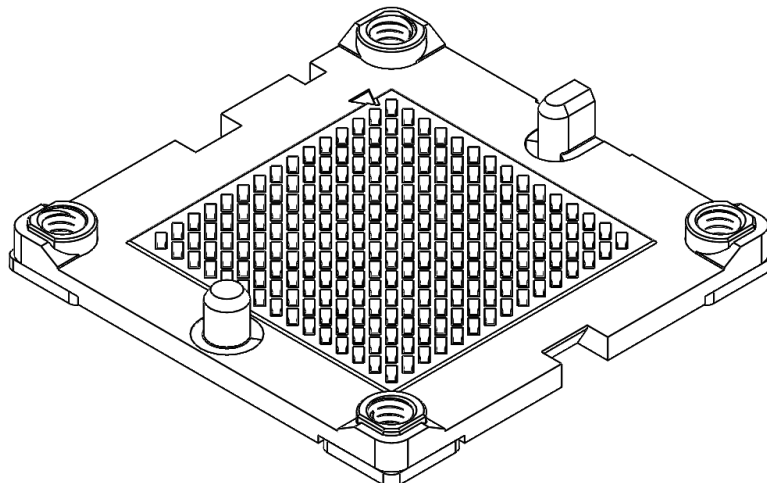

NUMBER GS-20-0568	TYPE Application Specification	Amphenol Active Optics Products	
TITLE OBT Mounting Demounting		PAGE 3 of 20	REVISION D
		AUTHORIZED BY ALa	DATE 03/03/2020
		CLASSIFICATION Confidential	

5. Tools

a. Overview:

Following tools are recommended to properly install the OBT:



1. Blade
2. Torque screwdriver (see 4.b for more details)
3. ESD metal or plastic tweezers
4. Fiber cleaner
5. Clip Assembly pliers (see 4.c for more details)

b. Torque screwdriver

The OBT has to be mounted on the interposer with a precise force to ensure on the one hand complete connections of all contact pins and on the other hand still not damage the socket or customer PCB. The precise force is ensured by a torque defined screwdriver.

- Requirements for torque screwdriver:

Defined torque	3.5	Ncm
Torque tolerance	± 10	%
ESD compliant	yes	
Hexagon	1.5	mm

NUMBER GS-20-0568	TYPE Application Specification	Amphenol Active Optics Products	
TITLE OBT Mounting Demounting		PAGE 4 of 20	REVISION D
		AUTHORIZED BY ALa	DATE 03/03/2020
		CLASSIFICATION Confidential	

- Recommended torque screwdrivers:

- Wera 1460 Kraffform Micro ESD pre-set adjustable torque screwdrivers
 - Product number: 0507480001
 - https://products.wera.de/en/torque_tools_series_7400_kraffform_torque_screwdrivers_pre-set_adjustable_torque_models_1460_micro_esd.html



- Wera Blade 840/9 C bits Hex-Plus
 - Product number: 05135268001
 - https://products.wera.de/en/bits_holders_adaptors_the_range_of_bits_bits_for_hexagon_socket_screws_840_9_c.html



c. Clip assembly pliers:

Customized pliers have been designed to facilitate the insertion and the removal of the MT ferrule clip. Please contact AICC for more information on how to order this tool.



NUMBER GS-20-0568	TYPE Application Specification	Amphenol Active Optics Products	
TITLE OBT Mounting Demounting		PAGE 5 of 20	REVISION D
		AUTHORIZED BY ALa	DATE 03/03/2020
		CLASSIFICATION Confidential	

6. Unpacking the OBT:

Step 1

Cut the ESD label and remove the ESD blister from the sleeve



Step 2

Open the blister after having cut the ESD label:



NUMBER GS-20-0568	TYPE Application Specification		
TITLE OBT Mounting Demounting		PAGE 6 of 20	REVISION D
		AUTHORIZED BY ALa	DATE 03/03/2020
CLASSIFICATION Confidential			

Step 3

Remove the OBT and clip from the blister:

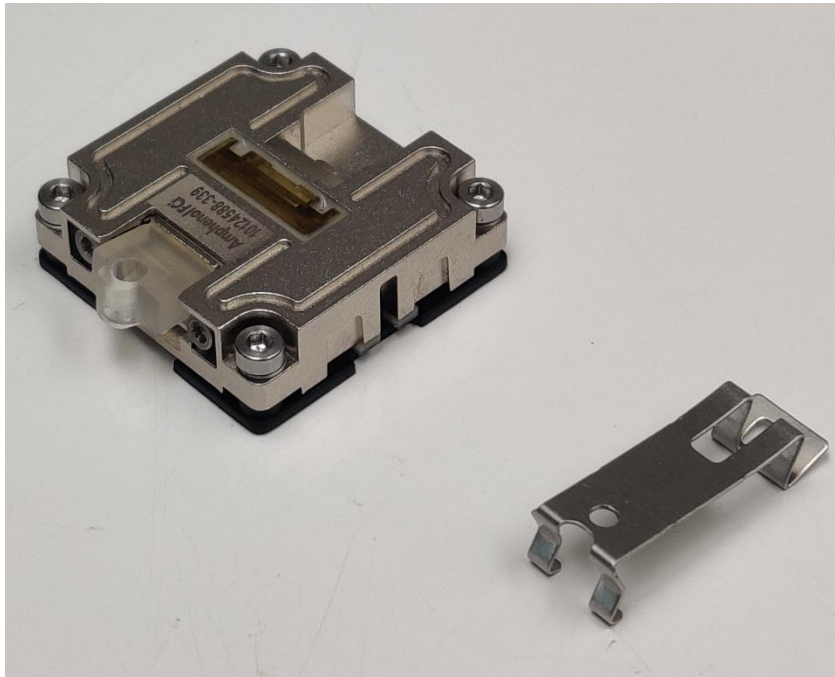

Step 4

Remove transport cap by unscrewing all 4 screws using the recommended torque screwdriver:

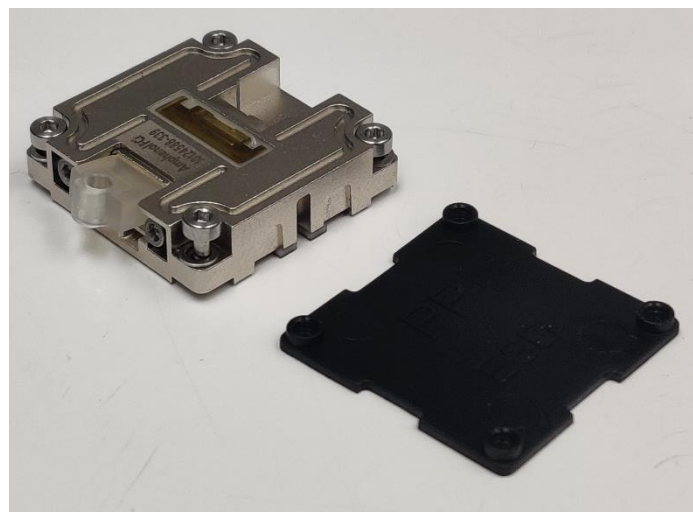

NUMBER GS-20-0568	TYPE Application Specification		
TITLE OBT Mounting Demounting		PAGE 7 of 20	REVISION D
		AUTHORIZED BY ALa	DATE 03/03/2020
CLASSIFICATION Confidential			

7. Mounting the OBT

Handle the OBT only in an electrostatic protected area (EPA) to avoid damaging electrostatic discharge (ESD).

Start

AFCI socket is soldered on a PCB (Example is OBT evaluation board)

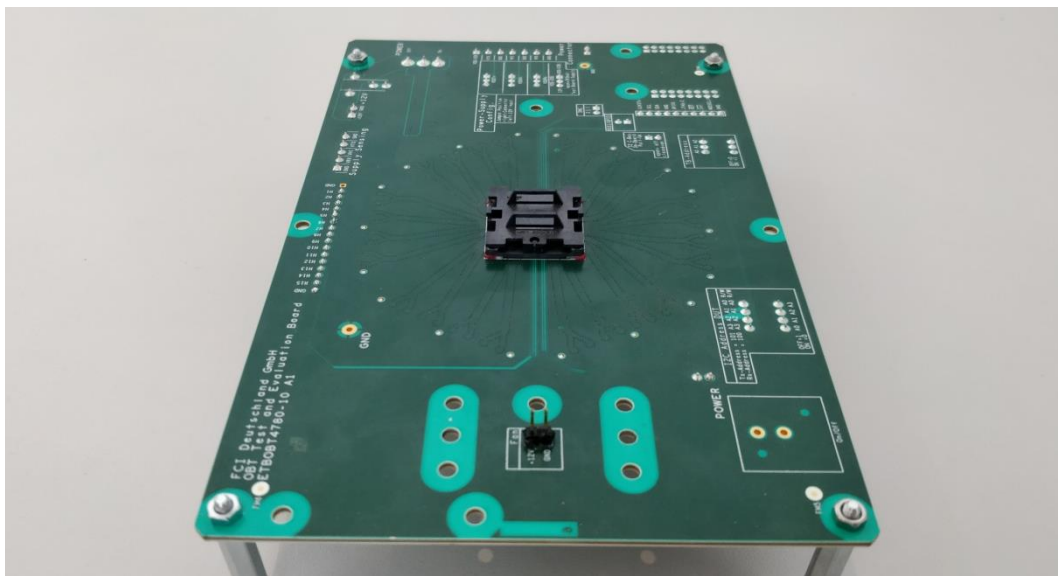

Step 1

Remove the protection cap of the socket by pressing the left and right plastic pins together and lift up the cap.

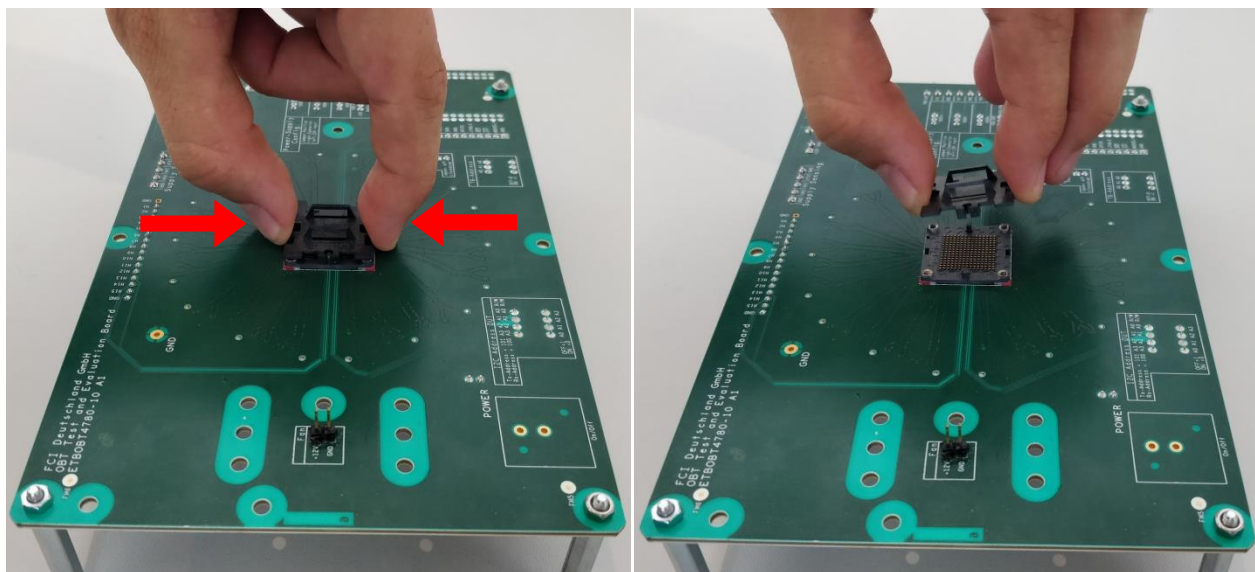

NUMBER GS-20-0568	TYPE Application Specification	Amphenol Active Optics Products	
TITLE OBT Mounting Demounting		PAGE 8 of 20	REVISION D
		AUTHORIZED BY ALa	DATE 03/03/2020
		CLASSIFICATION Confidential	

Step 2

Check the socket of damage pins and clean the socket with dry air of dust. Recommendation is to look form two different perspectives on the socket to recognize damaged pins.

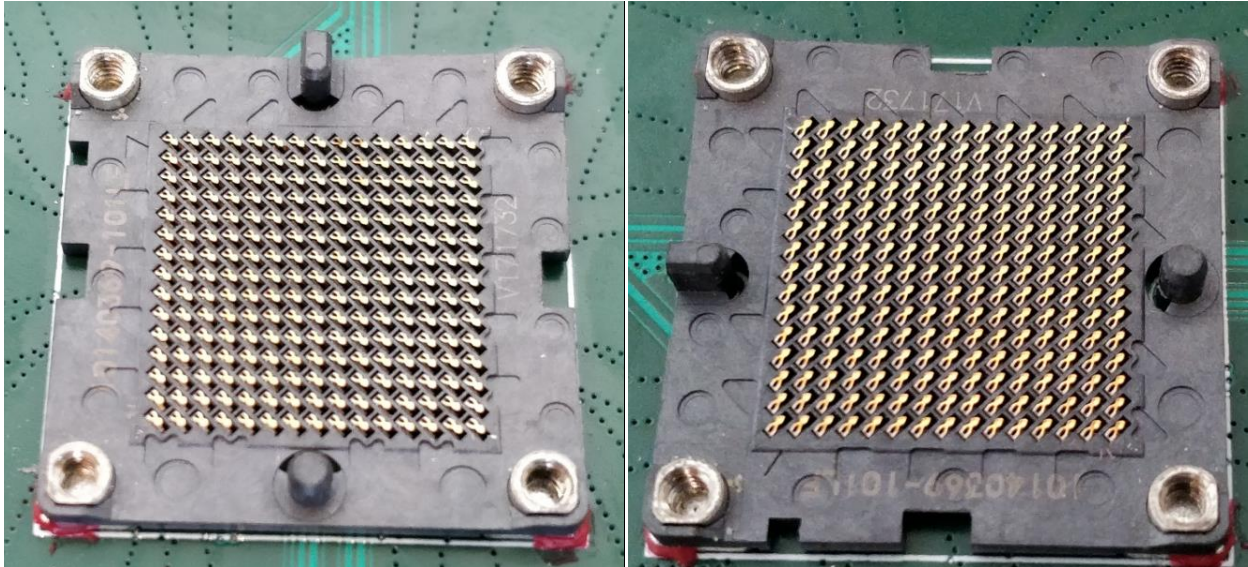

Step 3

Take a OBT clean the contact pads with dry air and put it in the right direction on the socket.

Do not remove the dust cap of the OBT yet.

The OBT lays now on the contact pins and there is a cap between the OBT and socket at the corners.

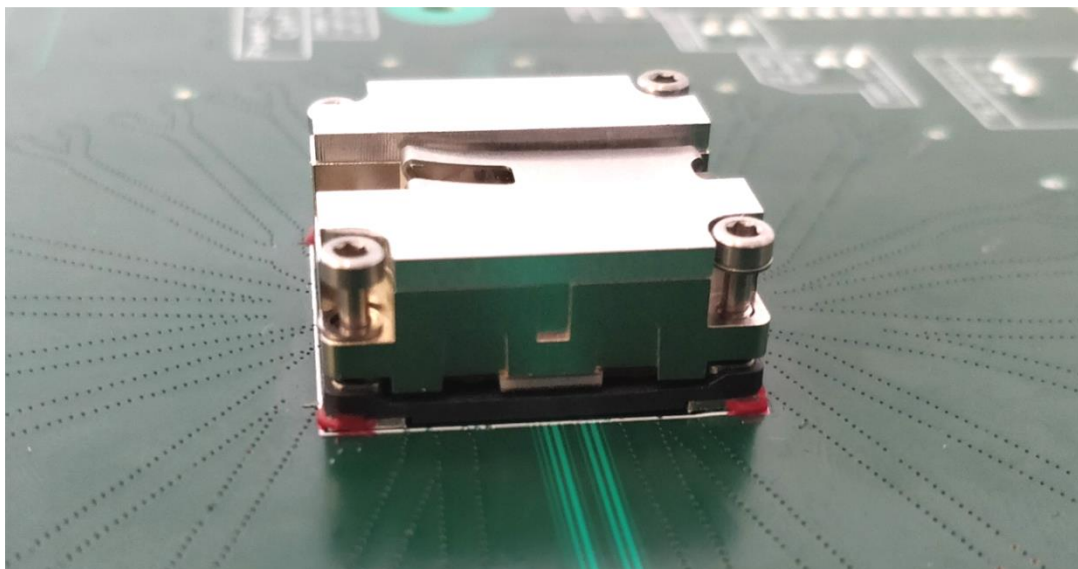

NUMBER GS-20-0568	TYPE Application Specification	Amphenol Active Optics Products	
TITLE OBT Mounting Demounting		PAGE 9 of 20	REVISION D
		AUTHORIZED BY ALa	DATE 03/03/2020
		CLASSIFICATION Confidential	

Step 4

Hold down the OBT on the socket with two fingers during the mounting or demounting process.
 Press with no strong forced down.
 Hold it to check during the next steps that the OBT do not angle to one side when screws are tighten.

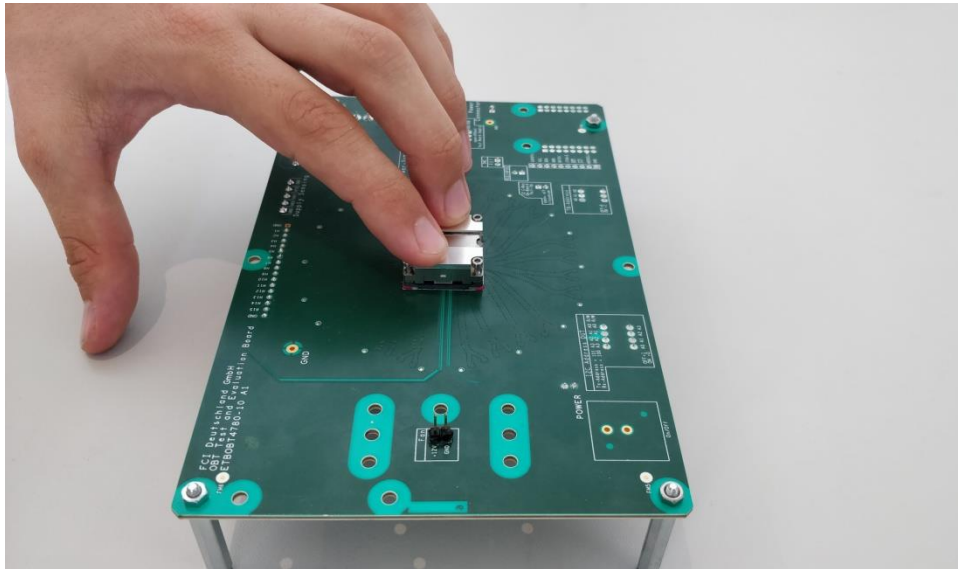

Step 5 (a)

Screw down a screw just to the point where the screw joins the thread. Best way to find that point is to screw one rotation right and then backward till the screw snap in the start of the thread.

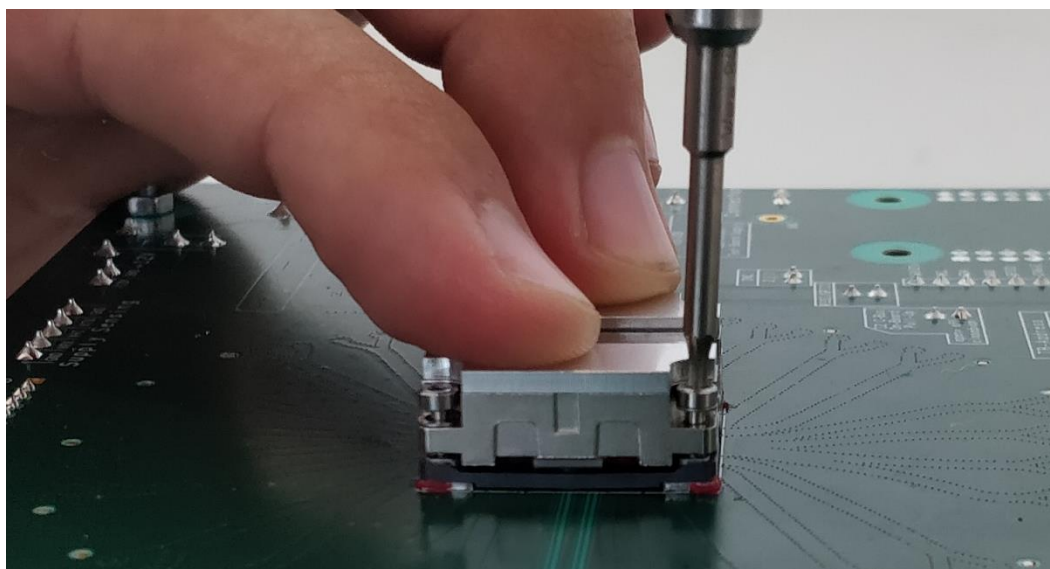

NUMBER GS-20-0568	TYPE Application Specification	Amphenol Active Optics Products	
TITLE OBT Mounting Demounting		PAGE 10 of 20	REVISION D
		AUTHORIZED BY ALa	DATE 03/03/2020
		CLASSIFICATION Confidential	

Step 5 (b)

Start by the point of Step 5 (a) screw the screw 3 turns down.
As indicate the label on the screwdriver can be used.

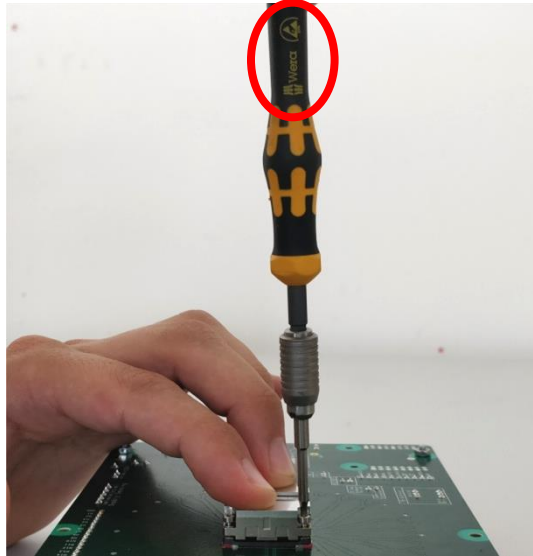

Informative:

Pictures of 0 rotation (start point), 1 rotation, 2 rotations and 3 rotations

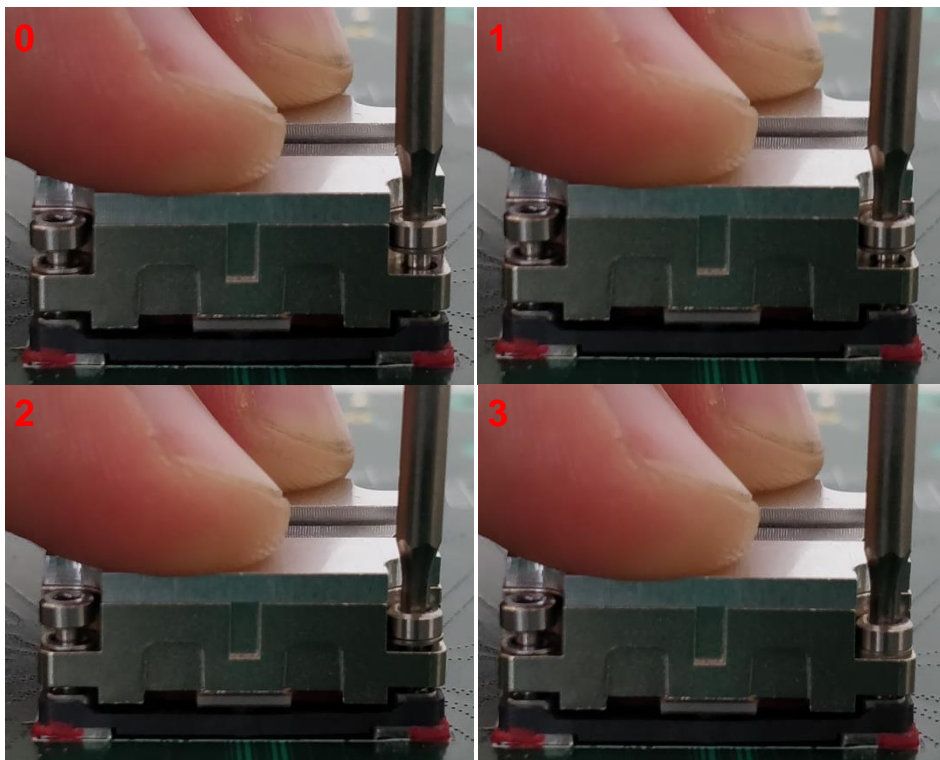

NUMBER GS-20-0568	TYPE Application Specification	Amphenol Active Optics Products	
TITLE OBT Mounting Demounting		PAGE 11 of 20	REVISION D
		AUTHORIZED BY ALa	DATE 03/03/2020
		CLASSIFICATION Confidential	

Repeat Step 5 (a) and (b) with the other screws.
Follow the sequence described on the picture below.

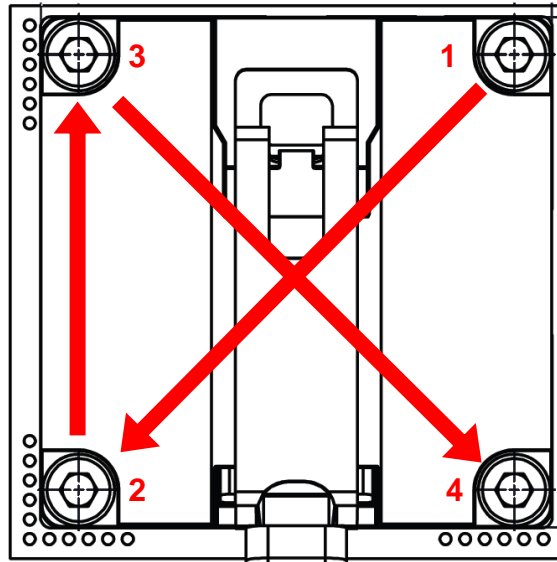

Step 6

Screw fix all screws with the defined torque of 3.5 Ncm.

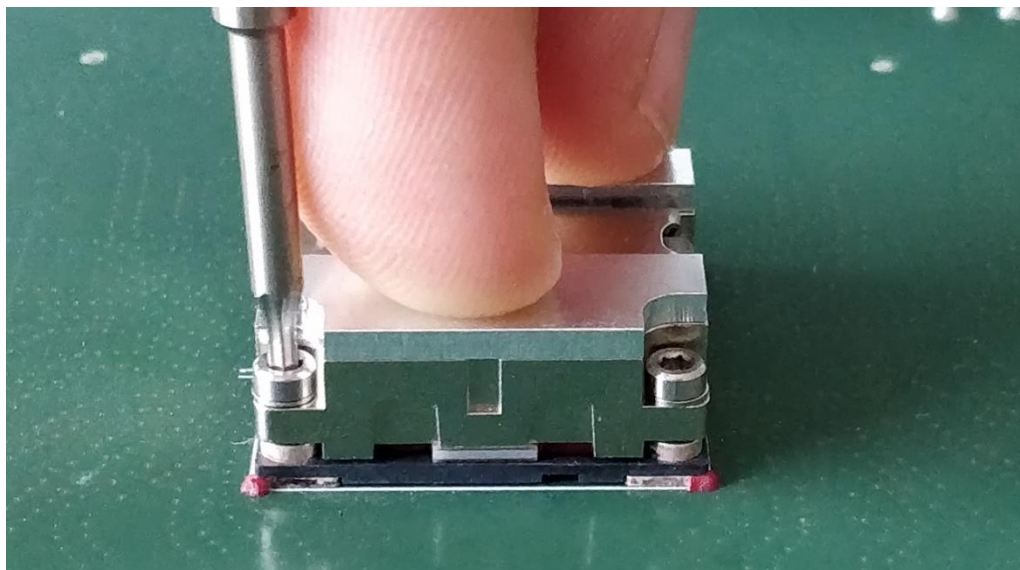

NUMBER GS-20-0568	TYPE Application Specification		
TITLE OBT Mounting Demounting		PAGE 12 of 20	REVISION D
		AUTHORIZED BY ALa	DATE 03/03/2020
		CLASSIFICATION Confidential	

Step 7

Check the corners of the socket for damage.

Undamaged socket corners:

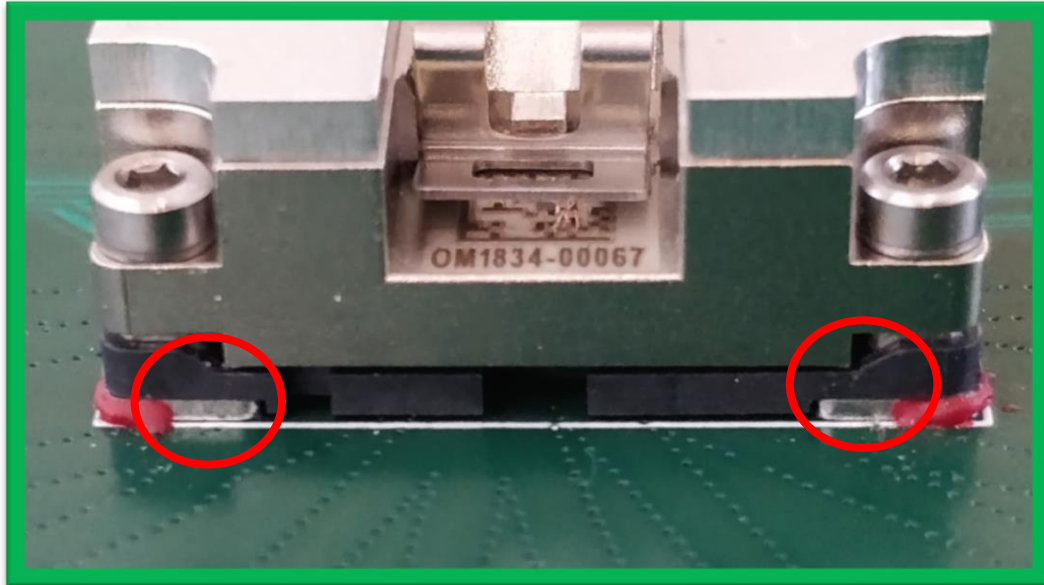

Damaged socket corners:

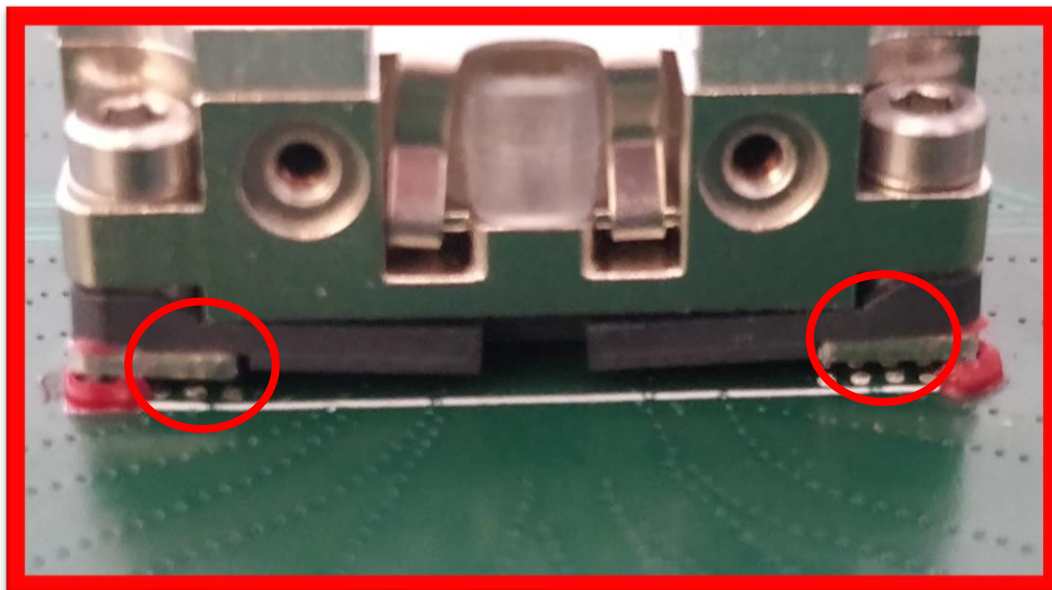

NUMBER GS-20-0568	TYPE Application Specification		
TITLE OBT Mounting Demounting		PAGE 13 of 20	REVISION D
		AUTHORIZED BY ALa	DATE 03/03/2020
		CLASSIFICATION Confidential	

Step 8

Use tweezers to pull out the OBT dust cap and then clean carefully the optical interface of the OBT with dust air

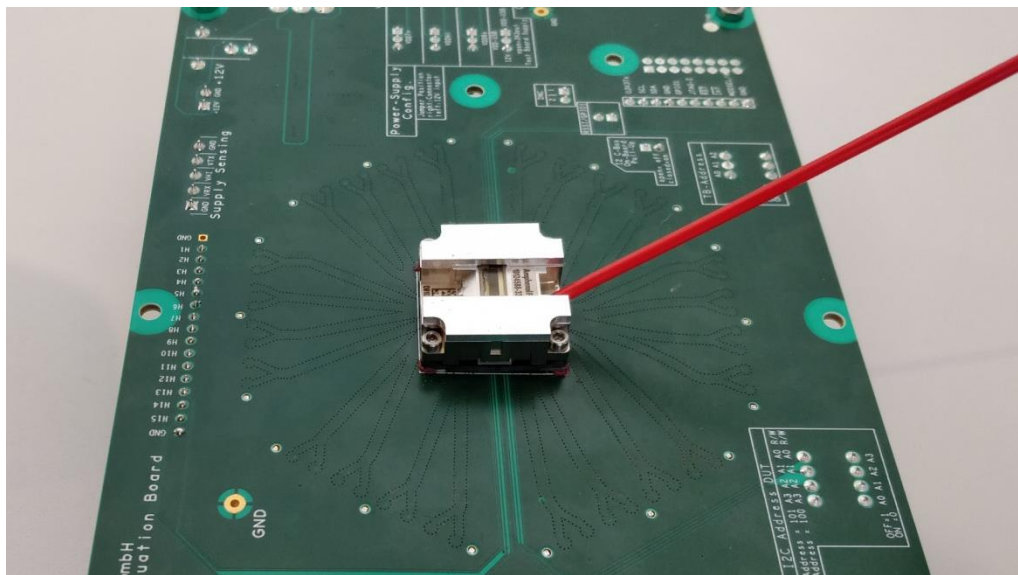
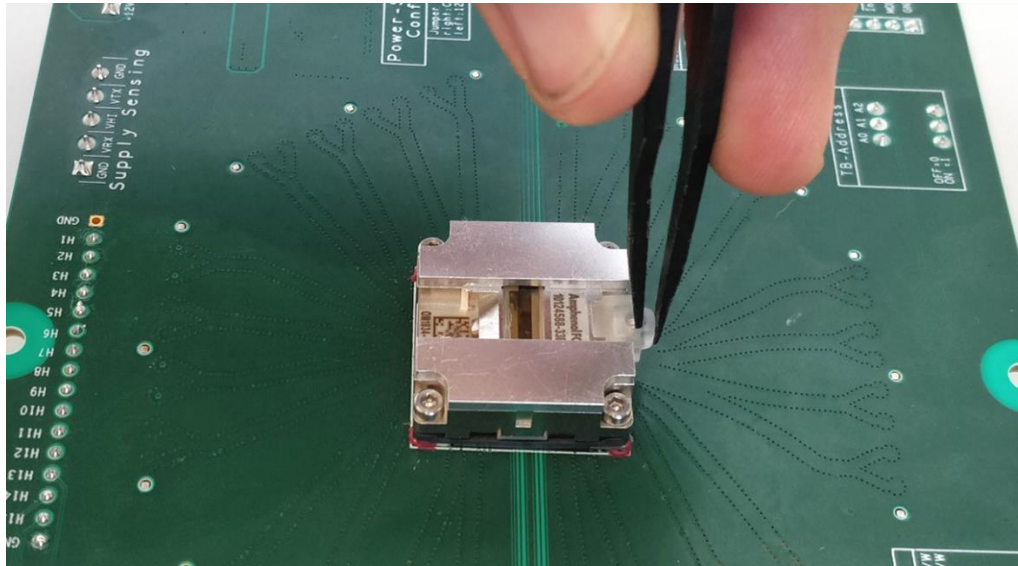

NUMBER GS-20-0568	TYPE Application Specification		
TITLE OBT Mounting Demounting		PAGE 14 of 20	REVISION D
		AUTHORIZED BY ALa	DATE 03/03/2020
		CLASSIFICATION Confidential	

Step 9

Clean the MT ferrule of the fiber with an appropriated cleaning tool.



Step 10

Insert the MT ferrule into the optical interface of the OBT.

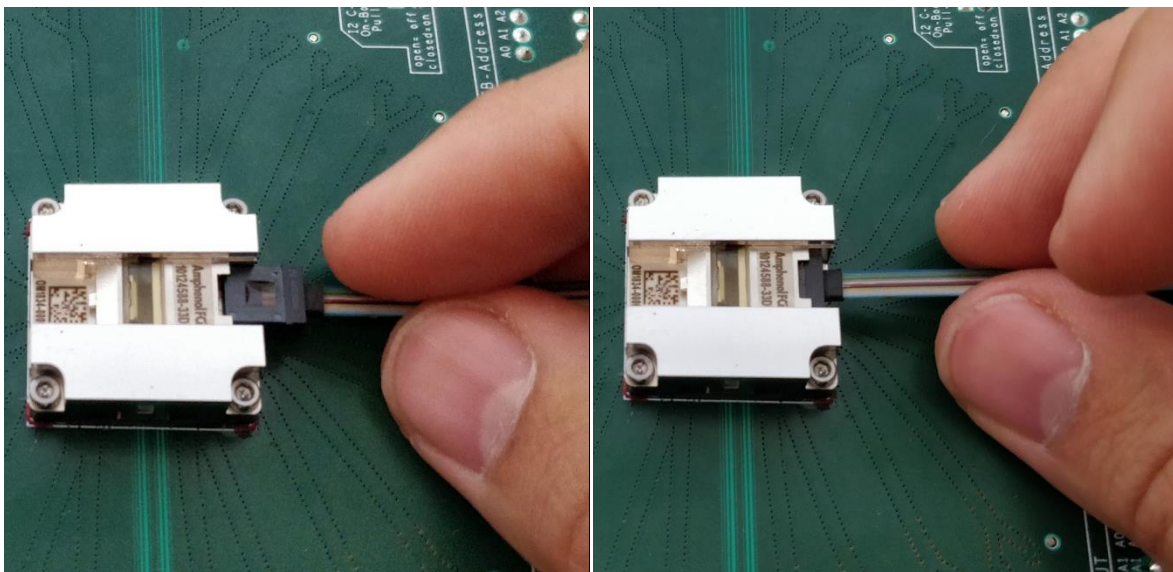

NUMBER GS-20-0568	TYPE Application Specification		
TITLE OBT Mounting Demounting		PAGE 15 of 20	REVISION D
		AUTHORIZED BY ALa	DATE 03/03/2020
		CLASSIFICATION Confidential	

Step 11

Pick the MT ferrule clip using the Clip Assembly pliers as shown below:

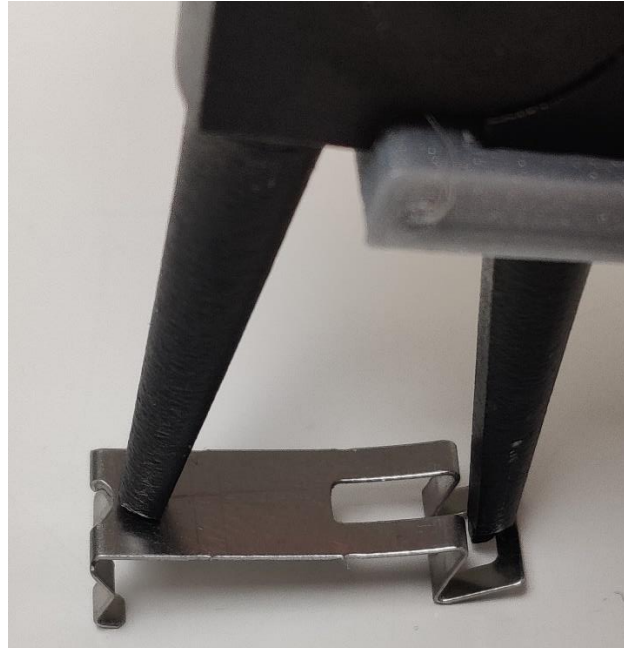

Step 12

Start assembling the clip by sliding it over the MT ferrule rubber boot as shown. Make sure both clip fingers are correctly inserted in the dedicated holes (red circles):

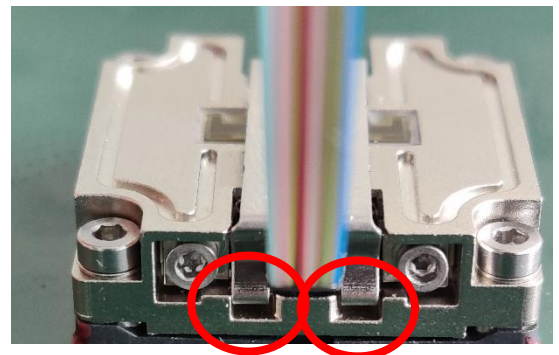
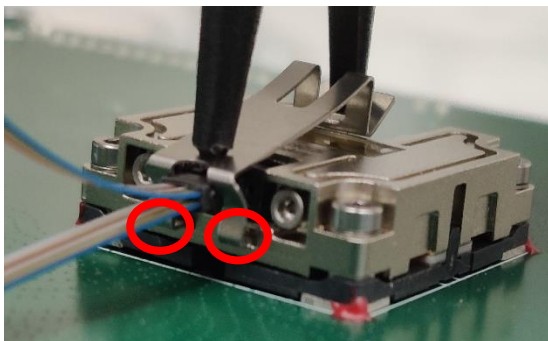

NUMBER GS-20-0568	TYPE Application Specification	Amphenol Active Optics Products	
TITLE OBT Mounting Demounting		PAGE 16 of 20	REVISION D
		AUTHORIZED BY ALa	DATE 03/03/2020
		CLASSIFICATION Confidential	

Step 13

Tighten the pliers to overbend the clip and push down the z-shape side of the clip.
Release the pliers for the clip to snap in:

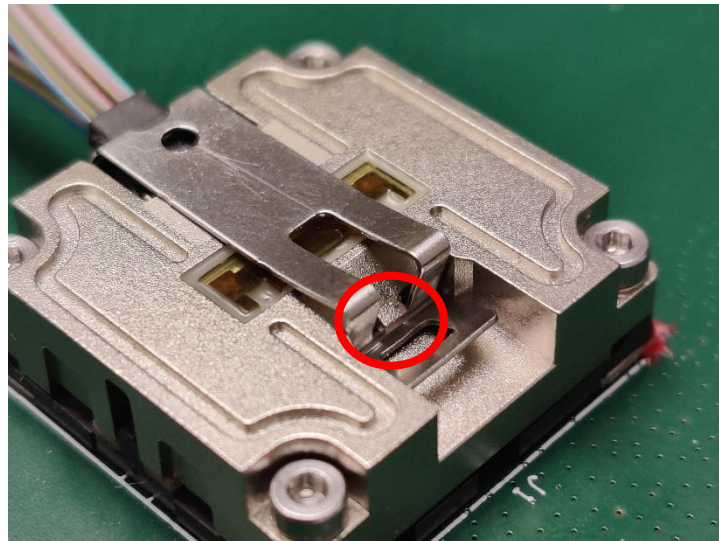
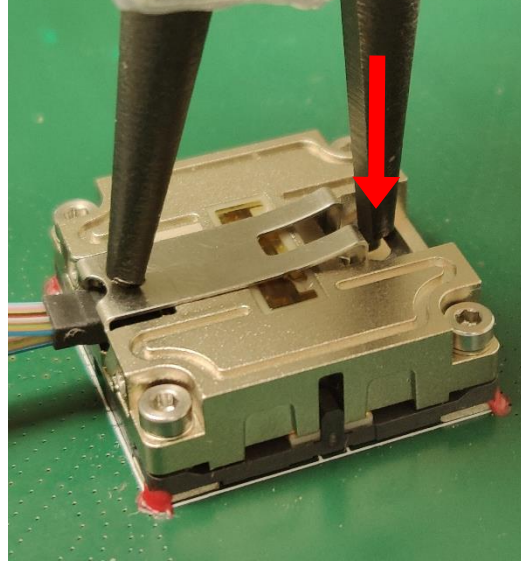
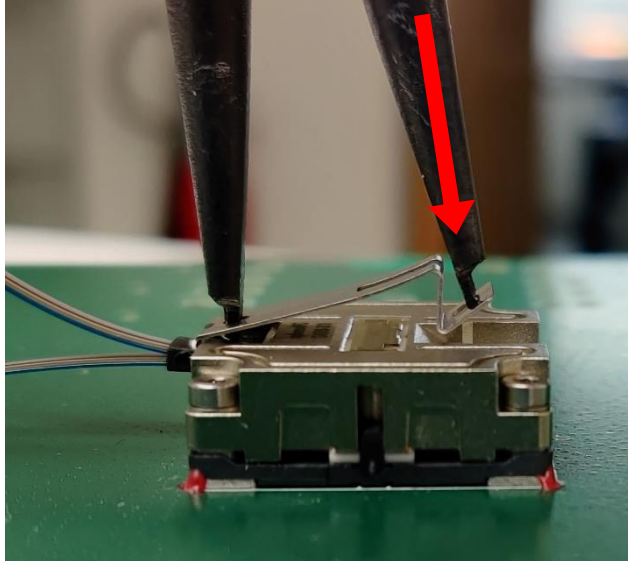

NUMBER GS-20-0568	TYPE Application Specification	Amphenol Active Optics Products	
TITLE OBT Mounting Demounting		PAGE 17 of 20	REVISION D
		AUTHORIZED BY ALa	DATE 03/03/2020
		CLASSIFICATION Confidential	

8. Unmounting the OBT

Step 1

Insert the Clip Assembly pliers as shown and tighten the pliers to overbend the clip (picture 1).
Release the z shaped part of the clip by lifting the side of the pliers holding the z shaped part of the clip (picture 2).

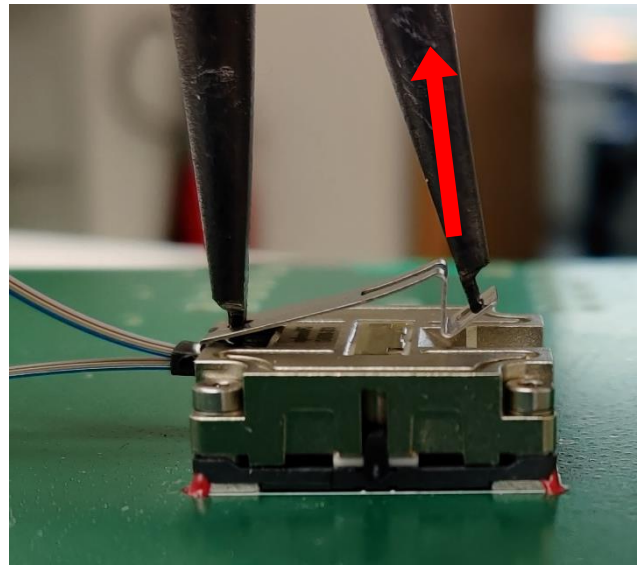
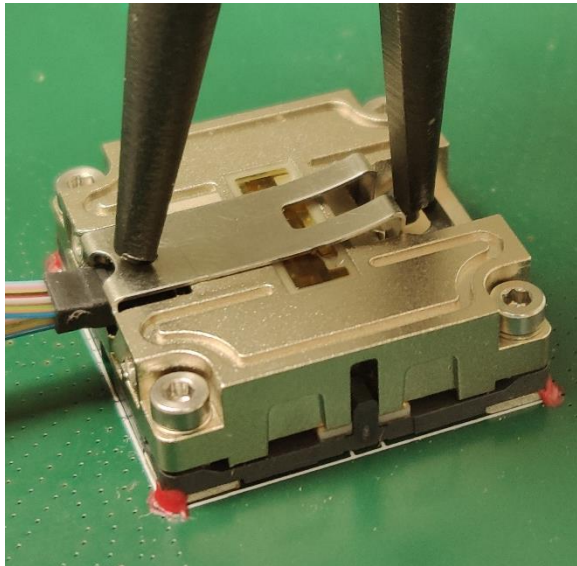

Step 2

Release the Clip Assembly pliers and carefully disassemble the clip by sliding it over the MT ferrule rubber boot. Finally lift the pliers to fully remove the clip.

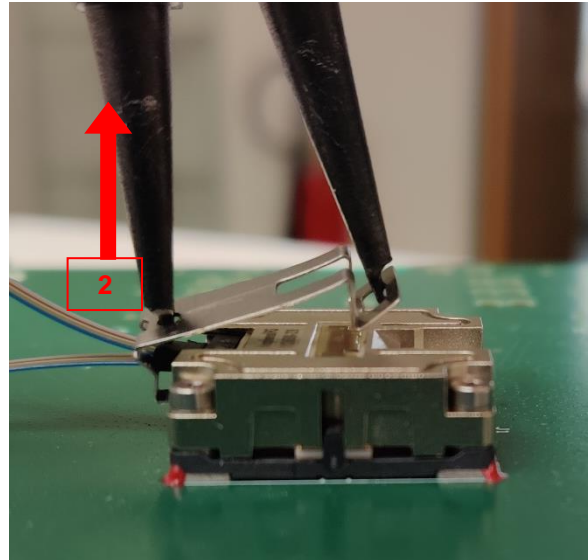
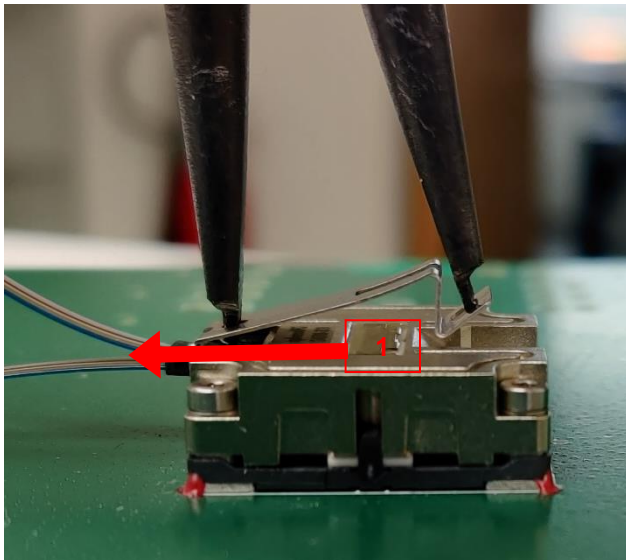

NUMBER GS-20-0568	TYPE Application Specification		
TITLE OBT Mounting Demounting		PAGE 18 of 20	REVISION D
		AUTHORIZED BY ALa	DATE 03/03/2020
		CLASSIFICATION Confidential	

Step 3

Remove the fiber and plug the dust cap.

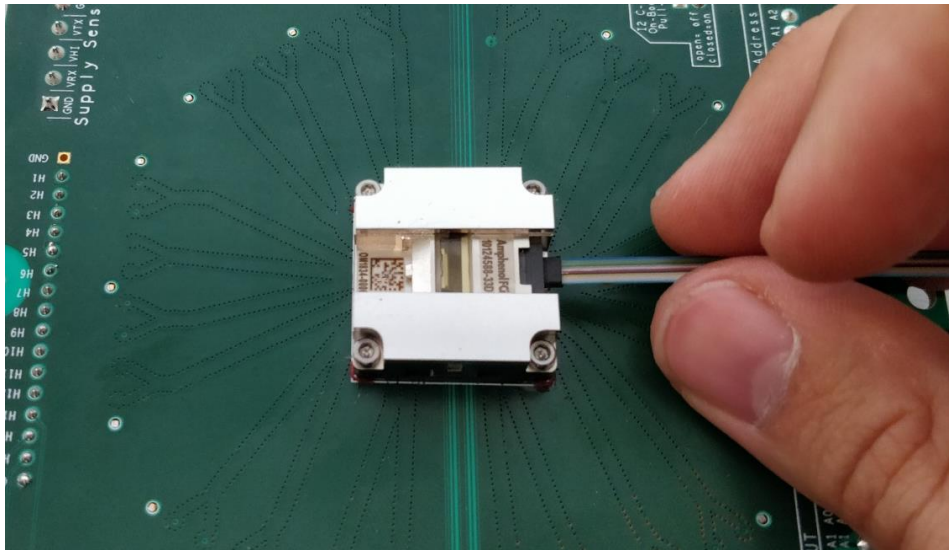

Step 4

Hold down the OBT with two fingers.

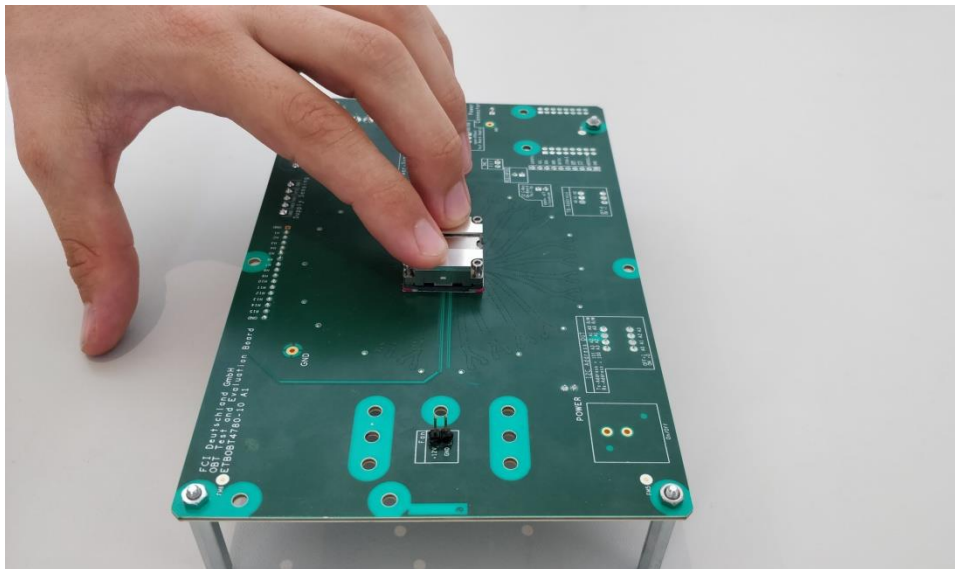

NUMBER GS-20-0568	TYPE Application Specification		
TITLE OBT Mounting Demounting		PAGE 19 of 20	REVISION D
		AUTHORIZED BY ALa	DATE 03/03/2020
		CLASSIFICATION Confidential	

Step 5

Unscrew all screw following similar cross pattern as for the mounting process.

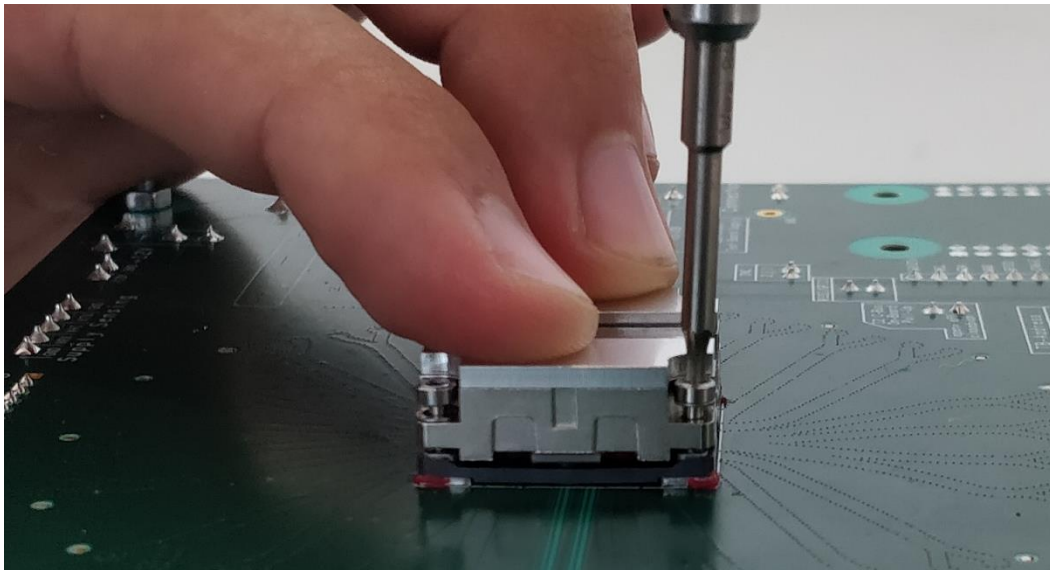

Step 6

Take off the OBT.

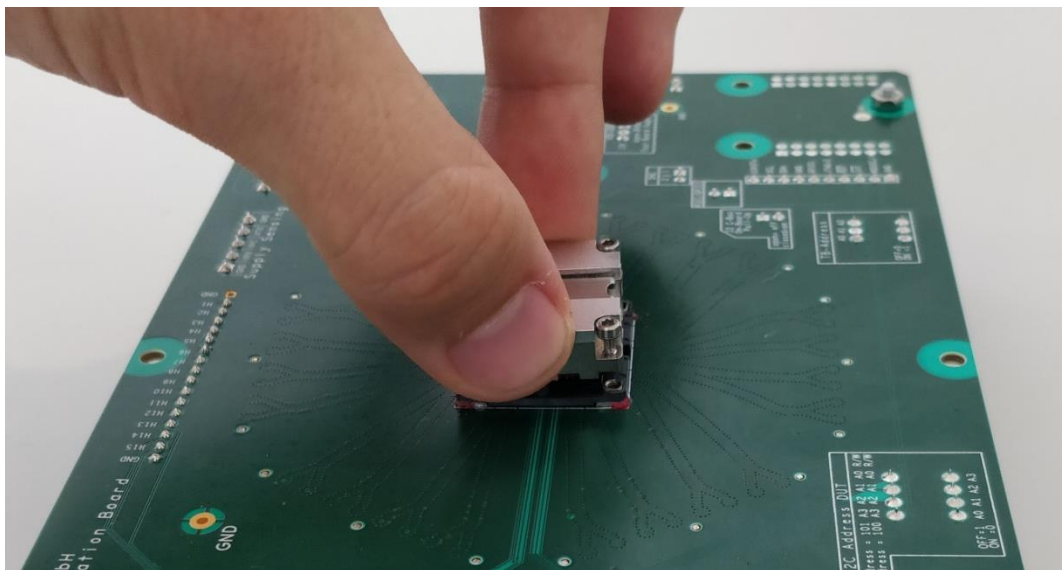

NUMBER GS-20-0568	TYPE Application Specification		
TITLE OBT Mounting Demounting		PAGE 20 of 20	REVISION D
		AUTHORIZED BY ALa	DATE 03/03/2020
		CLASSIFICATION Confidential	

Step 7

Attach the OBT on the transport cap by tightening all 4 screws with the recommended screwdriver.

