

VinMin = 5.0V
 VinMax = 5.0V
 Vout = 1.8V
 Iout = 6.0A

Device = TPSM5D1806RDBR
 Topology = Buck
 Created = 2023-09-06 17:53:21.038
 BOM Cost = \$18.80
 BOM Count = 23
 Total Pd = 3.6W

WEBENCH[®] Design Report

Design : 7 TPSM5D1806RDBR
 TPSM5D1806RDBR 5V-5V to 1.80V @ 6A

Vout = 1.8V
 Iout = 6.0A

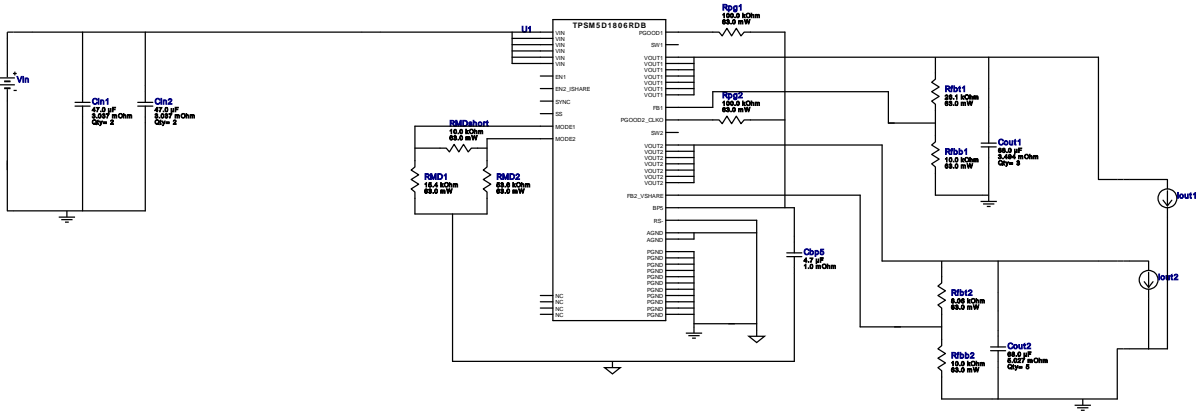

Electrical BOM

Name	Manufacturer	Part Number	Properties	Qty	Price	Footprint
Cbp5	MuRata	GRM155R61A475MEAAD Series= X5R	Cap= 4.7 uF ESR= 1.0 mOhm VDC= 10.0 V IRMS= 0.0 A	1	\$0.02	0402_065 3 mm ²
Cin1	MuRata	GRM32ER61C476KE15L Series= X5R	Cap= 47.0 uF ESR= 3.037 mOhm VDC= 16.0 V IRMS= 4.59346 A	2	\$0.17	1210_280 15 mm ²
Cin2	MuRata	GRM32ER61C476KE15L Series= X5R	Cap= 47.0 uF ESR= 3.037 mOhm VDC= 16.0 V IRMS= 4.59346 A	2	\$0.17	1210_280 15 mm ²
Cout1	TDK	C3216X5R1A686M160AC Series= X5R	Cap= 68.0 uF ESR= 3.494 mOhm VDC= 10.0 V IRMS= 3.8813 A	3	\$0.47	1206_190 11 mm ²
Cout2	TDK	C4532X5R0J686M280KA Series= X5R	Cap= 68.0 uF ESR= 5.027 mOhm VDC= 6.3 V IRMS= 3.4212 A	5	\$0.92	1812_320 23 mm ²
RMD1	Yageo	AC0402FR-0715K4L Series= ?	Res= 15.4 kOhm Power= 63.0 mW Tolerance= 1.0%	1	\$0.01	0402 3 mm ²
RMD2	Vishay-Dale	CRCW040253K6FKED Series= CRCW..e3	Res= 53.6 kOhm Power= 63.0 mW Tolerance= 1.0%	1	\$0.01	0402 3 mm ²
RMDshort	Vishay-Dale	CRCW040210K0FKED Series= CRCW..e3	Res= 10.0 kOhm Power= 63.0 mW Tolerance= 1.0%	1	\$0.01	0402 3 mm ²
Rfb1	Vishay-Dale	CRCW040210K0FKED Series= CRCW..e3	Res= 10.0 kOhm Power= 63.0 mW Tolerance= 1.0%	1	\$0.01	0402 3 mm ²

Name	Manufacturer	Part Number	Properties	Qty	Price	Footprint
Rfbb2	Vishay-Dale	CRCW040210K0FKED Series= CRCW..e3	Res= 10.0 kOhm Power= 63.0 mW Tolerance= 1.0%	1	\$0.01	0402 3 mm ²
Rfbb1	Vishay-Dale	CRCW040226K1FKED Series= CRCW..e3	Res= 26.1 kOhm Power= 63.0 mW Tolerance= 1.0%	1	\$0.01	0402 3 mm ²
Rfbb2	Vishay-Dale	CRCW04028K06FKED Series= CRCW..e3	Res= 8.06 kOhm Power= 63.0 mW Tolerance= 1.0%	1	\$0.01	0402 3 mm ²
Rpg1	Vishay-Dale	CRCW0402100KFKED Series= CRCW..e3	Res= 100.0 kOhm Power= 63.0 mW Tolerance= 1.0%	1	\$0.01	0402 3 mm ²
Rpg2	Vishay-Dale	CRCW0402100KFKED Series= CRCW..e3	Res= 100.0 kOhm Power= 63.0 mW Tolerance= 1.0%	1	\$0.01	0402 3 mm ²
U1	Texas Instruments	TPSM5D1806RDBR	Switcher	1	\$12.00	RPB0025A 35 mm ²

SW2 Ipk

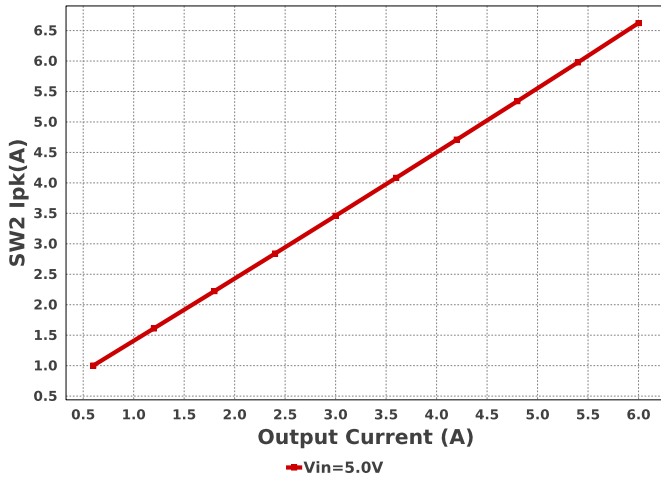

IC Tj

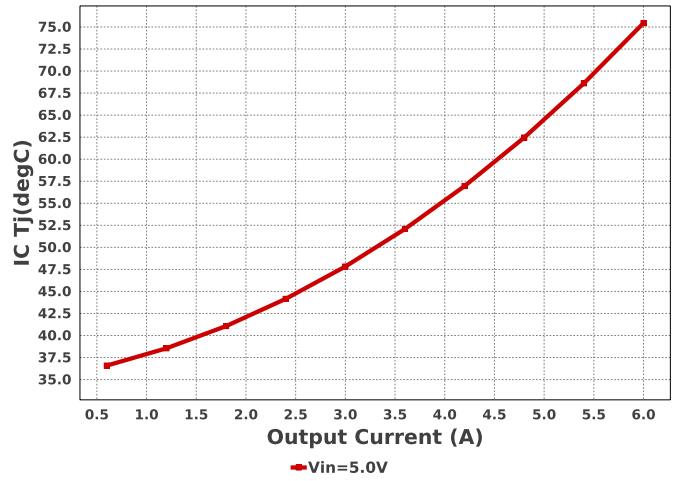

Cin1 IRMS

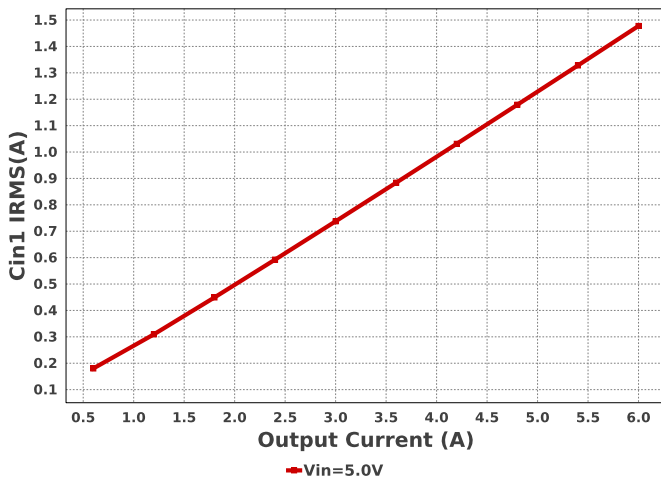

Cout_ch1 IRMS

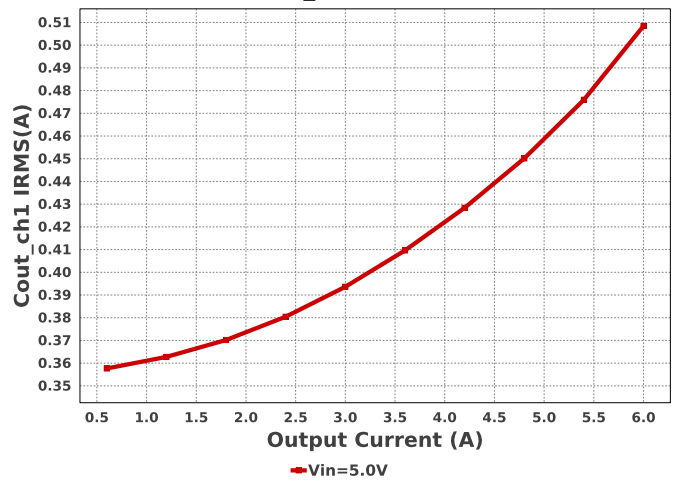

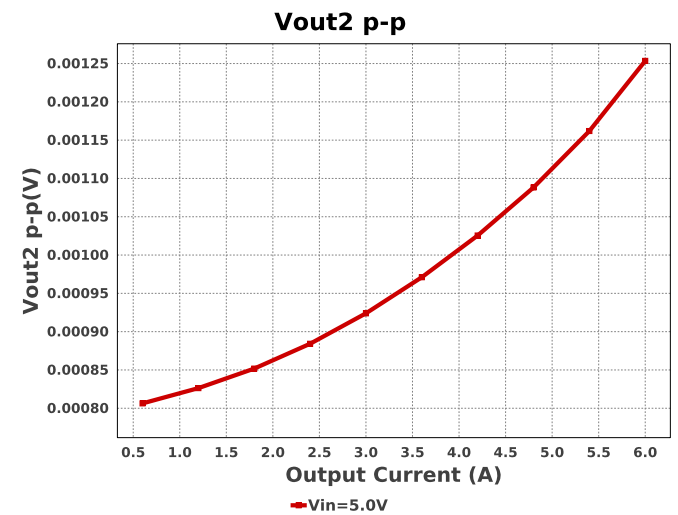
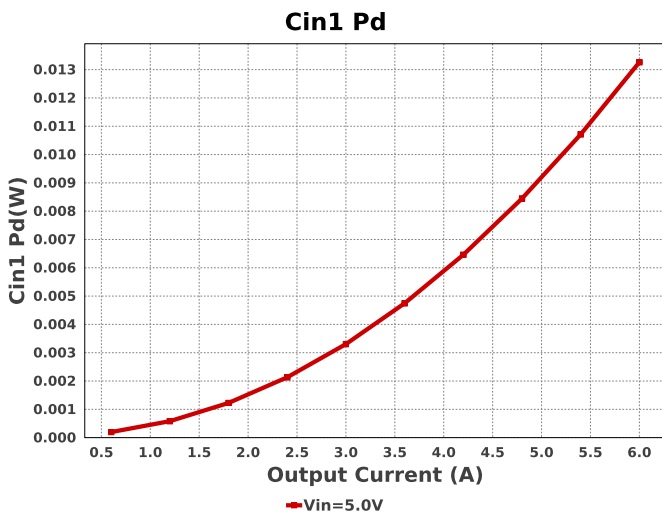
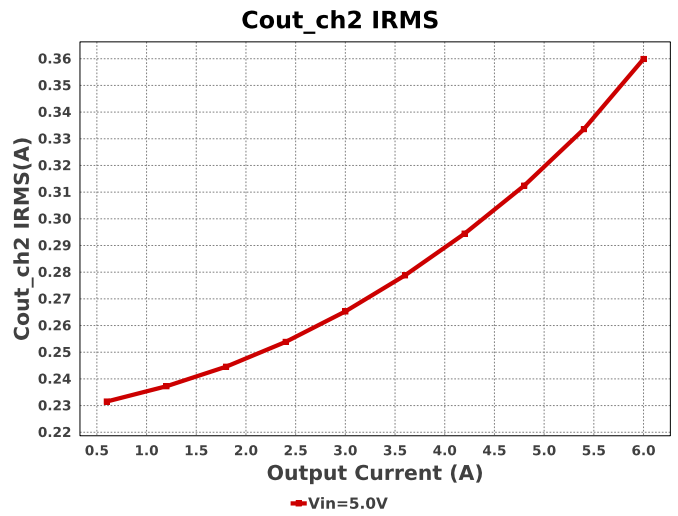
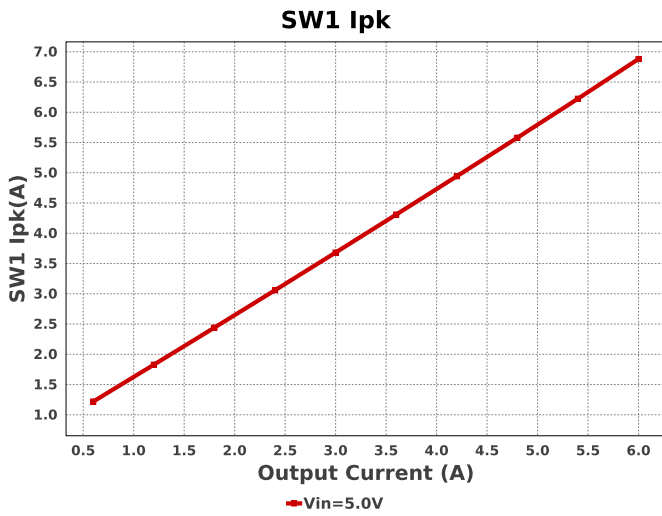
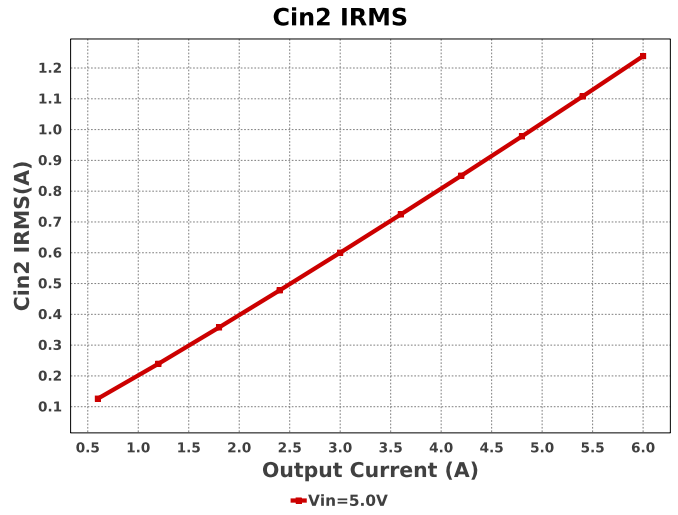
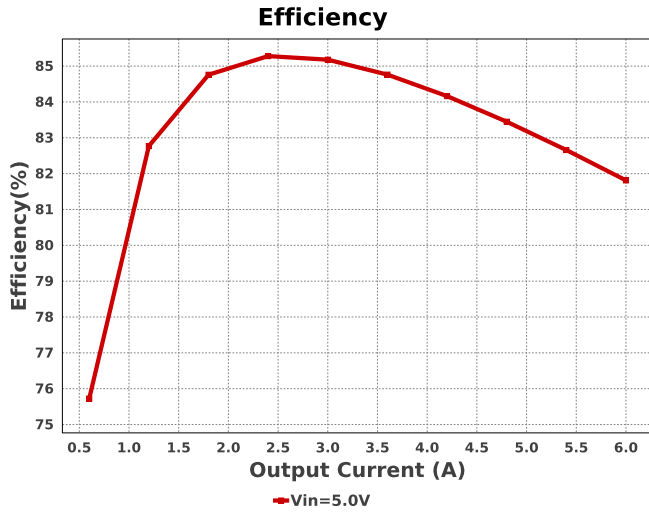

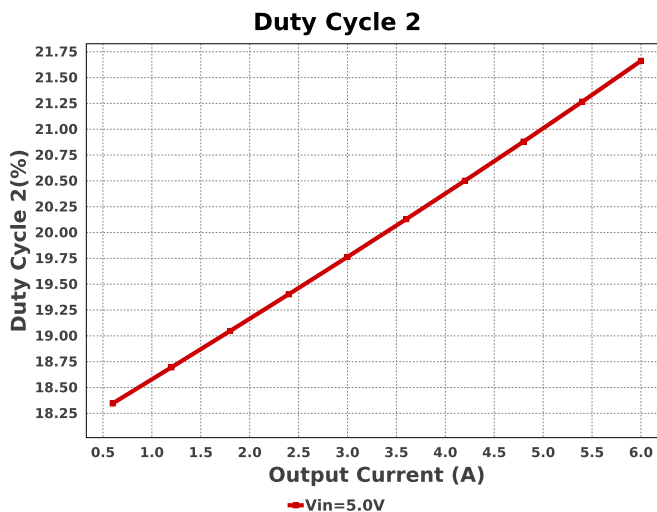
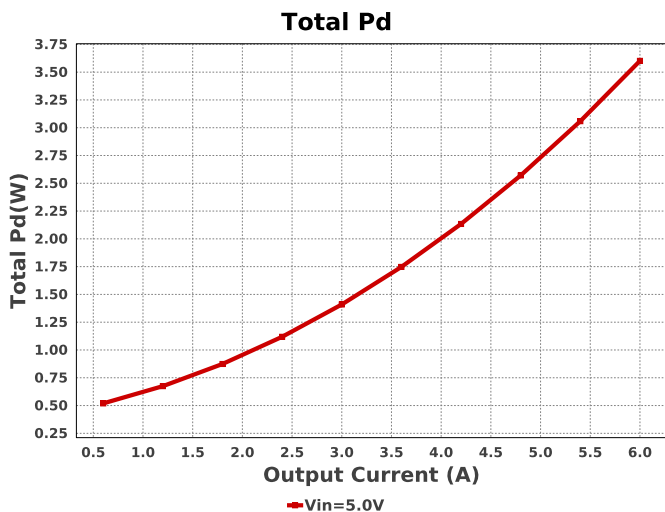
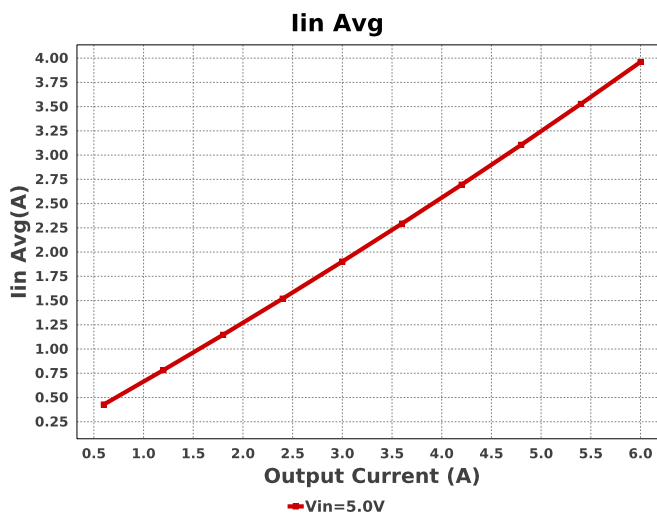
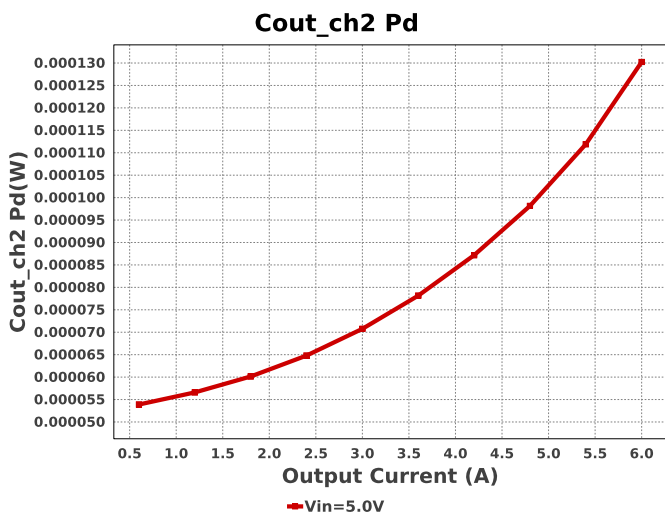
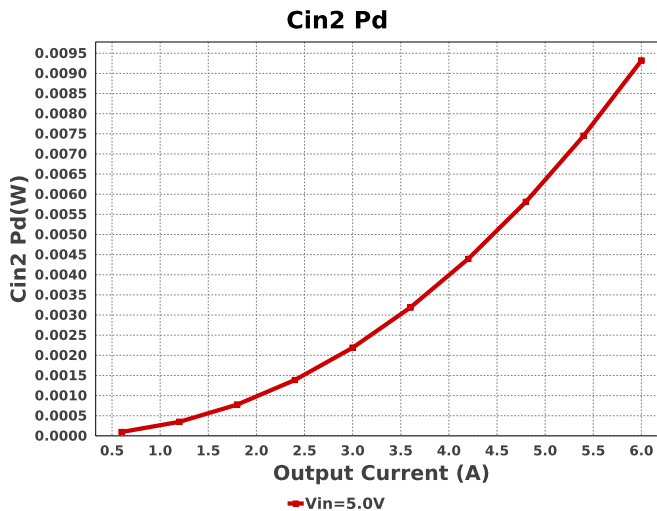
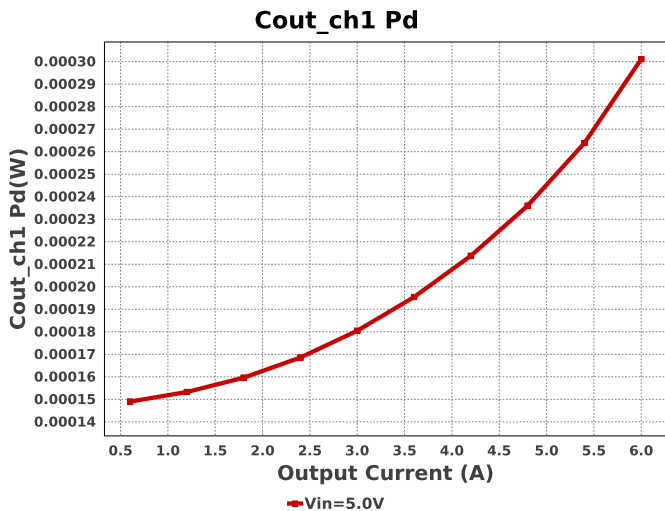

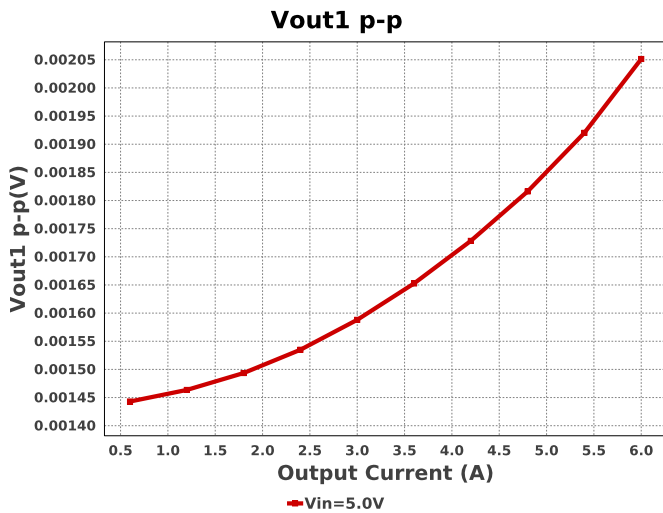
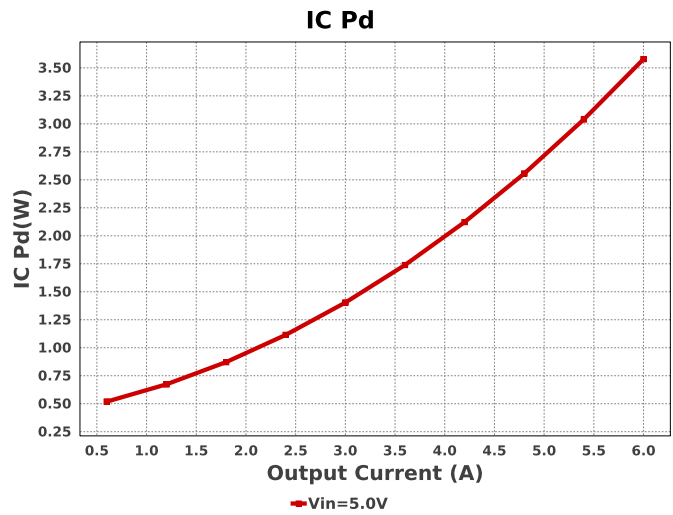
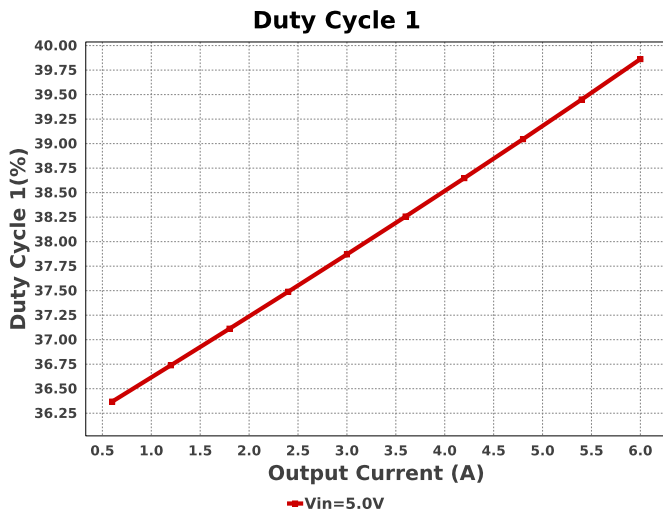

Operating Values

#	Name	Value	Category	Description
1.	Cin1 ESR	1.519 mOhm	Capacitor	Cin Capacitor ESR
2.	Cin1 IRMS	1.478 A	Capacitor	Input Capacitor Cin1 RMS Ripple Current
3.	Cin1 Pd	13.261 mW	Capacitor	Input capacitor power dissipation
4.	Cin2 ESR	1.519 mOhm	Capacitor	Cin Capacitor ESR
5.	Cin2 IRMS	1.239 A	Capacitor	Input Capacitor Cin2 RMS Ripple Current
6.	Cin2 Pd	9.319 mW	Capacitor	Input capacitor power dissipation
7.	Cout1 ESR	1.165 mOhm	Capacitor	Cout Capacitor ESR
8.	Cout2 ESR	1.005 mOhm	Capacitor	Cout Capacitor ESR
9.	Cout_ch1 IRMS	508.465 mA	Capacitor	Output Channel 1 Capacitor RMS ripple current
10.	Cout_ch1 Pd	301.11 μ W	Capacitor	Output channel 1 capacitor power dissipation
11.	Cout_ch2 IRMS	359.906 mA	Capacitor	Output Channel 2 Capacitor RMS ripple current
12.	Cout_ch2 Pd	130.23 μ W	Capacitor	Output channel 2 capacitor power dissipation
13.	IC Pd	3.578 W	IC	IC power dissipation
14.	IC Tj	75.445 degC	IC	IC junction temperature
15.	IC Tolerance	5.0 mV	IC	IC Feedback Tolerance
16.	ICThetaJA Effective	12.7 degC/W	IC	Effective IC Junction-to-Ambient Thermal Resistance
17.	Iin Avg	3.96 A	IC	Average input current
18.	Cin1 Pd	13.261 mW	Power	Input capacitor power dissipation
19.	Cin2 Pd	9.319 mW	Power	Input capacitor power dissipation
20.	Cout_ch1 Pd	301.11 μ W	Power	Output channel 1 capacitor power dissipation
21.	Cout_ch2 Pd	130.23 μ W	Power	Output channel 2 capacitor power dissipation
22.	IC Pd	3.578 W	Power	IC power dissipation
23.	Total Pd	3.601 W	Power	Total Power Dissipation
24.	BOM Count	23	System	Total Design BOM count
25.	Duty Cycle 1	39.862 %	System	Duty cycle for Channel 1
26.	Duty Cycle 2	21.662 %	System	Duty cycle for Channel 2
27.	Efficiency	81.812 %	System	Steady state efficiency

#	Name	Value	Category	Description
28.	FootPrint	272.0 mm ²	System Information	Total Foot Print Area of BOM components
29.	Frequency	2.0 MHz	System Information	Switching frequency
30.	Iout transient step used for Cout1 calculations	3.0 A	System Information	Custom Transient current step requirement that was used for Cout selection (A).
31.	Iout transient step used for Cout2 calculations	3.0 A	System Information	Custom Transient current step requirement that was used for Cout selection (A).
32.	Iout1	6.0 A	System Information	Iout1 operating point
33.	Iout2	6.0 A	System Information	Iout2 operating point
34.	Minimum Cout1 required for stability	134.141 µF	System Information	Minimum Cout required for stability
35.	Minimum Cout2 required for stability	273.8 µF	System Information	Minimum Cout required for stability
36.	Overshoot Value for Cout1	5.442 mV	System Information	Theoretical Vout Overshoot Value
37.	Overshoot Value for Cout2	4.953 mV	System Information	Theoretical Vout Overshoot Value
38.	Pout1	10.8 W	System Information	Total output power
39.	Pout2	5.4 W	System Information	Total output power
40.	SW1 Ipk	6.881 A	System Information	Peak switch current
41.	SW2 Ipk	6.623 A	System Information	Peak switch current
42.	Total BOM	\$18.8	System Information	Total BOM Cost
43.	Undershoot Value for Cout1	10.564 mV	System Information	Theoretical Vout Undershoot Value
44.	Undershoot Value for Cout2	4.572 mV	System Information	Theoretical Vout Undershoot Value
45.	Vin	5.0 V	System Information	Vin operating point
46.	Vout Ripple requirement used for Cout1 calculations	1.0 %	System Information	Custom maximum output ripple requirement that was used for Cout selection(% of Vout).
47.	Vout Ripple requirement used for Cout2 calculations	1.0 %	System Information	Custom maximum output ripple requirement that was used for Cout selection(% of Vout).
48.	Vout transient requirement used for Cout1 calculations	3.0 %	System Information	Custom Transient voltage change requirement that was used for Cout selection (% of Vout).
49.	Vout transient requirement used for Cout2 calculations	3.0 %	System Information	Custom Transient voltage change requirement that was used for Cout selection (% of Vout).
50.	Vout1	1.8 V	System Information	Operational Voltage 1
51.	Vout1 p-p	2.051 mV	System Information	Peak-to-peak output1 ripple voltage
52.	Vout1Tolerance	2.475 %	System Information	Vout Tolerance based on IC Tolerance (no load) and voltage divider resistors if applicable
53.	Vout1_Actual	1.805 V	System Information	Vout Actual calculated based on selected voltage divider resistors
54.	Vout2	900.0 mV	System Information	Operational Voltage 2
55.	Vout2 p-p	1.253 mV	System Information	Peak-to-peak output2 ripple voltage
56.	Vout2Tolerance	1.911 %	System Information	Vout Tolerance based on IC Tolerance (no load) and voltage divider resistors if applicable
57.	Vout2_Actual	903.0 mV	System Information	Vout Actual calculated based on selected voltage divider resistors

Design Inputs

Name	Value	Description
Iout	6.0	Maximum Output Current
Iout1	6.0	Output Current #1
Iout2	6.0	Output Current #2
VinMax	5.0	Maximum input voltage
VinMin	5.0	Minimum input voltage
Vout	1.8	Output Voltage
Vout1	1.8	Output Voltage #1
Vout2	900.0 m	Output Voltage #2

Name	Value	Description
base_pn	TPSM5D1806	Base Product Number
source	DC	Input Source Type
Ta	30.0	Ambient temperature

WEBENCH® Assembly

Component Testing

Some published data on components in datasheets such as Capacitor ESR and Inductor DC resistance is based on conservative values that will guarantee that the components always exceed the specification. For design purposes it is usually better to work with typical values. Since this data is not always available it is a good practice to measure the Capacitance and ESR values of C_{in} and C_{out} , and the inductance and DC resistance of L1 before assembly of the board. Any large discrepancies in values should be electrically simulated in WEBENCH to check for instabilities and thermally simulated in WebTHERM to make sure critical temperatures are not exceeded.

Soldering Component to Board

If board assembly is done in house it is best to tack down one terminal of a component on the board then solder the other terminal. For surface mount parts with large tabs, such as the DPAK, the tab on the back of the package should be pre-tinned with solder, then tacked into place by one of the pins. To solder the tab down to the board place the iron down on the board while resting against the tab, heating both surfaces simultaneously. Apply light pressure to the top of the plastic case until the solder flows around the part and the part is flush with the PCB. If the solder is not flowing around the board you may need a higher wattage iron (generally 25W to 30W is enough).

Initial Startup of Circuit

It is best to initially power up the board by setting the input supply voltage to the lowest operating input voltage 5.0V and set the input supply's current limit to zero. With the input supply off connect up the input supply to V_{in} and GND. Connect a digital volt meter and a load if needed to set the minimum load of the design from V_{out} and GND. Turn on the input supply and slowly turn up the current limit on the input supply. If the voltage starts to rise on the input supply continue increasing the input supply current limit while watching the output voltage. If the current increases on the input supply, but the voltage remains near zero, then there may be a short or a component misplaced on the board. Power down the board and visually inspect for solder bridges and recheck the diode and capacitor polarities. Once the power supply circuit is operational then more extensive testing may include full load testing, transient load and line tests to compare with simulation results.

Load Testing

The setup is the same as the initial startup, except that an additional digital voltmeter is connected between V_{in} and GND, a load is connected between V_{out} and GND and a current meter is connected in series between V_{out} and the load. The load must be able to handle at least rated output power + 50% (7.5 watts for this design). Ideally the load is supplied in the form of a variable load test unit. It can also be done in the form of suitably large power resistors. When using an oscilloscope to measure waveforms on the prototype board, the ground leads of the oscilloscope probes should be as short as possible and the area of the loop formed by the ground lead should be kept to a minimum. This will help reduce ground lead inductance and eliminate EMI noise that is not actually present in the circuit.

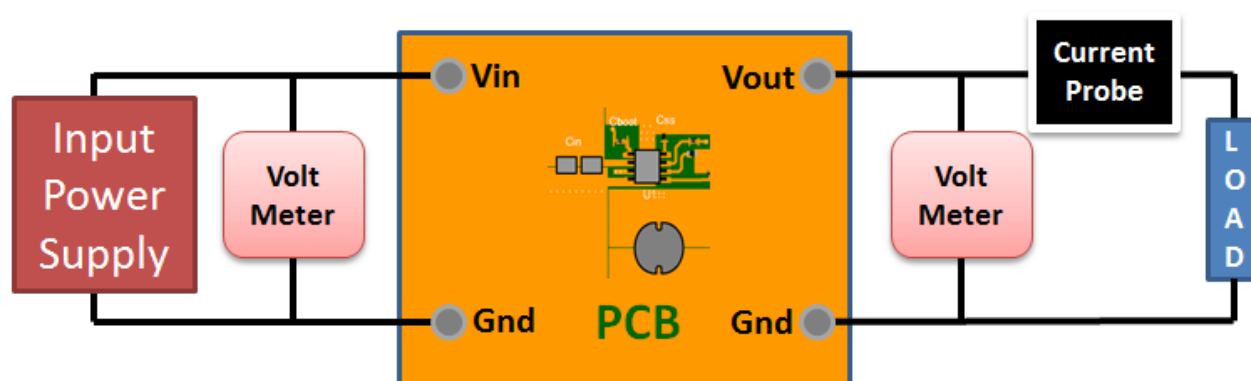

Design Assistance

1. Master key : 99CBB26647818962F696164E0239B07C[v1]
2. **TPSM5D1806** Product Folder : <http://www.ti.com/product/TPSM5D1806> : contains the data sheet and other resources.

Important Notice and Disclaimer

TI provides technical and reliability data (including datasheets), design resources (including reference designs), application or other design advice, web tools, safety information, and other resources AS IS and with all faults, and disclaims all warranties. These resources are intended for skilled developers designing with TI products. You are solely responsible for (1) selecting the appropriate TI products for your application, (2) designing, validating and testing your application, and (3) ensuring your application meets applicable standards, and any other safety, security, or other requirements.

These resources are subject to change without notice. TI grants you permission to use these resources only for development of an application that uses the TI products described in the resource. Other reproduction and display of these resources is prohibited. No license is granted to any other TI intellectual property right or to any third party intellectual property right. TI disclaims responsibility for, and you will fully indemnify TI and its representatives against, any claims, damages, costs, losses, and liabilities arising out of your use of these resources.

Providing these resources does not expand or otherwise alter TI's applicable Terms of Sale or other applicable terms available either on ti.com or provided in conjunction with TI products.