

XSLIDE™ Assemblies Owner's Manual

Important User Information

This information is for the end user of XSlide Assemblies. The end user should read this document and retain it for future reference.

Table of Contents

Precautions.....1	Limit Switches.....6	Load Attachment.....10
Terminology.....2	Configurations.....7	Lubrication.....11
Specifications.....2	Cleat Mounting.....8	Adjustments.....11
Load Capacity.....3	End Mounting.....9	Nut Replacement.....11
Model Numbers.....4	XY Mounting.....9	Warranty.....12
Motor Mounting.....5	XZ Mounting.....9	Contact Information...12
Wiring.....6	XZ/Gusset Mounting.10	

⚠ WARNING *Overloading, improper mounting, or misapplication of this product may result in serious injury. Suitability for a particular application of this product resides with the end user.*

⚠ CAUTION *Stay clear of moving parts when operating*



⚠ *XSlide Assemblies must not be used in applications where Operator Error, Mechanical Failure, Knob/Thumb Lock Failure, Motor, Wiring, Controller, or Limit Switch Failure could result in personal injury. If you feel this product is not suitable for your application then, immediately contact your distributor or Velmex to obtain a RMA number to return this product for a refund or credit.*

XSlide Terminology

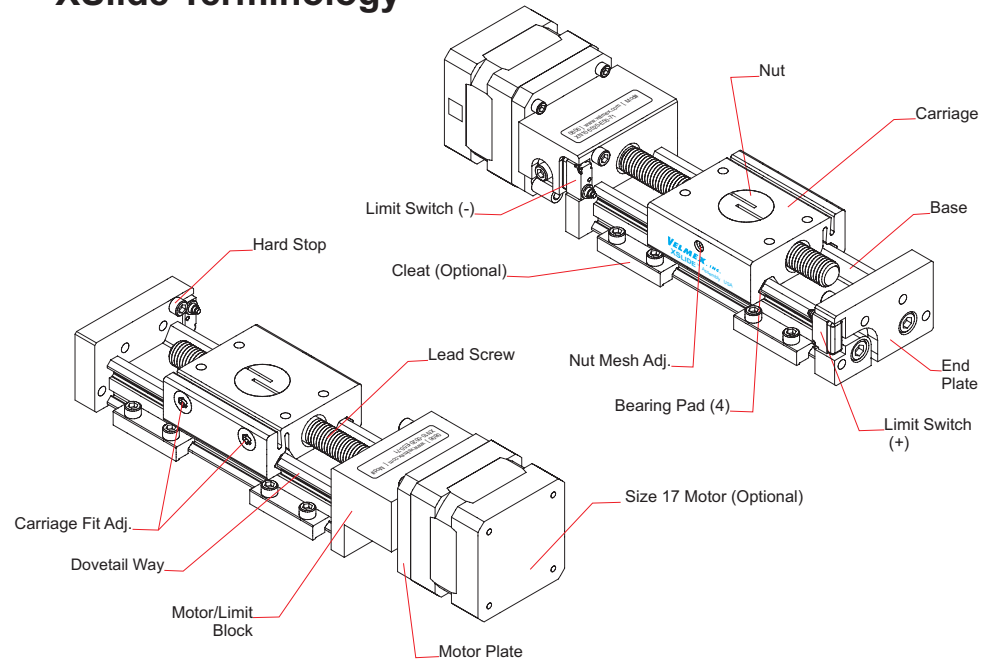

Specifications

Coefficient of Sliding Friction: 0.09

Cantilevered Loads: Equivalent center load= (dxF) +F
 d= distance from center (inches)
 F= Load (lbs)

Minimum Motor Torque required: 25 in-oz

Repeatability (short term): 0.0001" (0.0025mm)

Straight Line Accuracy: 0.001"/10" (0.025mm/25cm)

Screw Lead Accuracy: 0.003"/10" (0.076mm/25cm)
 Optional 0.0015"/10" available

Operating Temperature: 0 to 180° F (-18 to 82° C)
 (Optional materials for wider temperature ranges available)

Materials

Base, Carriage, Cleats, Ends: Hard alloy aluminum
 Lead Screw: Nickel plated Steel or 303 SS
 Lead Screw Nut: Delrin AF
 Lead Screw Coupling: Steel

Maximum Load Capacity

⚠ WARNING Overloading, improper mounting, or misapplication of this product may result in serious injury.

⚠ Exceeding the load/speed limits shown in the graph below will result in rapid Lead Screw and Nut wear. Consult our engineering department for other duty cycles and temperatures.

MAXIMUM RATINGS

Load	Dynamic		Static		Momentary	
	lb	kg	lb	kg	lb	kg
Fw	35	15.9	35	15.9	140	63.6
Ft1	10	4.5	20	9.1	120	54.5
Ft2	10	4.5	20	9.1	40	18.2
	in-lbs	N-m	in-lbs	N-m	in-lbs	N-m
Fms	32	3.6	65	7.3	125	14.0
Fmi	22	2.5	45	5.0	88	9.9

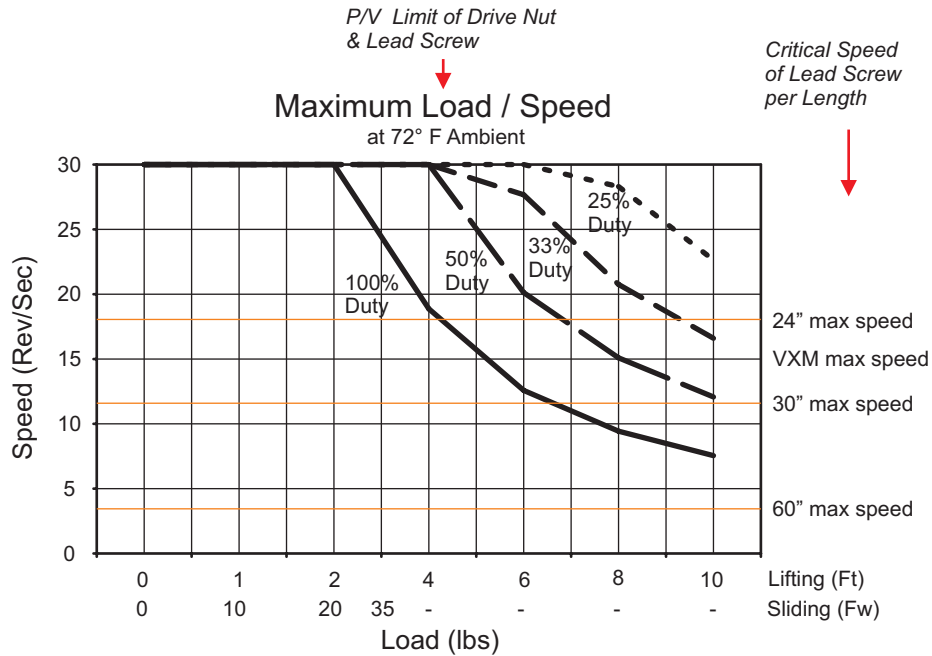
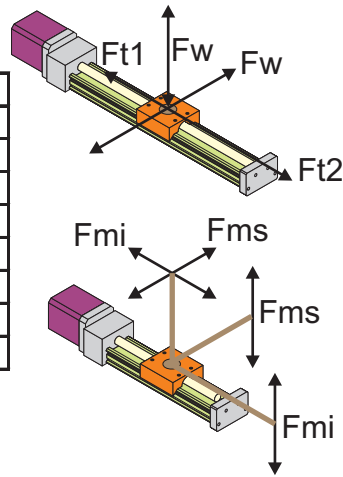

Model Numbers

Use the following table to identify the characteristics of your XSlide. The Model number like the one shown below is located on the top of the XSlide (see illustration below.)

X N 1 0 - 0 0 4 0 - E 0 1 - 7 1

Lead Screw	Advance/Turn
Blank	None
M01	1.00 mm
M02	2.00 mm
E25	0.025 Inches
E50	0.050 Inches
E01	0.10 Inches
E02	0.20 Inches
E04	0.40 Inches

Options

- Mounting
- Blank = None
- 11 = Basic Knob
- 70 = NEMA 17 Motor Mount
- 71 = NEMA 17 Mount & Lmt Swts
- 20 = NEMA 23 Motor Mount
- 21 = NEMA 23 Mount & Lmt Swts

Version
N = Nut/Screw Drive
F = Free Sliding

Design Travel (Tenths of Inches)
Standard travel lengths (Inches):
2,4,6,8,12,18,24,30
Other travels available: Screw Drive to 60", Free Sliding to 120"

Date Code
0806 | www.velmex.com [Mod#
XN10-0020-E50-71
Model#

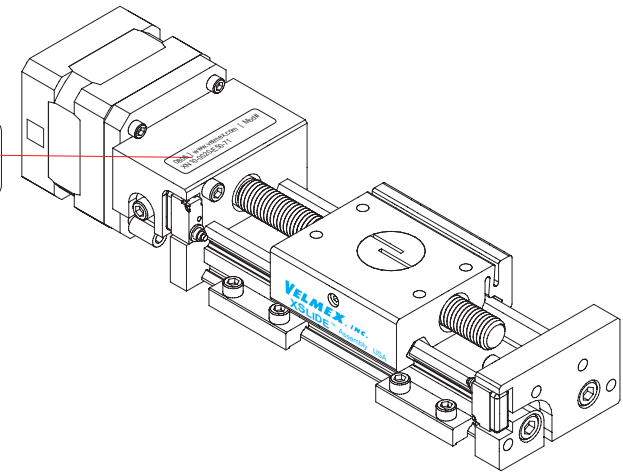

Motor Mounting

This procedure is for users who did not purchase or supply a motor for factory mounting. Before attaching the motor the bearing/coupling assembly must be installed and properly preloaded. Refer to the diagram below for proper part location and coupling orientation. For NEMA size 17 motors apply a 10 lb force (20lbs for NEMA 23 motors) on the assembly and tighten only the coupling screw closest to the motor with a 3/32" hex key.

For the following steps, keep the lead screw/motor assembly vertical to prevent weight of motor from stressing lead screw/nut. Slip the motor coupling onto the lead screw, while holding the motor/coupling, progressively tighten all four coupling screws to a final torque of 15 in-lb.

Rotate the lead screw until the carriage is at the motor end just short of touching the limit switch. This will insure the motor centers to the center of the lead screw. Install and tighten the four cap head screws between the motor plate/motor.

The lead screw drive nut may need adjustment after motor mounting, refer to the Nut Adjustment section for procedure.

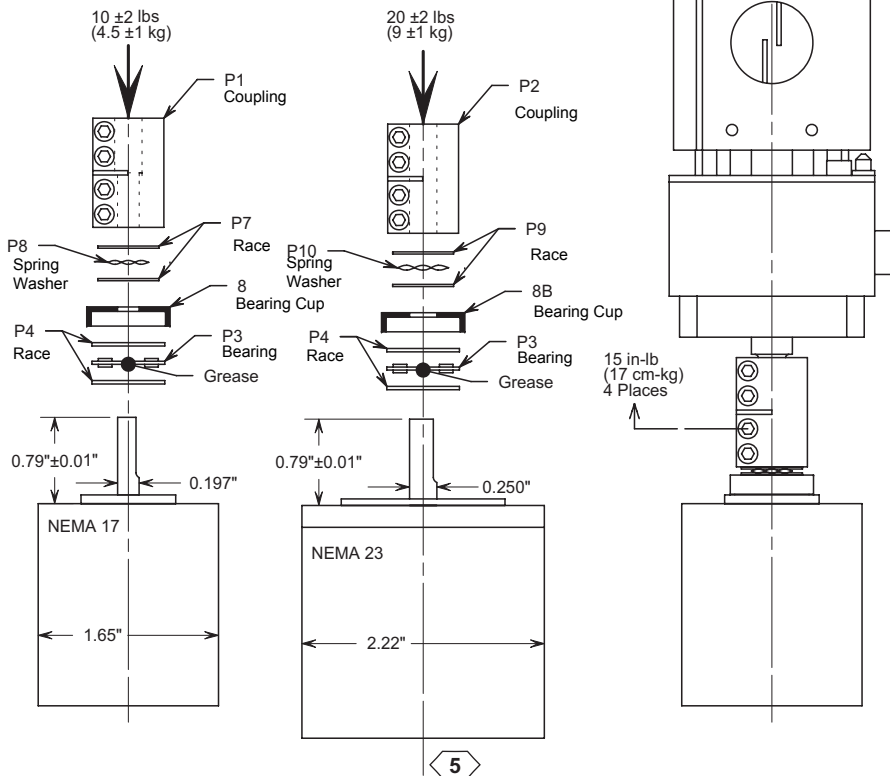
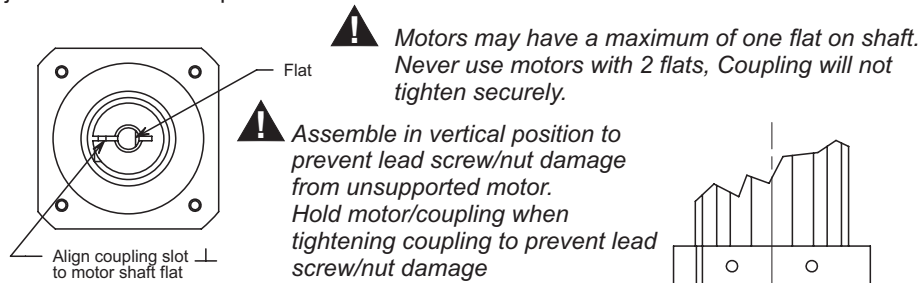

5

Motor Wiring (for Velmex installed step motors)

Pin	Motor	Cable (6 wire)	Cable (4 wire)	Slo-Syn	Vexta	Pacific Scientific*
1	BC	W	-	W	W	W/Y & W/R
2	B2	Gn	Gn	Gn	Bu	R
3	AC	Bk	-	Bk	Y	W/Bk & W/O
4	A2	Or	Bk	W/R	Bk	O
5	A1	R	R	R	Gn	Bk
6	B1	Bu	W	W/Gn	R	Y

* 8 lead motor with wires combined at AC and BC for 6 lead configuration

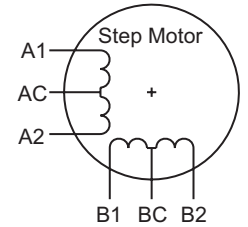

Connector on Motor

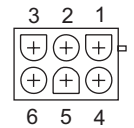

Amp 1-480705-0 (mates with: 1-480704-0)

Step	A1	A2	B1	B2	BC & AC
1	Gnd	N/C	Gnd	N/C	+V
2	N/C	Gnd	Gnd	N/C	
3	N/C	Gnd	N/C	Gnd	
4	Gnd	N/C	N/C	Gnd	
1	Gnd	N/C	Gnd	N/C	

Gnd = Ground level
N/C = No Connection
+V = Motor label voltage or, current limited over-drive voltage

Bipolar Full Step

Step	A1	A2	B1	B2
1	+	-	-	+
2	-	+	-	+
3	-	+	+	-
4	+	-	+	-
1	+	-	-	+

+ = Positive current flow
- = Negative current flow

Limit Switches

Limit switches are end of travel sealed snap action type switches. They have 1.4 mm over-travel capability.

The hard stops at both ends of the XSlide protect the limits switches from over-travel if the slide is inadvertently run without the switches connected properly. The hard stops should never be removed or be used in-place of electronic limits switches.

The limit switches have the following maximum rating:
2A resistive load@12VDC, 1A resistive load@24VDC, 0.5A resistive load@42VDC

	Pin	Switch	Cable
Inner Switch (Motor End)*	1	C	W
	2	NC	R
Outer Switch (End Plate)	3	NC	Gn
	4	C	Bk

Connector on Switch Harness

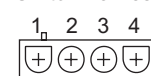

Amp 1-480703-0 (mates with: 1-480702-0)

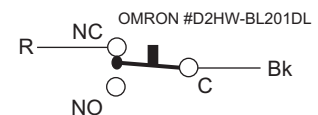

Switches are wired on the normally closed (NC) terminals.

* Negative direction on Velmex Controllers (carriage moves toward motor end)

6

Configurations

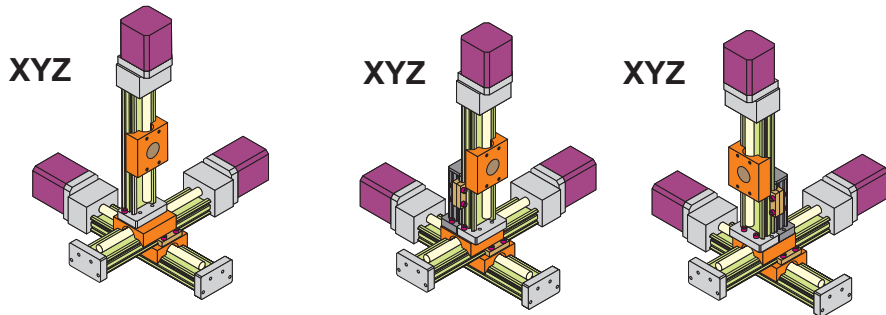
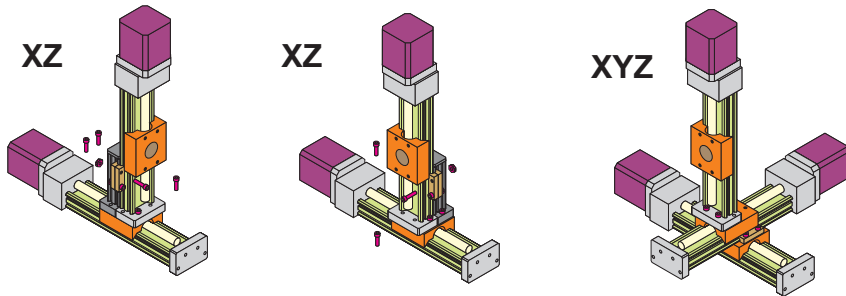
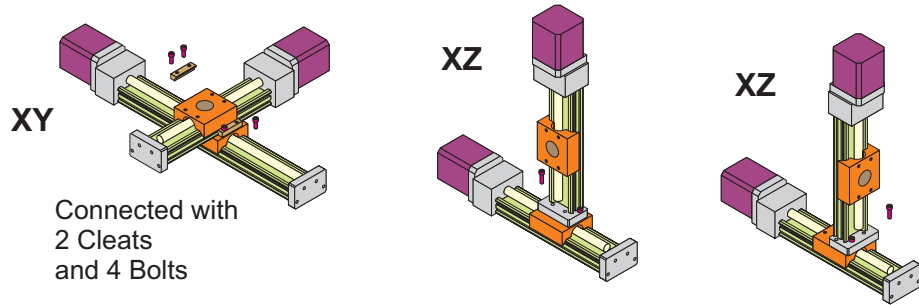
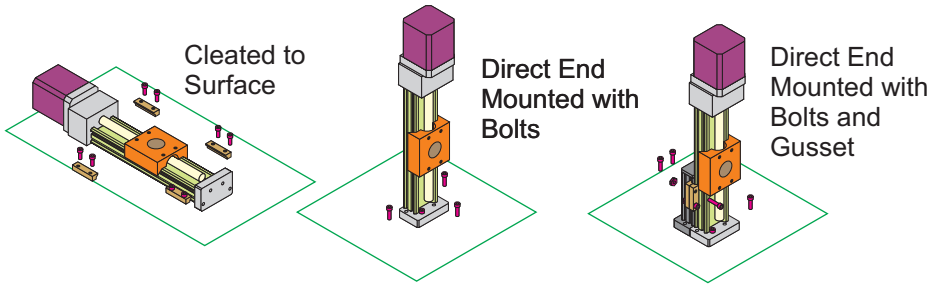

Cleated to Surface

The XSlide Assembly base should be mounted with Velmex XMC-2 cleats to a reasonably flat surface. Inaccuracies and binding can result if mounted to non-flat surfaces. Mounting surface should be metal and have 6-32 UNC threaded holes with a minimum thread depth of 0.15"

Refer to drawing and table below for cleat placement. Use cleats in pairs with a pair 0.6" from each end to first mounting hole. All other cleats should be equally spaced between them. Use more cleats for heavy off center loads and for more rigidity.

Attach cleats with Velmex XMB-1 bolts or equal grade 8 bolts. Start with bolts finger tight and then tighten bolts progressively alternating sides and diagonals. Finish by tightening bolts to 17 in-lbs.

Thread locking compound (Loctite™) is recommended for all mounting bolts.

Design		Lighter Loads					Heavier Loads		
		L	L	C	CC	CC	C	CC	CC
Travel (inches)	Travel (cm)	Length (inches)	Length (cm)	# Cleats	Spacing (inches)	Spacing (cm)	# Cleats	Spacing (inches)	Spacing (cm)
2	5.08	4.5	11.43	4	2.570	6.528	4	2.570	6.528
4	10.16	6.5	16.51	4	4.570	11.608	6	2.285	5.804
6	15.24	8.5	21.59	4	6.570	16.688	6	3.285	8.344
8	20.32	10.5	26.67	6	4.285	10.884	8	2.857	7.256
12	30.48	14.5	36.83	6	6.285	15.964	10	3.143	7.982
18	45.72	20.5	52.07	6	9.285	23.584	12	3.714	9.434
24	60.96	26.5	67.31	8	8.190	20.803	14	4.095	10.401
30	76.20	32.5	82.55	10	7.643	19.412	16	4.367	11.093

C = Total # of Cleats

$$CC = \frac{L - 1.930"}{(C/2) - 1}$$

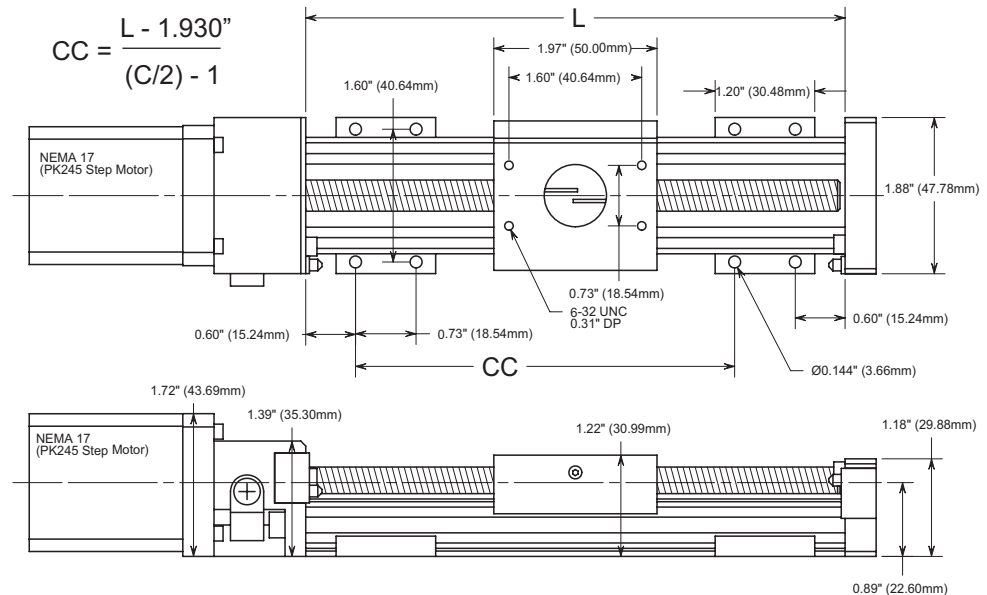

End Mounting

Refer to drawing at right for hole pattern for end mounting. Mounting surface should be metal and have 6-32 UNC threaded holes with a minimum thread depth of 0.15". Use four Velmex XMB-1 or equal grade 8 bolts. Start with bolts finger tight and then tighten bolts progressively alternating sides and diagonals. Finish by tightening bolts to 17 in-lbs. *Thread locking compound (Loctite) is recommended for all mounting bolts.*

⚠ WARNING

Cantilever load on end plate must not exceed 29 ft-lbs.

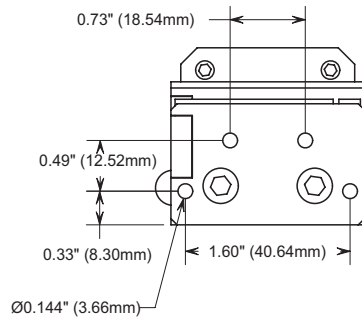

XY Mounting

Attach Y axis base to X axis carriage with a pair of XMC-2 cleats and four XMB-1 bolts (6-32 x 3/8" socket head cap.) Start with bolts finger tight and then tighten bolts progressively alternating side to side and diagonally. Finish by tightening bolts to 17 in-lbs. *Thread locking compound (Loctite) is recommended for all mounting bolts.*

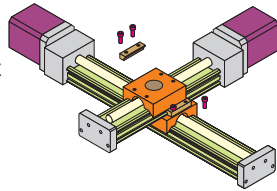

⚠ WARNING

A pair of properly installed cleats have 190 lbs of holding capacity before slipping. However, if the cleats loosen due to vibration or improper tightening the XSlide stage can slip resulting in damage to external equipment, or serious injury. In critical applications cleats should be drilled and pinned to the XSlide base.

XZ Mounting (End Plate To Carriage)

Attach Z axis end plate to X or Y axis carriage with two XMB-2 bolts (6-32 x 1/2" socket head cap.) Start with bolts finger tight and then tighten bolts progressively alternating side to side. Finish by tightening bolts to 17 in-lbs.

Thread locking compound (Loctite) is recommended for all mounting bolts.

⚠ CAUTION

For light loads only, see "XZ Mounting (End Plate/Gusset To Carriage)" for a more rigid connection.

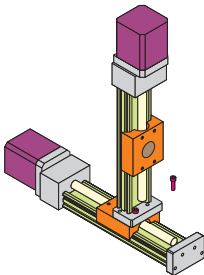
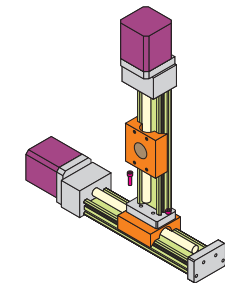

XZ Mounting (End Plate/Gusset To Carriage)

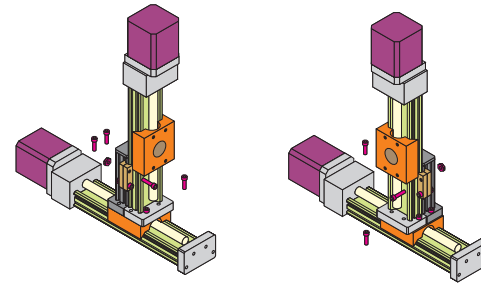

Gusset Assembly

Includes the following:

- One bracket with end plates.
- Four XMC-2 cleats.
- Four 6-32 x 5/8" skt hd cap bolts.
- Four 6-32 hex nuts.



1. Set the gusset and Z axis on the carriage of the X axis. See sketch at right. Insert four XMB-2 bolts (6-32 x 1/2" socket head cap) but **do not tighten**. Fasten gusset to base of Z axis with supplied cleats/bolts/nuts, tighten **finger tight only**.
2. Tighten Z Axis to X with just light (two finger) tension on a wrench. Now tighten the gusset cleats with light tension also. Alternating between gusset cleats and end plate bolts, progressively tighten all bolts to a final torque of 17 in-lbs.

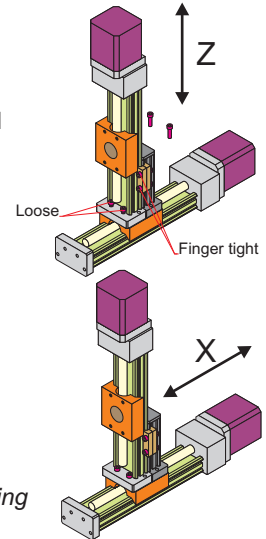

Thread locking compound (Loctite) is recommended for all mounting bolts.

Load Attachment (refer to page 3 for maximum load capacity)

Refer to drawing on page 8 for mounting hole pattern in carriage. When mounting to the carriage surface use four Velmex XMB-1 (6-32 UNC) or equal grade 8 bolts. Bolts must thread into the carriage to a minimum depth of .15" depth. Torque bolts to 17 in-lbs. User attached blocks, plates, etc. must be flat. Attaching non-flat surfaces may distort the carriage causing binding.

Thread locking compound (Loctite) is recommended for all mounting bolts.

Lubrication

XSlide Assemblies can operate without lubrication. Under severe duty applications Velmex BL-1 oil can reduce friction and minimize wear. Using a lubricant other than BL-1 lubricant may damage bearing pads, and nut.

To lubricate XSlide Assembly, traverse carriage near center of travel and apply 2 to 3 drops of oil to the end of carriage at the way surfaces and on the lead screw threads. Apply oil to both end of carriage, refer to the diagram above for lube points.

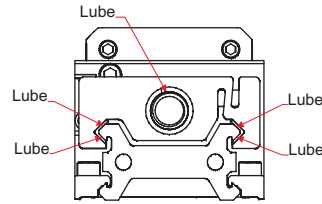

Adjustments

The following adjustments may be necessary after heavy or a long period of use.

Nut

The lead screw nut has adjustable mesh to minimize backlash. To minimize backlash, tighten (Clockwise with 3/32 hex key) nut tension setscrew (see diagram at right) 1/8 of a turn maximum at a time. Test for over tightness by turning lead screw by hand. Lead screw should rotate by twisting with index finger and thumb of one hand. A step motor powered by the Velmex VXM step motor controller should run at 6000 steps per second (15 revs/sec at 70% power setting.)

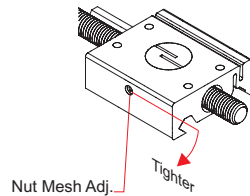

! A squealing lead screw/nut is an indicator that adjustment or lubrication is needed

Carriage

Carriage fit is adjustable by tightening the two head screws on the side of the carriage with appropriate Torx driver (see diagram at right.) Carriage free-play is indicated by a clunking/knocking noise when pulling up and down on the corners of the carriage. To reduce carriage free-play tighten (Clockwise) each bolt equally 1/8 of a turn maximum.

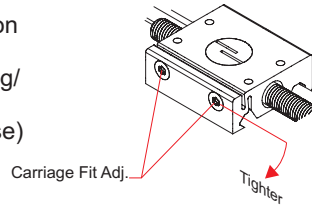

! Over tensioning carriage will result in binding, rapid lead screw, nut, and pad wear.

Nut Replacement

To replace the lead screw nut, first remove the end plate using a 5/32 hex key on the two 10-32 cap head bolts.

Rotate the lead screw until carriage/nut runs off the end of the lead screw. Loosen the nut mesh adj. 2 turns. Push the nut out of the carriage. Insert new nut with slots up and inline with lead screw. Thread the carriage/nut onto the lead screw and rotate the lead screw until the carriage is at the motor end just short of touching the limit switch. Tighten nut mesh adj. until there is some pressure on nut and follow above nut adjustment procedure. Reinstall end plate.

NOTE: If end plate has a lead screw support bearing, traverse carriage to end plate end before tightening end plate bolts.

Warranty

XSlide Assembly products sold by Velmex are warranted to be free from defects for a period of 5 (five) years on all parts. Velmex's obligation under this warranty does not apply to defects due, directly or indirectly, to misuse, abuse, negligence, accidents, or unauthorized repairs, alterations, or lack of maintenance; or to items that would normally be consumed or require replacement due to normal wear. Claims must be authorized, and a return authorization number issued before a product can be returned.

The warranty does not cover items which are not manufactured or constructed by Velmex, Inc. These components are warranted by their respective manufacturer. Under the above warranty, Velmex will, at its option, either repair or replace a nonconforming or defective product.

The above warranty is the only warranty authorized by Velmex. Velmex shall in no event be responsible for any loss of business or profits, downtime or delay, labor, repair, or material costs, injury to person or property or any similar or dissimilar incidental or consequential loss or damage incurred by purchaser, even if Velmex has been advised of the possibility of such losses or damages.

Inasmuch as Velmex does not undertake to evaluate the suitability of any Velmex product for any particular application, the purchaser is expected to understand the operational characteristics of the product, as suggested in documentation supplied by Velmex, and to assess the suitability of Velmex products for this application.

This limited warranty give you specific legal rights which vary from State to State.

Contact Information

By Phone: 585-657-6151 and 800-642-6446

By Fax: 585-657-6153

Email: info@velmex.com

On the Internet: www.velmexXSlide.com
www.velmex.com
www.bislide.com

By mail: Velmex, Inc.
7550 State Route 5 & 20
Bloomfield, NY 14469 USA



Copyright 2006 Velmex Inc. All rights reserved. Velmex, the Velmex logo, UniSlide, BiSlide and XSlide are trademarks of Velmex Inc. All other trademarks are the property of their respective owners.