

| REF-000203014 | 1 | | | | |
|---------------|-------------|-----|------|------|------|
| REV | DESCRIPTION | DWN | CHKR | APVD | DATE |

NOTES:
 1. GLUE ITEM 2 (THORLABS SAPPHIRE PADS) INTO ITEM 1 AS SHOWN WITH SMALL QTY LOCTITE HYSOL 1C OR EQUIVALENT. 3 PLACES.

CHECK-PRINT
 newbry
 02-28-2022 08:37:36 AM

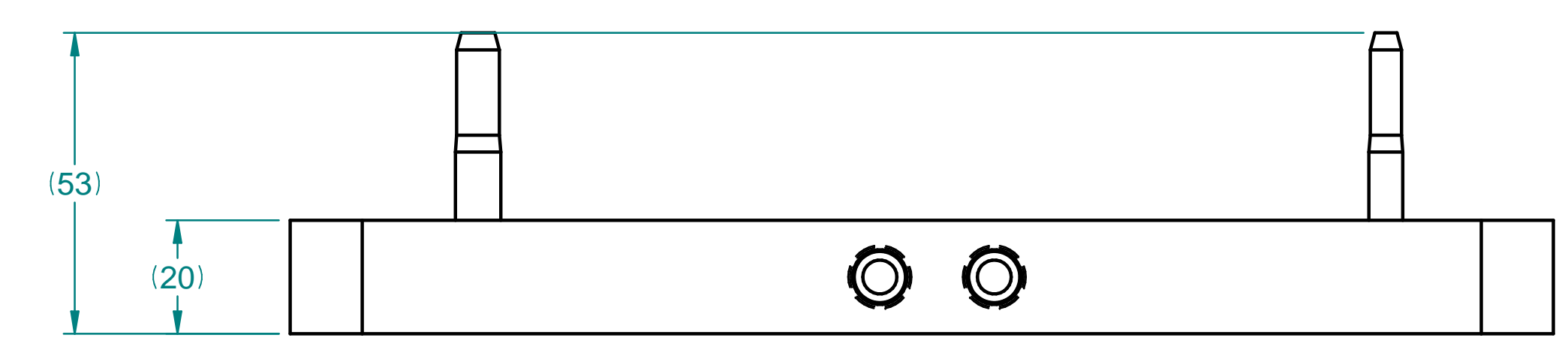
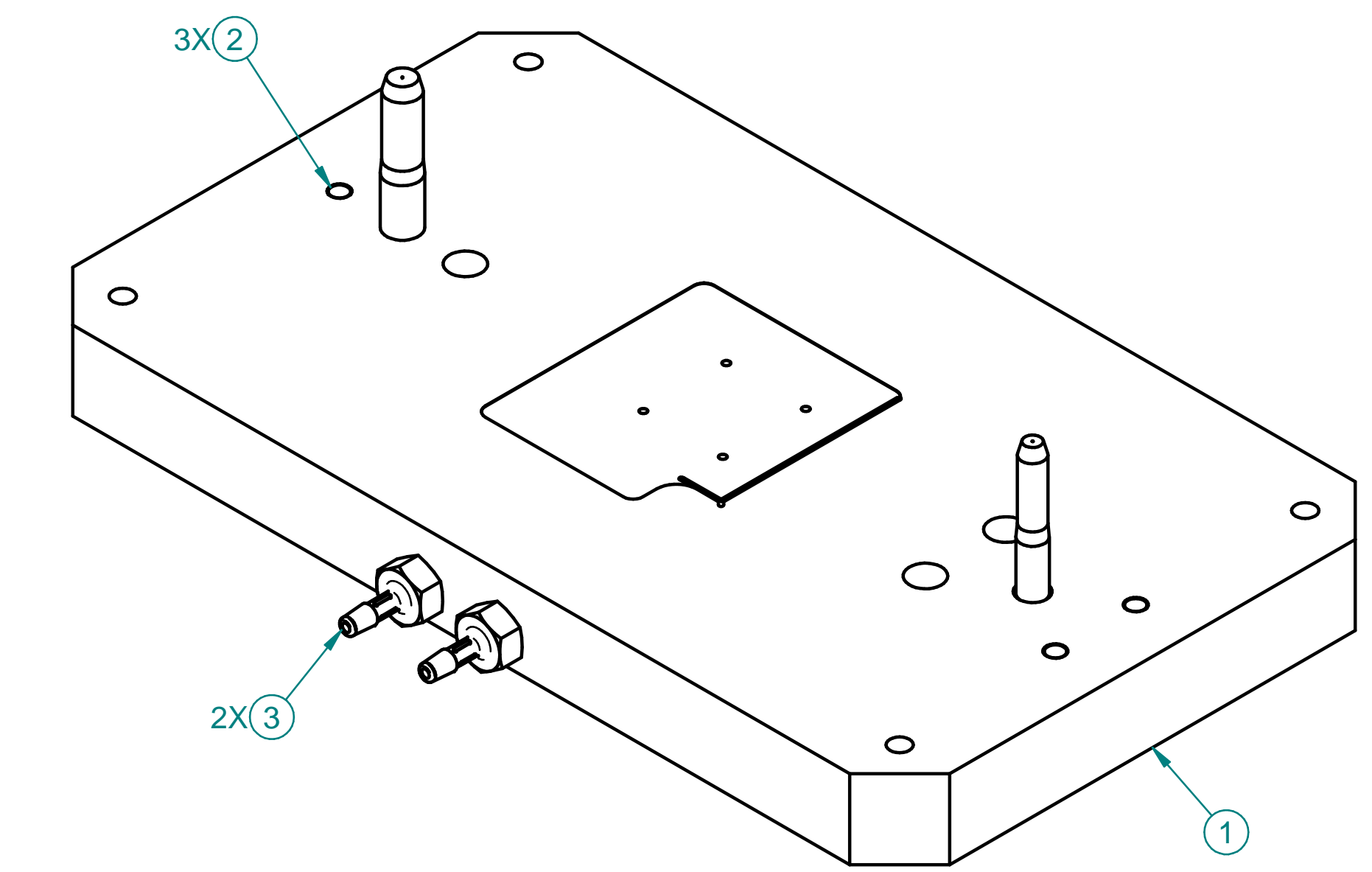
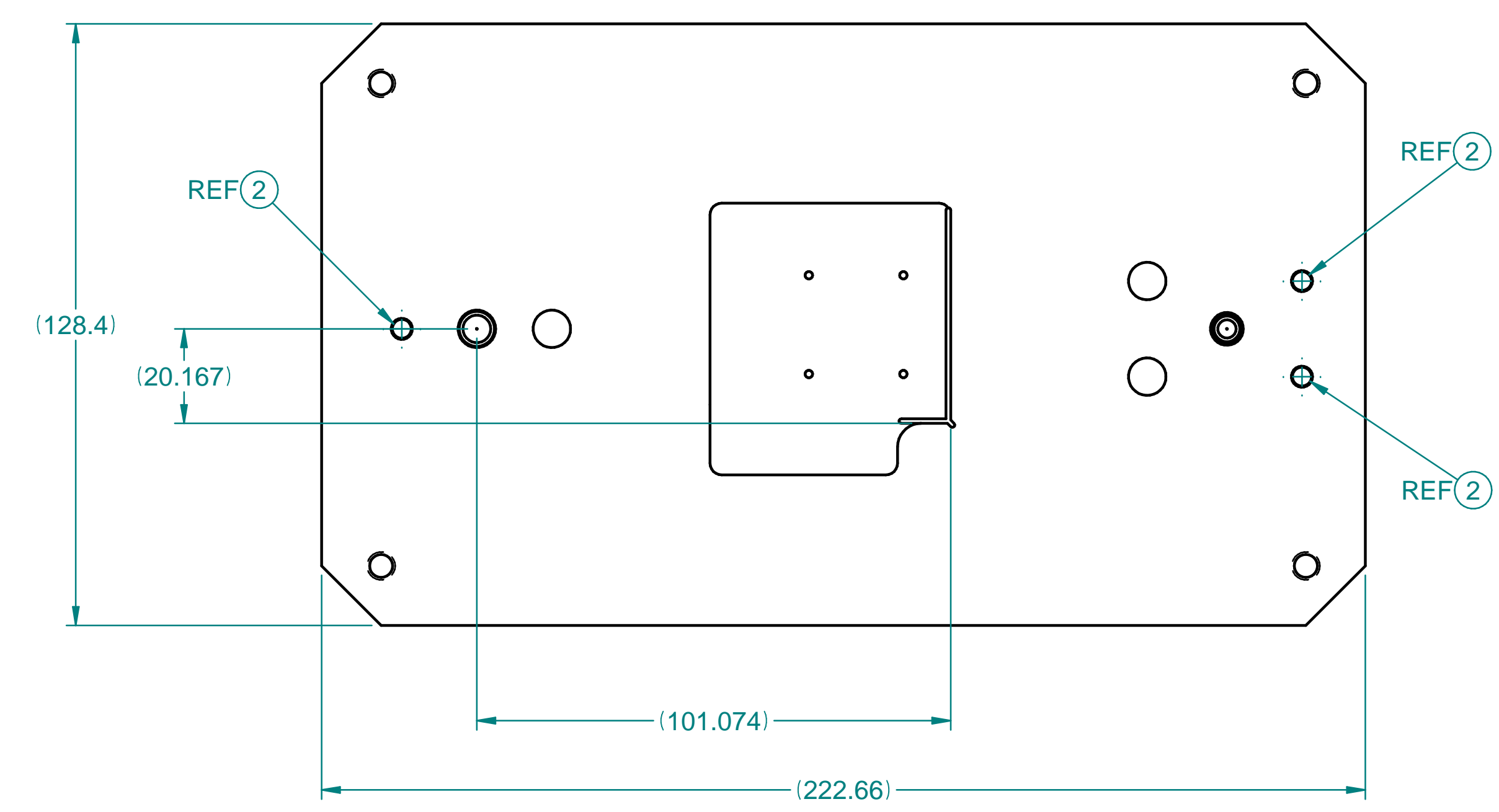

| 3 | | TUBE FITTING, ADAPTER, 1/8 NPT TO 1/8 ID | 2 |
|------|-----------------|---|-----|
| 2 | THORLABS P25SK2 | CONTACT PAD, SAPPHIRE | 3 |
| 1 | REF-000205158 | PICK UP TABLE, RD53a QUAD MODULE, 19-1 OB STAVE | 1 |
| ITEM | NUMBER | DESCRIPTION | QTY |

| DIMENSIONING AND TOLERANCING IS IN ACCORDANCE WITH ASME Y14.5-2009 | | SCALE: 1:1 DO NOT SCALE DRAWING | ESTIMATED MASS: 0 kg | DWG TYPE: ASSY | | | | | | | | | | | | | | | | | | | | |
|--|---|---|----------------------|------------------|-------|--------|--------|--------|--------|--------------------|-------|-------|-------|-------|-------|-------|-----|--|--|--|----------------|-----------------|---------------|---|
| UNLESS OTHERWISE SPECIFIED DIMENSIONS ARE IN MILLIMETERS | | ATLAS INNER PIXEL MECH 19-1 OB STAVE LOADING PICK UP TABLE, RD53a QUAD | | | | | | | | | | | | | | | | | | | | | | |
| TOLERANCES: BREAK EDGES 0.13 - 0.4 INTERNAL CORNERS R 0.4 MAX ANGLE ± 1° ALL SURF 0.8 | | | | | | | | | | | | | | | | | | | | | | | | |
| REF-000202485 | | ENGR S. NEWBRY DWN S. NEWBRY CHKR --- | DATE 20220228 | APPROVALS --- | | | | | | | | | | | | | | | | | | | | |
| NEXT ASSEMBLIES: | <table border="1"> <tr> <th>DIMENSIONS</th> <th>< 6</th> <th>> 6</th> <th>> 30</th> <th>> 120</th> <th>> 315</th> <th>> 1000</th> <th>> 2000</th> </tr> <tr> <th>GENERAL TOLERANCES</th> <td>± 0.1</td> <td>± 0.2</td> <td>± 0.3</td> <td>± 0.5</td> <td>± 0.8</td> <td>± 1.2</td> <td>± 2</td> </tr> </table> | DIMENSIONS | < 6 | > 6 | > 30 | > 120 | > 315 | > 1000 | > 2000 | GENERAL TOLERANCES | ± 0.1 | ± 0.2 | ± 0.3 | ± 0.5 | ± 0.8 | ± 1.2 | ± 2 | <table border="1"> <tr> <td>DRAWING NUMBER</td> <td>REVISION NUMBER</td> </tr> <tr> <td>REF-000203014</td> <td>A</td> </tr> </table> | | | DRAWING NUMBER | REVISION NUMBER | REF-000203014 | A |
| DIMENSIONS | < 6 | > 6 | > 30 | > 120 | > 315 | > 1000 | > 2000 | | | | | | | | | | | | | | | | | |
| GENERAL TOLERANCES | ± 0.1 | ± 0.2 | ± 0.3 | ± 0.5 | ± 0.8 | ± 1.2 | ± 2 | | | | | | | | | | | | | | | | | |
| DRAWING NUMBER | REVISION NUMBER | | | | | | | | | | | | | | | | | | | | | | | |
| REF-000203014 | A | | | | | | | | | | | | | | | | | | | | | | | |