

REV	DESCRIPTION	DWN	CHKR	APVD	DATE
1	CHANGED QUANTITY OF .116 HOLES TO 6X.	GB	DW	DW	3-6 2014

D  
C  
B  
A

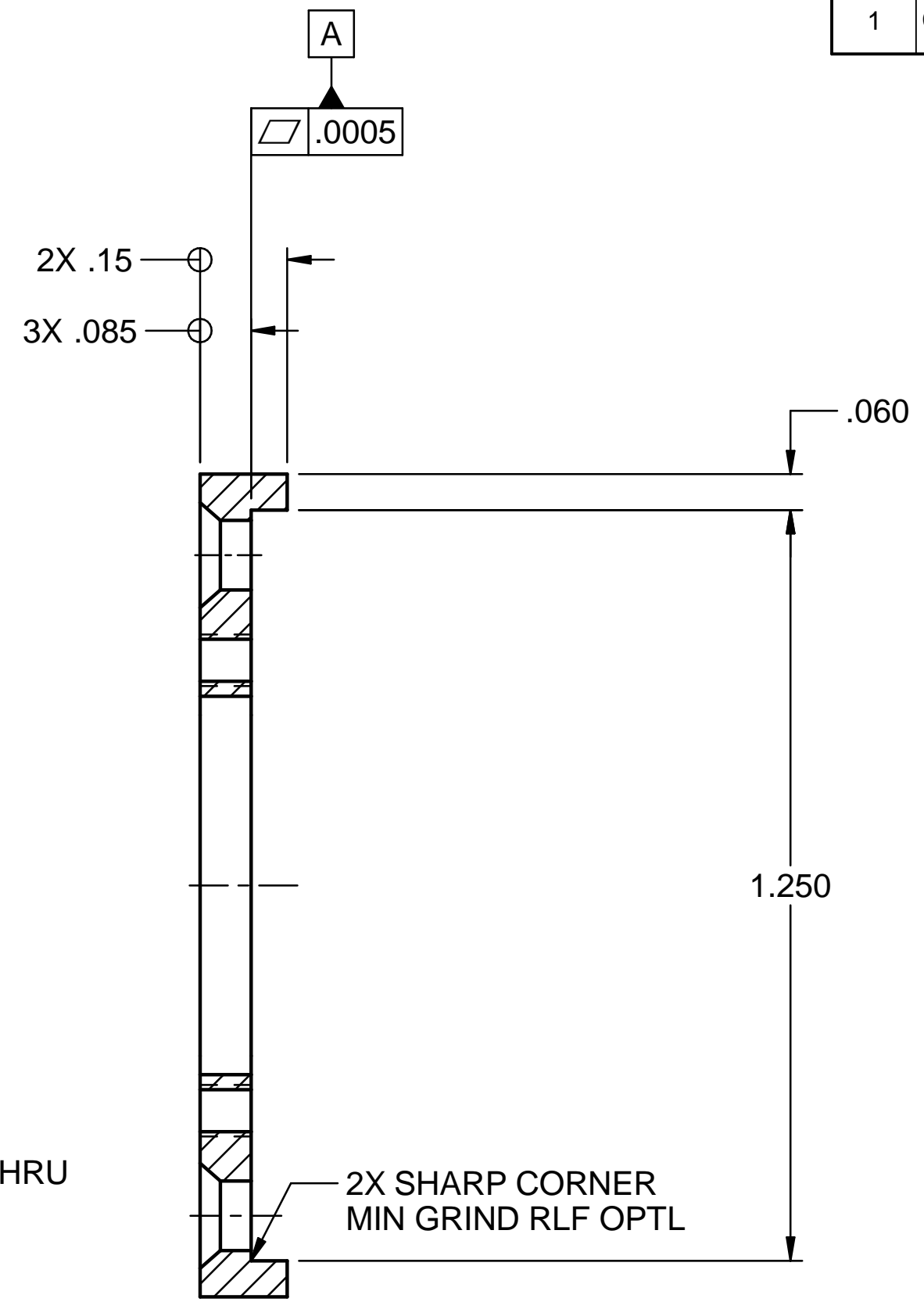
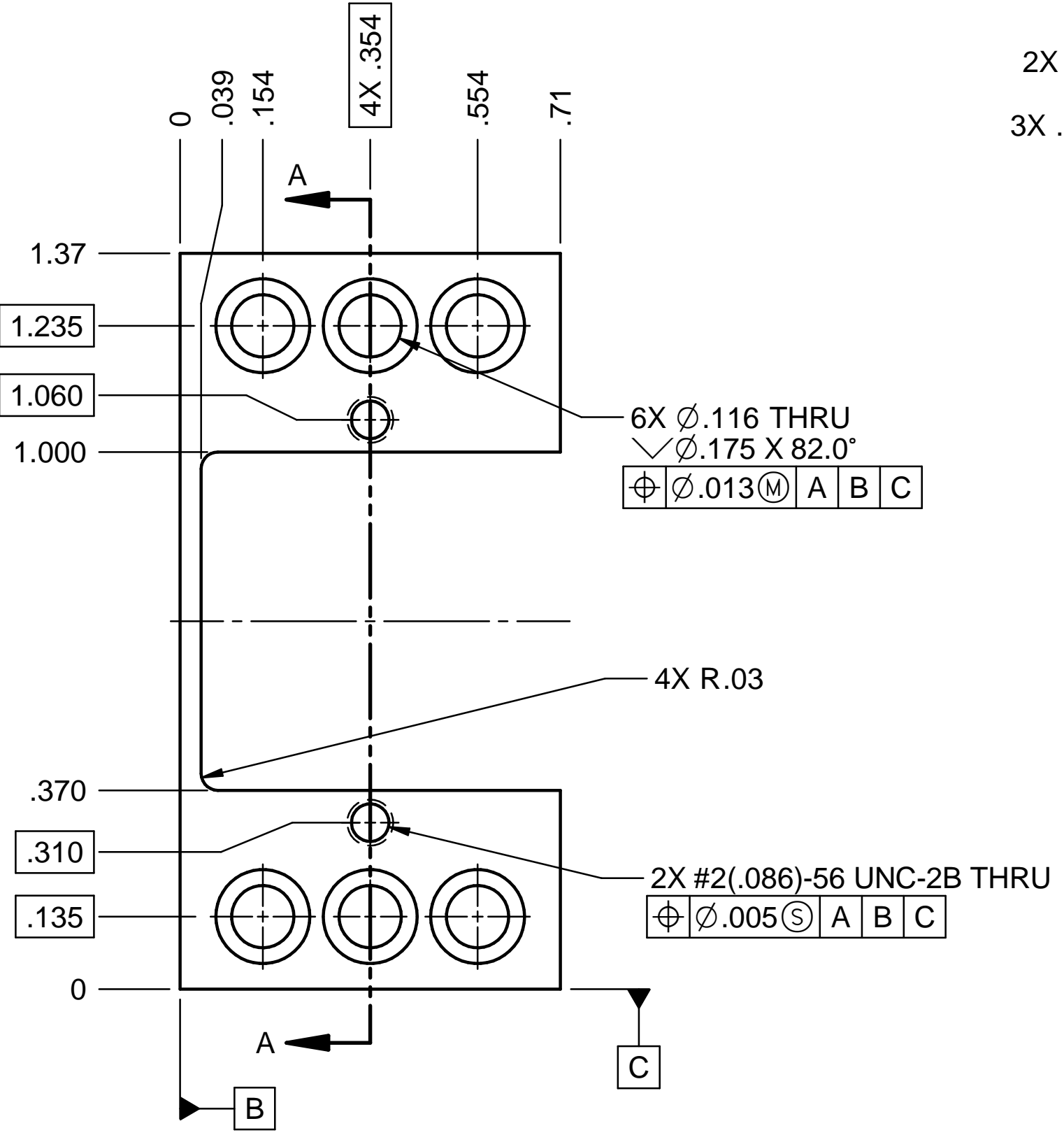

**ULTRA HIGH VAC PART**  
FABRICATE PER FP-202-631-14

NOTES: UNLESS OTHERWISE SPECIFIED

- 1 MATERIAL: SST BAR, IN ACCORDANCE WITH ASTM A276. MILL SOURCE CERTIFICATES REQUIRED, INCLUDING HEAT NUMBER AND CHEMICAL ANALYSIS.
- 2 BAG AND LABEL WITH PART NUMBER AND REVISION.

1	BAR, .188 X .75, 304 SST, ASTM A276
STOCK NO	MATERIAL DESCRIPTION

**ESTIMATED MASS .012 lbm**

--- DIMENSIONING AND TOLERANCING IS IAW ASME Y14.5M-1994 AND Y14.41-2003

UNLESS OTHERWISE SPECIFIED DIMENSIONS ARE IN INCHES. TOLERANCES: BREAK EDGES .005-.015 INTERNAL CORNERS R.015 MAX FRACTIONS ± --- DEC .XX± .01 .XXX± .005 .XXXX± --- ANGLE ± 2.0° ALL SURF 63

SCALE: 4:1 DO NOT SCALE DRAWING

**SLAC** NATIONAL ACCELERATOR LABORATORY **U.S. DEPARTMENT OF ENERGY**

THE DRAWINGS, SPECIFICATIONS AND OTHER DATA HEREIN PROVIDED SHALL NOT BE COPIED, PUBLISHED OR OTHERWISE FURTHER DISSEMINATED WITHOUT PRIOR WRITTEN PERMISSION OF STANFORD UNIVERSITY/SLAC

ENGR D. WALZ DATE D. WALZ C. IVERSON  
DWN G. BOUCHARD 10/24/2013  
CHKR D. WALZ

CAD FILE NAME: pf25740245a-0.dft

**FACET DIAGNOSTICS SYSTEMS**  
**DISK MOUNT ASSY, 18MM**  
**DISK MOUNT, 18MM**

---  
DRAWING NUMBER: PF-257-402-45  
REVISION NUMBER: 1 C

PF-257-402-45  
1  
SH 1 OF 1