

Ultimus V High Precision Fluid Dispenser

Operating Manual



Electronic pdf files of Nordson EFD manuals are also available at www.nordsonefd.com



You have selected a reliable, high-quality dispensing system from Nordson EFD, the world leader in fluid dispensing. The Ultimus™ V high precision dispenser was designed specifically for industrial dispensing and will provide you with years of trouble-free, productive service.

This manual will help you maximize the usefulness of your Ultimus V high precision dispenser.

Please spend a few minutes to become familiar with the controls and features. Follow our recommended testing procedures. Review the helpful information we have included, which is based on more than 50 years of industrial dispensing experience.

Most questions you will have are answered in this manual. However, if you need assistance, please do not hesitate to contact EFD or your authorized EFD distributor. Detailed contact information is provided on the last page of this document.

The Nordson EFD Pledge

Thank You!

You have just purchased the world's finest precision dispensing equipment.

I want you to know that all of us at Nordson EFD value your business and will do everything in our power to make you a satisfied customer.

If at any time you are not fully satisfied with our equipment or the support provided by your Nordson EFD Product Application Specialist, please contact me personally at 800.556.3484 (US), 401.431.7000 (outside US), or Srini.Subramanian@nordsonefd.com.

I guarantee that we will resolve any problems to your satisfaction.

Thanks again for choosing Nordson EFD.

Srini Subramanian
Srini Subramanian, General Manager

Contents

Contents	3
Nordson EFD Product Safety Statement	4
Halogenated Hydrocarbon Solvent Hazards	5
High Pressure Fluids	5
Qualified Personnel	5
Intended Use	6
Regulations and Approvals	6
Personal Safety	6
Fire Safety	7
Preventive Maintenance	7
Important Disposable Component Safety Information	8
Action in the Event of a Malfunction	8
Disposal	8
Specifications	9
Ultimus V Features	10
Unpacking the Dispenser	11
Features and Controls	12
Front Panel	12
Back Panel	13
Initial Setup for Testing	14
Connect Power	14
Connect Foot Pedal	14
Connect Air Input	14
Connect Air Output	14
Attach Syringe Barrel and Tip	14
Dispensing System Setup	15
Using Steady Mode to Dispense a Dot or Stripe or Fill a Cavity	15
Using Timed Mode to Make Repeatable Deposits	16
Using the Vacuum Control Feature for Low Viscosity Fluids	16
Filling the Syringe Barrel	17
Initial Settings	18
Basic Menu Operation	19
Setting the Real Time Clock	19
Setting the Date	19
Setting Units of Pressure	20
Setting Units of Vacuum	20
Setting Language	20
General Operator Lockout Procedures	21
Setting a New Password	22
Clearing a Password	22
Alarm Options Screen	22
Communications Port Options Screen	24
Contrast Control	24
Information Screen	24
Setting Dispense Time, Pressure, And Vacuum	25
Dispense Modes	25
Timed Mode	25
Teach Mode	25
Steady Mode	26
Setting Pressure	26
Setting Vacuum	26
Using Auto Increment Mode	27
Dispense Count Mode	28
Time Mode	28
Auto Sequence Mode	28
Sample Memory Cell Settings	29
Part Numbers	30
Accessories	30

Continued on next page

Contents (continued)

Replacement Parts.....	30
Ultimus V.....	30
Optimeter.....	32
Appendix A — I/O Connector Pin Descriptions	33
Appendix B — RS-232 Connection Protocol.....	37

Nordson EFD Product Safety Statement

WARNING

The safety message that follows has a WARNING level hazard.
Failure to comply could result in death or serious injury.



ELECTRIC SHOCK

Risk of electric shock. Disconnect power before removing covers and / or disconnect, lock out, and tag switches before servicing electrical equipment. If you receive even a slight electrical shock, shut down all equipment immediately. Do not restart the equipment until the problem has been identified and corrected.

CAUTION

The safety messages that follow have a CAUTION level hazard.
Failure to comply may result in minor or moderate injury.



READ MANUAL

Read manual for proper use of this equipment. Follow all safety instructions. Task- and equipment-specific warnings, cautions, and instructions are included in equipment documentation where appropriate. Make sure these instructions and all other equipment documents are accessible to persons operating or servicing equipment.



MAXIMUM AIR PRESSURE

Unless otherwise noted in the product manual, the maximum air input pressure is 7.0 bar (100 psi). Excessive air input pressure may damage the equipment. Air input pressure is intended to be applied through an external air pressure regulator rated for 0 to 7.0 bar (0 to 100 psi).



RELEASE PRESSURE

Release hydraulic and pneumatic pressure before opening, adjusting, or servicing pressurized systems or components.



BURNS

Hot surfaces! Avoid contact with the hot metal surfaces of heated components. If contact can not be avoided, wear heat-protective gloves and clothing when working around heated equipment. Failure to avoid contact with hot metal surfaces can result in personal injury.

Nordson EFD Product Safety Statement (continued)

Halogenated Hydrocarbon Solvent Hazards

Do not use halogenated hydrocarbon solvents in a pressurized system that contains aluminum components. Under pressure, these solvents can react with aluminum and explode, causing injury, death, or property damage. Halogenated hydrocarbon solvents contain one or more of the following elements.

Element	Symbol	Prefix
Fluorine	F	“Fluoro-”
Chlorine	Cl	“Chloro-”
Bromine	Br	“Bromo-”
Iodine	I	“Iodo-”

Check the Safety Data Sheet (SDS) or contact your material supplier for more information. If you must use halogenated hydrocarbon solvents, contact your EFD representative for compatible EFD components.

High Pressure Fluids

High pressure fluids, unless they are safely contained, are extremely hazardous. Always release fluid pressure before adjusting or servicing high pressure equipment. A jet of high pressure fluid can cut like a knife and cause serious bodily injury, amputation, or death. Fluids penetrating the skin can also cause toxic poisoning.

WARNING

Any injury caused by high pressure liquid can be serious. If you are injured or even suspect an injury:

- Go to an emergency room immediately.
- Tell the doctor that you suspect an injection injury.
- Show the doctor the following note.
- Tell the doctor what kind of material you were dispensing.

Medical Alert — Airless Spray Wounds: Note to Physician

Injection in the skin is a serious traumatic injury. It is important to treat the injury surgically as soon as possible. Do not delay treatment to research toxicity. Toxicity is a concern with some exotic coatings injected directly into the bloodstream.

Qualified Personnel

Equipment owners are responsible for making sure that EFD equipment is installed, operated, and serviced by qualified personnel. Qualified personnel are those employees or contractors who are trained to safely perform their assigned tasks. They are familiar with all relevant safety rules and regulations and are physically capable of performing their assigned tasks.

Nordson EFD Product Safety Statement (continued)

Intended Use

Use of EFD equipment in ways other than those described in the documentation supplied with the equipment may result in injury to persons or damage to property. Some examples of unintended use of equipment include:

- Using incompatible materials.
- Making unauthorized modifications.
- Removing or bypassing safety guards or interlocks.
- Using incompatible or damaged parts.
- Using unapproved auxiliary equipment.
- Operating equipment in excess of maximum ratings.
- Operating equipment in an explosive atmosphere.

Regulations and Approvals

Make sure all equipment is rated and approved for the environment in which it is used. Any approvals obtained for Nordson EFD equipment will be voided if instructions for installation, operation, and service are not followed. If the equipment is used in a manner not specified by Nordson EFD, the protection provided by the equipment may be impaired.

Personal Safety

To prevent injury, follow these instructions:

- Do not operate or service equipment unless you are qualified.
- Do not operate equipment unless safety guards, doors, and covers are intact and automatic interlocks are operating properly. Do not bypass or disarm any safety devices.
- Keep clear of moving equipment. Before adjusting or servicing moving equipment, shut off the power supply and wait until the equipment comes to a complete stop. Lock out power and secure the equipment to prevent unexpected movement.
- Make sure spray areas and other work areas are adequately ventilated.
- When using a syringe barrel, always keep the dispensing end of the tip pointing towards the work and away from the body or face. Store syringe barrels with the tip pointing down when they are not in use.
- Obtain and read the Safety Data Sheet (SDS) for all materials used. Follow the manufacturer's instructions for safe handling and use of materials and use recommended personal protection devices.
- Be aware of less-obvious dangers in the workplace that often cannot be completely eliminated, such as hot surfaces, sharp edges, energized electrical circuits, and moving parts that cannot be enclosed or otherwise guarded for practical reasons.
- Know where emergency stop buttons, shutoff valves, and fire extinguishers are located.
- Wear hearing protection to protect against hearing loss that can be caused by exposure to vacuum exhaust port noise over long periods of time.

Nordson EFD Product Safety Statement (continued)

Fire Safety

To prevent a fire or explosion, follow these instructions:

- Shut down all equipment immediately if you notice static sparking or arcing. Do not restart the equipment until the cause has been identified and corrected.
- Do not smoke, weld, grind, or use open flames where flammable materials are being used or stored.
- Do not heat materials to temperatures above those recommended by the manufacturer. Make sure heat monitoring and limiting devices are working properly.
- Provide adequate ventilation to prevent dangerous concentrations of volatile particles or vapors. Refer to local codes or the SDS for guidance.
- Do not disconnect live electrical circuits when working with flammable materials. Shut off power at a disconnect switch first to prevent sparking.
- Know where emergency stop buttons, shutoff valves, and fire extinguishers are located.

Preventive Maintenance

As part of maintaining continuous trouble-free use of this product, Nordson EFD recommends the following simple preventive maintenance checks:

- Periodically inspect tube-to-fitting connections for proper fit. Secure as necessary.
- Check tubing for cracks and contamination. Replace tubing as necessary.
- Check all wiring connections for looseness. Tighten as necessary.
- Clean: If a front panel requires cleaning, use a clean, soft, damp rag with a mild detergent cleaner. DO NOT USE strong solvents (MEK, acetone, THF, etc.) as they will damage the front panel material.
- Maintain: Use only a clean, dry air supply to the unit. The equipment does not require any other regular maintenance.
- Test: Verify the operation of features and the performance of equipment using the appropriate sections of this manual. Return faulty or defective units to Nordson EFD for replacement.
- Use only replacement parts that are designed for use with the original equipment. Contact your Nordson EFD representative for information and advice.

Nordson EFD Product Safety Statement (continued)

Important Disposable Component Safety Information

All Nordson EFD disposable components, including syringe barrels, cartridges, pistons, tip caps, end caps, and dispense tips, are precision engineered for one-time use. Attempting to clean and re-use components will compromise dispensing accuracy and may increase the risk of personal injury.

Always wear appropriate protective equipment and clothing suitable for your dispensing application and adhere to the following guidelines:

- Do not heat syringe barrels or cartridges to a temperature greater than 38° C (100° F).
- Dispose of components according to local regulations after one-time use.
- Do not clean components with strong solvents (MEK, acetone, THF, etc.).
- Clean cartridge retainer systems and barrel loaders with mild detergents only.
- To prevent fluid waste, use Nordson EFD SmoothFlow™ pistons.

Action in the Event of a Malfunction

If a system or any equipment in a system malfunctions, shut off the system immediately and perform the following steps:

1. Disconnect and lock out system electrical power. If using hydraulic and pneumatic shutoff valves, close and relieve pressure.
2. For Nordson EFD air-powered dispensers, remove the syringe barrel from the adapter assembly. For Nordson EFD electro-mechanical dispensers, slowly unscrew the barrel retainer and remove the barrel from the actuator.
3. Identify the reason for the malfunction and correct it before restarting the system.

Disposal

Dispose of equipment and materials used in operation and servicing according to local codes.

Specifications

NOTE: Specifications and technical details are subject to change without prior notification.

Item	Specification
Cabinet size	22.5W x 9.50H x 19.9D cm (8.86W x 3.74H x 7.85D")
Weight	3.4 kg (7.7 lb)
Power adapter	AC input: 100–240 VAC (+/-10%), ~50/60Hz, 0.5 Amp DC output: 24 VDC @ 1.66 Amp
Internal voltage	24 VDC
Cycle rate	Exceeds 600 cycles per minute
Time range	0.0000–9.9999 s
Foot pedal	Voltage: 24 VDC Current: 20 mA
End-of-cycle feedback circuits	5–24 VDC, 100 mA maximum
Cycle initiate	Foot pedal, finger switch, or 5–24 VDC signal
Input air pressure	7.0 bar (100 psi) maximum
Air output	0–7.0 bar (0–100 psi)
Ambient operating conditions	Temperature: 5–50° C (41–122° F) Humidity: 85% RH at 30° C non-condensing Height above sea level: 2,000 m max (6,562 ft)
Product classification	Installation: Category II Pollution: Degree 2
Approvals	CE, TUV, RoHS, WEEE, China RoHS

RoHS标准相关声明 (China RoHS Hazardous Material Declaration)

产品名称 Part Name	有害物质及元素 Toxic or Hazardous Substances and Elements					
	铅 Lead (Pb)	汞 Mercury (Hg)	镉 Cadmium (Cd)	六价铬 Hexavalent Chromium (Cr6)	多溴联苯 Polybrominated Biphenyls (PBB)	多溴联苯醚 Polybrominated Diphenyl Ethers (PBDE)
外部接口 External Electrical Connectors	X	0	0	0	0	0
<p>0: 表示该产品所含有的危险成分或有害物质含量依照EIP-A, EIP-B, EIP-C的标准低于SJ/T11363-2006 限定要求。 Indicates that this toxic or hazardous substance contained in all the homogeneous materials for this part, according to EIP-A, EIP-B, EIP-C is below the limit requirement in SJ/T11363-2006.</p> <p>X: 表示该产品所含有的危险成分或有害物质含量依照EIP-A, EIP-B, EIP-C的标准高于SJ/T11363-2006 限定要求。 Indicates that this toxic or hazardous substance contained in all the homogeneous materials for this part, according to EIP-A, EIP-B, EIP-C is above the limit requirement in SJ/T11363-2006.</p>						

WEEE Directive



This equipment is regulated by the European Union under WEEE Directive (2012/19/EU). Refer to www.nordsonefd.com/WEEE for information about how to properly dispose of this equipment.

Ultimus V Features

- Electronically change / adjust dispensing Time, Pressure, and Vacuum
- Simultaneously display dispensing Time, Pressure, and Vacuum
- Auto Increment mode to adjust dispensing parameters after a certain number of shots or a specific lapsed time
- Auto Sequence mode that allows deposit patterns to be repeated automatically
- 400 individual memory storage cells
- Scroll or select cells via front panel keypad or external PC / PLC control
- Switching between Steady, Timed, and Teach modes
- Front panel Manual Cycle key
- Teach function
- Multi-level operator lockout
- Alarm indicators
- End of Cycle Feedback loop
- Soft button data input 0–9 keypad
- Operator control of LCD display brightness
- Easy UP / DOWN arrow key navigation
- External PC interface for data input
- Display cycle counter
- RS-232 interface compatible with standard RS-232 protocol
- ESD-safe via connection with external ESD grounding plug
- 0–7.0 bar (0–100 psi) air regulation range; 0–18 H₂O vacuum regulation range
- Internal universal power supply
- D-sub I/O (15-pin) and communication (9-pin) connections
- Alarm input / output I/O signals



Unpacking the Dispenser

Unpack the contents of the package and lay them out on a clean workbench.

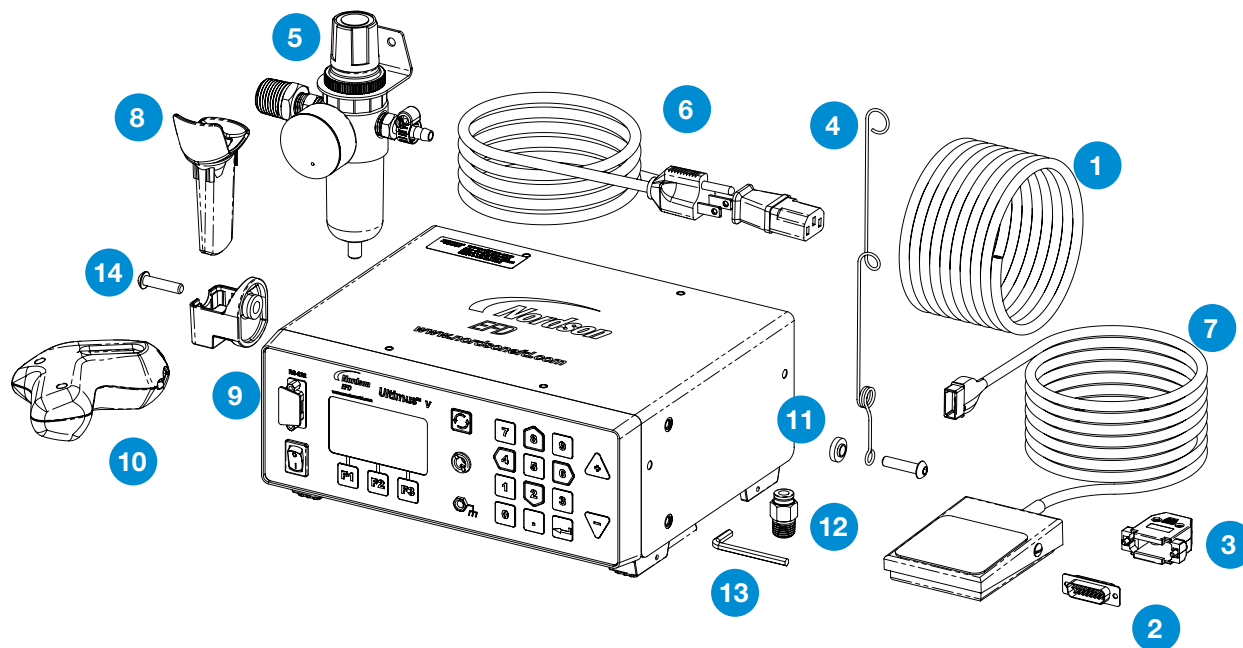

The following items should be included with your Ultimus V dispenser:

1. Tubing — 6 mm OD Blue Urethane
2. Connector 15 Pos Plug D-Sub Solder
3. Backshell 15 Pos D-Sub
4. Hose Support Adapter
5. Filter Regulator
6. Power Cord, American Plug
7. Foot Pedal Assembly
8. Barrel Holder Sleeve
9. Barrel Holder
10. Ergonomic Barrel Holder
11. Hose Support Locating Washer
12. Fitting — 1/4 NPT X 6 mm OD
13. Wrench — Hex Key, 4 mm
14. Screw — M6 X 25 mm, Bh, Blk

(Not Shown)

Literature — Optimum Component Poster

Dot Test Kit Sheet

Box of 50 tip caps

Features and Controls

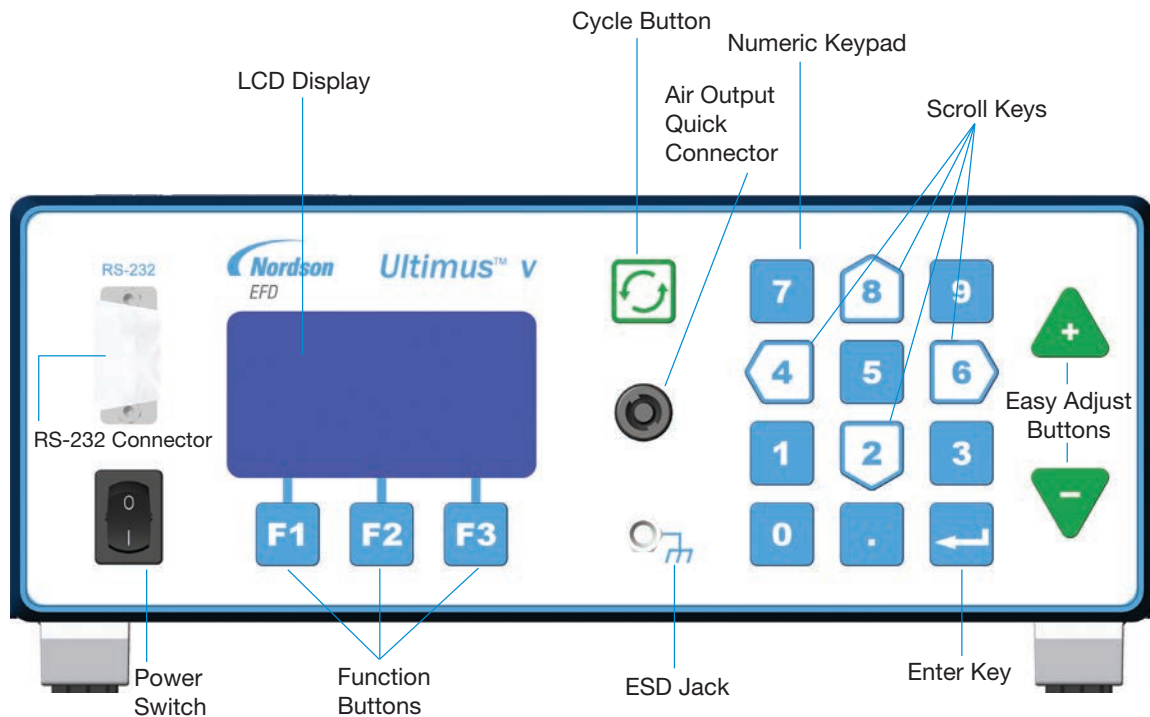

Front Panel

Power Switch: Turns the Ultimus V dispenser on and off.

RS-232 Connector: Allows all dispensing parameters to be modified from a remote PC or PLC.

LCD Display: Shows data and system status as well the current function selected.

Function Buttons: Used to select items shown on the bottom of the LCD display above the individual function buttons. The function of each key depends on the current screen display and / or mode.

Cycle Button: Initiates a dispense cycle.

Air Output Quick Connector: Syringe barrel adapter / Optimeter™ connection.

ESD Jack: Standard 0.166" banana jack allows the user to connect grounding for ESD-sensitive equipment.

Numeric Keypad: Used to enter settings.

Scroll Keys: The arrow-shaped 2,4, 6, and 8 keys on the numeric keypad can be used for cursor scrolling as well as data entry.

Easy Adjust Buttons: Adjusts dispense time or memory cell location.

Enter Key:  Confirms highlighted selection or data entered.

Features and Controls (continued)

Back Panel

Air In: Main filtered air supply input.

6 mm push-in fitting, used to connect main air supply. Minimum 1.0 bar (15 psi) above desired dispensing pressure; maximum 0–7.0 bar (0–100 psi).

Exhaust: Syringe barrel and vacuum air exit port.

6 mm push-in fitting. Output air from the syringe barrel exits from this port at the end of every dispensing cycle. The air consumed by the vacuum generator exhausts through this port as well. The push-in fitting allows tubing to be connected for remote discharge.

Foot Pedal / Finger Switch Connector: Connection for dispenser actuating device.

Connection is for a momentary contact closure switching device. EFD strongly suggests the use of EFD foot pedals and finger switches, which are specifically designed for this application.

RS-232 Connector: (DB-9 Male Style)

Either the front or rear RS-232 port can be enabled at one time. The RS-232 port is selected in the Communication LCD screen.

Any communications to the disabled RS-232 port will be ignored by the dispenser. The RS-232 protocol is covered in Appendix B.

I/O (Input / Output) Connector: (DB-15 Female Style) Used to connect to any input or output.

For detailed pin information, refer to Appendix A.

AC Power Input: Connects dispenser to local power source.

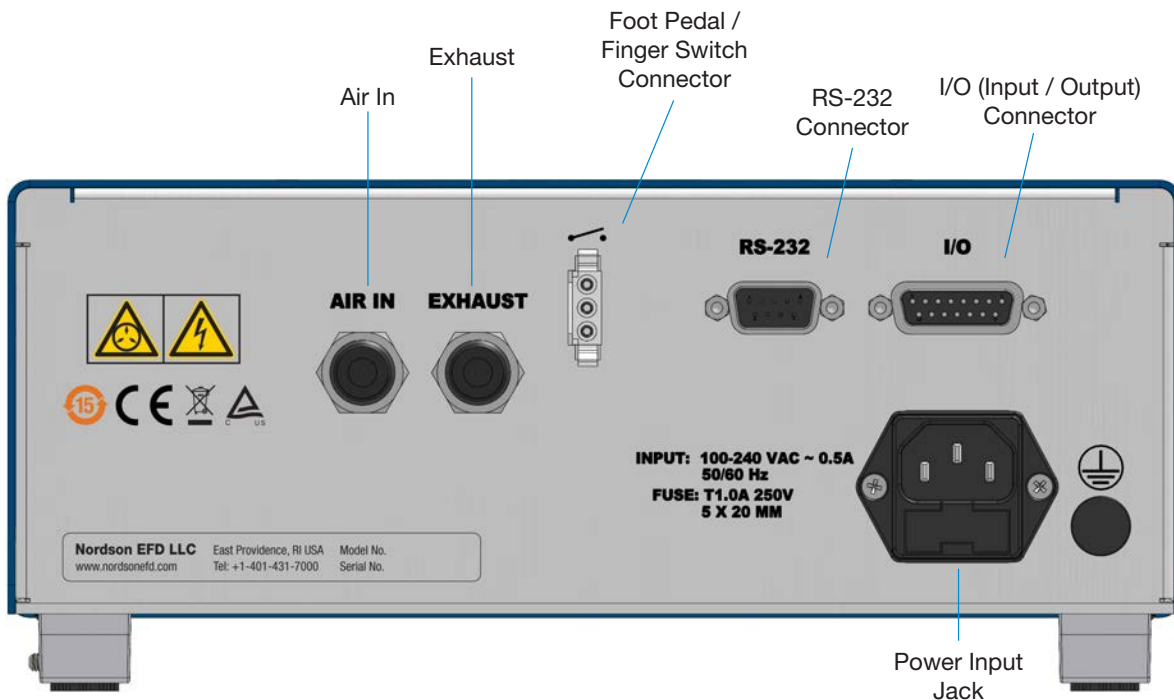

Initial Setup for Testing

Connect Power

1. Connect the power cord to the back of the dispenser.
2. Plug the power cord into your local power source.
3. Turn the power switch on the front panel to the on position.

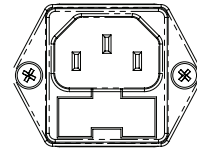

Connect Foot Pedal

The Ultimus V can be operated using the foot pedal provided, or by an external device via a DB-15 connector.

1. Plug the foot pedal into the connector on the back of the dispenser.
2. You can also operate the Ultimus V with an optional finger switch or a 5 to 24 VDC pulse.

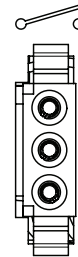

Connect Air Input

NOTE: Clean, dry, filtered factory air is required to meet warranty. To ensure air quality, install the five-micron filter regulator provided with the Ultimus V.

1. Push one end of the air input hose into the Air In fitting on the back of the dispenser.
2. Connect the other end of the air input hose to the filter regulator supplied with the Ultimus V dispenser.

NOTE: Input air should be set at least 1.0 bar (15 psi) — or more — higher than dispensing pressure, up to a maximum of 0–7.0 bar (0–100 psi).

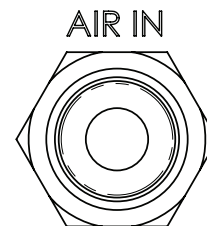

Connect Air Output

Push the connector on the adapter / Optimeter into the connector on the front of the Ultimus V and twist clockwise to lock.

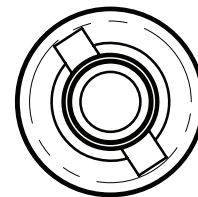

Attach Syringe Barrel and Tip

1. Secure an EFD syringe barrel filled with your fluid to the adapter / Optimeter.
2. Replace the tip cap with an appropriate EFD precision dispense tip.

Dispensing System Setup

Deposit size is controlled by time, pressure and tip size.

Please follow these instructions to test each function. Use the convenient Dot Standards sheet included in your dispensing kit.

Using Steady Mode to Dispense a Dot or Stripe or Fill a Cavity

1. Start with pressure set to zero.
2. Place the syringe barrel over a piece of paper or test surface.
3. Place the unit in “Steady” mode.
4. Unsnap the safety clip. Depress and hold the foot pedal for the remainder of setup.
5. While resting the tip on the paper (test surface), increase the air pressure by 0.069–0.138 bar (1–2 psi) using the keypad until you have reached the desired fluid dispensing flow rate.

NOTE: Always use the lowest possible pressure and the largest possible tip size. The combination of the lowest possible output pressure + largest possible tip size + longest possible dispense duration = most consistent and accurate deposits.

6. Release the foot pedal.
7. Retest the dispensing rate a few more times. Fine tune as required by making small changes in pressure.



Remember — always bring the tip in contact with the work surface at the illustrated angle. After the tip is in position, press the foot pedal. Release pedal and remove tip by lifting straight up.

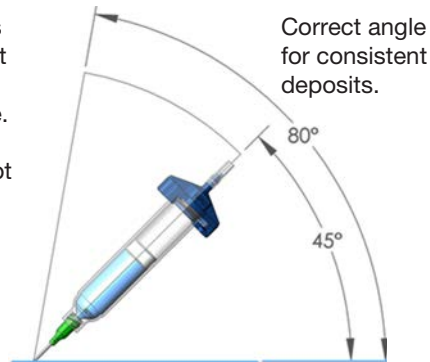

Using Timed Mode to Make Repeatable Deposits

1. Refer to the previous section to purge your dispense tip of air and fill it with fluid.
2. Place the unit into “Timed” mode.
3. Set the dispense time. The dispense time or duration may be set in one of two ways:
 - Using the Up / down Arrows to set time. Refer to the “Features and Controls” section.
 - Using the Program / Teach button to set time. Refer to the “Features and Controls” section.
4. Press the foot pedal / finger switch to activate the dispense cycle. The dispenser will now continuously dispense for the pre-set duration of time. Once the time has expired, the dispenser will stop dispensing and await another triggering signal from the foot pedal / finger switch or signal from the host controller.

NOTE: The foot pedal / finger switch only needs to be pressed for a moment.

If the foot pedal / finger switch or contact closure I/O signal is initiated at any time during the dispense cycle, the dispenser will immediately abort and stop dispensing. This is a unique safety feature to prevent accidental dispensing.

Using the Vacuum Control Feature for Low Viscosity Fluids

The Vacuum Control feature allows you to dispense low viscosity fluids consistently without dripping between cycles. The vacuum overcomes head pressure on the fluid within the barrel, which prevents dripping.

1. Make sure that you have attached an EFD syringe barrel filled with the fluid intended for dispensing, and that the air pressure is set all the way to zero. EFD recommends the use of a Blue LV Barrier piston for watery, low viscosity materials.
 2. Make sure the barrel adapter safety clip is closed.
 3. Remove the tip cap and replace it with an appropriate EFD dispense tip.
 4. Set the air pressure at 0.1 bar (2 psi).
 5. While pointing the tip over a container or resting it on a test surface, release the safety clip on the adapter / Optimeter hose assembly.
 6. Place the dispenser in “Steady” mode. Depress and hold the foot pedal until a drip begins to form at the end of the tip.
 7. Release the foot pedal. At this point, fluid will continue to exit the tip.
 8. Increase the vacuum using the keypad by 0.5 to 1.0 inches of water until the fluid deposit size stabilizes without growing.
- NOTE:** Do not increase the vacuum to the point where the deposit is actually drawn back into the tip or to where bubbles form in the barrel. Excessive vacuum causes inconsistent dispensing.
9. Lift the tip off the test surface, wipe the tip end and retest by pressing the foot pedal momentarily. The deposit should stay at the intended size and not increase or decrease in size. If it does, repeat steps 4–8 to fine-tune the vacuum control.
 10. Once the vacuum is properly set, increase air pressure to the desired production setting before beginning your dispensing process.

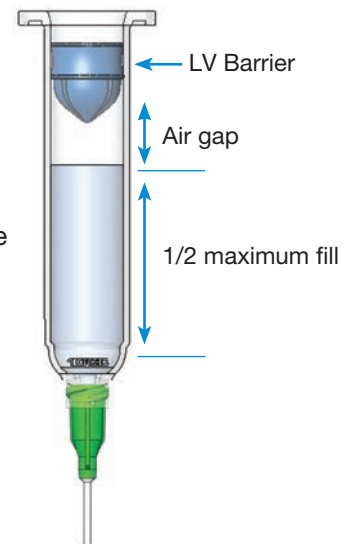

Filling the Syringe Barrel

Caution: Do not completely fill syringe barrels. The optimum fill is a maximum 2/3 of the barrel capacity and 1/2 of the barrel capacity when using the EFD blue LV Barrier™ piston.

For best results, we strongly recommend that you use a piston as part of your dispensing system. The white EFD SmoothFlow piston is appropriate for most fluids and has several advantages.

- First, vacuum adjustment is less sensitive.
- Second, the piston prevents fumes from the fluid being exhausted into the work environment.
- Third, the piston prevents fluid backflow into the dispenser if the syringe barrel is inadvertently turned upside down.
- Fourth, the piston makes it easy and safe to change tips without dripping.

For watery solvents and cyanoacrylates, request the blue EFD LV Barrier piston, available in 3cc, 10cc, and 30 / 55cc sizes. If you are dispensing an RTV silicone and find that the piston bounces and causes stringing, request EFD's assistance in selecting a suitable piston.

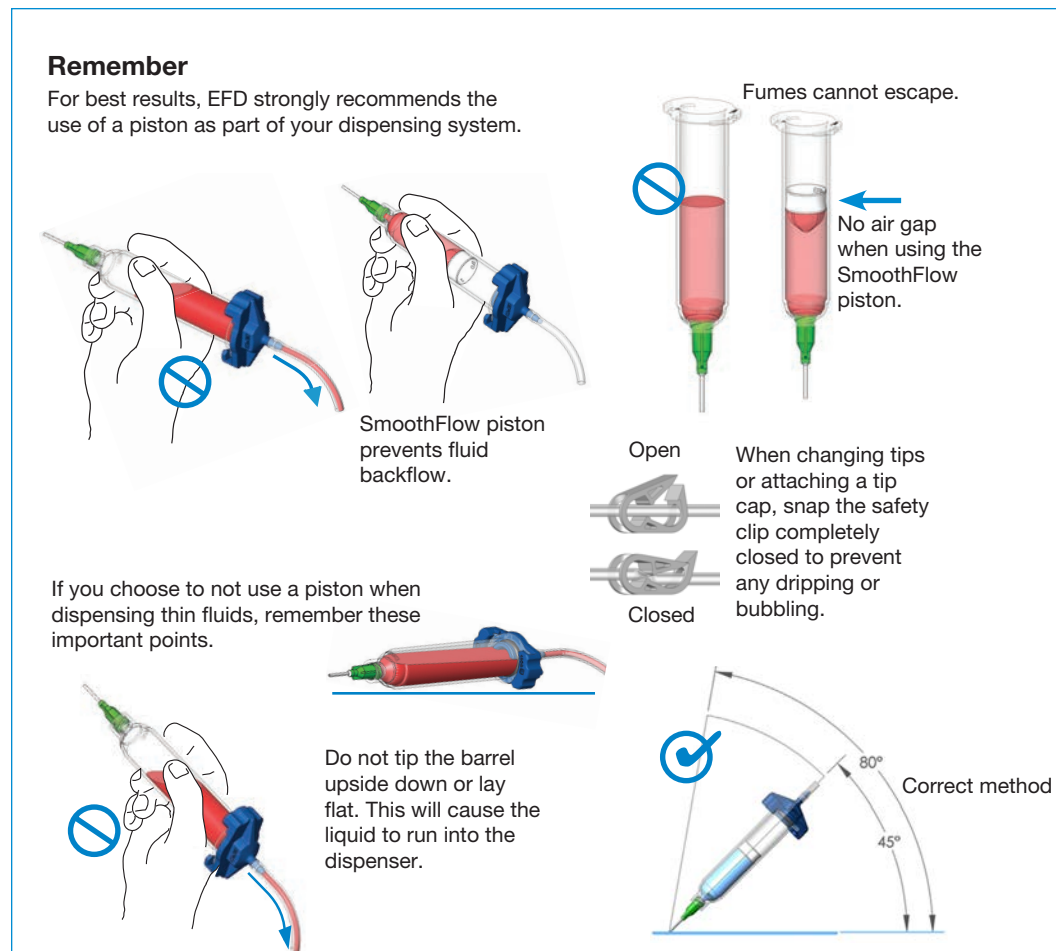

Initial Settings

Dispenser settings and dispensing parameters can be entered manually using the keypad and buttons on the front of the Ultimus V dispenser or, alternatively, by using the Ultimus V Interactive Software. To download the software, visit www.nordsonefd.com/UltimusInteractiveSoftware.

NOTE: To facilitate setup, begin by setting the language in which data will be displayed. Refer to “Setting Language” on page 20.

The following examples show data being entered manually.

- Press the power switch to turn on the dispenser. The Main screen will be displayed and show all the dispensing parameters. The first time the dispenser is powered up, all settings will be preset to zero.

AI	Auto Increment Function
MEM	Current Memory Address
TIME	Dispensing Time
PRES	Dispensing Pressure
VAC	Vacuum
SHOT	Dispense Counter
	Dispensing Status (shown as icons)



Basic Menu Operation

- From the Main screen, press the F3 (Menu) key to display the first Main Menu screen.
- Use the Up / Down (8 / 2) keys to move through the individual menu items.
- Press the Enter key to display the screen for the highlighted item.
- Use the Up / Down (8 / 2) keys to scroll through and select individual items.
- Press the F2 (Save) key to confirm your selection.
- Use the F1 (Previous) and F2 (Next) keys to display the previous / next menu screen.
- Press the F2 (Home) function key to return to the Main screen.
- If a menu item is locked out via the Operator Lockout screen, that menu item will be blanked out and cannot be selected.

Setting the Real Time Clock

Highlight SET CLOCK on the Main Menu screen, then press the Enter key.

- Press the F3 function key to select 12 hour or 24 hour format, then enter the time.

NOTE: A leading zero must be used as required. For example:

Time	12 hour format	24 hour format
5:30 am	05:30 am	05:30
1:30 pm	01:30 pm	13:30

- If 12 hour format is used, Press 1 for am or 2 for pm after entering the time.
- Press the F2 (Save) key to save this setting.



Setting the Date

- Highlight SET DATE on the Main Menu screen, then press the Enter key.
- Enter the date in MM / DD / YY format.
- Press the F2 (Save) key to save this setting.



Setting Units of Pressure

- Highlight UNITS OF PRESSURE on the Main Menu screen, then press the Enter key.
- Use the Up / Down (8 / 2) keys to select the unit type.
- Press the F2 (Save) key to save this setting.



Setting Units of Vacuum

- Highlight UNITS OF VACUUM on the Main Menu screen, then press the Enter key.
- Use the Up / Down (8 / 2) keys to select the unit type.
- Press the F2 (Save) function key to save this setting.



Setting Language

- From the Main screen, press the F3 (Menu) key to display the Main Menu.
- Press the 2 (Down Arrow) button on the keypad until the desired Language is highlighted, then press the F2 (Save) key to confirm your selection.
- Press the F2 key to return to the Main screen, where data will be displayed in the language you just selected.



Setting Operator Lockout Parameters

- From the Main screen, Press the F3 (Menu) key to display the Main Menu Screen.
- Use the Up / Down (8 / 2) keys to highlight OPERATOR LOCKOUT, then press the Enter key.
- The Password screen will be displayed.



NOTE: The Ultimus V dispenser is shipped with the password preset to 0000.

Enter the 4-digit security code, then press the Enter key. An incorrect password will clear the digits and redisplay the dashes.

General Operator Lockout Procedures

The following items can be locked out to prevent unauthorized adjustment:

- | | | |
|--------------------|------------------------|-----------------------|
| • Time Setting | • Dispense Mode | • Pressure Units Menu |
| • Pressure Setting | • Auto Increment Mode | • Vacuum Units Menu |
| • Vacuum Setting | • Auto Increment Reset | • Language Menu |
| • Memory Setting | • Alarm Reset | • Set Comm Menu |
| • Deposit Counter | • Main Menu | • Alarms Menu |

NOTES:

- If a square is checked, it means that item has been locked out and the user cannot change or select that item.
- To lock out an item, press the Up / Down (8 / 2) keys to highlight the desired item. Press the Enter key to toggle the lockout setting on and off.
- Press the F3 (Next) key to load the next Operator Lockout screen. Press the F1 (Previous) key to load the previous Operator Lockout screen. When finished, press the F2 (Save) key to save the settings and return to the Main Menu screen.
- It is also possible to lock out the entire Main Menu so that when the user presses the Menu Function key on the Main screen, the Password screen appears first. When the correct password is entered, the Main Menu screen will load.
- When the Time Setting parameter is locked out, the deposit time duration cannot be adjusted and the Teach dispense mode will also be locked out.
- When the F1 (Dispense Mode) key is locked out, the Ultimus will remain in the current Dispense Mode (Timed or Steady) and cannot be changed.
- Locking out the Set Clock item will also lock out the Set Date item.
- The user can be locked out from resetting the dispensing parameters back to the starting address before the Ultimus V reaches the ending address and the final trigger value by checking the Auto Increment Reset option.
- Resetting the Alarms can be locked out. The user will be asked for the password when a latched alarm is being reset.

Setting a New Password

- Highlight Set Password and press the Enter key.
- When the Password screen appears, enter the new password and press the Enter key.
- When the Please Confirm Operation screen appears, press F1 (Yes) to save the new password or F3 (No) to keep the original password.



Clearing a Password

- Pressing and holding the Enter and 1 keys while the Ultimus V is powering up will reset the security password.
- The Please Confirm Operation screen will appear. Pressing the YES function key will reset the password to "0000" (all zeros). Pressing the NO function key will allow the Ultimus V to continue to power up without resetting the password.

Alarm Options Screen

- The Alarm Input Signal is the signal that is sensed on the Alarm Input pins of the digital I/O connector. The dispenser will not allow any dispense cycles to occur when this signal is active. The Alarm Input Signal is enabled when a check mark is shown in the box next to Enable Input Alarm Signal.
- The Alarm Input Signal can trigger the Alarm Output Signal on the Digital I/O connector. A check mark in the box next to Enable Input Alarm Output Signal indicates the Alarm Output Signal is enabled for Input Alarm Signals.
- The Alarm Input Signal can be latched. When an Alarm Input occurs and it is latched, the user must reset the Input Alarm before the dispense cycle can resume.

To reset the Input Alarm, view the main screen and use the Up / Down (8 / 2) and Left / Right (4 / 6) keys to select the Input Alarm. Pressing the F2 (Reset) key will reset the Input Alarm. A check mark in the box next to Enable Input Alarm Latching indicates that the Alarm Input Latch is enabled.

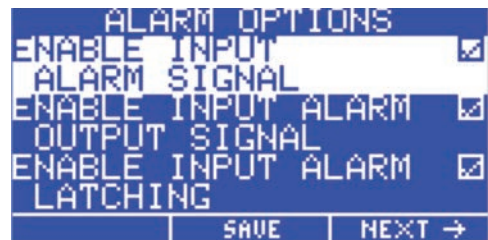

Alarm Options Screen (continued)

- The Pressure Alarm can activate the Alarm Output Signal on the digital I/O connector. A check mark in the box next to Enable Pressure Alarm Output Signal indicates that the Alarm Output signal is enabled for Pressure Alarm signals.
- The Pressure Alarm Signal can be latched. When a Pressure Alarm occurs and it is latched, the user must reset the Alarm before dispense cycles can be resumed. To reset the Pressure Alarm, view the main screen and use the Up / Down (8 / 2) keys and the Left / Right (4 / 6) keys to select the Pressure Alarm. Pressing the F2 (Reset) function key will reset the Pressure Alarm. A check mark in the box next to Enable Pressure Alarm Latching indicates the Pressure Alarm Latch is enabled.
- The Auto Increment Alarm will activate when Auto Increment is active, the memory address is set at the End Address and the dispense count / timer has passed the Trigger value. The Auto Increment Alarm is enabled when a check mark is shown in the box next to Enable Auto Increment Alarm.
- The Auto Increment Alarm can activate the Alarm Output Signal on the digital I/O connector. A check mark in the box next to Enable Auto Inc Alarm Output Signal indicates that the Alarm Output Signal is enabled for Auto Increment Alarms.
- The Auto Increment Alarm is always latched. To reset the Auto Increment Alarm, view the main screen and use the Up / Down (8 / 2) keys and the Left / Right (4 / 6) keys to select the Auto Increment Alarm. The F2 function key will now be labeled "RESET". Pressing the F2 function key will reset the Auto Increment Alarm.

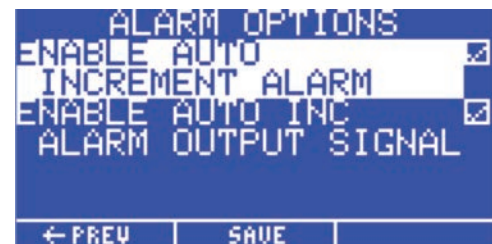

Communications Port Options Screen

- The Communications Port settings screen allows the user to select which RS-232 port is active. The firmware will not allow both ports to be enabled at the same time.
- Pressing the Enter key when Baud Rate is selected will display the Baud Rate selection screen.
- Pressing the F2 (Save) key will store the communications port settings.



Contrast Control

- The LCD contrast can be adjusted from 0 to 63 levels. As the contrast ratio is adjusted up or down, the LCD will automatically adjust to the new ratio.
- The Easy Adjust buttons {Plus (+) / Minus (-) arrow keys} will increase or decrease the LCD contrast ratio. The F2 (Save) key will store the LCD Contrast settings.



Information Screen

- The information screen displays the SAP part number for the dispenser and the name Ultimus V. The Technical Support phone number and web address are also displayed.
- VER: is the version number of the Main board firmware.



Setting Dispense Time, Pressure, And Vacuum

Shot size is determined by a combination of dispense time, air pressure, vacuum (to prevent dripping when dispensing thin fluids) and tip size.

Selecting a Memory Cell

Memory cells can be selected on the Main screen as follows:

- Use the Up / Down (8 / 2) or Left / Right (4 / 6) keys to highlight the MEM field.
- Press the Enter key, enter the 3-digit cell number (000–399), and press the Enter key again.

OR

- Use the Easy Adjust buttons to increase or decrease the cell number.

NOTE: Changing to a different memory cell will display the dispense time, pressure, vacuum and trigger settings stored in that cell and set the regulator to those pressure and vacuum settings. Any changes to time, pressure or vacuum while in a specific cell will automatically replace the current settings.

Dispense Modes

Timed Mode

This mode is used when the desired dispense time is known.

- Use the Up / Down (8 / 2) or Left / Right (4 / 6) keys to highlight the MEM, TIME, PRES or VAC field.
- Press the F1 key to cycle through the dispensing modes (TIMED -> STEADY -> TEACH -> TIMED) until TIMED is displayed and the TIME field is highlighted.
- Press the Enter key to display the Time entry screen. Enter the dispense time, then press the Enter key to save.

OR

- Use the Easy Adjust buttons to increase or decrease dispense time.

Teach Mode

Teach Mode allows you to set the desired deposit size based on physical observation.

- Press the F1 key until TEACH is displayed, then press the F2 (Reset) key to set dispense time to all zeros.
- Press the foot pedal or the Cycle button until the desired deposit size is achieved, then release the pedal or button. The elapsed dispense time will be displayed in the TIME field.
- Pressing the foot pedal or button again will add to the elapsed dispense time. To reset dispense time and start over, press the F2 (Reset) button.
- Press the F3 key to Save the time setting.

Dispense Modes (continued)

Steady Mode

In Steady mode, the timer is not used. Instead, the unit continues to dispense as long as the foot pedal or Cycle button is pressed.

Setting Pressure

Pressure must be entered using the numeric keypad.

- Use the Up / Down (8 / 2) and Left / Right (4 / 6) keys to highlight the PRES field.
- Press the Enter key, enter the desired pressure, and press the Enter key again to save the setting.

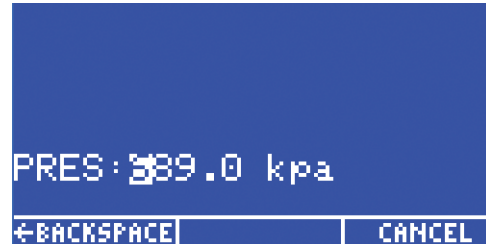

Setting Vacuum

Vacuum must be entered using the numeric keypad.

- Use the Up / Down (8 / 2) and Left / Right (4 / 6) keys to highlight the VAC field.
- Press the Enter key, enter the desired vacuum, and press the Enter key again to save the setting.



Using Auto Increment Mode

The Ultimus V dispenser features an Auto Increment mode that can be set up to automatically adjust dispense time, pressure and vacuum settings when dispensing fluids that change viscosity over time. There are 400 unique memory locations in which different combinations of dispense time, pressure, and vacuum settings can be stored.

Four Auto Increment modes are available:

- **Off.** Auto Increment is not enabled.
- **Dispense Count Mode.** Automatically adjusts settings to compensate for viscosity changes by moving to the next memory cell, based on the number of dispensing cycles.
- **Time Mode.** Automatically adjusts settings to compensate for viscosity changes by moving to the next memory cell, based on the number of seconds that have elapsed.
- **Auto Sequence mode.** Similar to Dispense Count mode except that the memory cell address automatically resets and continues from the start once the end is reached.

To choose an Auto Increment mode:

- Use the Up / Down (8 / 2) and Left / Right (4 / 6) keys to highlight the AI field.
- Pressing the F1 key will cycle through the AI modes. OFF -> COUNT -> TIMED -> SEQUENCE -> OFF.

When Auto Increment mode is enabled in Dispense Count Mode, Time Mode or Auto Sequence Mode, three variables become available on the main LCD screen: Start Address, End Address and Trigger. Each of these variables can be selected and updated either directly with the key pad, or by using the Easy Adjust Increase / Decrease keys. When Auto Increment mode is disabled, the Start Address, End Address and Trigger are not displayed on the LCD.

- **Start Address.** The memory cell address at which Auto Increment mode begins.
- **End Address.** The last memory cell address that will be set before Auto Increment ends.
- **Trigger.** The number of dispensing cycles or the time that elapses before the memory cell address is increased to the next address. Each memory cell has its own trigger value. Therefore, as the memory cell address increases, a new trigger value is loaded for that memory cell. **Any changes to the trigger value while in a specific memory cell will automatically save the trigger value to that memory cell.**

Using Auto Increment Mode (continued)

Dispense Count Mode

Enabling Auto Increment in Dispense Count mode allows the Ultimus V to increase the memory cell address from the Start Address to the End address based on the number of dispense cycles that occur.

The Shot variable on the main screen tracks the number of dispense cycles for the current memory address and resets to zero when the memory cell address advances to the next address.

In Count mode, the Trigger value represents the number of dispense cycles that need to occur before the current memory cell is advanced to the next location. The valid range is 00001 to 99999 dispense cycles. The total dispense cycle count for the unit is saved and will continue to increment while in Auto Increment mode.

Time Mode

Enabling Auto Increment in Time Mode will allow the Ultimus V to increment the memory cell address from the Start Address to the End Address, based on the number of seconds that have elapsed.

When Time mode is selected, the real time clock becomes a counter that counts, in seconds, from 00000 to 99999. The counter resets to all zeros when the memory cell address increments.

In Time mode, the Trigger value represents the amount of time that needs to elapse before the current memory cell is advanced to the next location. The valid range is 00001 to 99999 seconds.

Auto Sequence Mode

Enabling Auto Increment in Auto Sequence mode allows the Ultimus V to increase the memory cell address from the Start Address to the End address based on the number of dispense cycles that occur.

The Shot variable on the main screen tracks the number of dispense cycles for the current memory address and resets to zero when the memory cell address advances to the next address.

As in Count mode, the Trigger value represents the number of dispense cycles that need to occur before the current memory cell is advanced to the next location. The valid range is 00001 to 99999 dispense cycles. The total dispense cycle count for the unit is saved and will continue to increment while in Auto sequence mode.

Once the trigger value is reached for the End address, the Ultimus V will automatically reset the memory cell address back to the Start address and continue increasing the memory cell address as before. The auto increment alarm will not be set in this mode.

Using Auto Increment Mode (continued)

Sample Memory Cell Settings

NOTES:

- When dispensing fluids that change viscosity, it is generally better to set Auto Increment to Time instead of Count.
- Within the individual memory cells, it is preferable to leave the dispense time the same, and only change the pressure from cell to cell in order to maintain the same cycle rate.
- It is recommended to use small pressure adjustments or allow some settling time to ensure consistent deposit amounts.

Cell 0 — Set initial parameters to produce the desired dot size. For example: 20 psi pressure, 0.150 seconds dispense time, 0 vacuum. Set the trigger value to 900 (15 minutes).

Cell 1 — Increase pressure to 23 psi, keep 0.150 seconds dispense time, 0 vacuum. Set the trigger value to 900 (15 minutes).

Cell 2 — Increase pressure to 27 psi, keep 0.150 seconds dispense time, 0 vacuum. Set the trigger value to 900 (15 minutes).

Cell 3 — Increase pressure to 32 psi, keep 0.150 seconds dispense time, 0 vacuum. Decrease the trigger value to 540 (9 minutes).

Cell 4 — Increase pressure to 37 psi, keep 0.150 seconds dispense time, 0 vacuum. Set the trigger value to 540 (9 minutes).

Cell 5 — Increase pressure to 45 psi, keep 0.150 seconds dispense time, 0 vacuum. Set the trigger value to 540 (9 minutes).

Cell 6 — Increase pressure to 55 psi, keep 0.150 seconds dispense time, 0 vacuum. Decrease the trigger value to 360 (6 minutes).

Cell 7 — Increase pressure to 65 psi, keep 0.150 seconds dispense time, 0 vacuum. Decrease the trigger value to 180 (3 minutes).

Cell 8 — (last cell) — Increase pressure to 80 psi, keep 0.150 dispense time, 0 vacuum. Decrease the trigger value to 120 (2 minutes).

If the Auto Increment Alarm is enabled in the Alarm Options screen, the Auto Increment alarm will engage and further dispensing cycles will be stopped. If the Auto Increment Alarm is disabled, the timer will continue to increment and dispense cycles will still be allowed — however, the memory cell address will no longer advance, and will remain at the End Address settings.

NOTES:

- Setting the parameters in the cells needs to be done only one time. When the material reaches the end of its working life, simply replace it with a full syringe and use the same preset parameters.
- To start over, highlight AI, then press F2 (Reset). If the AI Alarm is used, resetting the alarm will also reset the AI mode.

Part Numbers

Part #	Description
7012590	Ultimus V dispenser, 0-100 psi (0-7 bar)
7012589	Ultimus V dispenser, calibrated*, 0-100 psi (0-7 bar)

*Calibrated to EFD specifications based on NIST standards.

Accessories

See the Dispenser Accessories data sheet for a complete list of optional accessories that will maximize the performance of your dispenser. Visit www.nordsonefd.com/DispenserAccessories for details.

Replacement Parts

Ultimus V

1	Bezel and Overlay Ultimus V	7014544
2	High Pressure Transducer Ultimus V	7014545
3	Low Pressure Transducer Ultimus V	7014546
4	Power Switch Ultimus V	7014547
5	Power Supply Ultimus V	7014548
6	Base Manifold Ultimus V	7014549
7	Main PC Board Ultimus V	7014550
8	Cable Front RS-232 Ultimus V	7014551
9	Ultra 2800 Replacement Fuses	7017255
10	Connector Ultimus V I/O 15pos D-Sub	7014553
11	Backshell Ultimus V I/O 15 Pos D-Sub	7014554
12	Fill Valve Ultimus V	7014555
13	Dispense Valve Ultimus V	7014556
14	Proportional Valve Ultimus V	7014557
15	PCB CONTROL Ultimus V	7015394

Replacement Parts (continued)

Ultimus V (continued)

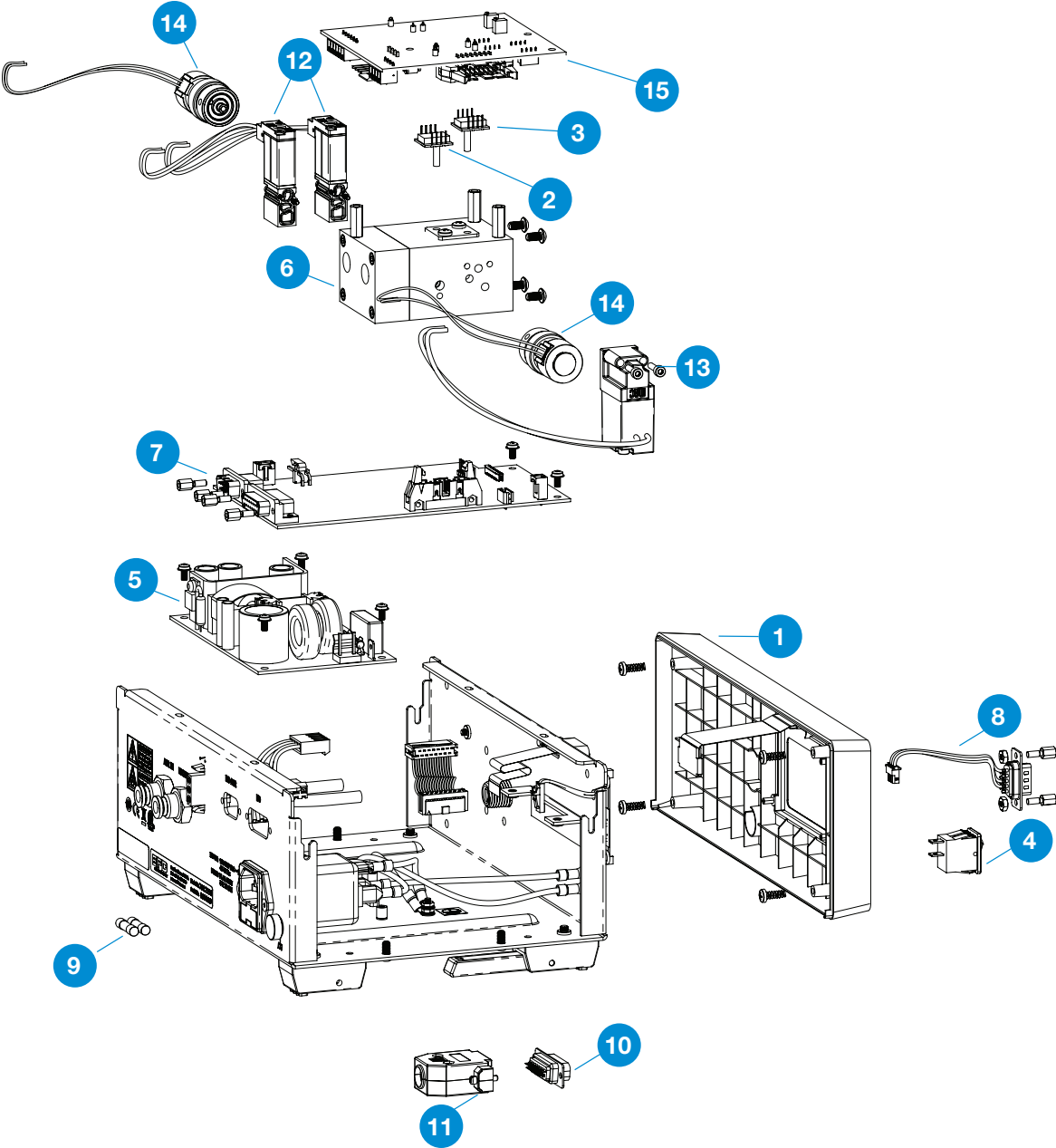

Replacement Parts (continued)

Optimeter

1	Pin Optimeter 10cc Std 5 Pack	7014561
2	Pin Optimeter 30cc Std 5 Pack	7014562
3	Barrel Lock 10cc Optimeter	7014566
4	Barrel Lock 30cc Optimeter	7014567
5	Kit Detent Optimeter	7014568

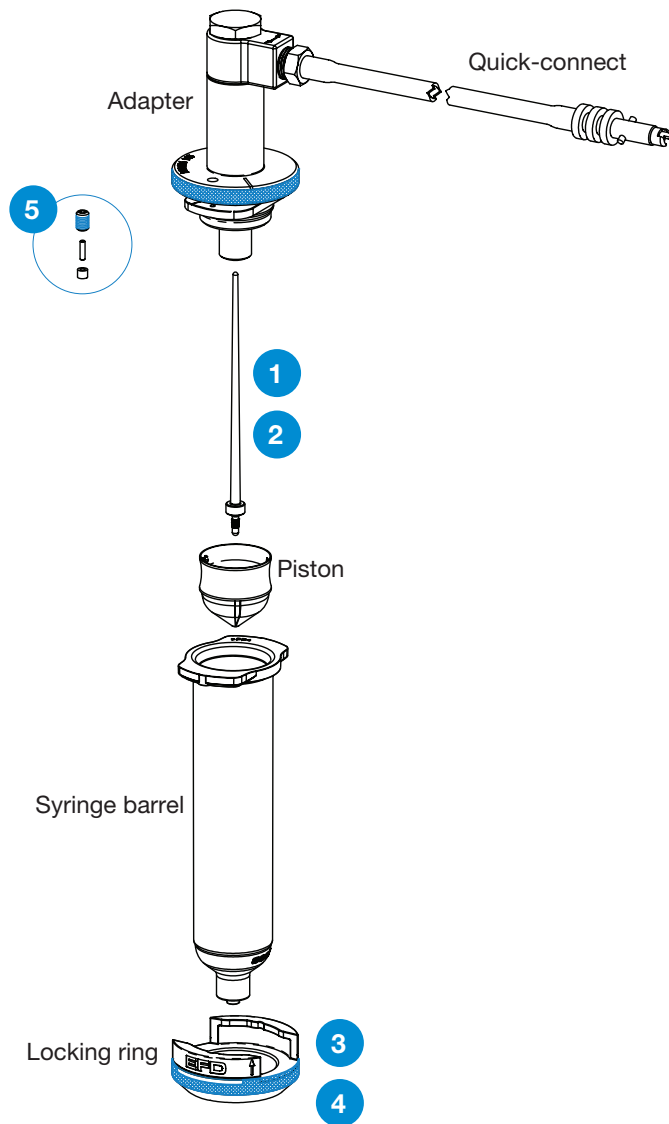

Appendix A – I/O Connector Pin Descriptions

Pin 1: VI+

Voltage Initiate+: This pin is the positive side of a Voltage Initiate signal.

Pin 2: VI-

Voltage Initiate-: This pin is the return of the Voltage Initiate signal.

The Voltage Initiate signal will trigger a dispense cycle when a 5 to 24 VDC signal appears across these pins. An internal 1.2K resistor will limit the Voltage Initiate signal current to 20mA or less. The signal can be momentary (no less than 10ms) or maintained. A new dispense cycle will begin once the 5 to 24 VDC signal is removed and then applied again.

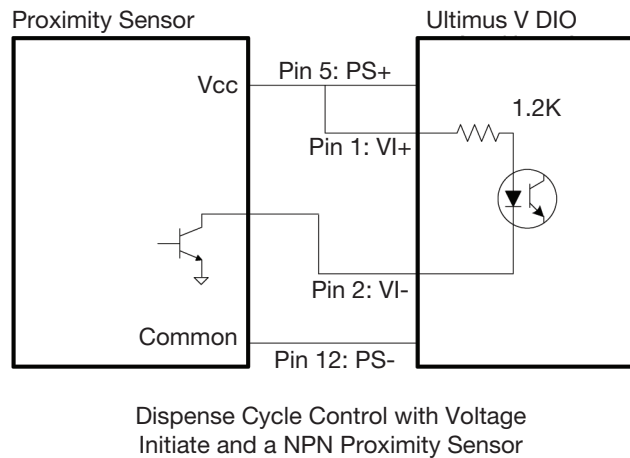
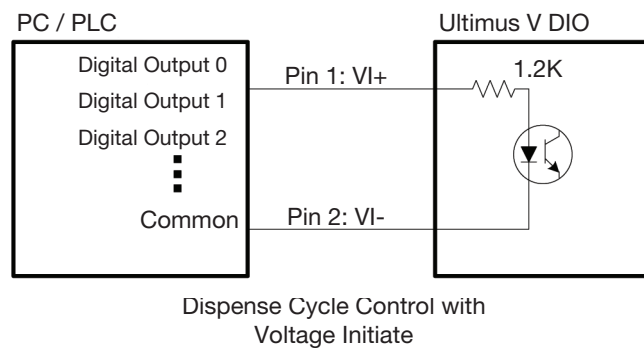

Pin 3: EOCF+

End of Cycle Feedback+: This is the positive input signal for the End of Cycle Feedback solid state switch.

Appendix A – I/O Connector Pin Descriptions (continued)

Pin 4: EOCF–

End of Cycle Feedback–: This signal is the output of a solid state switch.

Upon completion of a dispense cycle, a solid state switch closes and remains closed until the next dispense cycle. The End Of Cycle Feedback circuit can be used to signal back to a host computer, start another device in sequence or initiate other operations that need to be tied into the completion of the dispense cycle.

The circuit is designed to operate between 5 to 24 VDC with a 100 mA maximum current.

NOTE: A resistor should be placed between the external power source and the EOCF+ pin to limit the current through the EOCF circuit to less than 100 mA.

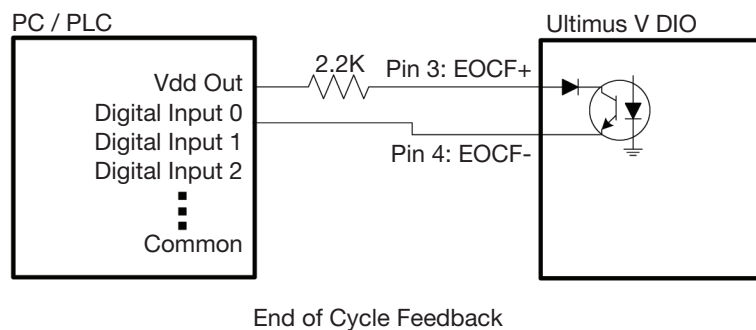

Pin 5: PS+

24VDC Power Supply+: This pin will provide 24 VDC, 100mA power to an external load.

Pin 6: CC Init

Contact Closure Initialization: This pin senses a relay or switch closure. Once a closure is sensed, the dispenser initiates a dispense cycle depending on the operating mode. An internal 1.2K resistor will limit the Contact Closure Initiate signal current to 20mA or less. The contact closure can be momentary or maintained in a steady mode. A new cycle can be initiated by opening and then closing the contact again.

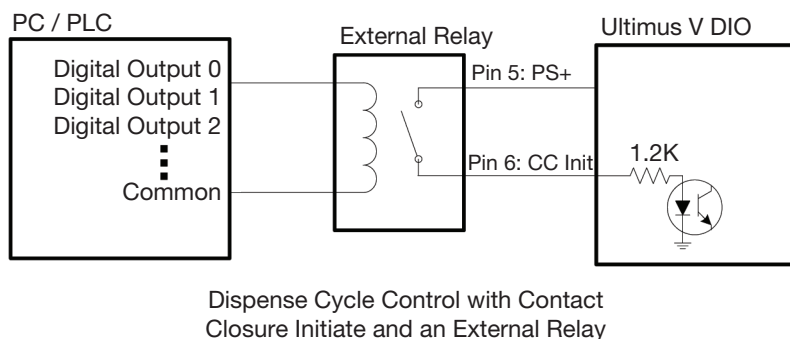

Appendix A – I/O Connector Pin Descriptions (continued)

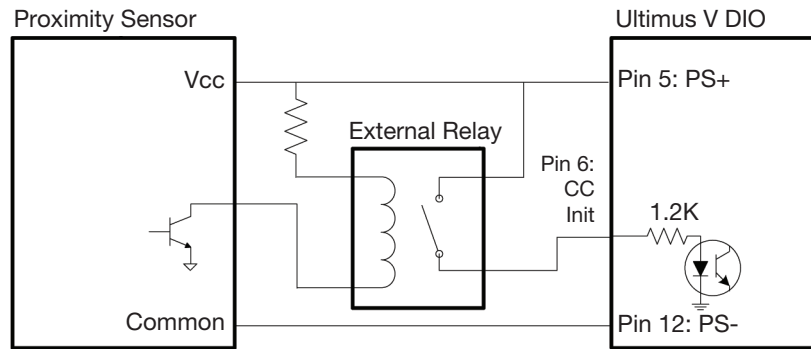

Dispense Cycle Control with Contact Closure Initiate,
NPN Proximity Sensor, and an External Relay

Pin 7: PS+

24VDC Power Supply+: This pin will provide 24 VDC, 100mA power to an external load.

Pin 8: Alarm In

Alarm Input: This pin senses a relay or switch closure. Once a closure is sensed, the dispenser will display the Input Alarm Indicator and prevent any further dispense cycles from initializing. An internal 1.2K resistor will limit the Alarm Input signal current to 20mA or less. This signal can be disabled in the Alarm Options LCD screen.

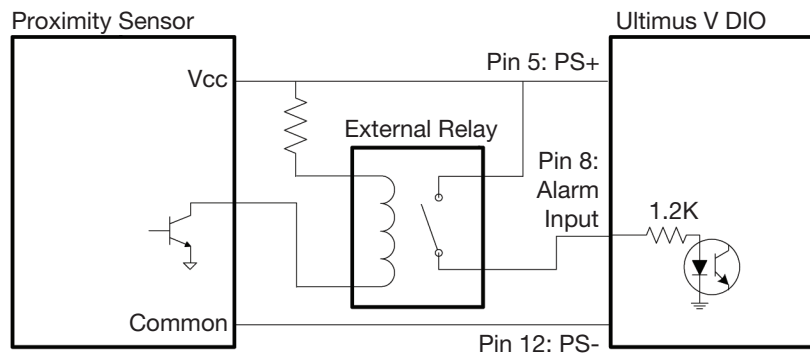

Alarm Input, NPN Proximity Sensor,
and an External Relay

Pin 9: Alarm Out+

Alarm Output+: This is the positive input signal for the Alarm Output solid state switch.

Appendix A – I/O Connector Pin Descriptions (continued)

Pin 10: Alarm Out-

Alarm Output-: This signal is the output of a solid state switch.

The Alarm Out signal is connected by a solid state switch. When an alarm condition occurs, the dispenser closes the solid state switch, shorting out the Alarm Out pins.

The Alarm Out signal can be activated by the Input Alarm, Pressure Alarm or Auto Increment Alarm. The Alarm Options LCD screen is used to allow or disallow any of the alarm conditions from activating the Alarm Out signal.

The circuit is designed to operate between 5 to 24 VDC with a 100mA maximum current.

NOTE: A resistor should be placed between the external power source and the Alarm Out+ pin to limit the current through the Alarm Output circuit to less than 100mA.

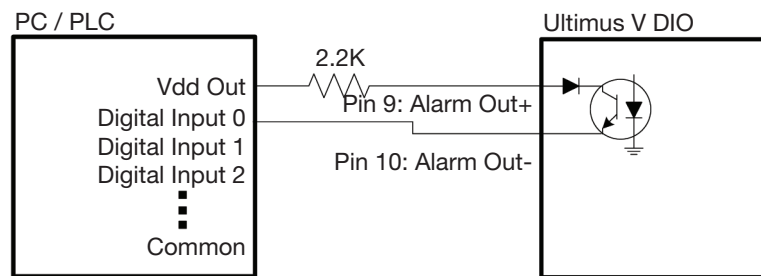

Alarm Output to Digital Input

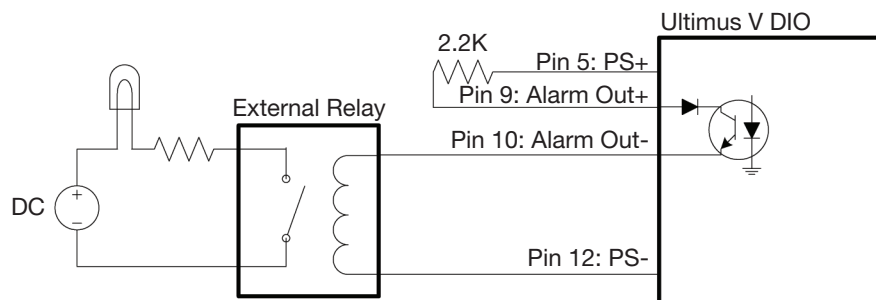

Alarm Output to External Indicator

Pin 11: PS+

24VDC Power Supply+: This pin will provide 24 VDC, 100mA power to an external load.

Pin 12 to Pin 15: PS-

24VDC Power Supply-: These pins are the 24 VDC power supply reference and return pins.

Appendix B — RS-232 Connection Protocol

Pin 2: RS-232_TX

The RS-232 TX pin transmits data from the dispenser to an external communication device. The external communication device should connect this pin to its RS-232 RX pin.

Pin 3: RS-232_RX

The RS-232 RX pin receives data from the external communication device into the dispenser. The external communication device should connect this pin to its RS-232 TX pin.

Pin 5: Common Ground

1. RS-232 Protocol

1.1 Communication Specifications

The RS-232 protocol for the Ultimus V uses the RS-232C standard. The Ultimus V acts as a terminal to the remote host PC or PLC.

The Ultimus V communicates using the following settings:

- Synchronous Mode: Half Duplex
- Baud Rates: 9600, 19200, 38400, 115200 (default)
NOTE: Baud Rate is selectable through the Comm Port Settings menu. Refer to “Communications Port Options Screen” on page 24 for more information.
- Start Bit: 1
- Data Length: 8bit (ASCII)
- Parity Bit: None
- Stop Bit: 1

1.2 Data Codes

All command packets passed between the Ultimus V and the remote host will be formatted in ASCII.

The following ASCII codes are used as part of the communication protocol:

- Packet Start: STX (0x02h)
- Packet End: ETX (0x03h)
- Acknowledge: ACK(0x06h)
- Not Acknowledge: NAK (0x15h)
- Enquiry: ENQ (0x05)
- End Of Transmission: EOT (0x04h)

Appendix B – RS-232 Connection Protocol (continued)

1.3 Communication Sequence

There are two communication sequences that the Ultimus V uses. The first is a download command sequence and the other is a feedback command sequence.

1.3.1 Download Commands

The Download commands are used when the Remote Host sets a parameter on the Ultimus V but does not require feedback data. The download command sequence follows the steps listed below.

1. The Host transmits an Enquiry (ENQ) command to the Ultimus V.
2. The Ultimus V receives the ENQ and transmits an Acknowledge (ACK) back to the host.
3. When the Host receives the ACK, the Host will send the command packet.
STX+08+PS--+0500+F0+ETX for example.
4. When the Ultimus V receives the command packet and the command was successfully executed, the Ultimus V transmits an "A0" command.
If there was an error in the command packet, or the command could not be executed, or the transmission was interrupted and timed out, the Ultimus V will transmit an "A2" command. Refer to "1.4 Communication Timeout" on page 40 for details.
5. After the host receives either an A0 or A2 command, the host can either transmit another command packet or the host can transmit an End of Transmission (EOT) command to end the sequence.

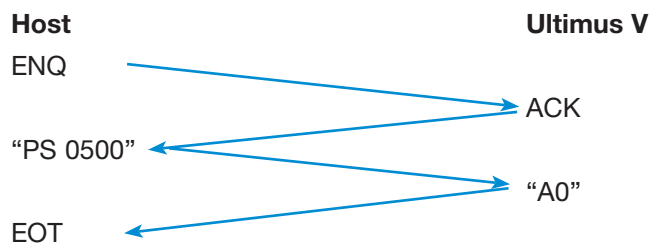

Appendix B — RS-232 Connection Protocol (continued)

1.3.2 Feedback Command

The Ultimus V will send requested data back to the Host when feedback commands are used.

The feedback command sequence follows the steps listed below.

1. The Host transmits an Enquiry (ENQ) command to the Ultimus V.
2. The Ultimus V receives the ENQ and transmits an Acknowledge (ACK) back to the host.
3. When the Host receives the ACK, the Host will send the command packet.
STX+04+UA +C6+ETX for example.
4. When the Ultimus V receives the command packet, the Ultimus V transmits an “A0” command.
If there was an error in the command packet, or the command could not be executed, or the transmission was interrupted and timed out, the Ultimus V will transmit an “A2” command. Refer to “1.4 Communication Timeout” on page 40 for details.
5. If the host receives an “A0” command, the host will send an ACK to indicate that it is ready to receive data.
6. When the ACK from the Host is received, the Ultimus V will send a command packet that contains the data requested by the host. STX+05+D0+00001+96+ETX for example.
7. Once the host receives the command packet, the host can either transmit another command packet or the host can transmit an End of Transmission (EOT) command to end the sequence.

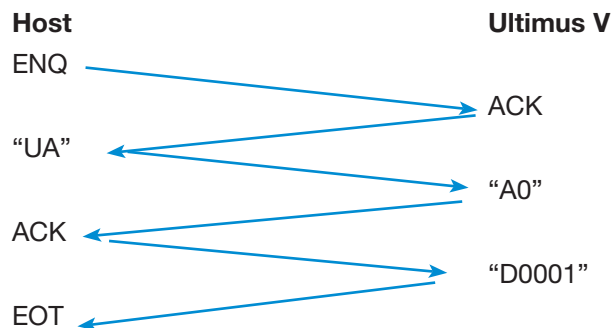

Appendix B — RS-232 Connection Protocol (continued)

1.4 Communication Timeout

To ensure that RS-232 packets do not compromise the operation of the LCD display, the Ultimus V has a Communication Timeout safeguard. As soon as the Ultimus V receives the ACK (Acknowledge) input from the host, the LCD enters a communication-hold state and awaits commands. If no command is received after 3 seconds, the Ultimus V sends an “A2” failure command to the host and removes the communication hold. Any characters received by the Ultimus V will reset the timeout.

1.5 Command Packet Format

Each command packet will contain the following information and will be formatted as shown below:

[STX] [No. of Byte] [Command] [Data] [Checksum] [ETX]

1.5.1 STX

Every command packet will begin with the Start of Packet (0x02h) ASCII character.

1.5.2 No. of Bytes

The number of bytes part of the command packet is the sum of the characters in the Command and Data parts of the command packet. This value is expressed as a 2-digit hexadecimal from 0x04h to 0xFFh. The hexadecimal value is encoded as ASCII characters.

1.5.3 Command

The Command part of the Command Packet is next. The list of available commands is listed in the next section. The command part is four characters long. If the command does not contain four characters, the remaining characters should be the ASCII space character (0x20h). The command is transmitted in ASCII characters.

1.5.4 Data

The Data part follows the Command. The Data can be from 0(0x00h) to 251(0xFB) characters long. This length is dependent on the command. The Data is transmitted in ASCII characters.

1.5.5 Checksum

The checksum is the next part of the command packet. The checksum is a form of error checking the command packet. The checksum is calculated by subtracting the actual value of each ASCII byte (“0” in ASCII is 0x20 in hex, 32 in decimal) from zero (0x00h). The resulting negative value’s least significant byte is the checksum value.

Each byte (ASCII character) starting with No. of Bytes (1.5.2) through Data (1.5.4) is used to calculate the checksum. Converting the least significant byte (2 digits in hex) to ASCII characters and appending them to the rest of the command packet provides the checksum value. If the checksum is incorrectly calculated, the Ultimus V responds with a Failure Command (“A2”).

The checksum can also be understood as:

$$\text{Checksum} = 0 - \sum_{0}^n \text{bytes [n]}$$

Where “n” = the number of bytes

Appendix B — RS-232 Connection Protocol (continued)

1.5.6 ETX

The final part of the command packet is the End of Packet (0x03h) ASCII character.

The following is an example of a command packet. This example uses the Pressure Set Command (“PS”) to send a 50.0 psi value to the Ultimus V.

The command:

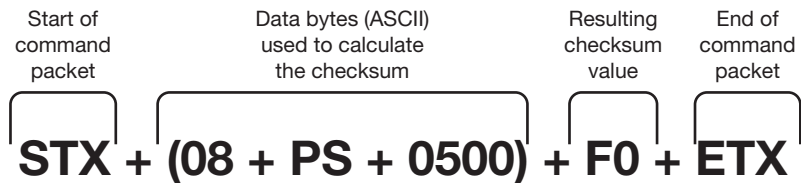

The ASCII Codes:

0x02h (STX) + 0x30h (“0”) + 0x38h (“8”) + 0x50h (“P”) + 0x53h (“S”) + 0x20h (“ ”) + 0x20h (“ ”) + 0x30h (“0”) + 0x35h (“5”) + 0x30h (“0”) + 0x30h (“0”) + 0x46h (“F”) + 0x30h (“0”) + 0x03h (ETX)

2. RS-232 Commands

The following is a list of the RS-232 commands for the Ultimus V. Each item will give a brief description of the command, command format with a description of the data that is attached to the command, and if necessary, the format of the return command along with a description of its attached data. A dash “-” represents an ASCII space value (0x20h).

2.1 Protocol Commands

These commands are used to communicate command success or failure between the remote host and the Ultimus V.

2.1.1 Success Command

This command will be sent if a command was successfully executed.

Format: A0

2.1.2 Failure Command

This command will be sent if a command failed to execute. This could be caused by an error in the command packet or because the transmission of the command packet was interrupted and thus timed out.

Format: A2

Appendix B — RS-232 Connection Protocol (continued)

2.2 Download Commands

These commands are only from the host to the dispenser. The dispenser does not return any data.

2.2.1 Memory Change Command

This command changes the selected memory location of the dispenser. The LCD screen will update to the new memory location, including updating the dispense time, pressure and vacuum parameter.

Host Format: CH--ccc

ccc: The 3-digit memory location from 0–399. The dispenser will automatically limit value to prevent any errors.

2.2.2 Timed Mode Command

This command switches the dispenser into timed mode.

Host Format: TT--

2.2.3 Steady Mode Command

This command switches the dispenser into steady mode.

Host Format: MT--

2.2.4 Time / Steady Toggle Command

This command toggles the dispenser between Timed mode and Steady mode.

Host Format: TM--

2.2.5 Pressure Set Command

This command updates the pressure value in the current memory location

Host Format: PS--pppp

pppp: The 4-digit pressure setting excluding the decimal point. This is a unitless value. The valid pressure ranges and decimal point are determined by the pressure units currently selected in the dispenser.

2.2.6 Memory-Pressure Set Command

This command updates the pressure value in the memory location specified in the command. This command will update the LCD screen to the specified memory location.

Host Format: PH--CHcccPpppp

ccc: The 3-digit memory location from 0–399. The dispenser will automatically limit value to prevent any errors.

pppp: The 4-digit pressure setting, excluding the decimal point. This is a unitless value. The valid pressure ranges and decimal point are determined by the pressure units currently selected in the dispenser.

Appendix B — RS-232 Connection Protocol (continued)

2.2.7 Vacuum Set Command

This command updates the vacuum value in the current memory location.

Host Format: VS--vvvv

vvvv: The 4-digit vacuum, setting excluding the decimal point. This is a unitless value. The valid vacuum ranges and decimal point are determined by the vacuum units currently selected in the dispenser.

2.2.8 Memory-Vacuum Set Command

This command updates the vacuum value in the memory location specified in the command. This command will update the LCD screen to the specified memory location.

Host Format: VH--CHcccVvvvv

ccc: The 3-digit memory location from 0–399. The dispenser will automatically limit value to prevent any errors.

vvv: The 4-digit vacuum setting, excluding the decimal point. This is a unitless value. The valid vacuum ranges and decimal point are determined by the vacuum units currently selected in the dispenser.

2.2.9 Time Set Command

This command updates the dispense time value in the current memory location.

Host Format: DS--Ttttt

tttt: The 4- or 5-digit dispense time value, excluding the decimal point. The valid range is 0.0000 to 9.9999. This command accepts either 3 or 4 decimal places.

2.2.10 Memory-Time Set Command

This command updates the dispense time value in the memory location specified in the command. This command will update the LCD screen to the specified memory location.

Host Format: DH--CHcccTtttt

ccc: The 3-digit memory location from 0–399. The dispenser will automatically limit value to prevent any errors.

tttt: The 4- or 5-digit dispense time value, excluding the decimal point. The valid range is 0.0000 to 9.9999. This command accepts either 3 or 4 decimal places.

2.2.11 Memory-Time-Pressure-Vacuum Set Command

This command updates the dispense time, dispense pressure and vacuum values in the memory location specified in the command. This command will update the LCD screen to the specified memory location.

Host Format: EM--CHcccTttttPppppVvvvv

ccc: The 3-digit memory location from 0–399. The dispenser will automatically limit value to prevent any errors.

tttt: The 5-digit dispense time value excluding the decimal point. The valid range is 0.0000 to 9.9999.

pppp: The 4-digit dispense pressure value excluding the decimal point. The valid pressure ranges and decimal point are determined by the pressure units currently selected in the dispenser.

vvvv: The 4-digit vacuum value excluding the decimal point. The valid vacuum ranges and decimal point are determined by the vacuum units currently selected in the dispenser.

Appendix B — RS-232 Connection Protocol (continued)

2.2.12 Pressure Units Set Command

This command sets the units the dispenser is using to display pressure.

Host Format: E6--uu

uu: The pressure units. 00 = PSI, 01 = BAR, 02 = KPA

2.2.13 Vacuum Units Set Command

This command sets the units the dispenser is using to display Vacuum.

Host Format: E7--uu

uu: The vacuum units. 00 = KPA, 01 = Inches H₂O, 02 = Inches Hg, 03 = mmHg, 04 = TORR.

2.2.14 Dispense Parameter Memory Clear

This command will re-initialize the dispensing parameters memory locations by setting them all to 0.

Host Format: CL--

2.2.15 Deposit Count Clear Command

This command will reset the deposit counter on the dispenser to all zeros.

Host Format: EA--

2.2.16 Reset Auto Increment Command

This command resets the Auto Increment functions. The Ultimus V will set the Memory Address to the Start Address Value, reset the counters, and clear the auto increment alarm. If the Ultimus V is not in counter or timer mode, the dispenser will return an error (A2).

Host Format: SE--

2.2.17 Auto Increment On / Off Command

This command enables or disables the Auto Increment mode. When enabling Auto Increment Mode, the Ultimus V will enable to Count Mode. This command is not necessary to enable Auto Increment Mode. The Auto Increment Mode command can be used instead.

Host Format: AI--i

i: Enable Command. 0=OFF, 1 = ON

2.2.18 Auto Increment Mode Command

This command changes the Auto Increment Mode to either Timer, Counter, or Auto Sequence mode. This command also updates the lower four digits of the trigger value.

Host Format: AC--SsDdddd

s: Mode Command. 1 = Timer Mode, 2 = Counter Mode, 4 = Auto Sequence Mode.

dddd: Trigger Value. 0001–9999

Appendix B — RS-232 Connection Protocol (continued)

2.2.19 Set Start & End Address Command

This command downloads the auto increment start and end addresses.

Host Format: SS--SsssEeee

sss: Start Address 000–399

eee: End Address 000–399

2.2.20 Set Trigger Value Command

This command downloads the 5-digit trigger value into the current memory location.

Host Format: EQ--Ttttt

tttt: Trigger Value. 00001–99999

2.2.21 Set the Real Time Clock Command

This command sets the time on the real time clock on the Ultimus V

Host Format: EB--HhhMmmAMa

hh: Hours. 0–23 for 24 Hour format, 1–12 for 12 Hour Format

mm: Minutes. 0–59

a: Hour format. 0 = AM, 1 = PM, 2 = 24 Hour Format

2.2.22 Set the Real Time Date Command

This command sets the date on the real time clock on the Ultimus V

Host Format: EC--MmmDddYyy

mm: Months. 1–12

dd: Days. 1–31

yy: Years. 00–99

Appendix B — RS-232 Connection Protocol (continued)

2.2.23 Operator Lockout Set Command

This command updates the operator lockout settings. A “1” indicates that a feature is locked out. A “0” indicates that the feature is not locked out.

Host Format: EG--PAppppDTtDPpDVvMmDCcDMdAlaARuALbMMePUfVUgLAhCLjCOkAMn

pppp: 4-digit password. This needs to match the password set on the dispenser. The dispenser will return an error if incorrect.

- t:** Lockout dispense time: “1”=lockout, “0”=enabled (DT)
- p:** Lockout dispense pressure (DP)
- v:** Lockout dispense vacuum (DV)
- m:** Lockout memory cell selection (M)
- c:** Lockout deposit counter selection (DC)
- d:** Lockout dispense mode change (DM)
- a:** Lockout Auto Increment Mode selection (AI)
- u:** Lockout Auto Increment Reset (AR)
- b:** Lockout Alarms Reset (AL)
- e:** Lockout Main Menu selection (MM)
- f:** Lockout Pressure Unit Menu selection (PU)
- g:** Lockout Vacuum Unit Menu selection (VU)
- h:** Lockout Language Menu selection (LA)
- j:** Lockout Set Clock / Date Menu selection (CL)
- k:** Lockout Set Communications Menu selection (CO)
- n:** Lockout Alarm Options Menu selection (AM)

2.2.24 Set Language Command

This command changes the language setting of the Ultimus V.

Host Format: ED--LI: Language Index

- 0** = English
- 1** = French
- 2** = German
- 3** = Spanish
- 4** = Italian
- 5** = Chinese
- 6** = Japanese
- 7** = Korean

Appendix B — RS-232 Connection Protocol (continued)

2.2.25 Alarm Options Set Command

This command sets the options for all the Ultimus V Alarms. A “1” indicates the alarm feature is enabled. A “0” indicates that alarm feature is disabled.

Host Format: EI--INiIOoILIPOpPLbAEeAOa

- i:** Enable Input Alarm (IN)
- o:** Enable Output of Input Alarm (IO)
- l:** Latch the Input Alarm (IL)
- p:** Enable Output of the Pressure Alarm (PO)
- b:** Latch the Pressure Alarm (PL)
- e:** Enable Auto Increment Alarm (AE)
- a:** Enable Output of the Auto Increment Alarm (AO)

2.2.26 Reset Alarms Command

This command clears any latched alarm in the Ultimus V.

Host Format: EK--

2.2.27 Dispense Command

This command initiates a dispense cycle in the Ultimus V. If the unit is in timed mode, the unit will dispense for the duration currently set in dispense time parameter. If the unit is in steady mode, the unit will begin dispensing. Another dispense command is then needed to end the dispense cycle.

Host Format: DI-

2.3 Feedback Commands

For these commands, the host requests a set of data from the dispenser, which the dispenser will return before ending the transmission.

2.3.1 Pressure Time Feedback Command

This command returns the dispense pressure and dispense time of the specified address. This command will update the LCD screen to the specified memory location. “D0” is the letter “D” followed by the digit “0.”

Host Format: UCccc

ccc: The 3-digit memory location from 0–399. The dispenser will automatically limit value to prevent any errors.

Return Format: D0PDppppDTtttt

pppp: The 4-digit pressure setting excluding the decimal point. This is a unitless value. The valid pressure ranges and decimal point are determined by the pressure units currently selected in the dispenser.

tttt: The 4-digit dispense time value excluding the decimal point. The valid range is 0.000 to 9.999. This command truncates the last decimal place of the dispense time. This was done to make this command compatible with the Musashi FX808 protocol.

Appendix B – RS-232 Connection Protocol (continued)

2.3.2 Memory Channel, Dispense Pressure, and Dispense Time Feedback Command

This command returns the Ultimus V's current memory channel, dispense time and dispense pressure to the host. "D0" is the letter "D" followed by the digit "0."

Host Format: UD---

Return Format: D0ChcccPDppppDTtttt

ccc: The 3-digit memory location from 0–399. The dispenser will automatically limit value to prevent any errors.

pppp: The 4-digit pressure setting excluding the decimal point. This is a unitless value. The valid pressure ranges and decimal point are determined by the pressure units currently selected in the dispenser.

tttt: The 4-digit dispense time value excluding the decimal point. The valid range is 0.000 to 9.999. This command truncates the last decimal place of the dispense time. This was done to make this command compatible with the Musashi FX808 protocol.

2.3.3 Pressure Time Vacuum Feedback Command

This command returns the dispense pressure, dispense time and vacuum of the specified address. This command will update the LCD screen to the specified memory location. "D0" is the letter "D" followed by the digit "0."

Host Format: E8ccc

ccc: The 3-digit memory location from 0–399. The dispenser will automatically limit value to prevent any errors.

Return Format: D0PDppppDTttttVCvvvv

pppp: The 4-digit pressure setting excluding the decimal point. This is a unitless value. The valid pressure ranges and decimal point are determined by the pressure units currently selected in the dispenser.

tttt: The 5-digit dispense time value excluding the decimal point. The valid range is 0.0000 to 9.9999 seconds.

vvvv: The 4-digit vacuum setting excluding the decimal point. This is a unitless value. The valid vacuum ranges and decimal point are determined by the vacuum units currently selected in the dispenser.

2.3.4 Memory Location Feedback Command

This command returns the current memory location to which the dispenser is set. "D0" is the letter "D" followed by the digit "0."

Host Format: UA---

Return Format: D0ccc

ccc: The 3-digit memory location from 0–399.

2.3.5 Pressure Units Feedback Command

This command returns the units the dispenser is using to display pressure. "D0" is the letter "D" followed by the digit "0."

Host Format: E4--

Return Format: D0PUuu

uu: The pressure units. 00 = PSI, 01 = BAR, 02 = KPA

Appendix B — RS-232 Connection Protocol (continued)

2.3.6 Vacuum Units Feedback Command

This command returns the units the dispenser is using to display vacuum. “D0” is the letter “D” followed by the digit “0.”

Host Format: E5--

Return Format: D0VUuu

uu: The vacuum units. 00 = KPA, 01 = Inches H₂O, 02 = Inches Hg, 03 = mmHg, 04 = TORR.

2.3.7 Total Status Feedback Command

This command returns the status and values of the Auto Increment mode as well as the dispense mode. This command is the same command as the Musashi 808FX Total Status command, thus Vacuum Interval mode status is included in the command string. The Ultimus V does not support this mode; therefore this data is defaulted to safe values. “D0” is the letter “D” followed by the digit “0.”

Host Format: AU---

Return Format: D0AliMmSssssDdddddddVlqVvvvlttttTMxSAaaaEAeee

i: Auto Increment mode status. 0 = Off, 1 = Enabled

m: Auto Increment mode function. 1 = Timer, 2 = Count, 4=Auto Sequence Mode

ssss: Trigger Value. The upper digit is truncated to make this function compatible with the Musashi command

ddddddd: Current Timer / Counter value

q: Defaulted to 0

vvvv: Defaulted to 0001

tttt: Defaulted to 0001

x: Dispense mode. 0 = Timed, 1 = Steady, 2 = Teach

aaa: Auto Increment Start Address. 000–399

eee: Auto Increment End Address. 000–399

2.3.8 Trigger Value Feedback Command

This command will return the 5-digit trigger value of the current memory location.

Host Format: ER--

Return Format: D0TVtttt

tttt: 5-digit trigger value. Range is 00000–99999.

2.3.9 Deposit Count Feedback Command

This command will return the current 7-digit deposit count that is stored in the dispenser. “D0” is the letter “D” followed by the digit “0.”

Host Format: E9--

Return Format: D0SCcccccc

cccccc: 7-digit deposit counter. Range is 0000000 to 9999999.

Appendix B – RS-232 Connection Protocol (continued)

2.3.10 Real Time Clock Feedback Command

This command returns the time from the real time clock on the Ultimus V.
“D0” is the letter “D” followed by the digit “0.”

Host Format: EE--

Return Format: D0HhhMmmAMa

hh: Hours. 0–23 for 24 Hour Format, 1–12 for 12 Hour Format

mm: Minutes. 0–59

a: Hour format. 0 = AM, 1 = PM, 2 = 24 Hour Format

2.3.11 Real Time Date Feedback Command

This command returns the date from the real time clock on the Ultimus V.
“D0” is the letter “D” followed by the digit “0.”

Host Format: EF--

Return Format: D0MmmDddYyy

mm: Months. 1–12

dd: Days. 1–31

yy: Years. 00–99

2.3.12 Operator Lockout feedback Command

This command returns the operator lockout settings from the Ultimus V.
“D0” is the letter “D” followed by the digit “0.”

Host Format: EH--PApppp

pppp: 4-digit password. This needs to match the password set on the dispenser. The dispenser will return an error if incorrect.

Return Format: D0DTtDPpDVvMmDCcDMdAlaARuALbMMePUfVUgLAhCLjCOKAMn

t: Lockout dispense time: “1”=lockout, “0”=enabled (DT)

p: Lockout dispense pressure (DP)

v: Lockout dispense vacuum (DV)

m: Lockout memory cell selection (M)

c: Lockout deposit counter selection (DC)

d: Lockout dispense mode change (DM)

a: Lockout Auto Increment Mode selection (AI)

u: Lockout Auto Increment Reset (AR)

b: Lockout Alarms Reset (AL)

e: Lockout Main Menu selection (MM)

f: Lockout Pressure Unit Menu selection (PU)

g: Lockout Vacuum Unit Menu selection (VU)

h: Lockout Language Menu selection (LA)

j: Lockout Set Clock / Date Menu selection (CL)

k: Lockout Set Communications Menu selection (CO)

n: Lockout Alarm Options Menu selection (AM)

Appendix B – RS-232 Connection Protocol (continued)

2.3.13 Alarm Options Feedback Command

This command returns the current settings of the alarm options in the Ultimus V. “D0” is the letter “D” followed by the digit “0.”

Host Format: EJ--

Return Format: D0INiOoILIPOpPLbAEeAOa

- i:** Enable Input Alarm (IN)
- o:** Enable Output Of Input Alarm (IO)
- l:** Latch the Input Alarm (IL)
- p:** Enable Output of the Pressure Alarm (PO)
- b:** Latch the Pressure Alarm (PL)
- e:** Enable Auto Increment Alarm (AE)
- a:** Enable Output of the Auto Increment Alarm (AO)

2.3.14 Alarm Status Feedback Command

This command returns the status of each of the alarms in the Ultimus V. “D0” is the letter “D” followed by the digit “0.”

Host Format: EL--

Return Format: D0INiPApAla

- i:** input Alarm Status: 1= Alarm is set, 2= No alarm
- p:** Pressure Alarm Status
- a:** Auto Increment Alarm Status

NORDSON EFD ONE YEAR LIMITED WARRANTY

This Nordson EFD product is warranted for one year from the date of purchase to be free from defects in material and workmanship (but not against damage caused by misuse, abrasion, corrosion, negligence, accident, faulty installation, or by dispensing material incompatible with equipment) when the equipment is installed and operated in accordance with factory recommendations and instructions.

Nordson EFD will repair or replace free of charge any defective part upon authorized return of the part prepaid to our factory during the warranty period. The only exceptions are those parts which normally wear and must be replaced routinely, such as, but not limited to, valve diaphragms, seals, valve heads, needles, and nozzles.

In no event shall any liability or obligation of Nordson EFD arising from this warranty exceed the purchase price of the equipment.

Before operation, the user shall determine the suitability of this product for its intended use, and the user assumes all risk and liability whatsoever in connection therewith. Nordson EFD makes no warranty of merchantability or fitness for a particular purpose. In no event shall Nordson EFD be liable for incidental or consequential damages.

This warranty is valid only when oil-free, clean, dry, filtered air is used, where applicable.

To register your equipment, please go to www.nordsonefd.com/warranty/dispensers/one.



For Nordson EFD sales and service in over 40 countries, contact Nordson EFD or go to www.nordsonefd.com.

Global

800-556-3484; +1-401-431-7000
info@nordsonefd.com

Europe

00800 7001 7001
infoefd.europe@nordsonefd.com

Asia

China: +86 (21) 3866 9006; china@nordsonefd.com
India: +91 80 4021 3600; india@nordsonefd.com
Japan: +81 03 5762 2760; japan@nordsonefd.com
Korea: +82-31-736-8321; korea@nordsonefd.com
SEAsia: +65 6796 9522; sin-mal@nordsonefd.com

The Wave Design is a trademark of Nordson Corporation.
©2019 Nordson Corporation 7014083 v110219