

JANOME SCARA/GANTRY ROBOT
JS/JSR4400N/JSG Series
JANOME DESKTOP ROBOT
JR2000N Series

Operation Manual

Features IV

(Customizing)

Thank you for purchasing a Janome Robot.

- Read this manual thoroughly in order to ensure proper use of this robot. Be sure to read “For Your Safety” before you use the robot. The information will help you protect yourself and others from possible dangers during operation.
- After having read this manual, keep it in a handy place so that you or the operator can refer to it whenever necessary.
- This manual is written according to IEC 62079.

JANOME

FOR YOUR SAFETY

Safety Precautions



The precautions in this manual are provided for the customer to make the best use of this product safely, and to provide preventive measures against injury to the customer or damage to property.

Please follow these instructions

Various symbols are used in this manual. Please read the following explanations of each symbol.











● Symbols Indicating the Degree of Potential Damage or Danger

The following symbols indicate the degree of damage or danger which may be incurred if the safety notes are ignored.

	Warning	The Warning symbol indicates the possibility of death or serious injury.
	Caution	The Caution symbol indicates the possibility of accidental injury or damage to property.

● Symbols Indicating the Type of Danger and Preventive Measures

The following symbols indicate the type of safety measures that should be taken.

	Indicates the safety measures that should be taken.
	Be careful. (General caution)
	Indicates a prohibition.
	Never do this. (General prohibition)
	Do not disassemble, modify or repair.
	Do not touch.
	Indicates a necessity.
	Be sure to follow instructions.
	Be sure to unplug power cord from wall outlet.
	Be sure to check grounding.

FOR YOUR SAFETY

JR2000N Series

Warning



Do not use the unit where flammable or corrosive gas is present.

Leaked gas accumulated around the unit can cause fire or explosion.



Use the robot in a condensation-free environment between 0 and 40 degrees centigrade with a humidity level of 20 to 95 percent.

Failure to do so may result in malfunction.

IP Protection Rating: IP30 (IP40 for CE specification models)



Use the robot in an electric noise-free environment.

Failure to do so may result in malfunction or breakdown.



Use the robot in an indoor environment where it is not exposed to direct sunlight.

Direct sunlight may cause malfunction or breakdown.



Install the robot in a place which can endure its weight and conditions while running.

Placing the unit in an insufficient or unstable surface may cause the unit to fall or overturn, thereby causing damage or injury.

Leave a space of at least 30cm between the back of the robot (the side with a cooling fan) and the wall. Insufficient space can lead to overheating or fire.



Be sure to use within the voltage range indicated on the unit.

Failure to do so may cause electric shock or fire.



If your robot has the I/O-S circuit, be sure to install a safeguard such as an area sensor when installing the robot.

Without a safeguard, going near the robot while it is operating may cause injury.



Plug the power cord into the wall outlet firmly.

Failure to do so can cause the plug to heat up and may result in fire.

FOR YOUR SAFETY

JR2000N Series

Warning



Wipe the power plug with a clean, dry cloth periodically to eliminate dust.
Dust accumulation can undermine the electrical insulation and cause fire.



Ensure that the robot is properly grounded before use. Do not use without grounding.
Insufficient grounding can cause electric shock and/or fire.



Be sure to use within the voltage range indicated on the unit.
Failure to do so may cause fire or unit malfunction.



Keep water and oil away from the robot and power cable.
Contact with water or oil can cause electric shock, fire, or unit malfunction.
IP Protection Rating: IP30 (IP40 for CE specification models)



If tools have been attached (such as the electric screwdriver), make sure they are properly connected.
Failure to do so may result in injury or breakdown.



During prolonged use, be sure to regularly check that the mounting screws are sufficiently tightened.
Loose screws may cause injury or breakdown.



Be sure to check the wiring to the main unit.
Improper wiring may result in malfunction or breakdown.



Be sure to secure the movable parts of the robot before transportation.
Failure to do so may result in injury or breakdown.

FOR YOUR SAFETY

JR2000N Series

Warning



Do not bump or jar the unit while it is being transported or installed.
Doing so can cause breakdown.



Be sure to check that no danger is around the operator before starting the robot.
Careful attention will protect the operator from injury.



Do not attempt to disassemble or modify the unit.
Disassembly or modification may cause electric shock or malfunction.



Be sure to unplug the power cord from the wall outlet when examining or lubricating the machine.
Failure to do so may cause electric shock or injury.



If anything unusual (e.g. a burning smell or an abnormal sound) occurs, stop operation and unplug the cable immediately. Contact the dealer from whom you purchased the robot or the office listed on the last page of this manual.
Continuous use without repair can cause electric shock, fire, or unit breakdown.



Do not leave the unit plugged in (power cord and connectors) when it is not in use for long periods of time. Accumulated dust can cause fire.
Be sure to shut off the power supply before removing the power cord.



Be sure to turn off the robot before inserting and removing all cables.
Failure to do so may result in electric shock, fire, data loss or unit malfunction.



Keep the emergency stop switch within reach of an operator while teaching or running the robot.
Failure to do so is dangerous since it may not be possible to stop the robot immediately and safely.

FOR YOUR SAFETY

JR2000N Series

Warning



Regularly check that the emergency stop switch works properly.

For models with I/O-S circuits, also check that they work properly.

Failure to do so is dangerous since it may not be possible to stop the robot immediately and safely.

FOR YOUR SAFETY

JSR4400N Series

Warning



Do not leave the unit plugged in (power cord and connectors) when it is not in use for long periods of time. Accumulated dust can cause fire.
Be sure to shut off the power supply before removing the power cord.



Keep the emergency stop switch within reach of an operator while teaching or running the robot.

Failure to do so is dangerous since it may not be possible to stop the robot immediately and safely.



Regularly check that the emergency stop switch works properly.

For models with I/O-S circuits, also check that they work properly.

Failure to do so is dangerous since it may not be possible to stop the robot immediately and safely.



During prolonged use, check the mounting screws etc, regularly and ensure that they are firmly tightened.

Loose screws may cause injury or breakdown.



Be sure to use within the voltage range indicated on the unit.

Failure to do so may cause fire or unit malfunction.



Keep water and oil away from the robot and power cable.

Contact with water or oil can cause electric shock, fire, or unit malfunction.

IP Protection Rating: IP20



Wipe the power plug with a clean, dry cloth periodically to eliminate dust.

Dust accumulation can undermine the electrical insulation and cause fire.

FOR YOUR SAFETY

JSR4400N Series INSTALLATION

Warning



Always set up a safety barrier.

Anyone entering the operating range of the robot may be injured.

Set up an emergency stop interlock system that is triggered when the entrance to the safety barrier is opened.

Use the I/O-S connector included in the package. Ensure there is no other way of entering the restricted area.

Furthermore, **put up a “No Entry” or “No Operating” warning sign in a clearly visible place.**

(An example setup is pictured here.)

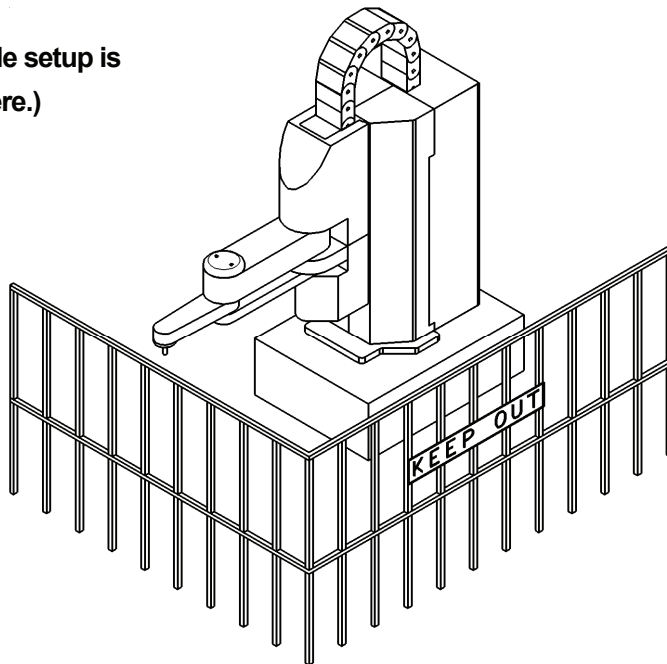

Make sure the safety barrier is strong enough to protect the operator from flying debris caused during robot operation.

Always wear protective gear (helmet, protective gloves, protective glasses, and protective footwear) when going inside the safety barrier.



If the object the robot is holding is in danger of flying off or falling, make sure **safety precautions adequate for the object’s size, weight, temperature and chemical composition have been taken.**

FOR YOUR SAFETY

JSR4400N Series INSTALLATION

Warning



Be sure to check grounding before using the unit.

Improper grounding can cause electric shock, fire, unit malfunction, or breakdown.



Install the robot in a place which can endure its weight and conditions while running.

Placing the unit in an insufficient or unstable surface may cause the unit to fall or overturn, and may cause injury or damage.



There is an air intake vent on the lower back of the robot (18mm above the ground). Do not block this vent, or overheating or fire may result.



Do not use the unit in the presence of flammable or corrosive gas.

Leaked gas accumulated around the unit can cause fire or explosion.



For the health and safety of the operator, place the unit in a well-ventilated area.



Use the robot in a condensation-free environment between 0 and 40 degrees centigrade with a humidity level of 20 to 90 percent.

Failure to do so may result in malfunction.
IP Protection Rating: IP20



Use the robot in an electric noise-free environment.

Failure to do so may result in malfunction or breakdown.



Use the robot in an indoor environment where it is not exposed to direct sunlight.

Direct sunlight may cause malfunction or breakdown.



Be sure to use within the voltage range indicated on the unit.

Failure to do so may cause electric shock or fire.

FOR YOUR SAFETY

JSR4400N Series INSTALLATION

Warning



Do not attempt to disassemble or modify the unit.

Disassembly or modification may cause electric shock or malfunction.



Be sure to secure the movable parts of the robot before transportation.

Failure to do so may result in injury or breakdown.



Do not bump or jar the unit while it is being transported or installed.

Doing so can cause breakdown.



Be sure to confirm that all the air tubes are connected correctly and firmly.



If tools have been attached (such as the electric screwdriver), make sure they are properly connected.

Failure to do so may result in injury or breakdown.



Be sure to check the wiring to the main unit.

Improper wiring may result in malfunction or breakdown.



Keep the emergency stop switch within reach of an operator while teaching or running the robot.

Failure to do so is dangerous since it may not be possible to stop the robot immediately and safely.



Turn off the unit before inserting and removing cables.

Failure to do so may result in electric shock, fire, or unit malfunction.



Be sure to turn off the robot before plugging it in.

FOR YOUR SAFETY

JSR4400N Series INSTALLATION

Warning



Plug the power cord firmly into the wall outlet.

Incomplete insertion into the wall outlet causes the plug to heat up and may result in fire. Be sure to turn off the robot y before connecting the power cable.



Place the operation box on a flat surface more than 80 cm above the floor so that it is easier to operate it.



Use the unit in an environment that is not dusty or damp.

Dust or dampness may lead to breakdown or malfunction.
IP Protection Rating: IP20

FOR YOUR SAFETY

JSR4400N Series DURING OPERATION

Warning



When lubricating or inspecting the unit, unplug the power cord from the robot.

Failure to do so may result in electric shock or injury.

Be sure to shut off the power supply before removing the power cord from the robot.



Put up a **“Do Not Operate”** sign on the start switch when people are entering the safety barrier.



Keep the emergency stop switch within reach of an operator while teaching or running the robot.

Failure to do so is dangerous since it may not be possible to stop the robot immediately and safely.



Make sure the safety barrier is strong enough to protect the operator from flying debris caused during robot operation.

Always wear protective gear (helmet, protective gloves, protective glasses, and protective footwear) when going inside the safety barrier.



Make sure all the air tubes are connected correctly and firmly.



Always be aware of the robot's movement, even in the Teaching mode.

Careful attention will protect the operator from injury.

FOR YOUR SAFETY

JSR4400N Series DURING OPERATION

Warning



When entering the safety barrier, **do not enter the operating range of the robot.**



If you must go inside the safety barrier, make sure you **push the emergency stop switch** and put a **“Do Not Operate” sign** on the start switch.



When activating the robot, check that **no one is inside the safety barrier and that no object will interfere with the robot’s operation.**



Under no circumstances should you go inside the safety barrier or place your hands or head inside the safety barrier while the robot is operating.



If anything unusual (e.g. a burning smell or an abnormal sound) occurs, stop operation and turn off the robot. Contact the dealer from whom you purchased the robot or the office listed on the last page of this manual.
Continuous use without repair can cause electric shock, fire, or breakdown of the unit.



Keep the emergency stop switch within reach of an operator while teaching or running the robot.
Failure to do so is dangerous since it may not be possible to stop the robot immediately and safely.

FOR YOUR SAFETY

JS Series and JSG Series

Warning



When not in use for extended periods of time, unplug the power cord from the power source. Accumulated dust leads to fires.

When unplugging the cord, make sure the power is off.



Change the robot battery periodically (approximately every three years) to prevent unit malfunction or breakdown.



Keep the emergency stop switch within reach of an operator while teaching or running the robot.

Failure to do so is dangerous since the robot may not be able to be stopped immediately and safely.



Regularly check that the I/O-S circuits and emergency stop switch work properly.

Failure to do so is dangerous since the robot may not be able to be stopped immediately and safely.

FOR YOUR SAFETY

JS Series and JSG Series

Warning



During prolonged use, check the mounting screws etc, regularly and ensure that they are firmly tightened.

Loose screws may cause injury or breakdown.



Power the unit only with the rated voltage.

Excessive voltage can cause fire or unit malfunction.



Keep water or oil away from the robot, control box and power cable.

Contact with water or oil can cause electric shock, fire, or unit malfunction.

IP Protection Rating: IP40

FOR YOUR SAFETY

JS Series and JSG Series INSTALLATION

Warning



Always set up a safety barrier.

Anyone entering the operating range of the robot may be injured.

Set up an emergency stop interlock system that is triggered when the entrance to the safety barrier is opened.

Use the I/O-S connector included in the package. Ensure there is no other way of entering the restricted area.

Furthermore, **put up a “No Entry” or “No Operating” warning sign** in a clearly visible place.

(An example setup is
pictured here.)

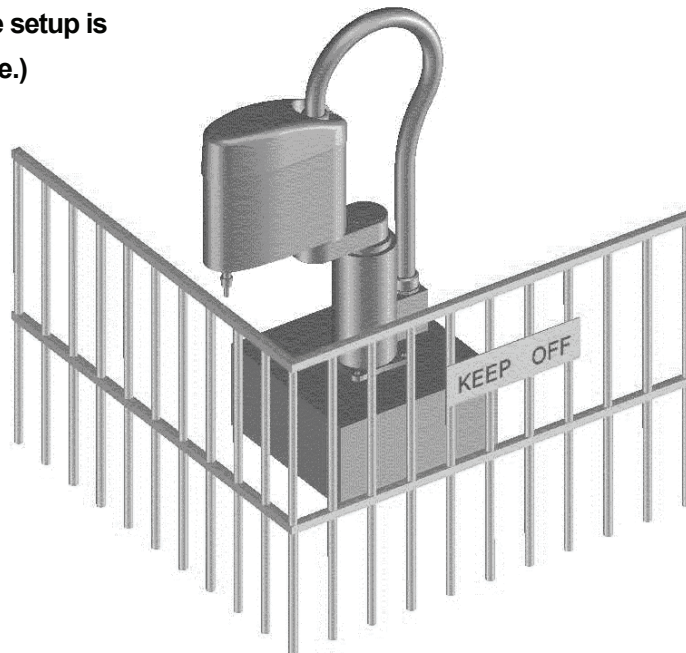

Make sure the safety barrier is strong enough to protect the operator from flying debris caused during robot operation.

Always wear protective gear (helmet, protective gloves, protective glasses, and protective footwear) when going inside the safety barrier.



If the object the robot is holding is in danger of flying off or falling, make sure **safety precautions adequate for the object’s size, weight, temperature and chemical composition have been taken.**

FOR YOUR SAFETY

JS Series and JSG Series INSTALLATION

Warning



Be sure to check grounding before you use the unit.

Improper grounding can cause electric shock, fire, unit malfunction, or breakdown.



Plug the power cord firmly into the wall outlet and check for dust.

Incomplete insertion into the wall outlet causes the plug to heat up and may result in fire.

Be sure to shut off the power supply before connecting the power cable.



Install the robot in a place which can endure its weight and conditions while running.

Placing the unit in an insufficient or unstable surface may cause the unit to fall or overturn, thereby causing damage or injury.

Be sure to leave a space of at least 30cm between the back of the robot (the side with a cooling fan) and the wall. Insufficient space can lead to overheating or fire.



Do not attempt to disassemble or modify the unit.

Disassembly or modification may cause electric shock or malfunction.



Be sure to use within the voltage range indicated on the unit.

Failure to do so may cause electric shock or fire.



Do not use the unit where flammable or corrosive gas is present.

Leaked gas accumulated around the unit can cause fire or explosion.



For the health and safety of the operator, place the unit in a well-ventilated area.



Turn off the unit before inserting and removing cables.

Failure to do so may result in electric shock, fire, or unit malfunction.

FOR YOUR SAFETY

JS Series and JSG Series INSTALLATION

Warning



Be sure to confirm that all the air tubes are connected correctly and firmly.



Use the robot in a condensation-free environment between 0 and 40 degrees centigrade with a humidity level of 20 to 90 percent.
Failure to do so may result in malfunction.
IP Protection Rating: IP40



Use the robot in an electric noise-free environment.
Failure to do so may result in malfunction or breakdown.



Be sure to secure the movable parts of the robot before transportation.
Failure to do so may result in injury or breakdown.



Do not bump or jar the unit while it is being transported or installed.
Doing so can cause breakdown.



Use the robot in an indoor environment where it is not exposed to direct sunlight.
Direct sunlight may cause malfunction or breakdown.



If tools have been attached (such as the electric screwdriver unit), make sure they are properly connected.
Failure to do so may result in injury or breakdown.



Check the wiring to the main unit.
Improper wiring may result in malfunction or breakdown.



Keep the emergency stop switch within reach of an operator while teaching or running the robot.
Failure to do so is dangerous since it may not be possible to stop the robot immediately and safely.

FOR YOUR SAFETY

JS Series and JSG Series INSTALLATION

Warning



Be sure to turn off both the robot and the power source before plugging in the power cable.



Be sure to remove the eyebolt after installing the robot.
If it is not removed, the Arm may bump into it, thereby causing damage or injury.



Place the control box on a flat surface more than 80 cm above the floor so that it is easier to operate it.



Use the unit in an environment that is not dusty or damp.
Dust or dampness may lead to breakdown or malfunction.
IP Protection Rating: IP40



Use the Clean Room type model in an environment of Clean Class 10* or less.

*: Federal Standard 209D (FED-STD209D)

FOR YOUR SAFETY

JS Series and JSG Series

DURING OPERATION

Warning



When lubricating or inspecting the unit, unplug the power cord from the robot.

Failure to do so may result in electric shock or injury.

Be sure to shut off the power supply before removing the power cord from the robot.



Put a **“Do Not Operate” sign** on the start switch when people are entering the safety barrier.



Keep the emergency stop switch within reach of an operator while teaching or running the robot.

Failure to do so is dangerous since it may not be possible to stop the robot immediately and safely.



Make sure the safety barrier is strong enough to protect the operator from flying debris caused during robot operation.

Always wear protective gear (helmet, protective gloves, protective glasses, and protective footwear) when going inside the safety barrier.



Make sure all the air tubes are connected correctly and firmly.



Always be aware of the robot's movement, even in the Teaching mode.

Careful attention will protect the operator from injury.

FOR YOUR SAFETY

JS Series and JSG Series DURING OPERATION

Warning



When entering the safety barrier, **do not enter the operating range of the robot.**



If you must go inside the safety barrier, make sure you **push the emergency stop switch** and **put a “Do Not Operate” sign** on the start switch.



When starting the robot, check that **no one is within the safety barrier and that no object will interfere with the robot’s operation.**



Under no circumstances should you go inside the safety barrier or place your hands or head inside the safety barrier while the robot is operating.



If anything unusual (e.g. a burning smell or an abnormal sound) occurs, stop operation and turn off the robot. Contact the dealer from whom you purchased the robot or the office listed on the last page of this manual.
Continuous use without repair can cause electric shock, fire, or breakdown of the unit.



Keep the emergency stop switch within reach of an operator while teaching or running the robot.

Failure to do so is dangerous since it may not be possible to stop the robot immediately and safely.

PREFACE

The Janome Desktop Robot JR2000N Series and pulse motor driven Janome SCARA Robot JSR4400N Series are a new style of low-cost, high-performance robots. We have succeeded in reducing the price while maintaining functionality. Energy- and space-saving qualities have been made possible through the combined use of stepping motors and specialized micro step driving circuits.

The servomotor driven Janome SCARA Robot JS Series and servomotor driven Gantry Robot JSG Series feature diverse applications, high speed, rigidity and precision, and can accommodate a wide variety of requirements.

There are several manuals pertaining to these robots.

Setup	Explains how to set up the robot. <ul style="list-style-type: none"> ● Be sure to read this manual before you operate the robot. ● This manual is designed for people who receive safety and installation instructions regarding the robot.
Maintenance	Explains maintenance procedures for the robot. <ul style="list-style-type: none"> ● Be sure to read this manual before you operate the robot. ● This manual is designed for people who receive safety and installation instructions regarding the robot.
Basic Instructions	Provides part names, data structures, and the basic knowledge necessary to operate the robot.
Quick Start	Explains the actual operation of the robot with simple running samples.
Teaching Pendant Operation	Explains how to operate the robot via the teaching pendant.
PC Operation	Explains how to operate the robot from a computer (using the JR C-Points software).
Features I	Explains point teaching.
Features II	Explains commands, variables, and functions.
Features III	Explains features such as run mode parameters, sequencer programs, and other functions used during operation.
Features IV	Explains features in the Customizing mode.
External Control I (I/O-SYS)	Explains the I/O-SYS control.
External Control II (COM Communication)	Explains the COM communication control system (COM1 – COM3).
Specifications	Outlines general specifications such as the robot's operating range, weight, etc.

Note: These products are regularly updated, therefore the product specification outlines in this manual may differ from those of the robot in your possession.

These manuals are based on the standard specifications. Menu items may vary depending on the model.

Please be sure to follow the instructions described in these manuals. Proper use of the robot will ensure continued functionality and high performance.



Be sure to turn off the robot and check that the power to the robot is shut off before plugging in the power cord.



BE SURE TO PROPERLY GROUND THE MACHINE WHEN INSTALLING.



Be sure to save data whenever it is added or modified.
Any unsaved data will be lost when the robot is turned off.

CONTENTS

Features IV

FOR YOUR SAFETY	i
PREFACE	xxi
CONTENTS	xxiii
CUSTOMIZING MODE SUMMARY	1
TYPES OF SETTING	6
■ Identifier String	6
■ Multilingual String	6
■ Four-Digit Number (Security Code)	6
■ Selection	6
■ Numeric Value	7
■ Command Line	7
■ Array of Points Type	7
■ IOM	7
ACCOUNT	8
■ Make New Account	8
■ Preset Account (user)	9
■ Login	9
■ Logout	9
■ Account Deletion	9
■ Copy Inhibit	9
■ Copy Inhibit to Other Robots	10
■ Transfer	10
PROTECT MODE	11
POINT TYPE DEFINITION	12
■ Identifier	14
■ Base Type	15
■ Point Type Caption	16

■ Job	17
Job before Moving	17
Job while Moving	17
Point Job	17
Job while CP Moving	17
■ Point Setting Variables Definition	18
SETTING VARIABLES DEFINITION	23
■ Identifier	28
■ Protect Mode	28
■ Variable Type	28
■ Hide Control	29
■ Variable Caption	30
■ Number of Selections	30
■ Selection Item Caption	31
■ Input Unit	31
■ Default Value, Maximum Value, and Minimum Value	31
■ Default Number of Points	32
■ Default Points	32
■ PTP Condition Number	32
GLOBAL VARIABLES AND KEEPING VARIABLES	34
USER FUNCTION DEFINITION	35
ALIAS	36
■ I/O Alias	36
■ COM Alias	38
POINT JOB/ADDITIONAL FUNCTION/SEQUENCER	39
TEACHING MODE CUSTOMIZING	40
■ Caption	40
■ Display Sequence	41
■ Menu Items	43
■ Default	44
Default Program Data	44
Default Run Mode Parameter	44
DATA SAVE	45

CUSTOMIZING MODE SUMMARY

The Customizing mode supports the Teaching mode.

Data created in the Customizing mode is referred to as *customizing data*. Customizing data (with the exception of the Teaching Mode Customizing settings) will be protected with an account.

If you register the command lines used for point job data as a function (this operation is referred to as *user function definition*), you can enter the same command lines just by using a function call command.

If you define the point type (this operation is referred to as *point type definition*) to perform the same jobs at multiple points in a program, you can register the job points just by selecting the point coordinates and the point type.

For example, in the Teaching mode, if you wish to turn on the #genOut1 signal for 0.5 seconds, select a point job data number (e.g. [1]) and register the point job data (e.g. Job01 on the right side of the flow chart below) under the number. To perform this operation at the first point (Point 1), display the point settings screen for Point 1 and select [Point Job Number]. The Point Job Number entry screen will appear. Then set [1] as the [Point Job Number] on the screen. (To display the point job settings screen, press the **[SHIFT]** + **[ESC]** keys.)

If you wish to turn on the #genOut1 signal when the CP drive starts, select a point job data number (e.g. [2]) and register the point job data (e.g. Job02 on the right side of the flow chart below) under the number. To perform this operation at the second point (Point 2), set [2] on the Point Job Number entry screen for Point 2.

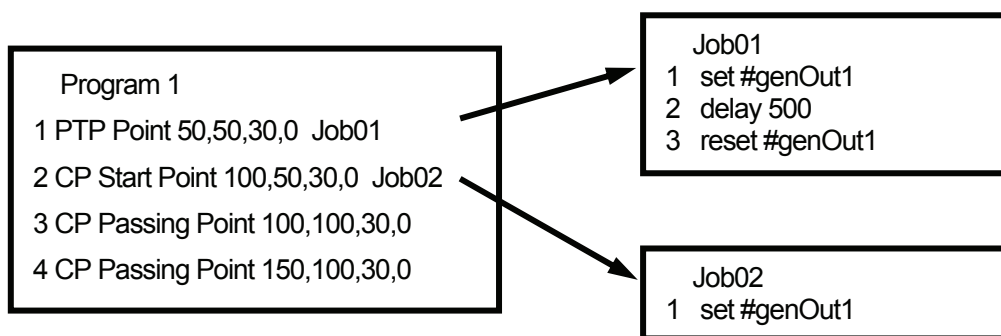

However, assigning too many point job numbers may lead to confusion and complication. It can be even more complicated if the [Job before Moving] settings are also implemented.

In this method, you need to create multiple point job data items if you wish to change the amount of time the signal is turned on (50msec = 0.5sec in this example) at each point.

In the Customizing mode, you can define a new point type that has a pre-defined point job (equivalent to Job01) and its parameters (e.g. OutOnTime: Time the signal is turned on). Point types you define are referred to as *user-defined point types*. You can select the user-defined point types when you register the points.

Using this mode, you can register points just by selecting the user-defined point type (e.g. Point Output, Line Start, etc.) and entering the OutOnTime. You do not need to set up a point job data number for each point.

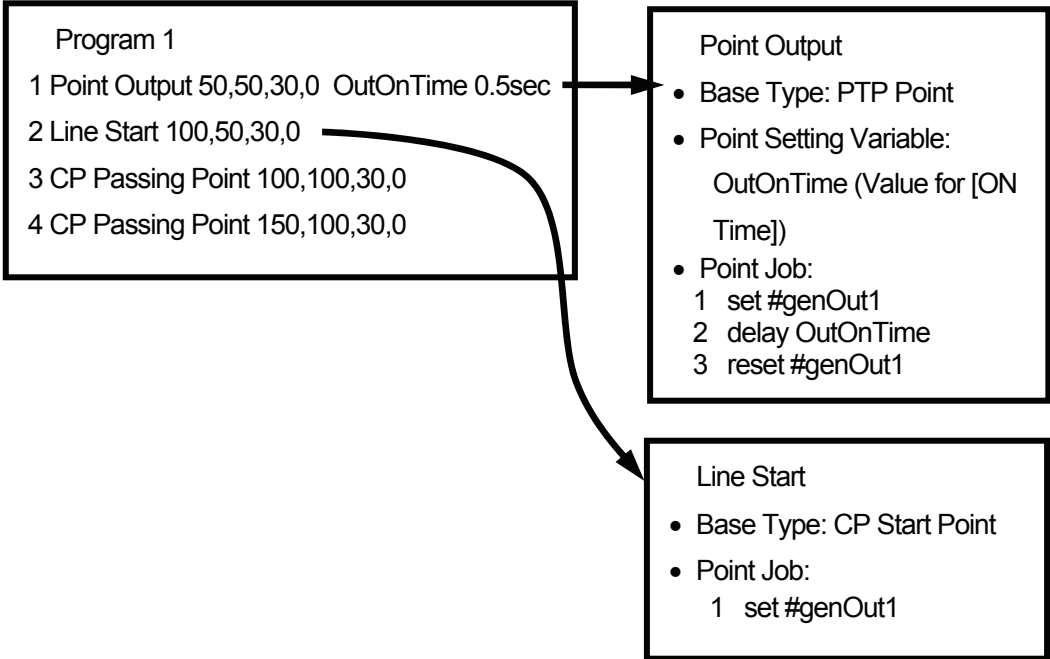

In the above chart, [Point Output] and [Line Start] are the point types defined in the Customizing mode. In the point type definition, you can set the point type name displayed on the point type selection screen in the Teaching Mode (referred to as a *caption*). The [Point Output] and [Line Start] are the captions.

[Base Type] is the point type used for defining a new point type. In this example, [Point Output] is the new point type defined using [PTP Point]. Therefore the robot will run in the same way as in the PTP drive. The robot will start the CP drive from the point at which [Line Start] is set since it has been defined using [CP Start Point].

Parameter values (the value for [ON Time] in this example) are put into [Point Setting Variable].

If you create user-defined point types (such as [Point Output] and [Line Start] as shown on the previous page), you can register points just by selecting the user-defined point types in the Teaching mode. The following is an example of point teaching using the teaching pendant:

When registering a new point in the Teaching mode, the Point Type selection screen shown to the right will appear after entering the point coordinates and pressing the **ENTR** key.

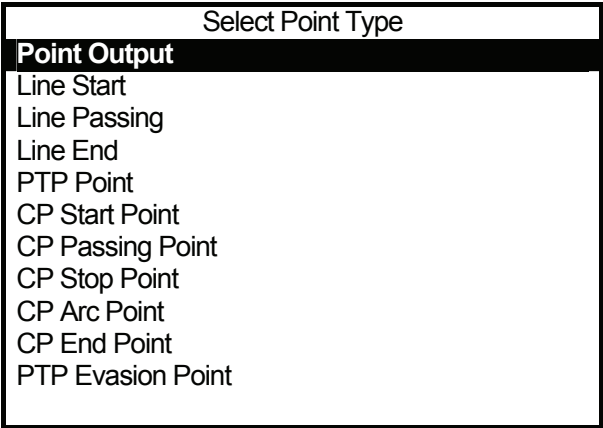

User-defined point types [Point Output], [Line Start], [Line Passing], and [Line End] will also be displayed.

Select [Point Output]. The ON Time entry screen shown to the right will appear. [ON Time] is a parameter for [Point Output].

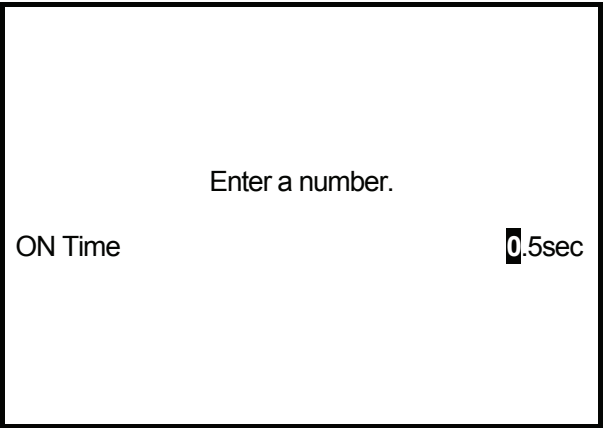

Enter the desired value for the time the signal output is on. [Point Output] to turn the signal on for 0.5 seconds will be set to Point 1.

When the robot starts running and shifts to the coordinates of Point 1, it will perform the point job defined in [Point Output]. In this example, the #genOut1 signal will be turned on for 0.5 seconds.

User-defined point types make point teaching very simple and easy.

Point type definition is the main feature of the Customizing mode.
There are other features that will also make point teaching easier.

In the Customizing mode, you can define [Setting Variables].

The point setting variable (ON Time) is set to each point in the example on the previous page; however, you can set the setting variables to individual programs or all programs. You can also set the setting variables as condition data which can be referred to using the condition number set to the point.

The variables are referred to as [Program Setting Variables], [Common Setting Variables], and [Condition Setting Variables] and can be defined in the Customizing mode.

If these variables have been defined previously, you can change the robot's movement by setting values in point teaching.

The values set in point teaching can be used in point job data using its variable identifier. In the point type definition, create a point job command to change the robot's movement by referring to the set values.

[IO-Alias] specialized in I/O and [COM-Alias] specialized in COM have the same feature as [Common Setting Variables].

Particular names such as *#sysIn1* and *port2* are pre-assigned to I/O and COM. If you use these particular names as command parameters, input and output destinations will be fixed. You need to change the command parameter in order to change the input and output destinations.

By setting the alias, you can change the input and output destinations on the settings screen in point teaching.

In the Customizing mode, you can define global variables, keeping variables (variables that will not be deleted after turning off the robot), and functions.

Using the Customizing mode settings, you can change the order of the point type display (See "Display Sequence" on Page 41), display items in the Menu (See "Caption" on Page 40), and even prohibit the creation of point job data in the Teaching mode (See "Menu Items" on Page 43).

From a data protection standpoint, customizing data is categorized into two types: [Owner] and [Non-owner].

Data created in the point type definition and setting variables definition is classified as [Owner]. You need an account to handle [Owner] data.

Enter a login name and security code to register an account. Before creating or changing data, log into the account. The created or modified data belongs to the login account.

Using the Protect mode, you can limit access (changing or browsing) to [Owner] data.

[Owner] Customizing Data

- Point Type Definition
- Setting Variables Definition
- Global Variables Definition and Keeping Variables Definition
- Alias Definition
- Function Definition
- Point Job Data, Additional Function Data, Sequencer Data

[Non-Owner] Customizing Data

- Caption
- Display Sequence
- Menu Items
- Default Program Data
- Default Run Mode Parameter

Additional features such as the caption and display sequence (Teaching Mode Customizing menu) are handled as [Non-owner] data. [Non-owner] data cannot be protected in the Protect mode.

TYPES OF SETTING

[Enumeration Type], [Numeric Type], and [String Type] are the bases of the Customizing mode settings as well as the Teaching mode settings. Additionally, there are several types of setting items unique to the Customizing mode.

In this chapter, these setting items will be explained depending on the types. The customizing data settings described hereafter will fall into the types explained in this chapter.

■ Identifier String

You can use up to 40 Roman letters, numbers, and underbars in combination as an identifier. Spaces are invalid.

The identifier is the character string used to distinguish a function, variable, and account.

The name set to a program or point job data functions is a reminder of its contents and the same name can therefore be used for more than one program or point job data. On the other hand, the identifier is used to specify a function, variable, and account, so the same identifier cannot therefore be used.

An identifier can only be used once throughout the whole C & T data, even in different types of data (e.g. a function and an alias). If the entered identifier is invalid, check that it has already been used in other accounts. (See “DATA SAVE” on Page 45 for details of the C&T Data)

■ Multilingual String

For character strings that accommodate different languages: If you set the item name (referred to as a *caption* in this manual) as the multilingual string, you can change the name according to the display language.

■ Four-Digit Number (Security Code)

Use 4-digit numbers as account security codes.

■ Selection

Select an item from the multiple selections. The method is the same as in the Teaching mode.

■ Numeric Value

Enter a numeric value. The method is the same as in the Teaching mode.

■ Command Line

There are several types of command lines created in the point type definition and user function definition. They are created and used in the same way as the point job data. Using the teaching pendant, you can edit (insert or delete) a command or a block of commands by pressing the **EDIT** key.

■ Array of Points Type

[Array of Points Type] is one of the types of setting variables. Enter the point arrays to set the [Array of Points Type] default. The method is the same as when entering multiple point data in the program in the Teaching mode. Using the teaching pendant, you can edit (insert or delete) a point or a block of points by pressing the **EDIT** key.

■ IOM

The external I/O, the internal relay, and the keep (magnetic-storage) relay are collectively referred to as *IOM* in this manual.

Set the type and the number (as well as the width if necessary).

ACCOUNT

Item	Type	Description
Login Name	Identifier String	Character strings used to distinguish a function, variable, and account
Security Code	Four Numbers	Four-digit number necessary for login

The customizing data, such as point type definition, variables definition, user function definition, alias, point job data (Nos. 101 – 200), additional function data (Nos. 51 – 100) and sequencer data (Nos. 51 – 100), except the Teaching Mode Customizing settings, belongs to its owner. The owner is the account holder who created the data.

The owner can set or change the protect mode for each item of data to limit the right of use, change, and access from other accounts.

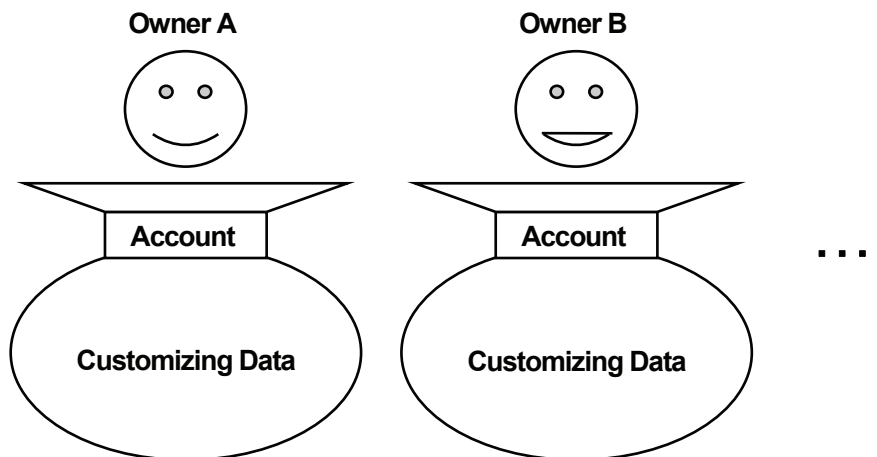

■ Make New Account

An account is necessary in order to log in. Enter the login name and the security code to create an account. You can set up to 50 accounts.

- **Do not forget your security code. Once lost, there is no way to retrieve it.**

■ Preset Account (user)

There is a preset account with the login name [user]. This account does not require a security code, nor is it possible to assign one to it. Therefore, this account is accessible to anyone.

This account can be used if security (limitation of reference or change) is unnecessary or if you have forgotten your security code.

■ Login

After you enter the login name, the four-digit security code entry screen will appear. Once it is authenticated, you are logged in.

■ Logout

To change the account, you must first log out of the system. You cannot log into multiple accounts at one time. You can log out of the system by turning off the robot. However, if you have switched modes while logged in, you have to log out of the system manually.

■ Account Deletion

Accounts can be deleted. If you delete an account, all the customizing data belonging to it will also be deleted. You cannot delete the preset account [user].

- **You can delete other owners' accounts even if you do not know the security codes. Be careful not to delete them accidentally.**

■ Copy Inhibit

This section refers to the [Copy] of data between robots.

You can send data from your robot to a PC using PC software (JR C-Points) and save it in a file.

If you set [Inhibit Copying] to [Inhibition], you cannot send the data in your robot from the PC to another robot that does not have the same account (login name and security code) as your robot. If you set [Inhibit Copying] to [Permission], you can send data from the PC to any robot.

Only the owner can change the copy inhibit ([Inhibit Copying]) settings (either [Permission] or [Inhibition]) under the [Account] menu after login.

- **The copy inhibit settings are invalid for data created by the preset account [user].**

■ Copy Inhibit to Other Robots

Each robot is identified by its ID number.

You can send data from your robot to a PC using the PC software (JR C-Points) and save it in a file. However, if you set [Inhibit Copying to the Other Robot] to [Inhibition], you cannot send data from the PC to other robots that do not have the same ID number as that of your robot.

If [Inhibit Copying to the Other Robot] is set to [Permission], the data of your robot can be transmitted from the PC to any robot.

Only the owner can change the copy inhibit ([Inhibit Copying to the Other Robot]) settings ([Permission] or [Inhibition]) under the [Account] menu after login.

- **The copy inhibit settings are invalid for data created by the preset account [user].**

■ Transfer

If you set [Transfer] to [Permission], you can transfer all the data you own to other accounts by entering the login name of the account to which you want to transfer the data. The security code is not necessary.

Only the owner can change the transfer settings ([Permission] or [Inhibition]) under the [Account] menu after login.

- **Data created by the preset account [user] cannot be transferred.**
- **This setting is currently under development and may be modified to improve quality.**

PROTECT MODE

Data created and set in the Customizing mode is referred to as *customizing data*. The customizing data (with the exception of the Teaching Mode Customizing settings) is protected by the account through the [Protect Mode] function.

Four levels of access limitation are available in the [Protect Mode]. Set the level for each defined data according to the descriptions and table below:

- No Limit: Any access (use, browse, change, and delete) through other accounts is permitted.
- Public: Data can be used and browsed through. However, data cannot be modified or deleted through other accounts.
- Protected: Data can be used through other accounts. However, data cannot be browsed or modified.

You can select data protected in the above three modes. You can also set data as [Base Type] on the point type selection screen in point teaching. [Protected] is the normal protection level.

- Private: No access (use, browse, change, or delete) through other accounts is permitted.

Data protected in this mode will not be displayed on the point type selection screen during point teaching. This mode should be the base type for the owner of the defined data.

Access Limitation against Other Accounts

Protect Mode	No Limit	Public	Protected	Private	(○: no limit, ×: limited)
To use data	○	○	○	×	
To browse data	○	○	×	×	
To change data	○	×	×	×	

For example, if you set the protect mode [Protect] to point job data, you have limited use of the point job data by entering the job number to a point. However, you cannot browse through or change the contents of the data.

Any access (use, browse, or change) from the Teaching mode will be denied regardless of the Protect Mode settings.

- **If you delete an account, all the customizing data belonging to it will also be deleted regardless of the protect mode settings.**

POINT TYPE DEFINITION

[Point Type Definition] is the types of points defined in the Customizing mode. The point type defined in the Customizing mode will be displayed on the point type selection screen in the Teaching mode as well as the pre-defined point types such as [PTP Point].

For example, if you wish to define a point type which stops the SCARA robot until a start command is received, and then shifts the robot Arm to the next point in the PTP drive after receiving the start command, define the point type by setting [Base Type] to [PTP Point] and [Point Job] to [waitStart] on the point type definition screen.

If you set a name for the defined point type ([Wait Start Point] for example) and set it as [Point Type Caption], you can select the point type [Wait Start Point] on the point type selection screen during point teaching.

The following shows an example of how to register the dispensing job performed using the #sysOut16 signal (ON: start dispensing, OFF: stop dispensing):

Create the point job data described below. Then register each point (as a PTP point for example) and set the point job data number as [Point Job] on the point settings screen for each job point.

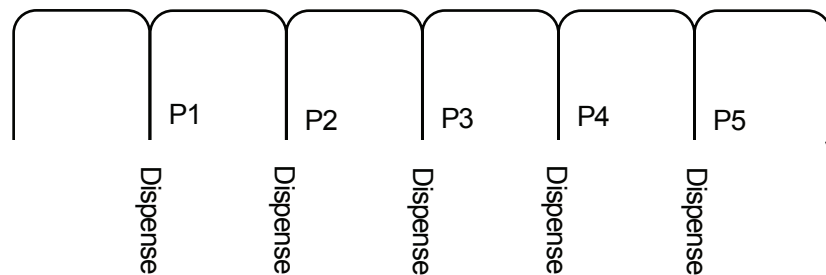

Point Job Data 3

Turn #sysOut16 on. (Start dispensing.)
 Wait for 0.2 seconds.
 Turn #sysOut16 off. (Stop dispensing.)

set #sysOut16 delay 200 reset #sysOut16

If you define a point type by setting [Point Type Caption] as [Dispense Point], [Base Type] to [PTP Point], and the above three commands as the point job, you can register the points to perform the above job just by entering the point coordinates and selecting the point type [Dispense Point] on the point settings screen for each point.

User-defined point types created for performing the desired jobs will make program teaching easier.

If you define a point type in the Customizing mode, the point settings screen will be as shown on the lower right. The robot will perform the same operation as shown on the screen to the left.

Program 1				P1
X+23.2	Y+112.5	Z+25	R+12	
Type				PTP Point
Point Job				3
S.MARK E.MARK J.EXEC P.EXEC				

Without defining the point type

Program 1				P1
X+23.2	Y+112.5	Z+25	R+12	
Type				Dispense Point
S.MARK E.MARK J.EXEC P.EXEC				

After defining the point type

If you set a name for the defined point type ([Dispense Point] in this example) and set it as [Point Type Caption], the point settings screen shown to the right will appear.

You can display the [Dispense Point] line at the top of the list (using [Teaching Mode Display Settings] under [Teaching Mode Customizing] menu) for easy teaching.

Select Item
PTP Point
CP Start Point
CP Passing Point
CP Stop Point
CP Arc Point
CP End Point
PTP Evasion Point
Dispense Point

You can add [Job before Moving] and additional function data to the point type depending on [Base Type] settings. However, if you set the point job while teaching to a point which already has a point job as defined in the point type definition, the defined point type will be ignored along with the [Job before Moving] and additional function data. In the example on the right, Point Job 3 set in the point type definition will be ignored and Point job 5 as set during teaching will be run.

Program 1				P1
X+23.2	Y+112.5	Z+25	R+12	
Type				Dispense Point
Point Job				5
S.MARK E.MARK J.EXEC P.EXEC				

After logging on in the Customizing mode, select the following item:

TP [Point Type Definition]

PC [Customize] → [Point Type Setting]

Item	Type	Description
Identifier	Identifier String	Character string used to distinguish point types and to create a point type code: Specify the identifier when creating a new point type. Once specified, the identifier cannot be changed.
Protect Mode	Selection	Consists of the following four levels to protect data: 1. No Limit, 2. Public, 3. Protected, 4. Private
Base Type	Selection	Select from the pre-defined point types (other than ones to which the protect mode [Private] is set). The standard pre-defined point types (supplied by the system for the standard applications model) are [PTP Point], [PTP Evasion Point], [CP Start Point], [CP Passing Point], [CP Stop Point], [CP Arc Point], and [CP End Point]. The pre-defined point types are used to specify the shifting methods of the robot Axis/Arm to the next point and no point job is assigned to them. One of the pre-defined point types will be assigned to each point type. A user-defined point type is created by adding point job data, such as [Point Job] or [Job before Moving], and additional function data to the pre-defined point type. Any of the user-defined point types and the other pre-defined point types specific to each application can be used as the [Base Type], except the standard pre-defined point types. These point types are used to specify the shifting methods of the robot Axis/Arm to the next point. Point jobs are also assigned to them.
Point Type Caption	Multilingual String	Character string displayed as an item name on the point type selection screen in the Teaching mode
Job before Moving	Command Line	Job to be performed before shifting to a point to which [Job before Moving] is set
Job while Moving	Command Line	Job to be repeated while shifting to a point to which [Job while Moving] is set
Point Job	Command Line	Job to be performed after reaching a point to which [Point Job] is set
Job while CP Moving	Command Line	Job to be repeated after starting the CP drive from a point to which [Job while CP Moving] is set
Point Setting Variables Definition	Sub Menu	Definition of up to 5 variables to be assigned to each point

■ Identifier

The point type definition identifier cannot be referred to in formulas. They can only be used to create the point type code. Simple identifiers are preferable because it is necessary to specify the identifier when editing the point type definition.

■ Base Type

A new point type is defined using another point type as a reference. The reference point type is referred to as a *base type*.

There are two types of base type. As outlined below, one is the standard pre-defined point type (supplied with the system for the standard applications model) and the other is the non-standard point type (specific to each application).

Standard Pre-Defined Point Types

The standard pre-defined point types (supplied by the system for the standard applications model) are [PTP Point], [PTP Evasion Point], [CP Start Point], [CP Passing Point], [CP Stop Point], [CP Arc Point], and [CP End Point].

The pre-defined point types specify the shifting methods of the robot Axis/Arm to the next point.

If you set [PTP Point] as the [Base Type] for a job point, the robot Arm/Axis will move at the point in the same way as it does at a PTP point.

Create a user-defined point type by adding jobs and additional function data to the standard pre-defined point type.

Non-Standard Pre-Defined Point Types

No jobs are assigned to the standard pre-defined point types.

On the other hand, non-standard pre-defined point types for each application (e.g. [Screw Tightening]) include point jobs and setting variables. If you use a non-standard pre-defined point type as a [Base Type], all the items (except the caption) included in the non-standard pre-defined point type, such as the point job and setting variable, will be copied into the [Base Type]. If you do not set a new caption, the newly defined base type will have no caption.

If you add [Job before Moving], [Job while Moving], [Point Job], or [Job while CP Moving] to the base type, the job originally set to the point will be ignored and the newly added job will be performed instead. If you wish to perform both jobs, execute the *callBase* command in a newly added job. The originally set job will be called and performed.

You can add up to 5 setting variables.

■ Point Type Caption

Captions are used instead of identifiers during point teaching (onscreen in the Teaching mode).

The captions set under [Point Type Caption] setting will be displayed on the point type selection screen.

In the example below, [Point Output], [Line Start], [Line Passing], and [Line End] are the captions set to the user-defined point types.

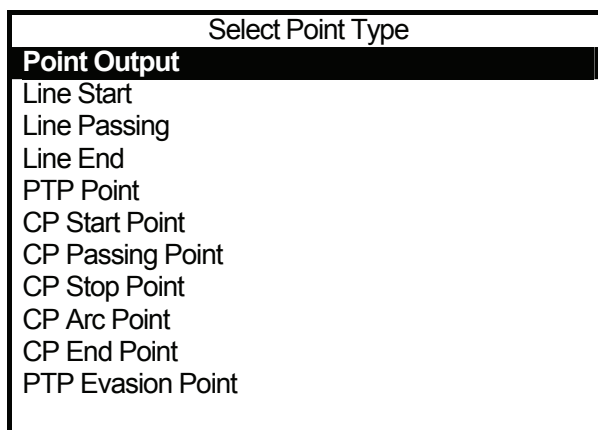

**Example of the Point Type Selection Screen
(Teaching Mode)**

Identifiers can be confusing to work with onscreen, because they are made up of un-spaced Roman characters and numbers. Captions are much easier to work with.

Captions can be set in multiple languages (English, Japanese, German, Italian, Spanish, French, Korean, and Chinese). Set the captions in the desired language for simple point teaching.

If you wish to display the [Line Start] line at the top of the list, you can change the order in which lines are displayed using [Teaching Mode Display Settings] under [Teaching Mode Customizing] menu.

■ Job

You can add four jobs [Job before Moving], [Job while Moving], [Point Job], and [Job while CP Moving] to the user-defined point type.

For details of the point types to which the jobs can be set and when the jobs are performed, see “POINT JOB” on Page 24 of the *Features I* operation manual.

Job before Moving

The [Job before Moving] is performed before the robot Arm/Axis shifts to the set point in the PTP drive. Using this job, you can output a signal, or check for the necessary input signal before the Arm/Axis reaches the set point. You can also perform preparatory tasks such as the lifting of a screw for a screw tightening operation or cleaning for a soldering operation. The *callPoints* command is useful to shift the Arm/Axis for preparation work. (See “Calling Points: callPoints” on Page 69 of the *Features II* operation manual)

Job while Moving

The [Job while Moving] is a repetitive task which is performed while the robot Arm/Axis is shifting to the set point in the PTP drive.

[Job While Moving] allows you to check for the device error signal while the Arm/Axis is shifting, or output a signal according to the coordinate values or the remaining time before reaching the set point.

Any commands to shift the robot Arm/Axis (e.g. *downZ*) are invalid in the [Job while Moving]. If you do not wish to repeat the [Job while Moving], create a variable (e.g. TIGHTENING: You can also use a built-in variable) and set the point job command which resets (e.g. assigns 0 to) the variable to the [Job while Moving] point. Then set the point job command which performs the point job and sets (for example, assigns 1 to) the variable, on the condition that the variable has been reset, to the [Job while Moving] point.

Point Job

The [Point Job] is performed after reaching the set point.

Job while CP Moving

The [Job while CP Moving] is valid only if [CP Start Point] or [CP Stop Point] is used as the base type.

It is performed repeatedly while the robot Arm/Axis is shifting from the set point to the CP passing point or the CP end point in the CP drive.

Using this job, you can check for the device error signal while the Arm/Axis is shifting.

■ Point Setting Variables Definition

The point setting variable has a value at each point. Set the value in teaching and use it as a parameter during operation.

Up to 5 point setting variables can be set to one point.

Item	Type	Description
Identifier	Identifier String	Character string used in the point job data formula: Specify the identifier when creating a new point type. The specified identifier cannot be changed.
Variable Type	Selection	Select the type of variable from the following: 1. Enumeration Type 2. Numeric Type
Variable Caption	Multilingual String	Character string displayed as an item name on the point settings screen in the Teaching mode
TP Input Method	Selection	Method to input values to the point setting variables when registering a new point (selecting a new point type) using the teaching pendant: Select from the following: 1. Default If [Default] is selected, the default values will be input when creating a new point. You do not need to enter each value. This function is useful if you select [Enumeration Type] as [Variable Type] and the desired values are fixed. 2. Input If [Input] is selected, the entry screen or selection screen for each item will appear when creating a new point. Enter each value.

Setting Items of Enumeration Type Point Setting Variable

Item	Type	Description
Number of Selections	Numeric	Number of selections
Selection Item Caption	Multilingual String	Caption that indicates each selection: Displayed on the selection screen during point teaching.

Setting Items of Numeric Type Point Setting Variable

Item	Type	Description
Input Unit	Selection	Select from the following unit to indicate the type of the entered value: [No Unit], [sec] (time), [mm] (length), [deg] (degree), [mm/s] (speed), [%] (percentage), [deg/s] (angular speed), [mm/s ²] (acceleration), [rpm] (revolutions per minute), [°C] (degree centigrade), [Kg] (weight), [msec] (millisecond), and [min] (minute)
Decimal Figure	Selection	Input limitation of number of decimals: Select between [1], [0.1], [0.01], [0.001], [0.0001], [10], [100], and [1000].
Default Value	Numeric	Initial variable value
Maximum Value	Numeric	Maximum setting value: You cannot enter a value larger than the maximum value.
Minimum Value	Numeric	Minimum setting value: You cannot enter a value smaller than the minimum value.

Identifier

The point setting variable identifier is referred to in the point job command formulas.

The following example shows the identifier [OutOnTime] (ON Time), which is referred to in the second line of the point job data.

```
1 set #genOut1
2 delay OutOnTime*1000
3 reset #genOut1
```

Variable Type

Select the type of variable from the following:

- Enumeration Type
- Numeric Type

The selected variable type will affect the display and the operation in point teaching in the Teaching mode.

If [Enumeration Type] is selected, the variables are handled as numerical values (0, 1 ...) when referred to in the point job command formulas.

Variable Caption

The caption will be displayed instead of the identifier on the entry screen and the point settings screen in point teaching.

The following example shows the caption [ON Time] displayed on the entry screen and the point setting screen.

	Program 1	P1
	X+23.2 Y+312.5 Z+25 R+12	
ON Time	Type	Point Output
	ON Time	0.5sec
Enter a number.		
0.5sec		
	S.MARK E.MARK	J.EXEC P.EXEC

TP Input Method

Select the method for inputting values to the point setting variables when registering a new point (selecting a new point type) using the teaching pendant. You can select from the following two methods:

Method 1: Default

If [Default] is selected, the default values will be input when creating a new point. You do not need to enter each value. This function is useful if you select [Enumeration Type] as [Variable Type] and the desired values are fixed.

Method 2: Input

If [Input] is selected, the entry screen or the selection screen for each value will appear when creating a new point. Enter or select each value.

The diagrams to the right show the point teaching process using Methods 1 and 2.

To change the variable value when [Default] is selected, select the variable line on the point settings screen.

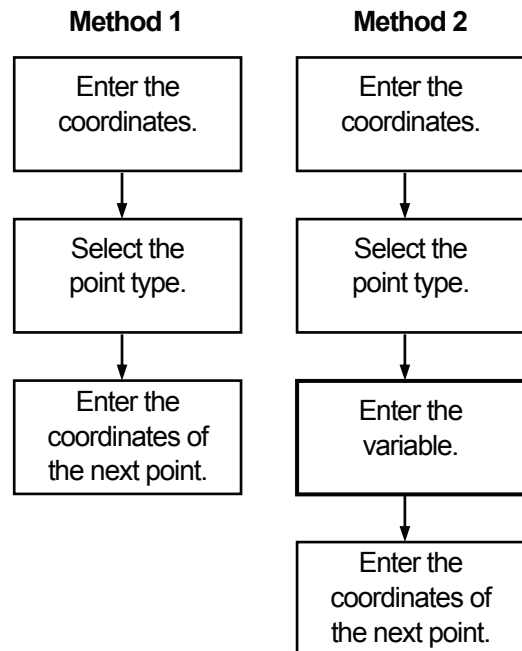

The following two items (Number of Selections and Selection Item Caption) are the settings for the enumeration type point setting variables:

Number of Selections

If [Enumeration Type] is selected, set the variable value according to [Number of Selections] on the selection screen in the Teaching mode. The following selection screen shows five selections:

ESC Signal
No ESC
Manual ESC1
Auto ESC1
Manual ESC2
Auto ESC2

Values 0, 1, 2, 3, and 4 correspond to the five selections.

In this example, the variable value will be [2] if [Auto SEC1] is set.

Selection Item Caption

[Selection Item Caption] is displayed as an item name on the selection screen in point teaching.

In the example on the previous page, the character strings [No ESC], [Manual ESC1], [Auto ESC1], [Manual ESC2], and [Auto ESC2] are the captions.

The following five items (Input Unit, Decimal Figures, Default Value, Maximum Value, and Minimum Value) are the settings for the numeric type point setting variables:

Input Unit

[Input Unit] is used to indicate the type of value entered. Select from the following:

[No Unit], [sec] (time), [mm] (length), [deg] (degree), [mm/s] (speed), [%] (percentage), [deg/s] (angular speed), [mm/s²] (acceleration), [rpm] (revolutions per minute), [°C] (degree centigrade), [Kg] (weight), [msec] (millisecond), and [min] (minute)

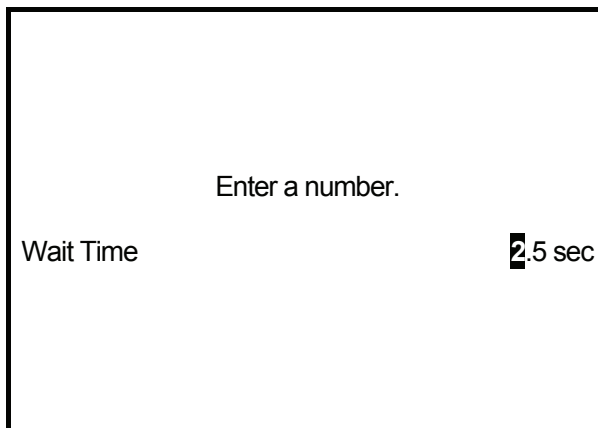

The unit is used to indicate the type of the entered value and does not affect (change) the actual value.

For example, if you set the unit to [sec] to display the [Wait Time] (*nWaitTime*) and use the *delay* command to wait for 2.5 seconds, you need to multiply the *nWaitTime* by 1000 (see below) because the *delay* command requires a millisecond time parameter:

```
delay nWaitTime*1000
```

Decimal Figures

Select the input limitation (number of decimals) from [1], [0.1], [0.01], [0.001], [0.0001], [10], [100], and [1000].

This setting affects the value input in the Teaching mode. For example, if [0.1] is selected, you cannot enter a value smaller than the second decimal.

This setting also affects the minimum and maximum setting values as follows because the point setting variables have fixed-point values due to the integrated settings of the robot:

[1]:	-32768 – 32767
[0.1]:	-3276.8 – 3276.7
[0.01]:	-327.68 – 327.67
[10]:	-327680 – 327670
[100]:	-3276800 – 3276700

However, this setting is basically designed to limit the decimal figures to be entered and does not affect (change) the actual values in the formulas.

For example, if you set [Wait Time] (*nWaitTime*) to [2.1sec] and create the following point job using the *delay* command to wait for 2.1 seconds, the robot will wait for 2.1 seconds whether [Decimal Figure] is set to [0.1] or [0.001]:

```
delay nWaitTime*1000
```

Default Value

Initial values of the numeric type point setting variables

Maximum Value

Maximum setting value: You cannot enter a value larger than the maximum value.

Minimum Value

Minimum setting value: You cannot enter a value smaller than the minimum value.

SETTING VARIABLES DEFINITION

There are three setting variables: the common setting variable, the program setting variable, and the condition setting variable. They are defined in the Customizing mode and their values are set in the Teaching mode.

These three setting variables are handled differently in the Teaching mode. However, they are handled in the same way in the Customizing mode.

Common Setting Variable

The Common Setting Variables are common to all programs and points.

Press the **MENU** key in the Teaching mode and select [Common Data Settings] (See Page 25) from the Teaching Mode Menu to set the necessary values.

For example, if you wish to connect two devices A and B to the robot alternately, the commands controlling them (e.g. point job data) must be changed according to the device to be used. In this situation, if you define the common setting variable [DEVICE] as described below, you can select the desired device using the point job data below.

Common setting variable: DEVICE

Enumeration type

Number of selections: 2 (A and B)

Select either device A or B in the Teaching mode. The value 1 or 0 will be set to the common setting variable [DEVICE].

```
if
  Id DEVICE == 0
then
  ( Process for Device A )
else
  ( Process for Device B )
endif
```

Point Job Data

Program Setting Variable

Program setting variables are used for individual programs.

To set the necessary values, press the **[MENU]** key in the Teaching mode to display the Teaching Mode Menu and then select [Program Data Settings] and [Data for Use] (See Page 25) in order.

For example, if you wish to tighten screw A to workpiece A and screw B to workpiece B using the robot with the electric screwdriver mounted, you need to create point job data to lower the screwdriver. Additionally, if the screws have different thread lengths, you need to create different point job data for each screw.

In this case, if you register programs for each workpiece and define the program setting variables to specify the thread lengths, you can use the same point job data at each point.

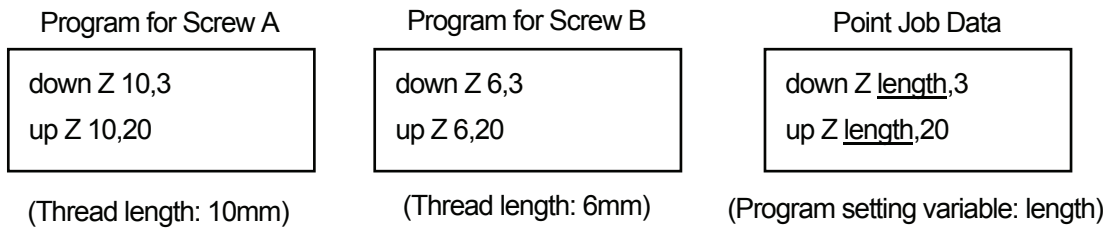

Condition Setting Variable

The condition setting variables are a set of multiple variables which can be set from No. 1 up to No. 500 in the Teaching mode. Set the number to the point to refer to the variable.

Press the **[MENU]** key in the Teaching mode and select [Condition Data Settings] (see Page 25) from the Teaching Mode Menu to set the necessary values.

For example, if you wish to perform the following program using the robot with the dispenser mounted, define the condition setting variables as described on the next page.

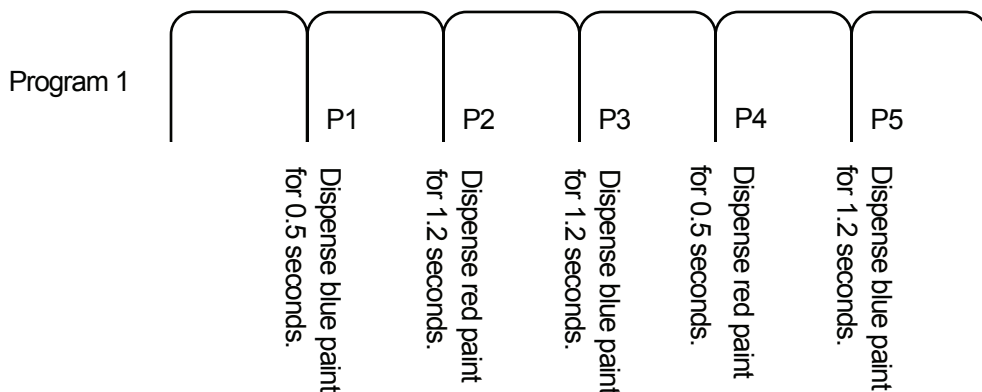

Condition setting variable: COLOR

Enumeration type, Number of selections: 2 (Blue and Red)

Condition setting variable: TIME

Numeric type

After defining the above condition setting variables [COLOR] and [TIME], set the following values in the Teaching mode:

Condition Number	Setting
1	COLOR = BLUE, TIME = 0.5
2	COLOR = BLUE, TIME = 1.2
3	COLOR = RED, TIME = 0.5
4	COLOR = RED, TIME = 1.2

Set condition data No. 1 to P1, condition data No. 4 to P2, condition data No. 2 to both P3 and P5, and condition data No. 3 to P4.

Register the point job shown to the right and set the number (7 in this example) as [Point Job] for P1 – P5.

The dispensing operation will be performed while the #genOut9 signal is on.

The *dataOut 101,#genOut1,8* is a command to change the color to blue. The *dataOut 201,#genOut1,8* is a command to change the color to red.

Program teaching will be easier if you create a user-defined point type by setting [PTP Point] as [Base Type] and the point job data commands to the right as the point job.

*: The captions [Common Data Settings], [Data for Use], and [Condition Data Settings] can be changed under [Teaching Mode Display Settings] in the Teaching Mode Customizing menu. For example, you can change the caption [Condition Data Settings] to [Dispensing Condition] to identify the point job.

For screw tightening applications and soldering applications, the condition data settings caption is preset ([Screw Tightening Condition] and [Soldering Condition]) and cannot be changed.

Point Job Data No. 7
(Underlined part: variable)

```
if
  Id COLOR == 0
then
  dataOut 101,#genOut1,8
else
  if
    Id COLOR == 1
  then
    dataOut 201,#genOut1,8
  else
    waitStartBZ
  endif
endif
set #genOut9
delay TIME*1000
reset #genOut9
```

Select the following items when logged into the Customizing mode:

- TP** [Variable Definition]
 - [Common Setting Variables Definition]
 - [Condition Setting Variables Definition]
 - [Program Setting Variables Definition]

- PC** [Customize] → [Common Setting Variables]
- [Customize] → [Condition Setting Variables]
- [Customize] → [Program Setting Variables]

Item	Type	Description
Identifier	Identifier String	Character string used in the point job data formula: Specify the identifier when creating a new point type. The specified identifier cannot be changed.
Protect Mode	Selection	Consists of the following four levels to protect data: 1. No Limit, 2. Public, 3. Protected, 4. Private
Variable Type	Selection	Select the type of variable from the following: 1. Enumeration Type 2. Numeric Type 3. Array of Points Type
Hide Control	Selection	1. Invalid 2. Valid If [Valid] is selected, you need to set control variables (identifier strings) and display/hide settings. (See Page 29)
Variable Caption	Multilingual String	Character string displayed as an item name on the point settings screen in the Teaching mode

Setting Items of Enumeration Type Setting Variable

Item	Type	Description
Number of Selections	Numeric	Number of selections
Selection Item Caption	Multilingual String	Caption that indicates each selection: Displayed on the selection screen during point teaching in the Teaching mode.

Setting Items of Numeric Type Setting Variable

Item	Type	Description
Input Unit	Selection	Select from the following units to indicate the type of value entered: [No Unit], [sec] (time), [mm] (length), [deg] (degree), [mm/s] (speed), [%] (percentage), [deg/s] (angular speed), [mm/s ²] (acceleration), [rpm] (revolutions per minute), and [°C] (degrees centigrade)
Default Value	Numeric	Initial variable value
Maximum Value	Numeric	Maximum setting value: You cannot enter a value larger than the maximum value.
Minimum Value	Numeric	Minimum setting value: You cannot enter a value smaller than the minimum value.

Setting Items of Array of Points Type Setting Variable

Item	Type	Description
Default Number of Points	Numeric	Initial number of points
Default Points	Array of Points	Initial array of points

Setting Items of PTP Condition Type Setting Variable

Item	Type	Description
PTP Condition Number	Numeric	Same as the PTP condition number defined in the Customizing mode

■ Identifier

Identifiers are used to refer to or assign values in the point job data formulas.

■ Protect Mode

[Protected] is the normal protection level.

If [No Limit], [Public], or [Protected] is selected, the variable caption (e.g. [Common Setting Variables]) will be displayed on the selection screen (e.g. [Common Data Settings]). (Press the **MENU** key to display the selection screen in the Teaching mode.)

Note that other accounts cannot refer to, change, or delete the variable definitions if [Protected] is selected.

If [Private] is selected, the variable caption (e.g. [Common Setting Variables]) will not be displayed on the selection screen (e.g. [Common Data Settings]). (Press the **MENU** key to display the selection screen in the Teaching mode.) It will be displayed only when the account that defined the variable is logged on. Accordingly, other accounts cannot set the variable values in that account. Select [Private] if you wish to protect the data from other accounts and the data is subject to change.

■ Variable Type

Select from the following variables: [Enumeration Type], [Numeric Type], and [Array of Points Type].

You can select [PTP Condition Type] only when [Common Setting Variables] has been selected.

If [Enumeration Type] is selected, the selections will be displayed on the selection screen or settings screen when entering values in the Teaching mode. Select or set the values on the screen. Values (0, 1, 2...) will be assigned to the variables. The input method is unique; however, the variables set under the [Enumeration Type] setting will be handled as numeric type variables if they are referred to from the point job data command.

If [Numeric Type] is selected, the entry screen will appear when entering values in the Teaching mode. Enter the values on the screen. The variables set under the [Numeric Type] setting will be handled as numeric type variables if they are referred to from the point job data command.

[Array of Points Type] is unique to the setting variables. If [Array of Points Type] is selected, you can set a series of points when entering values in the Teaching mode. Using the variable identifiers as a *callPoints* command parameter, you can call the set series of points from the point job data and perform the jobs.

[PTP Condition Type] is unique to the common setting variables. You can edit the contents of the same PTP condition number as that defined in the Customizing mode.

The difference between the two is the menu hierarchy they belong to, and whether the caption is displayed or not. (The caption defined for the PTP condition will be displayed on the [Common Data Settings] screen in the Teaching mode.)

■ Hide Control

You can set the display/hide settings in the Teaching mode using the [Enumeration Type] variable values. Specify the enumeration type variable (identifier) to hide or display the caption. Note that you cannot use more than one enumeration type variable. Also, you cannot correlate the common setting variable with the condition setting variable.

For example, if you wish to create customizing data for two devices (Type A and Type B) which require different parameters (Type A: [rpm] and [sec], Type B: [rpm]), you need to define the following three setting variables:

Identifier	Caption	Variable Type	Note
deviceType	Device Type	Selection	Type A and Type B
rotateSpeed	Rotate Speed	Numeric	
workingTime	Work Time	Numeric	

If you do not set [Hide Control], the invalid selections ([Work Time] for Type B in this example) will be displayed on the settings screen in the Teaching mode.

Common Data Settings

Device Type	Type B
Rotate Speed	
Work Time	

When defining *workingTime* (work time), set [Hide Control] to [Valid] and *deviceType* as a control variable, and then set *workingTime* to [Display] for s1 (Selection 1: Type A in this example) and to [Hide] for s2 (Selection 2: Type B in this example).

Common Data Settings

Device Type	Type A
Rotate Speed	
Work Time	

After setting these, [Work Time] will be displayed on the settings screen in the Teaching mode when [Type A] is selected and will not be displayed on the settings screen in the Teaching mode when [Type B] is selected.

Common Data Settings

Device Type	Type B
Rotate Speed	

■ Variable Caption

A caption will be displayed instead of the identifier on the entry screen and the settings screen in the Teaching mode.

The following examples show the captions [Device Type], [Rotate Speed], and [Work Time] displayed on the settings screen and the entry screen.

Common Data Settings	
Device Type	Type A
Rotate Speed	
Work Time	

Enter a number.	
Rotate Speed	<input type="text" value="1200rpm"/>

The following two items are the settings for the enumeration type setting variables:

■ Number of Selections

If [Enumeration Type] is selected, set the variable value according to [Number of Selections] on the selection screen in the Teaching mode.

The following selection screen shows three selections:

Device Type
Type A
Type B
Type C

Values 0, 1, and 2 correspond to the three selections.

In this example, the variable value will be [1] if [Type B] is set.

■ Selection Item Caption

If [Enumeration Type] is selected, set the [Selection Item Caption] which will be displayed as an item name on the selection screen during point teaching.

In the example on the previous page, the character strings [Type A], [Type B], and [Type C] are the captions.

The following four items (Input Unit, Default Value, Maximum Value, and Minimum Value) are the settings for the numeric type setting variables:

■ Input Unit

[Input Unit] is used to indicate the type of value entered. Select from the following:

[No Unit], [sec] (time), [mm] (length), [deg] (degree), [mm/s] (speed), [%] (percentage), [deg/s] (angular speed), [mm/s²] (acceleration), [rpm] (revolutions per minute), [°C] (degrees centigrade), [Kg] (weight), [msec] (millisecond), and [min] (minute)

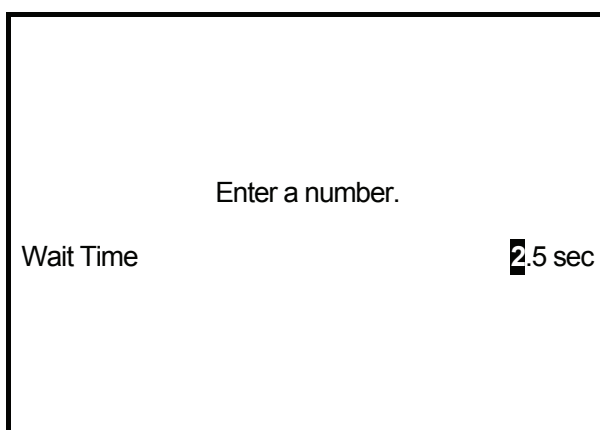

A rectangular input field with a black border. Inside the field, the text "Enter a number." is centered at the top. Below it, on the left side, is the label "Wait Time". On the right side, the value "2.5 sec" is displayed, with the "2" and "." being black and the "5" and "sec" being grey.

The unit is used to indicate the entered value type and does not affect or change the actual value.

For example, if you set the unit to [sec] to display the [Wait Time] (*nWaitTime*) and use the *delay* command to wait for 2.5 seconds, you need to multiply the *nWaitTime* by 1000 as follows because the *delay* command requires a millisecond time parameter:

```
delay nWaitTime*1000
```

■ Default Value, Maximum Value, and Minimum Value

- Default Value: Initial values of the numeric type point setting variables
- Maximum Value: You cannot enter a value larger than the maximum setting value.
- Minimum Value: You cannot enter a value smaller than the minimum setting value.

The following two items (Default Number of Points and Default Points) are the settings for the array of points type setting variables:

■ Default Number of Points

The [Default Number of Points] cannot be entered using the teaching pendant and is not displayed on a PC. Specify the number of points by specifying the block of points instead of entering the value. For example, if you define the variable of the block of three points, the default number of points will be [3].

■ Default Points

If [Array of Points Type] is selected, you can set a block of points when entering values in the Teaching mode. You can run the set block of points using the variable identifiers as a *callPoints* command parameter using the point job data command.

The coordinates of the point blocks and the point job data number defined in the Customizing mode will be the default values in the Teaching mode.

Item	Type	Description
Default Number of Points	Numeric	Initial number of points
Default Points	Array of Points	Initial array of points

The [PTP Condition Type] is unique to the common setting variables.

■ PTP Condition Number

If [PTP Condition Type] is selected, set [PTP Condition Number].

The PTP condition type common setting variable is used in combination with the point type.

For example, if you wish to set a special PTP condition to reduce the shifting speed of the robot's Arm from the screw feeder to the screw tightening point (while the screwdriver is holding a screw), set the additional function data [PTP Condition] to the point type [Point of Feeding].

In this case, if you set the [PTP Condition Number] which is set under this setting to [Point of Feeding] and define the PTP condition type common setting variable, you can enter the contents of the PTP condition which is set to [Point of Feeding] as the common setting variable in the Teaching mode. Even if the PTP condition is included in the Customizing data (PTP Condition Numbers 51 – 100), you can enter the condition number without logging in.

Define the additional function data [PTP Condition Number] as the common setting variable in the Customizing mode and set the common setting variable as the contents of the defined PTP condition number in the Teaching mode. (You cannot change the number in the Teaching mode.)

By doing this, you can edit the contents of the same PTP condition number as that defined in the Customizing mode.

The difference between the two is the menu hierarchy they belong to and whether the caption is displayed or not. (The caption defined for the PTP condition will be displayed on the [Common Data Settings] screen in the Teaching mode.)

Item	Type	Description
PTP Condition Number	Numeric	Same as the PTP condition number defined in the Customizing mode

GLOBAL VARIABLES AND KEEPING VARIABLES

Variable declaration is not necessary when using global variables in point job commands. Creating point job commands is easy if you define variables which are used frequently as global variables.

There are two types of global variable: the global non-keeping variable (referred to as *global variable* in this manual) and the global keeping variable (referred to as *keeping variable* in this manual). *Keeping* means that the variable will keep its value after the robot is turned off. Note that a value assigned to a global non-keeping variable will be lost if the robot is turned off, even while performing a point job.

You can choose between the numeric type and the string type, and set up to three dimensions in the variable array.

Select the following item while logged into the Customizing mode:

- TP** [Variable Definition]
 [Global Variables Definition] (Global non-keeping variable)
 [Keeping Variables Definition] (Global keeping variable)

- PC** [Customize] → [Global Variables] (Global non-keeping variable)
 [Customize] → [Keeping Variables] (Global keeping variable)

Item	Type	Description
Identifier	Identifier String	Character string used in the point job data formula: Specify the identifier when creating a new point type. Once specified, the identifier cannot be changed.
Protect Mode	Selection	Consists of the following four levels to protect data: 1. No Limit, 2. Public, 3. Protected, 4. Private
Variable Type	Selection	Select the type of variable from the following: 1. Numeric (8-byte (aka <i>double</i>) real type) 2. String (Up to 255 byte strings can be stored.)
Dimension	Selection	Select the dimension of the variable array from the following: 1. Element 2. 1 Dimension 3. 2 Dimension 4. 3 Dimension
Number of Element 1	Numeric	Number of array elements when the variable array is higher than 1 dimension.
Number of Element 2	Numeric	Number of array elements when the variable array is higher than 2 dimensions.
Number of Element 3	Numeric	Number of array elements when the variable array is higher than 3 dimensions.

USER FUNCTION DEFINITION

Using these settings to define the frequently used command lines simplifies the process. You can select either the function type or the numeric type and the string type and set up to three dimensions in the function array.

Select the following item while logged into the Customizing mode:

TP [User Function Definition]

PC [Customize] → [User Function]

Item	Type	Description
Identifier	Identifier String	Character string used in the point job data formula: Specify the identifier when creating a new point type. Once specified, the identifier cannot be changed.
Protect Mode	Selection	Consists of the following four levels to protect data: 1. No Limit, 2. Public, 3. Protected, 4. Private
Function Type	Selection	Select the type of variable from the following: 1. Numeric, 2. String
Argument Identifier	Identifier String	Dummy argument identifier: Function argument values are referred to and assigned in the function body using the dummy argument identifier.
Passing Type	Selection	1. Call by Value: An actual argument will be evaluated before evaluating a function and the argument value will be passed to the dummy argument. The value will not change even if the actual argument is a variable. 2. Call by Reference: Only variables can be actual arguments. The dummy argument reference will be evaluated as the actual argument variable reference. Assigning a value to the dummy argument will also be evaluated as assigning a value to the actual argument variable.
Argument Type	Selection	Select the type of argument from the following: 1. Numeric, 2. String
Dimension	Selection	Select the variable array dimension from the following: 1. Element 2. 1 Dimension 3. 2 Dimension 4. 3 Dimension
Number of Element 1	Numeric	Number of array elements when the variable array is higher than 1 dimension.
Number of Element 2	Numeric	Number of array elements when the variable array is higher than 2 dimensions.
Number of Element 3	Numeric	Number of array elements when the variable array is higher than 3 dimensions.
Function Body	Operation	Command lines that will be executed after being called

ALIAS

■ I/O Alias

I/O aliases are used to identify the function of each I/O pin. Define the input/output from the I/O-SYS and the I/O-1 including the data width. You can select the defined I/O pin as the output destination of *set*, *reset*, *dataIn*, and *dataOut* commands. (Select [IO-Alias] when selecting [Input/Output] during point job command teaching.)

For example, if the dispenser is connected to the #sysOut16 pin, set the #sysOut16 to [DISPENSE] using the alias settings and then register the point job as [set DISPENSE]. This setting is easy to understand and work with, and if you change the destination pin, you only need to change the alias settings and not the point job data command.

(To set the point job data command to [set DISPENSE], select [IO-Alias] when selecting [Output Destination] of the *set* command.)

Note that if you wish to set an alias to the I/O-SYS pin, check that the pin has been set to [Free] under [I/O-SYS Function Assignment] settings ([Run Mode Parameter] menu).

e.g. set #sysOut16 (I/O alias has not been set.)



set DISPENSE (#sysOut16 has been set to [DISPENSE].)

Select the following item while logged into the Customizing mode:

TP [Alias Definition]
[IO Alias Definition]

PC [Customize] → [Alias]

Item	Type	Description
Identifier	Identifier String	Character string used as the point job command or the sequencer command parameter. It is a kind of variable identifier but it is not used as a formula element. Specify the identifier when creating a new point type. Once specified, the identifier cannot be changed.
Protect Mode	Selection	Consists of the following four levels to protect data: 1. No Limit, 2. Public, 3. Protected, 4. Private
Caption	Multilingual String	Character string displayed as an item name on the point settings screen in the Teaching mode

Item	Type	Description
Default	IOM	Default value, i.e., value before any change or value which is set after deleting all data or resetting to the system default Specify the type (sysIn/genIn/handIn/sysOut/genOut/handOut/mv/mkv) and the number.
Default Data Width	Numeric	Default data width which is set using numeric values: Set the data width for use with the <i>dataOut</i> and <i>dataIn</i> commands. The data width is not necessary for other commands such as <i>ld</i> , <i>set</i> , and <i>reset</i> .
Direction	Selection	Selections in the Teaching mode will be limited as follows when either [Input] or [Output] is selected: 1. Input: sysIn/genIn/handIn/sysOut/genOut/handOut/mv/mkv 2. Output: sysOut/genOut/handOut/mv/mkv For example, if [Output] is selected, the input-only pins will not be displayed as the selections.
Data Width Setting	Selection	Select whether or not to enter the data width in the Teaching mode. Select [Invalid] if the data width is fixed to 1 or you do not wish to change the data width. 1. Valid: You can enter the data width in the Teaching mode. (Can be changed to [Invalid] later.) 2. Invalid: You cannot enter the data width in the Teaching mode.

■ COM Alias

COM aliases are used to identify the function of each COM port. Define the COM port using identifiers. You can use the COM alias to specify the COM port for the COM input/output commands (e.g. *outCOM*) in teaching. (Select [COM-Alias] when selecting [Input/Output] during point job command teaching.)

For example, if COM1 is connected to the PC, define COM1 as [PC] using the alias settings and then register the point job data command [eoutCOM PC,"ERROR"]. This setting is easy to understand and work with, and if you change the destination port, you do not need to change the point job data command.

(To set the point job data command [eoutCOM PC,"ERROR"], select [COM-Alias] when selecting [Output Destination] of the *eoutCOM* command.)

e.g. eoutCOM port1,"ERROR" (COM alias has not been set.)



eoutCOM PC,"ERROR" (COM1 has been set to [PC].)

Select the following item while logged into the Customizing mode:

TP [Alias Definition]

[COM Alias Definition]

PC [Customize] → [Alias]

Item	Type	Description
Identifier	Identifier String	Character string used as the point job command parameter: This is a kind of variable identifier but it is not used as a formula element. Specify the identifier when creating a new point type. Once specified, the identifier cannot be changed.
Protect Mode	Selection	Consists of the following four levels to protect data: 1. No Limit 2. Public 3. Protected 4. Private
Caption	Multilingual String	Character string displayed as an item name on the point settings screen in the Teaching mode
Default	Selection	Default value, i.e., value before any change, or value which is set after deleting all data or resetting to the system default: Select from the following: 1. COM1 2. COM2 3. COM3 4. TPU

POINT JOB/ADDITIONAL FUNCTION/SEQUENCER

Point job data Nos. 101 – 200, additional function data Nos. 51 – 100, and sequencer data Nos. 51 – 100 are handled as customizing data belonging to the owner.

The contents are the same as those created in the Teaching mode. The difference between them is that the customizing data belongs to the owner and can be protected in the protect mode.

For example, if you use the command lines which are commonly used in multiple point type definitions, you need to write the same command lines in each point type definition because the command lines need to be written directly into the point type definitions. This method is not efficient.

You can call the command lines as user-defined functions instead. However, it will be easier if you create the commands as point job data and then call the data using the *callJob* command. In this case, if you use the point job data Nos. 1- 100 created in the Teaching mode, you cannot protect the data because it does not belong to the owner.

When you wish to call point job data from the point type definition using the *callJob* command, use point job data Nos. 101 – 200 which belong to the same owner and can be protected in the protect mode (as well as additional function data Nos. 51 – 100, and sequencer data Nos. 51 – 100).

Select the following item while logged into the Customizing mode:

TP [Additional Function Data Settings]
[Point Job Settings]
[Sequencer Settings]

PC [Data] → [Point Job]
[Data] → [Additional]
[Data] → [Sequencer]

- If you are using a PC, log in to select point job data Nos. 101 – 200, additional function data Nos. 51 – 100, and sequencer data Nos. 51 – 100 in the same way as when selecting teaching data.

TEACHING MODE CUSTOMIZING

You can set the teaching mode customizing setting without logging in.

■ Caption

You can change the item name displayed in the Teaching mode. For example, if you set [Caption of Common Data Settings] to [Output Signal], [Common Data Settings] on the Teaching Mode Menu screen will be changed to [Output Signal] as illustrated below. (For screw tightening applications and soldering applications, the condition data settings caption is preset – [Screw Tightening Condition] and [Soldering Condition] – and cannot be changed.)

e.g. Caption of Common Data Settings (for Standard Applications)

Teaching Mode Menu		Teaching Mode Menu
Program Data Settings	➔	Program Data Settings
Common Data Settings		Output Signal
Additional Function Data Settings		Additional Function Data Settings
Point Job Settings		Point Job Settings
Sequencer Settings		Sequencer Settings
Run Mode Parameter		Run Mode Parameter
Teaching Data Copy, Delete, Conversion		Teaching Data Copy, Delete, Conversion
Default		After having set the caption [Output Signal]

Item	Type	Description
Caption of Usage	Multilingual String	Display in the Teaching mode
Caption of Condition Data Settings	Multilingual String	Condition data display in the Teaching mode
Caption of Common Data Settings	Multilingual String	Common data display in the Teaching mode
Caption of Program Data Settings	Multilingual String	Program setting variable display in the Teaching mode

TP

[Teaching Mode Customizing] (Customizing mode)

[Teaching Mode Display Settings]

[Caption of Usage]

[Caption of Condition Data Settings]

[Caption of Common Data Settings]

[Caption of Program Data Settings]

PC

[Set T.M.C.] → [Set Caption]

■ Display Sequence

You can set or change the display sequence on the teaching pendant LCD when selecting the point type or displaying the data settings in the Teaching mode.

Item	Type	Description
Order of Point Type	Identifier String	Settings for display sequence on the point type selection screen
Order of Condition Data	Identifier String	Settings for display sequence on the condition data settings screen
Order of Common Data	Identifier String	Settings for display sequence on the common data settings screen
Order of Program Data	Identifier String	Settings for display sequence on the settings screen for the program setting variable in the program data

The following example shows the point type selection screens for the standard applications in the Teaching mode ([Point Output] is the caption of the user-defined point type):

Select Item	Select Item
PTP Point	Point Output
CP Start Point	PTP Point
CP Passing Point	CP Start Point
CP Stop Point	CP Passing Point
CP Arc Point	CP Stop Point
CP End Point	CP Arc Point
PTP Evasion Point	CP End Point
Point Output	PTP Evasion Point

Default
After having set [Order of Point Type]
 (See next page for how to set)

TP [Teaching Mode Customizing] (Customizing mode)
 [Teaching Mode Display Settings]
 [Order of Point Type]
 [Order of Condition Data]
 [Order of Common Data]
 [Order of Program Data]

PC [Set T.M.C.] → [Set View Order]

Select the item you wish to change the order of:

Press the **F.3** (UP) key to move the selected item up by one line.

Press the **F.4** (DOWN) key to move the selected item down by one line.

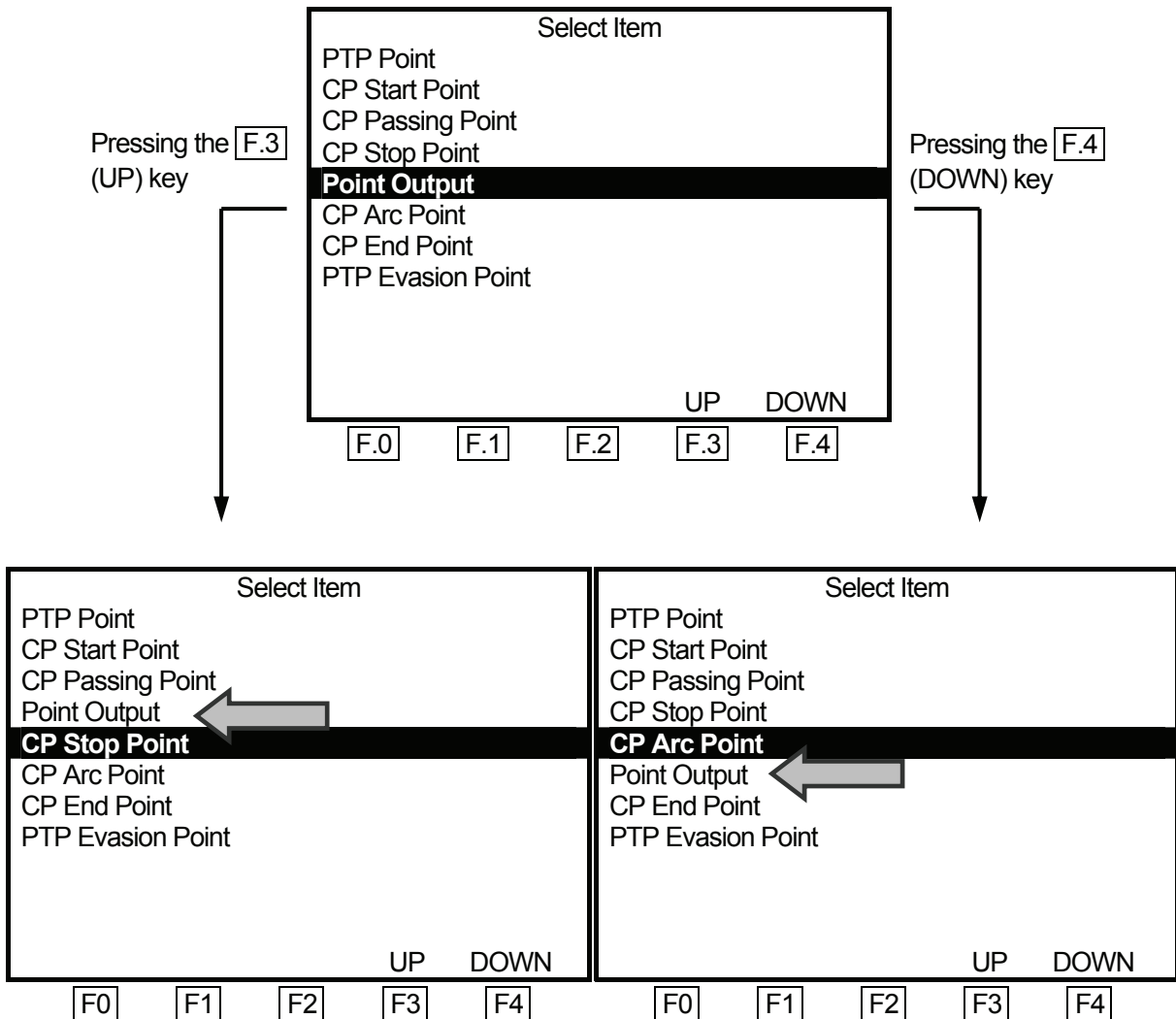

■ Menu Items

You can hide the following items on the Teaching Mode menu screen. Set [Invalid] to the unnecessary items.

Item	Type	Description
Point Job Settings	Selection	1. Valid, 2. Invalid
Additional Function Data Settings	Selection	1. Valid, 2. Invalid
Sequencer Settings	Selection	1. Valid, 2. Invalid
Run Mode Parameter	Selection	1. Valid, 2. Invalid

The following screens show an example using [Point Job Settings]:

Teaching Mode Menu	Teaching Mode Menu
Program Data Settings	Program Data Settings
Common Data Settings	Common Data Settings
Additional Function Data Settings	Additional Function Data Settings
Point Job Settings	Sequencer Settings
Sequencer Settings	Run Mode Parameter
Run Mode Parameter	Teaching Data Copy, Delete, Conversion
Teaching Data Copy, Delete, Conversion	

[Point Job Settings] is set to [Valid].

(Default setting)

[Point Job Settings] is set to [Invalid].

TP

[Teaching Mode Customizing] (Customizing mode)

[Teaching Mode Display Settings]

[Point Job Settings]

[Additional Function Data Settings]

[Sequencer Settings]

[Run Mode Parameter]

PC

[Set T.M.C.] → [Set Menu YN]

■ Default

Default Program Data

When you add a new program, the values set under this setting will be the default program data values. Using this setting, you do not need to enter the same program data values repeatedly if they are used in multiple programs.

TP [Default Program Data] (Customizing mode)

PC [Set T.M.C.] → [Program Data Default]

- Program data values in the registered programs will not be changed using this setting.

Default Run Mode Parameter

If you perform [Reset Run Mode Parameter] (under [Teaching Data Copy, Delete, Conversion] in the Teaching Mode menu), the values set under this setting will be the default Run mode parameter values.

TP [Default Run Mode Parameter] (Customizing mode)

PC [Set T.M.C.] → [Run Mode Parameter Default]

- Run mode parameters currently used will be changed only after setting this and performing [Reset Run Mode Parameter].

DATA SAVE

When saving data, save the teaching data along with the customizing data. This unit of saved data is referred to as *C & T data*.

If the PC is connected to the robot, send data to the robot using the PC software JR C-Points. The data sent from the PC will be stored in the robot automatically.

If the teaching pendant is connected to the robot, press the **SAVE** key.

All the C & T data created using the teaching pendant is stored in the robot temporarily; however, **it will be deleted automatically when the robot is turned off**. Be sure to press the **SAVE** key whenever the teaching data and customizing data has been modified.

To back up the data, send the C & T data from the robot to the PC using the PC software JR C-Points or JR C-Points Limited Edition.

MEMO

Janome Sewing Machine Co., Ltd.

Industrial Equipment Sales Department

Postal Code: 193-0941

1463 Hazama-machi, Hachioji-shi, Tokyo, Japan

Tel: +81-42-661-6301

Fax: +81-42-661-6302

The specifications of the robot or the contents of this manual may be modified without prior notice to improve its quality.

No part of this manual may be reproduced in any form, including photocopying, reprinting, or translation into another language, without the prior written consent of JANOME.

©2009, JANOME Sewing Machine Co., Ltd., All rights reserved.

970805100 as of 2007-07

8 January 2009