

JANOME DESKTOP ROBOT

JR2000N Series

Operation Manual

Setup

(For Installation Operators)

Installation operators are persons who have undergone installation training at Janome or at a representative branch. People responsible for installation work should complete this training.

Thank you for purchasing this Janome Robot.

- Before using your robot, read this manual thoroughly and always make sure you use the robot correctly. In particular, be sure to thoroughly read “For Your Safety” as it contains important safety information.
- After reading this manual, store in a safe place that can be easily accessed at any time by the operator.
- This manual is written according to IEC 62079.

JANOME

PREFACE

The Janome Desktop Robot JR2000N Series are new low-cost, high-performance robots. With these robots we succeeded in reducing the price while maintaining functionality. The combined use of stepping motors and specialized micro step driving circuits saves both energy and installation space. There are several manuals pertaining to these robots.

Setup	Explains how to set up the robot. ■ Make sure you read this manual ■ <u>NOTE:</u> This manual is designed for people who have received safety and installation training regarding the robot.
Maintenance	Explains maintenance procedures for the robot. ■ Make sure you read this manual ■ <u>NOTE:</u> This manual is designed for people who have received safety and maintenance training regarding the robot.
Basic Instructions	Provides part names, data configurations, and the basic knowledge necessary to operate the robot.
Quick Start	Explains the actual operation of the robot by creating and running simple programs.
Teaching Pendant Operation	Explains how to operate the robot via the teaching pendant.
PC Operation	Explains how to use the PC software, JR C-Points.
Functions I	Explains point teaching.
Functions II	Explains commands, variables, and functions.
Functions III	Explains functions such as Run Mode parameters and sequencer programs.
Functions IV	Explains functions in Customizing Mode.
External Control I (I/O-SYS)	Explains I/O-SYS communication control.
External Control II (COM Communication)	Explains COM1 – COM3 communication control.
Camera/Sensor	Explains the functions of the attachable camera and Z position sensor.
Specifications	Outlines general specifications such as the robot's operating range, weight, etc.
Application Specifications	Explains the specialized functions of the various application specifications.

Note: Product specifications are regularly updated; therefore the content of this manual may differ from the robot in your possession. Additionally, the menu items displayed on the TP and PC may vary from those listed in this manual.

The descriptions within this manual are based on standard specifications. The menu item names etc. may vary depending on the model type.

Attention

To make full use of the machine's functions and capabilities, make sure that you use the robot according to the correct handling/operation procedures that are written in this manual. Do not handle or operate the robot in ways not covered in this manual.

Attention

If you turn OFF the power after making changes to robot's settings or data without saving, these changes are lost and the robot will revert to its original settings. Make sure that you save any changes to data and/or settings.



Warning

Make sure that the **machine is grounded and do not use the machine if it is not grounded**. Make sure that the **ground resistance of the robot power supply is 100Ω or less**.

Using the machine without sufficient grounding can cause electric shock, fire, accidental operation and machine breakdown.



Warning

Make sure that the machine power supply is OFF before connecting the power cord.

Failure to do so could cause electric shock and/or injury.

Note: The operation methods described in this manual are indicated as follows:



TP Operation via the teaching pendant



PC Operation via PC (JR C-Points)

RESPONSE TO EC/EU DIRECTIVES

This robot is a semi-finished product, and includes a declaration to the EC/EU directives.

Janome implements its conformity testing through a third certification authority for each of the EMC, LVD, MD directives.

The applicable requirements of the MD and EMC Directives vary depending on the machine settings and systems. We conduct general confirmation tests through a model setup. Conduct your own final confirmation tests and risk assessments of your machine and its setup and make sure that it conforms to the MD and EMC Directives.

CONTENTS

PREFACE	1
CONTENTS.....	3
FOR YOUR SAFETY	4
1. SYSTEM CONFIGURATION.....	9
2. INSTALLATION.....	10
2.1 Common to the JR2200N(NE) Series.....	11
2.2 Common to the JR2300N(NE) Series.....	12
2.3 Common to the JR2400N(NE) Series.....	13
2.4 Common to the JR2500N(NE) – JR2600N Series.....	14
2.5 X-Table Workpiece Center of Gravity.....	15
2.6 Teaching Pendant Hanging Ring	16
2.7 Cable Connection	17
2.7.1 JR2200N(NE) Series (rear view)	17
2.7.2 JR2300N(NE) – JR2600N Series (rear view).....	18
2.7.3 Power Grounding.....	21
2.7.4 Connecting to a PC.....	22
3. BACKING UP INDIVIDUAL CONFIGURATION INFORMATION.....	26
4. BACKING UP C & T DATA.....	27
5. DOWNLOADING THE ROBOT SYSTEM SOFTWARE.....	29
6. SETTINGS NEEDED FOR TEACHING	30
6.1 4-Axes: Tool Data.....	30
6.2 Work Weight	31
7. SETTINGS NEEDED TO MAKE A RUN.....	32
7.1 External Run Mode Settings.....	32
7.2 Setting Program Numbers.....	33
7.2.1 Changing Program Numbers.....	33
7.2.2 Program Number Reading Code.....	33
7.2.3 Program Number Changing Method	34
7.3 I/O-S Settings (CE specification models only).....	35
8. HOW TO CONVERT THE DATA FROM JR2000 INTO JR2000N.....	36

Attention

When using this robot for the first time, be sure to back up the individual configuration information and create an individual configuration information backup file. Robot individual configuration information is needed when replacing the internal circuit boards.

FOR YOUR SAFETY



The safety notes outlined below are provided in order to ensure safe and correct usage of the product in addition to preventing injury to the operator, other people and damage to property as well.

• • • • • Be sure to follow the safety guidelines detailed here • • • • •











Symbols are also listed alongside the safety note explanations. Refer to the list below for an explanation of these symbols.

Symbols that indicate the level of danger and/or damage.

The level of danger or damage that could occur as a result of ignoring these safety guidelines and misusing the robot are classified by the following symbols.

 Danger	This symbol indicates an imminent risk of serious injury or death.
 Warning	This symbol indicates a risk of serious injury or death.
 Caution	This symbol indicates the possibility of serious injury or damage to property.

The following symbols list the nature of the danger and any necessary safety methods to be taken.

	Indicates caution must be taken
	Take Caution (General Precaution)
	Indicates a forbidden action
	Never do this (General Prohibition)
	Do not disassemble, modify or repair.
	Do not touch (Contact Prohibition)
	Indicates a required action
	Be sure to follow instructions (General Requirement)
	Be sure to unplug the power cord
	Make sure the machine is grounded

FOR YOUR SAFETY

Danger



Do not use where flammable or corrosive gas is present.

Leaked gas accumulating around the unit can cause fire or an explosion.

Warning



Make sure that you securely install the unit in a place that can withstand both the mass of the machine and the usage conditions.

In addition, **for units with a cooling fan on the back, allow for 30cm or more clearance between the back of the unit and the wall.** If installation is inadequate, the unit may drop or fall over causing injury and/or unit breakdown.



Make sure to power the unit within its rated current range.

Failure to do so may cause electric shock, fire, or unit malfunction.



Plug the power cord into the power outlet firmly.

Failure to do so may cause the plug to heat up and may result in fire.



Be sure to use the unit within its indicated voltage range.

Failure to do so may cause fire or unit malfunction.



When inspecting or lubricating the unit, unplug the power cord from the power outlet, then remove the cord from the main unit and make sure there is no electrical current. Also, do not touch any of the power inlet pins within 5 seconds of removing the power cord. Failure to follow these steps causes electric shock or injury.

FOR YOUR SAFETY

Warning



Always make sure the unit is grounded to avoid possible electrical shocks. Do not use when the unit is not grounded.

Improper grounding may cause electric shock or fire.



Wipe the power plug with a clean, dry cloth periodically to eliminate dust.

Dust accumulation may deteriorate the electrical insulation and cause fire.



Be sure to unplug the power cord from the power outlet when the unit is not in use for long periods of time.

Dust accumulation may cause fire.



Be sure to turn OFF the unit before inserting or removing cords and cables such as the teaching pendant cable.

Failure to do so may result in electric shock, fire, data loss, or unit malfunction.



Do not attempt to disassemble or modify the unit.

Disassembly or modification may cause electric shocks or unit malfunction.



Do not allow water or oil to come in contact with the unit, control box or the power cord.

Contact with water or oil may cause electric shock, fire, or unit malfunction.

IP Protection Rating: IP30 (CE specifications : IP40)



If anything unusual occurs, such as a burning smell or unusual sound, stop operation and unplug the power cord immediately. Contact the dealer from whom you purchased the robot or the office listed on the last page of this manual.

Continuing to use the robot without addressing the problem may cause electric shock, fire, or unit breakdown.

FOR YOUR SAFETY

Caution



Do not drop or jar the unit during transport and/or installation.

This could cause injuries or damage the unit.



Before performing any operation, ensure there is no imminent danger to any of the operators. Failure to do so may result in injury.



Use the unit in an environment between 0 and 40°C, with a humidity level of 20 – 90%, and without condensation.

Use outside of these conditions may result in unit malfunction or breakdown.

IP Protection Rating: IP30 (CE specifications: IP40)



Use the unit in an environment where no electrical noise is present.

Failure to do so may result in unit malfunction or breakdown.



For models with I/O-S circuits, when installing the unit, take safety measures such as setting up area sensors and an enclosure.

If there are no safety measures in place and someone enters the area of operation when the robot is running, they may be injured.



Keep the emergency stop switch within reach of the operator when running or operating the robot.

If the robot is operated when the emergency switch is not within reach, it may not be possible to stop the robot immediately and safely. This is potentially dangerous.



Make sure that you regularly perform a function check for the emergency stop switch. Also, for models with I/O-S circuits, regularly perform an I/O-S circuit function check.

If you perform work without making a circuit check, you or the operator will not be able to immediately and safely stop the robot in an emergency. This is potentially dangerous.

FOR YOUR SAFETY

Caution



When attaching tools make sure they are securely fitted before running the robot. Failure to do so causes injury or breakdown.



When using the machine for extended periods of time, check and make sure none of the main unit's mounting screws are loose, and perform a routine inspection every 3 months. Failure to do so causes injury or breakdown.



Be sure to check the connections of the cords and cables to the main unit. Improper wiring may result in unit malfunction or breakdown.



Be sure to secure the movable parts of the unit before transportation. Failure to do so may result in injury or breakdown.



When lifting and transporting the robot, do so with 2 or more people. Failure to do so causes injury or breakdown.



Use the unit in an environment that is not exposed to direct sunlight. Direct sunlight may cause unit malfunction or breakdown.



Individual Configuration Information varies for each individual unit even if they are the same model. **Do not use backup data with a different robot. The robot cannot function normally with backup data from a different robot.**

1. SYSTEM CONFIGURATION

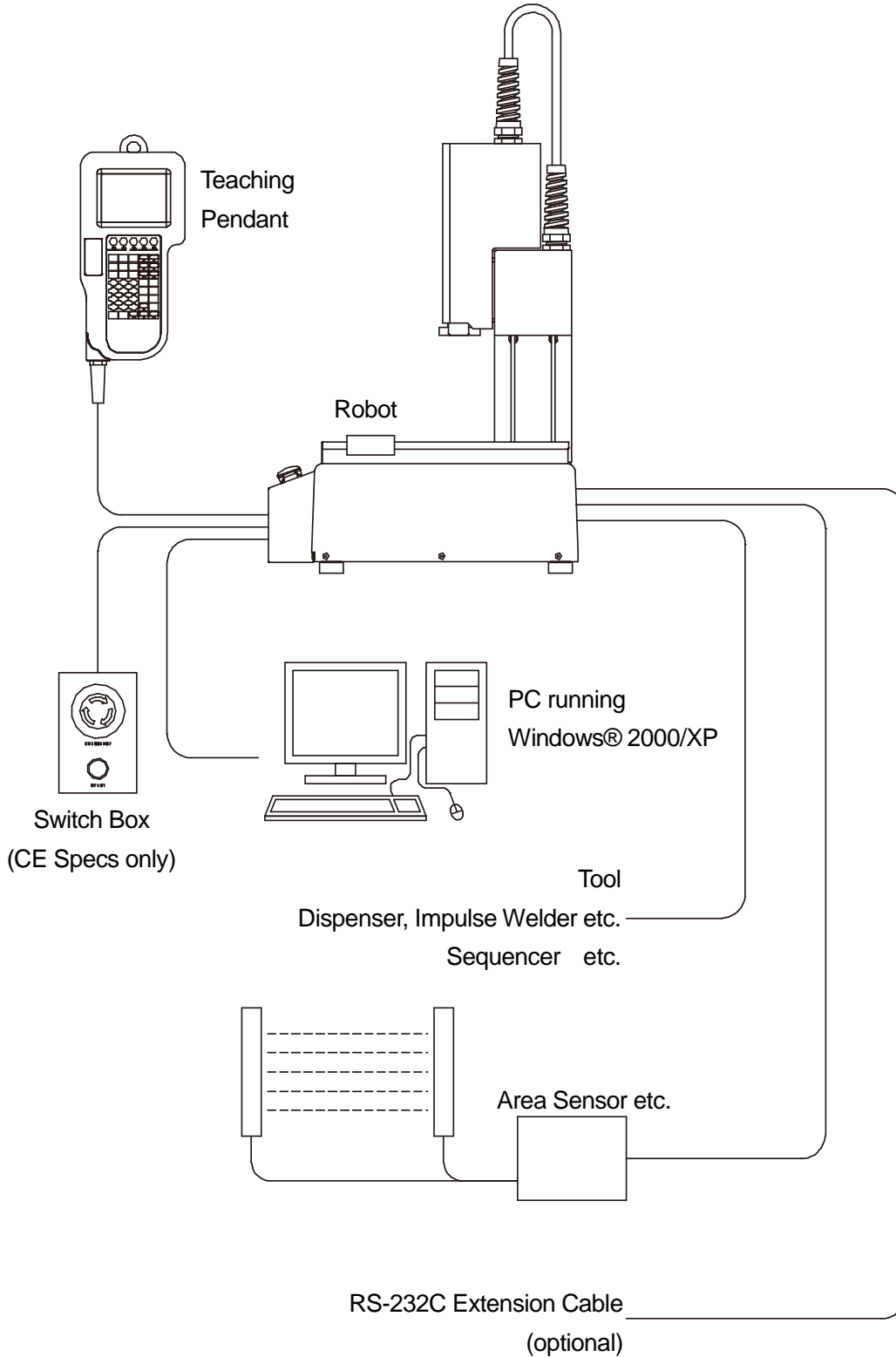

Windows® is a registered trademark of Microsoft.

2. INSTALLATION

Danger



Do not use where flammable or corrosive gas is present.
Leaked gas accumulating around the unit causes explosions and fire.

Warning



Do not drop or jar the unit during transport and/or installation.
This could cause injuries or damage the unit.



Use the unit in an environment between 0 and 40°C, with a humidity level of 20 – 90%, and without condensation.
Use outside of these conditions can cause unit malfunction.
IP Protection Rating: IP30 (CE specifications: IP40).



Use the unit in an environment where no electrical noise is present.
Failure to do so causes unit malfunction or breakdown.



Use the unit in an environment that is not exposed to direct sunlight.
Direct sunlight causes unit malfunction or breakdown.



Make sure that you correctly install the unit in a place that can fully withstand both the unit's weight and its usage.
Install the robot 60cm or higher above floor level and in the center of the work bench.
Do not install on an unstable workbench. If the installation is inadequate, the unit may fall or overturn causing injury and/or unit breakdown.



For units with a cooling fan on the back, allow 30cm or more clearance between the back of the unit and the wall. Failure to do so may cause overheating or fire.

When installing, rotate the rubber feet to adjust the height. Be sure to make them stable.

2.1 Common to the JR2200N(NE) Series

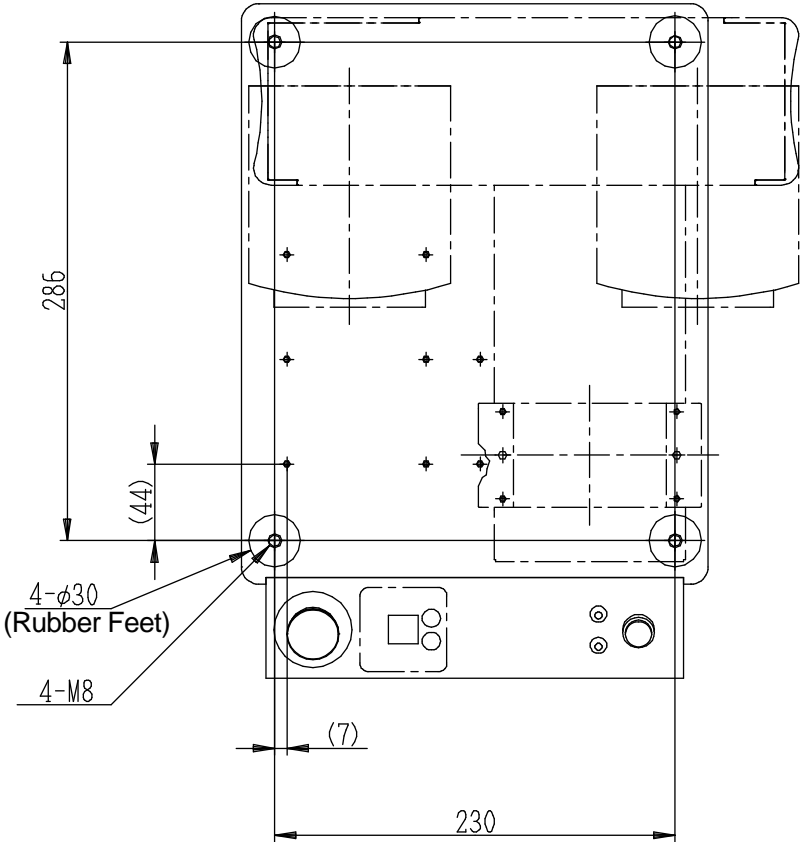

There are four rubber feet (φ30).

The values within the brackets above are for reference only and vary depending on unit assembly.

NOTE

- The robot may rattle depending on the tool weight. If so, be sure to secure the unit. To secure the unit, use the M8 screws in the 4 places that fasten the rubber feet.
- Have at least 2 people carry the unit when transporting it. (Weight: approx. 18kg).

2.2 Common to the JR2300N(NE) Series

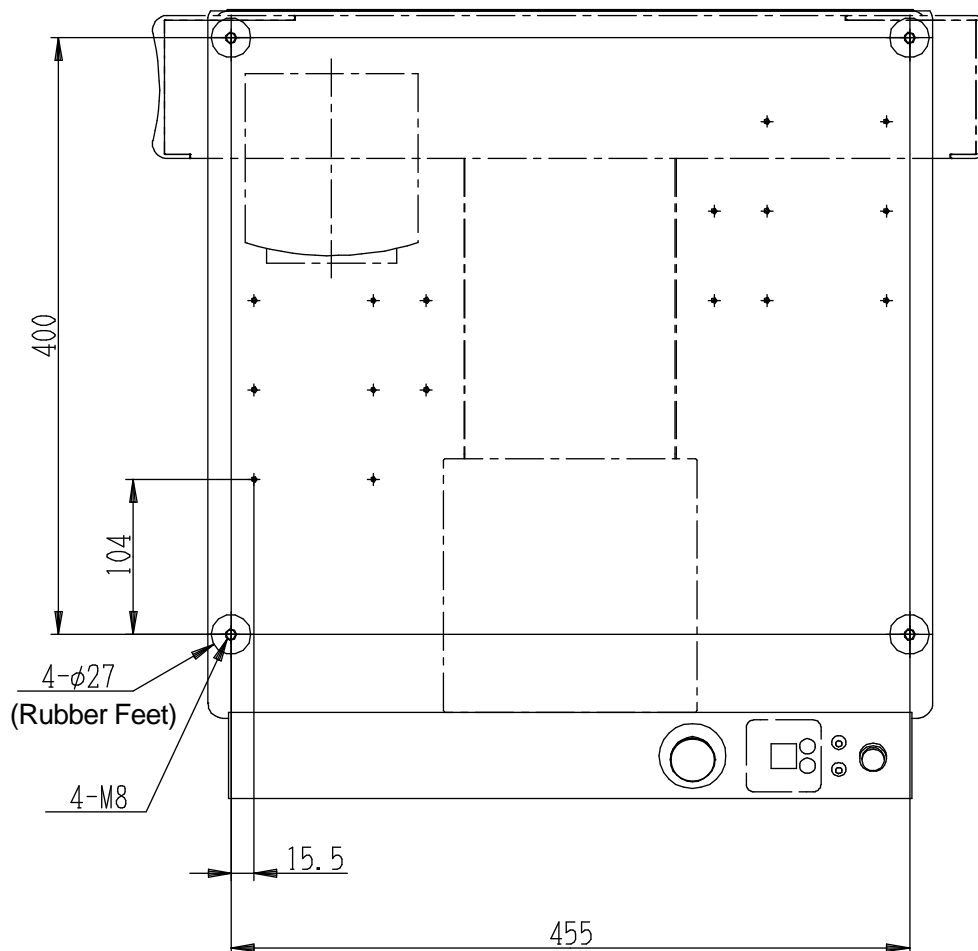

There are four rubber feet ($\phi 27$).

NOTE

- The robot may rattle depending on the tool weight. If so, be sure to secure the unit. To secure the unit, use the M8 screws in the 4 places that fasten the rubber feet, and use spacers with a height of 20mm or more (due to protrusions).
- Have at least 2 people carry the unit when transporting it or use a lifter. (Weight: approx. 35kg).

2.3 Common to the JR2400N(NE) Series

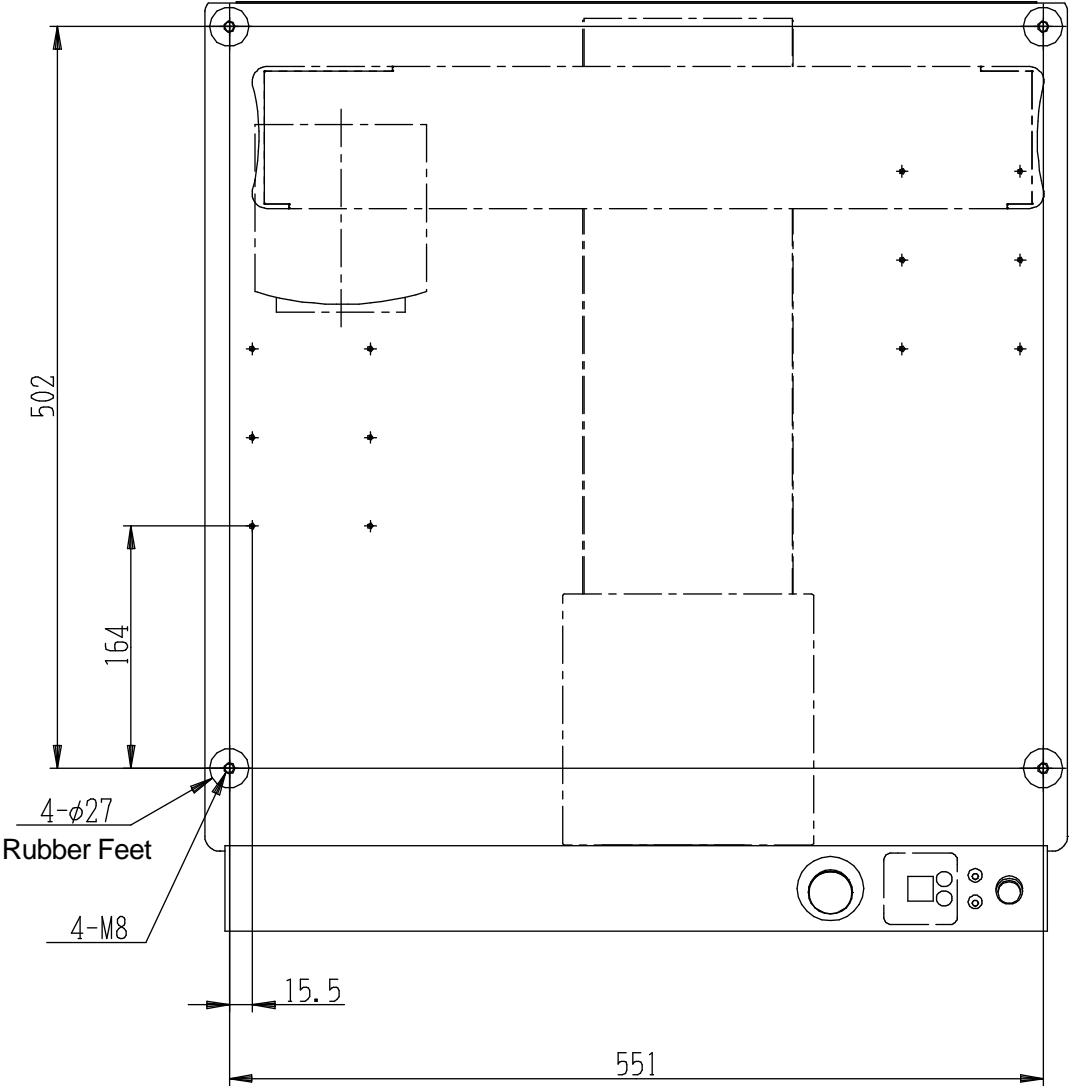

There are four rubber feet (φ27).

NOTE

- The robot may rattle depending on the tool weight. If so, be sure to secure the unit. To secure the unit, use the M8 screws in the 4 places that fasten the rubber feet, and use spacers with a height of 20mm or more (due to protrusions).
- Use a lifter to transport the unit. (Weight: approx. 42kg).

2.4 Common to the JR2500N(NE) – JR2600N Series

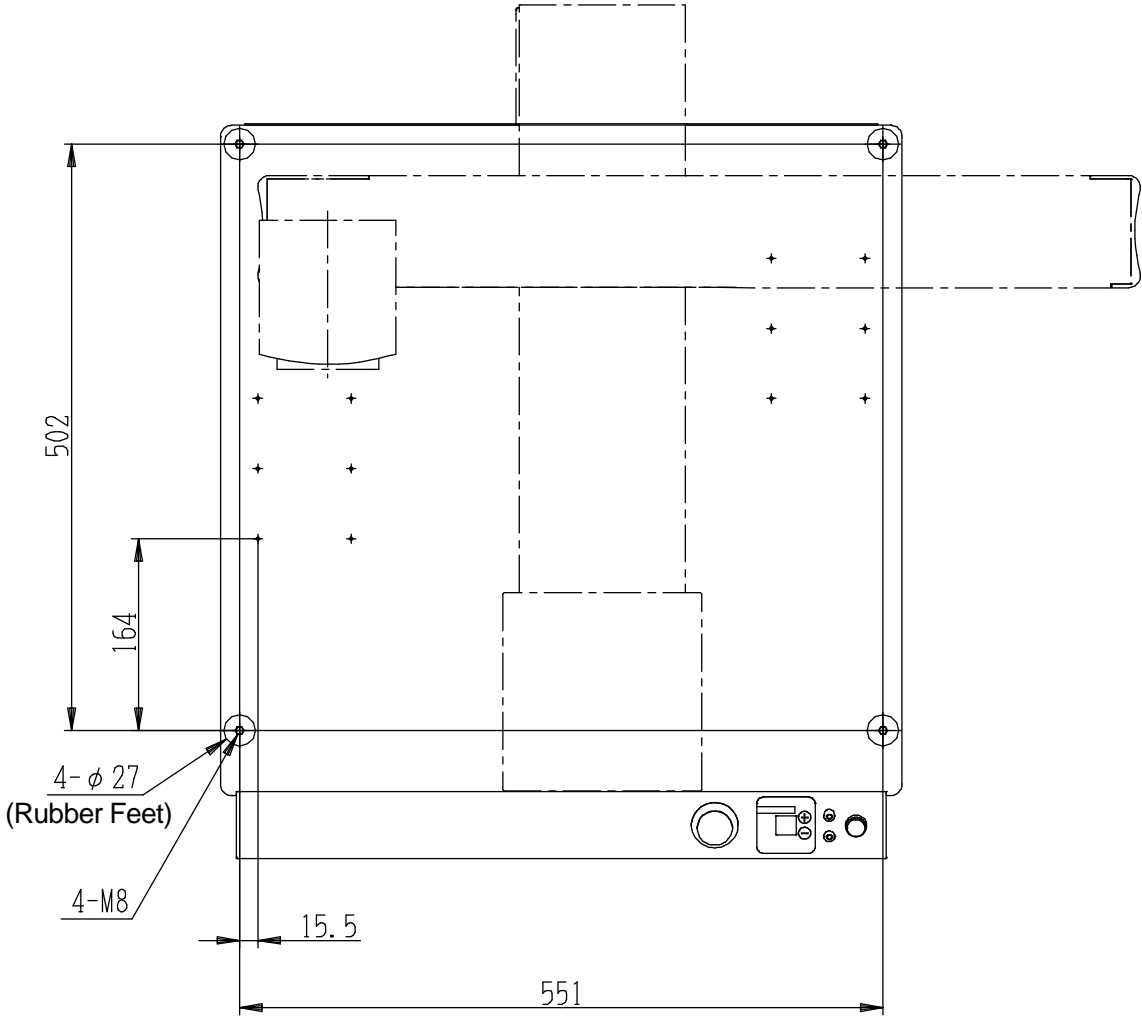

There are four rubber feet ($\phi 27$).

NOTE

- The robot may rattle depending on the tool weight. If so, be sure to secure the unit. To secure the unit, use the M8 screws in the 4 places that fasten the rubber feet, and use spacers with a height of 20mm or more (due to protrusions).
- Use a lifter to transport the unit. (JR2500N(NE) weight: approx. 46kg), (JR2600N weight: approx.. 48kg)

2.5 X-Table Workpiece Center of Gravity

The workpiece center of gravity should be centered on the X-table as best as possible. Also make sure the workpiece height is as low as possible to reduce the moment load.

If a position discrepancy (motor step out) occurs during operation, reduce the acceleration and/or speed.

As reference, performance testing was done using the loads in the table below:

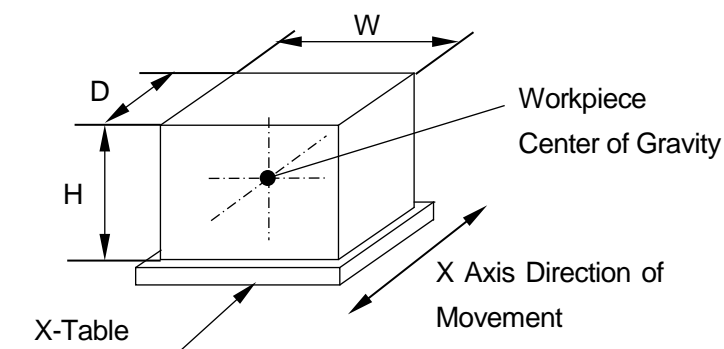

Workpiece Mass: Confirmed using the maximum portable mass

Model	Workpiece	W	H	D	H/2 Center of Gravity Height
JR2200N – JR2600N	7 Kg	150	120	50	25

Material: S45C equivalent

Unit: millimeter(mm)

2.6 Teaching Pendant Hanging Ring

You can attach the hanging ring included in the package to the teaching pendant to hang it up. Also, if you are using the teaching pendant as a monitor during use in Run Mode, install at an easy to operate height of 60cm or higher from the ground.

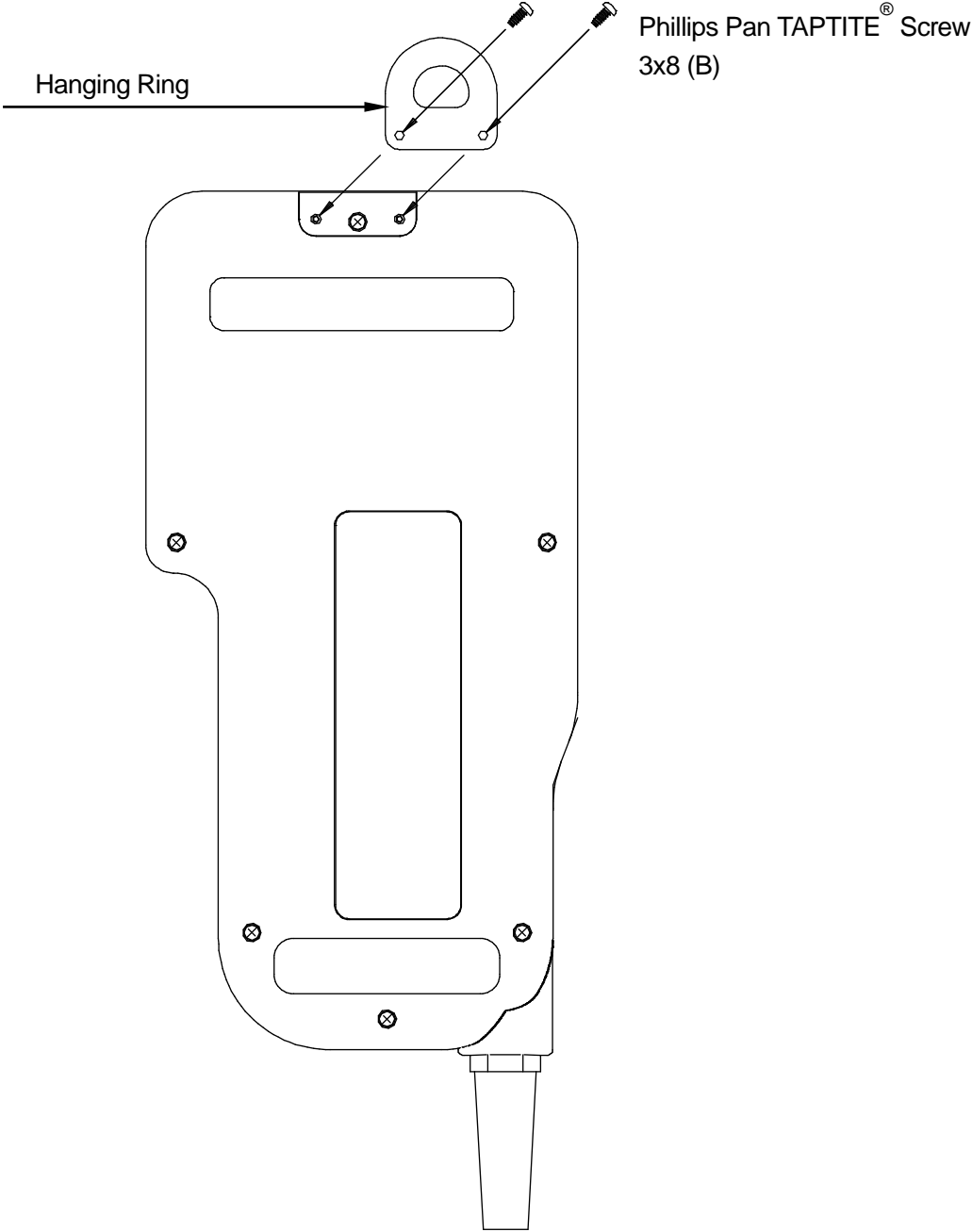

Teaching Pendant Rear View

2.7 Cable Connection

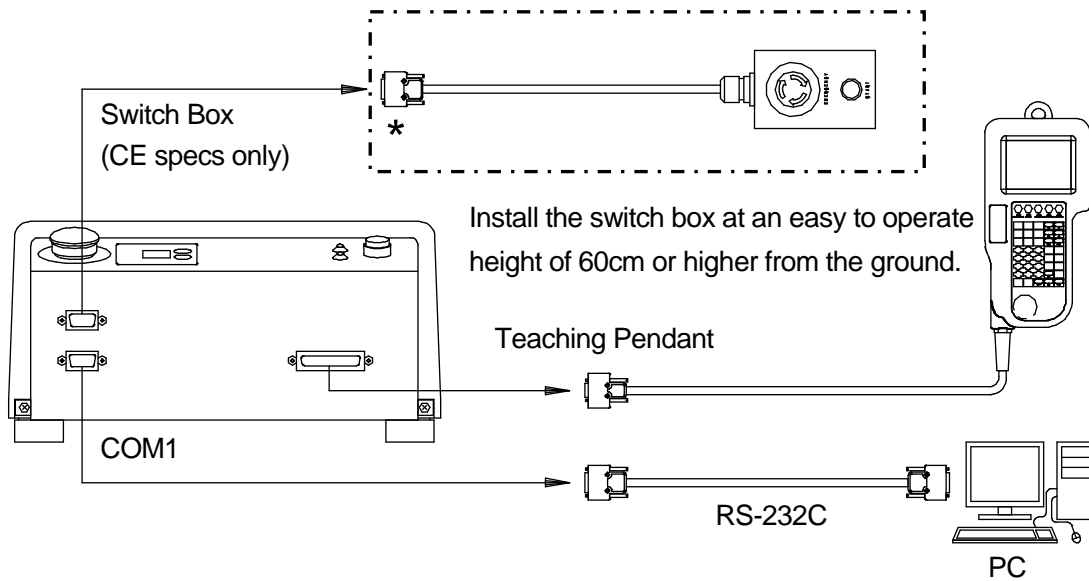

2.7.1 JR2200N(NE) Series (rear view)

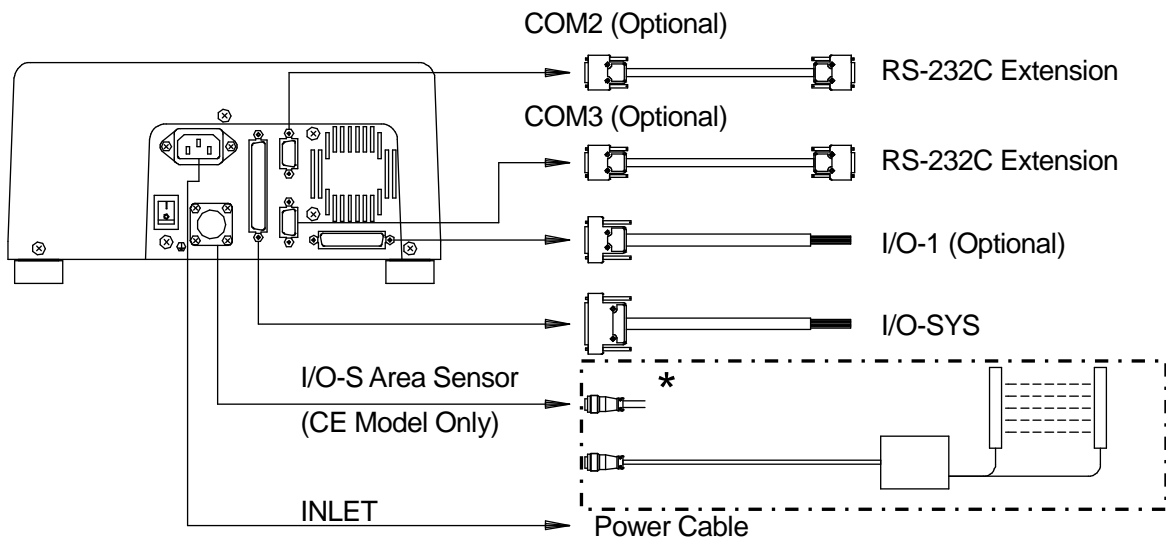

Attention

If you are using a CE specification model and are not using the parts indicated by asterisks, connect the two I/O-S connectors instead. (Be sure to short-circuit the lead wires.) The robot will not run if nothing is connected. Always use dust covers on unused connectors (except the outlet) to prevent any trouble with static electricity or dust.

2.7.2 JR2300N(NE) – JR2600N Series (rear view)

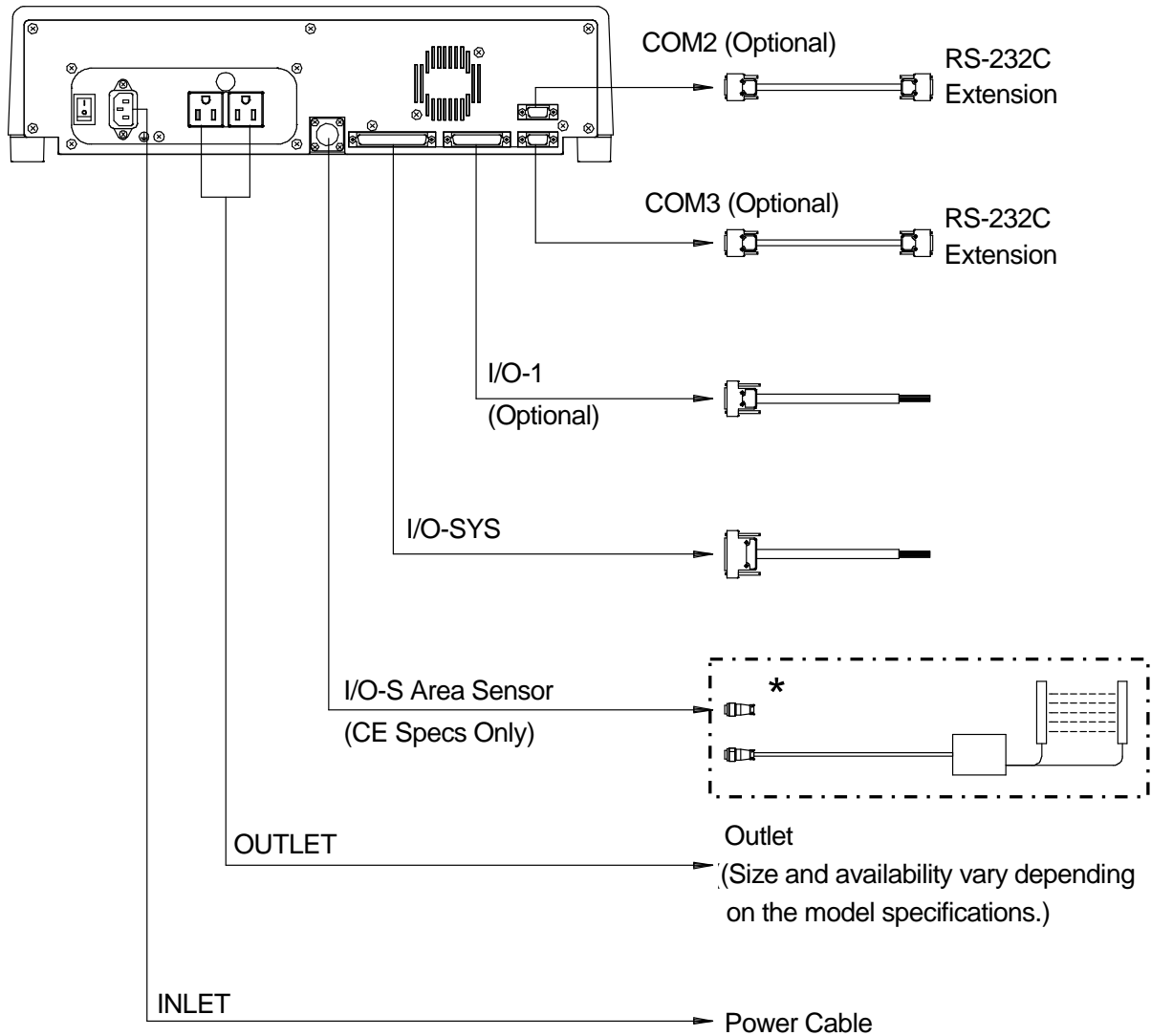

Caution

The cord for connecting to the outlet is a cord especially for industrial machinery. Do not modify in any way. Modifying the cord can result in electric shock or injury.

Attention

If you are using a CE specification model and not using the part indicated by the asterisk, connect the two I/O-S connectors instead. (Be sure to short-circuit the lead wires.) The robot will not run if nothing is connected. Always use dust covers on unused connectors (except the outlet) to prevent any trouble with static electricity or dust.

For information regarding connecting an external device via I/O-SYS refer to the operation manual *External Control I*, for connecting via COM1 refer to “2.6.4 Connecting to a PC” in this manual, and for all other connections refer to the operation manual *Specifications*.

Connector Mark		Connecting Cable	Connecting Device
I/O-SYS		I/O-SYS cable (I/O Cable)	PLC
		2m 984937002	Various tools
		3m 984837105	
		5m 984937208	
	Connector 960537004		
I/O-1 (Optional)		I/O-1 cable (I/O2 Cord)	Various tools
		2m 982544002	
		Connector 961513007	
COM1		RS-232C (Straight) D-SUB 9 Pin socket type Not included.	PC or PLC etc. Not included.
COM2(optional) COM3 (optional)		RS-232C (Straight) D-SUB 9 Pin socket type Not included.	For extensions (Camera etc.)
SWITCH BOX	CE Specs	Integral to the switch box.	1m 960530007 1.5m 960530018
TEACHING PENDANT		Integral to the teaching pendant.	963661007 With emergency stop switch 963661100
I/O-S	CE Specs	I/O-S connector 963525008 Modify the short connector	Area Sensor Safety Guard Switch etc. Not included.
INLET		Domestic 952801007 100V (North America etc.)	Power supply: Single-phase 90 – 132V 50/60Hz
		982559004 CE (200V) 80543005 UK (200 V) 982544006	
OUTLET (JR2200N Series is not equipped with an outlet.)		The connecting cord is an industrial type cord. Do not modify.	The power supply spec is the same as the power supplied from the INLET. MAX: 3A

NOTE: The power cord may vary depending on the model specifications.

JANOME'S RESPONSE TO EC DIRECTIVES

This robot is a semi-processed product, and includes a declaration to the EC directive. Janome implements its conformity testing via a third-party certification for each of the EMC, LCD, MD directives.

Attention

The applicable requirements of the MD and EMC Directives vary depending on the machine settings and systems. We conduct general confirmation tests through a model setup. Conduct the final confirmation tests and risk assessments of your machine and overall setup to make sure it conforms to the MD and EMC Directives.



Do not plug or remove the teaching pendant while the power is ON. Doing so can damage the device and/or cause a malfunction. Additionally, only connect teaching pendants with options/without options to the compatible robot. Connecting an incompatible teaching pendant can cause robot breakdown.

If the screen below is displayed when the power is turned ON, make sure the connected teaching pendant and its specifications (whether or not it has an emergency switch and/or enable switch) are compatible with your robot. If you are using the appropriate teaching pendant and this screen is still displayed, the teaching pendant is likely to be faulty.

Contact Janome (listed on the back page of this manual) or your local dealer.

Wrong Teaching Pendant Type
Turn off and Connect the Right
Pendant as follows

Emergency Switch N
Enable Switch N

NOTE: These are example teaching pendant specifications

NOTE: Even if “Hit Any Key” is displayed, do not press any of the keys.

2.7.3 Power Grounding

If you are using the power cord supplied with the robot, ensure to plug the cord in firmly. The power cord also acts as a ground.

If you can't connect the ground through the power cord, connect using grounding screws and also use a ground power resistance of less than 100Ω .

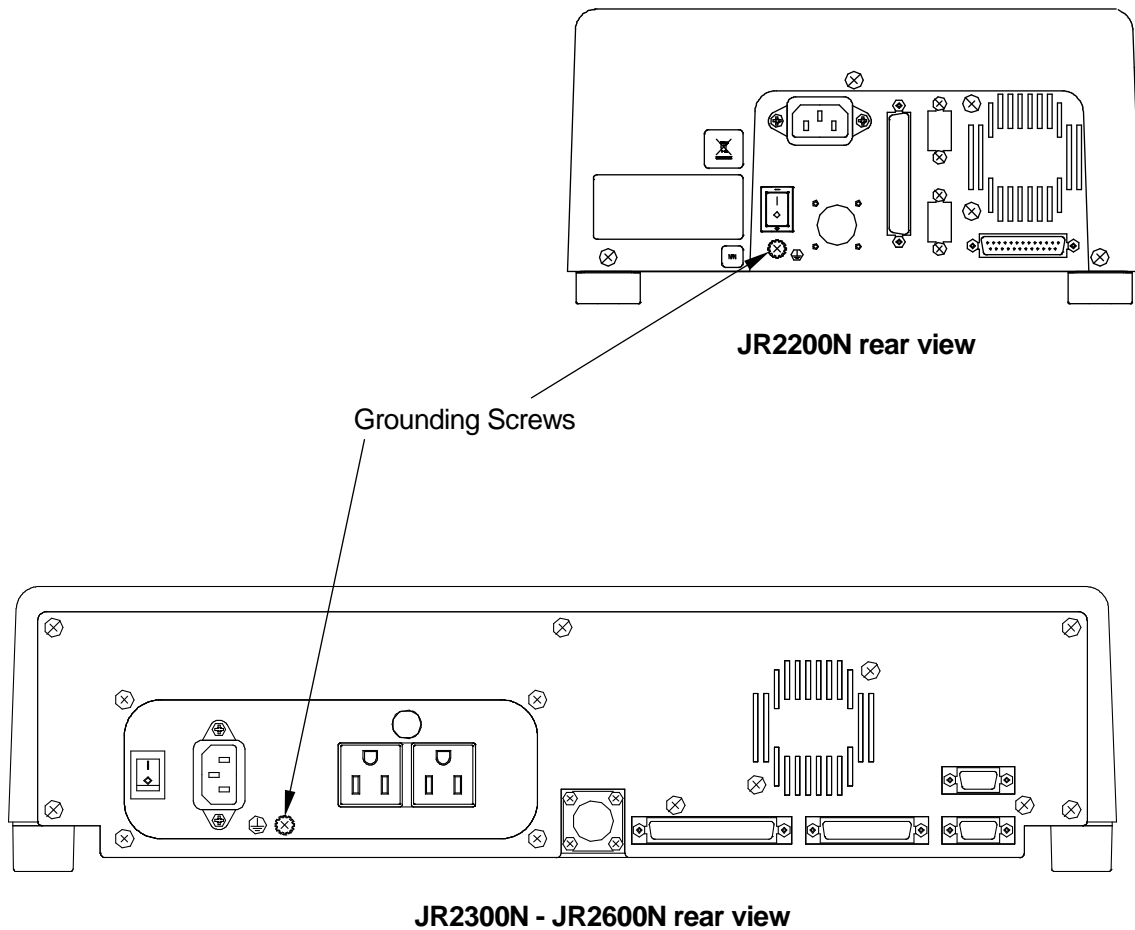

Caution

Always **connect the ground**. Do not use the robot when the **ground is not connected**. Make sure the robot's **ground power resistance is 100Ω or less**.

Incomplete grounding can result in electric shock, fire, malfunction or unit breakdown.

2.7.4 Connecting to a PC

To back up the robot's C&T data and system software, connect the robot to a PC. Make sure they can interface.

To connect, an RS-232C Straight Cable is required as shown below.

Note: The wiring diagram for the interfacing cable for COM connections (RS-232C) is on the next page.

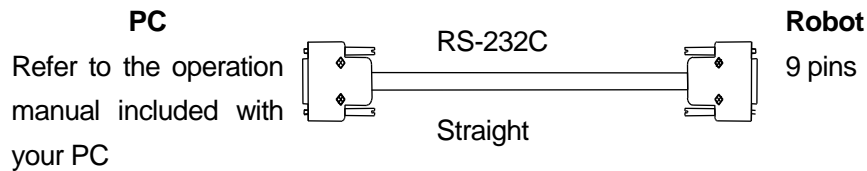

Attention

Make sure the power to both the robot and the PC are OFF before attaching or removing the cable. Failure to do so can cause a breakdown.

Respectively insert the two ends of the above RS-232C cable into the COM 1 connector on the robot and the COM port on the PC (serial connector/RS-232C).

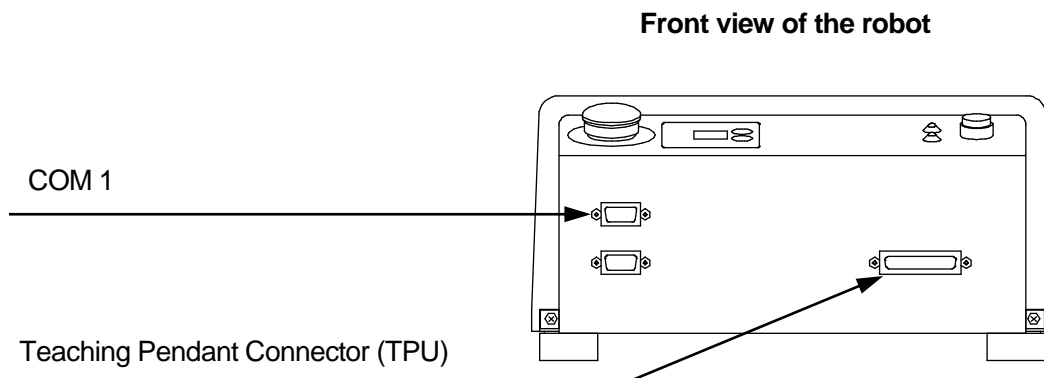

NOTE

If you are using JR C-Points (optional) to operate the robot from the PC, remove the teaching pendant. (If you are using a teaching pendant with an enable switch or an emergency stop switch, connect a grip switch (optional) to the teaching pendant connector.)

■ Interfacing cable wiring diagram (for COM: RS-232C)

The connector on the robot's side is a 9 pin, D-SUB connector.

For the COM (RS-232C port) use a straight cable. Reverse type or cross type cables cannot be used.

■ 9 pin D-SUB connector on the host (PC) side

COM1 (RS232C port)

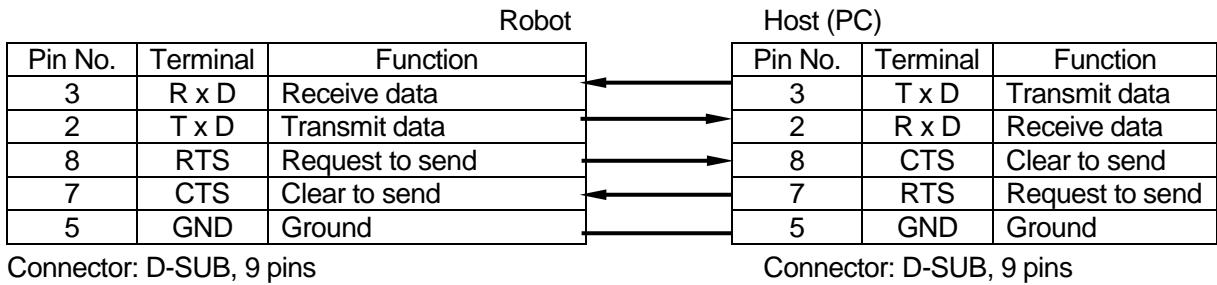

■ 25 pin D-SUB connector on the host (PC) side

COM1 (RS232C port)

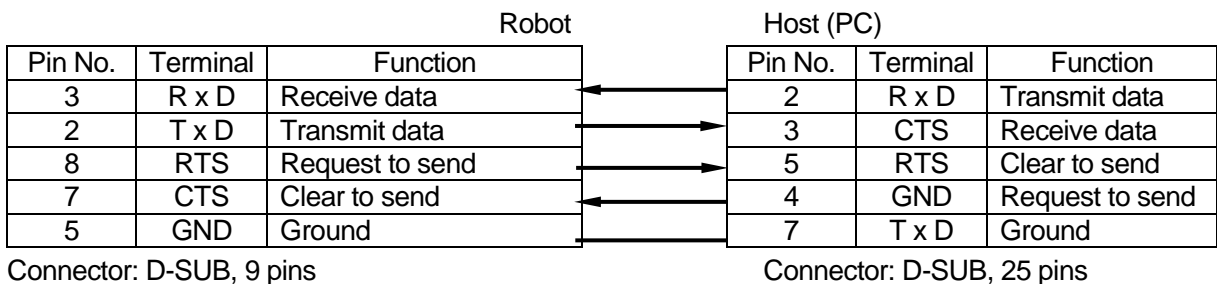

Use cables which are suitable for each PC you are using.

Normally a D-SUB, 9 pin is connected to the serial port mark "COM1" on the back of the PC.

■ COM Settings

To get the robot and PC into a transmittable state, select the COM port on the PC side, and make sure that the parameters for both the robot side and PC side match.

(You can't confirm or set the communication parameters on the robot side from the PC).

For further information refer to the next page and install and startup JR C-Points Limited Edition (included on the operation manual CD)

PC

PC [Robot] → [COM Status]

Startup JR C-Points Limited Edition and after selecting [Robot] from the menu bar, select [Port Settings] from the pull down menu.

Confirmation and settings made here are settings on the PC side.

The "Port" setting is the COM port number on the PC side used to connect to the robot. Select the COM port number on the PC side.

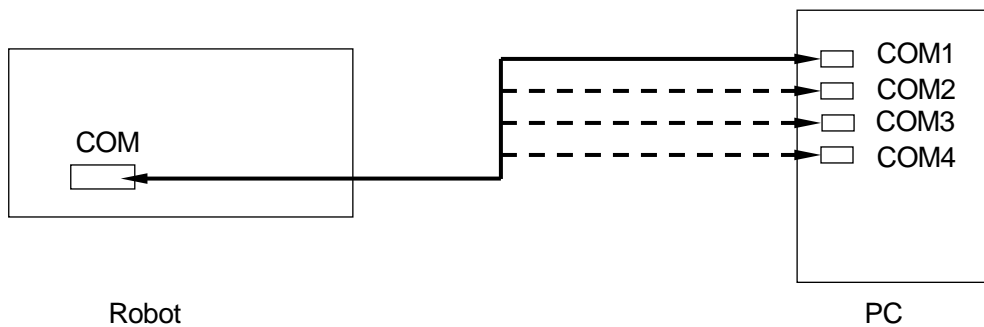

Robot

TP [Administration]
[Administration Settings Mode]
[COM Setting]
[COM 1 Communication Setting]

Push the MODE key and switch to Administration. Follow the procedure above and select [COM 1 Communication Setting]. Confirm/set each communication parameter so they match up with the settings on the PC side.

In the JR C-Points Limited Edition menu bar select [Robot] and then from the pull down menu bar click [System Information]. If the information is displayed, the connection is complete.

NOTE

JR C-Points PC software (optional) cannot do this same operation.

■ JR C-Points Limited Edition requirements

To operate JR C-Points Limited Edition (included in the operation manual CD), the following are necessary:

Computer	A PC capable of running Windows® 2000/XP
Memory capacity	32MB or more
OS	Microsoft Windows®2000/XP
Hard disk capacity	20 MB or more free disk space after installing Windows® 2000/XP
COM Port (serial port)	One free COM port for connecting the robot Connect the COM 1 port on the robot side to the PC COM port using an RS-232C straight cable.

The required memory capacity and hard disk capacity can vary depending on the PC's system requirements.

Also, be careful when using the PC because if there is not enough free hard disk space, it can result in insufficient memory during operation or other such problems.

■ How to install JR C-Points Limited Edition (included on the operation manual CD).

1. Startup Windows® and confirm it is operating properly. Also, close down any other open applications.
2. Insert the operation manual CD into the CD-ROM drive. In the [JCP*E***L] folder (* = specifications, *** = version number) double click [¥SETUP.EXE]. The installer will startup.
3. Follow the instructions on the screen and proceed with the installation.

NOTE

If the installer is started up when the software is already installed, it will begin the uninstallation process. To uninstall JR C-Points Limited Edition follow the same procedure as above to startup the uninstaller.

3. BACKING UP INDIVIDUAL CONFIGURATION INFORMATION

Every robot has individual configuration information.

This information may be necessary when replacing printed circuit boards if they become damaged. Be sure to create a backup file in case of contingencies.

Attention

The individual configuration information of the robot may be necessary when replacing printed circuit boards. Be sure to create a backup file before you use the robot.

■ Preparation

Turn OFF the robot and remove the panel cover on the side of the main unit and slide the special mode switch to ON. After checking that the robot is properly connected to the PC, turn ON the robot and the PC and copy "PSKBKUPE.EXE" from the operation manual CD-ROM to the local disk.

1. Start "PSKBKUPE.EXE" on the local disk. The dialog box to the right will appear.

2. Select the communication port of your PC which is connected to the robot and then click [OK].

3. Click [Download] and enter the name of the configuration information. (It will be saved with the extension ".JPB".)

The configuration information is then loaded.

If you want to select another COM port, select [COM Status] from the [COM] pull-down menu.

4. After downloading, click [Close] to exit "PSKBKUPE.EXE".

Turn OFF the robot and slide the Special Mode switch to OFF, then reattach the panel cover to the side of the main unit.

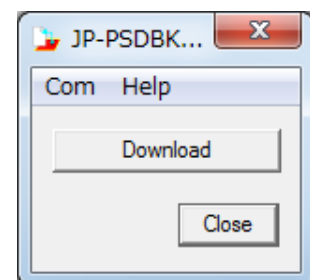
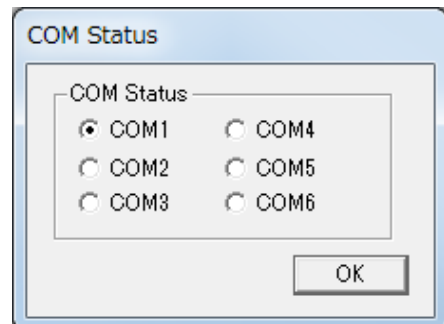

NOTE

Do not select [Upload Data] from the [COM] pull-down menu unless you are replacing the printed circuit boards.

4. BACKING UP C & T DATA

Always remember to back up data in case of contingencies.

To create backup data, startup JR C-Points Limited Edition on the PC and receive data from the robot, then save the received data as a file.

The data sent and received between the robot and the PC is teaching data and customizing data, sent as one unit (C & T data).

NOTE

To create backup data, the robot and PC must be connected. Refer to “2.6.4 Connecting to the PC” and make sure the robot and PC are able to interface.

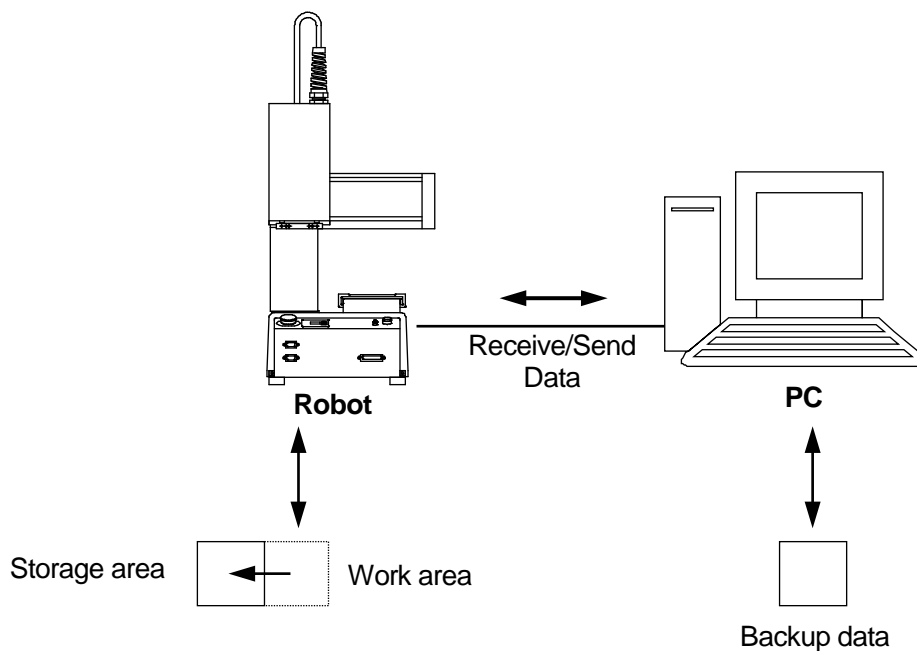

The robot has a data storage area and a work area. When you start the robot, the C & T data in the storage area is copied to the work area. The copied data is used to operate the robot, and teaching. The data in the work area is deleted when the power to the robot is turned OFF.

When receiving data from the robot, (the PC) receives work area data. After sending data from the PC to the robot, the sent data is automatically written to the storage area via the work area.

NOTE

If you are using JR C-Points software (optional), you can also back up the data by selecting [Receive C&T Data] from the [Robot] pull-down menu.

Have the robot do one of the following:

Switch Run Mode: Waiting for run start (Wait Start Point)

External Run Mode: Waiting for run start (Wait Start Point)

Teaching Mode: Point value setting screen

Startup JR C-Points Limited Edition, and from the [Robot] pull down menu select [Receive C & T Data].

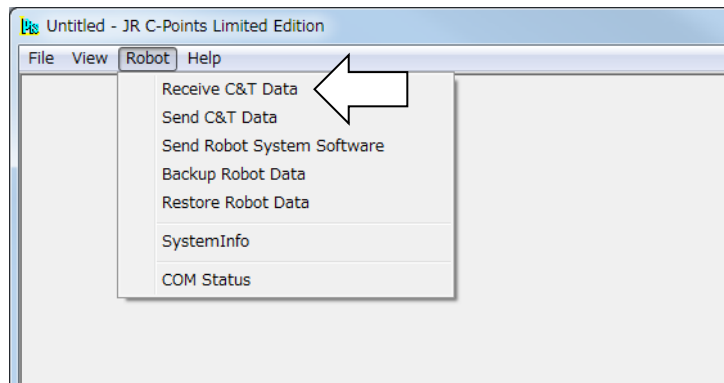

To create a backup file, click the [Receive] button. The C & T data transfer begins.

Once the transfer of C & T data is complete, [The C&T Data was Received Successfully] message appears on the screen.

Note that the C & T data is not displayed on the screen.

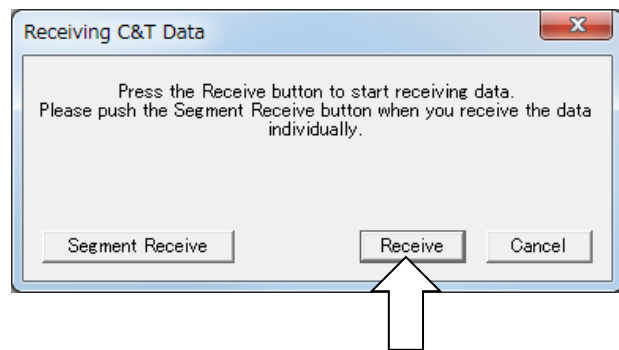

Save the file by selecting [Save as] from the [File] pull down menu.

If you send a backup file to the robot using [Send C&T data], the robot will revert back to the received data.

Click [Segment Receive] to select and receive a specific program or customizing data etc. For example, when the backup file is open, select just one program with [Segment Receive] and only that received program is updated.

With [Segment Receive], you can update the robot's C & T data for only a specific program, etc.

5. DOWNLOADING THE ROBOT SYSTEM SOFTWARE

This robot is controlled by built-in robot system software. To update the robot system software, follow the instructions below.

The robot system software is included on the operation manual CD-ROM under the following file names:

JRN_+++_****.jsy (“+++” varies according to specifications. “****” indicates the version number.)

1. Turn OFF the robot and remove the panel cover on the left side of the robot to slide the special mode switch to ON.
2. Turn ON the robot again, and startup JR C-Points Limited Edition on the PC.
3. In the menu bar select [Robot] and then click [Send Robot System Software] from the pull down menu. The dialog below will appear.

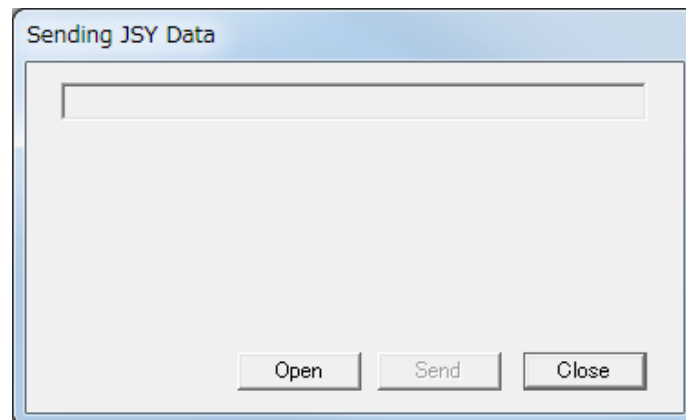

4. Click [Open], select the robot system software to download and click [Send].
5. After transmission, turn OFF the robot and slide the special mode switch back to OFF, then reattach the panel cover to the side of the robot.

NOTE

- To perform this operation, the robot and PC must be connected. Refer to “2.6.4 Connecting to a PC” and make sure the robot and PC can interface.
- If you are using JR C-Points software (optional), the robot system software can also be upgraded by selecting [Send Robot System Software] from the [Robot] pull-down menu. Additionally, JSYROADE (in the operational manual CD) can do this same operation.

6. SETTINGS NEEDED FOR TEACHING

Before beginning program teaching etc., make the following settings match up with the environment in which, and methods with which you will use the robot.

6.1 4-Axes: Tool Data

If the total weight the Y axis will carry exceeds 3kg, set the [Tool Weight] to 6kg.
(The tool weight for JR2200N is fixed at 3.5kg. This cannot be changed.)

NOTE

If the tool weight is heavier than the settings, it is possible a positioning error will occur.

For 4 axis specification models, always set the tool data (TCP-X, Y) before doing program teaching. If you do program teaching without first setting the tool data, all of the registered coordinates will need to be revised when exchanging tools.

NOTE

For 3-axis specification models, when changing tools refer to "Settings for Replacing Tools" in the operation manual *Maintenance*, and input the differences between the tools you are installing and the tools used in program teaching.

The following settings are in [Tool Data]:

- Tool Weight
- TCP-X: X-direction distance from the standard tool position (R-axis center) to the tool center point
- TCP-Y: Y-direction distance from the standard tool position (R-axis center) to the tool center point
- TCP-ΔZ: Z-direction distance from the registered tool center point to the current tool center point

TP MENU [Program Data Settings]
[Tool Data]

PC [Program] → [Program Data] → [Tool Data]

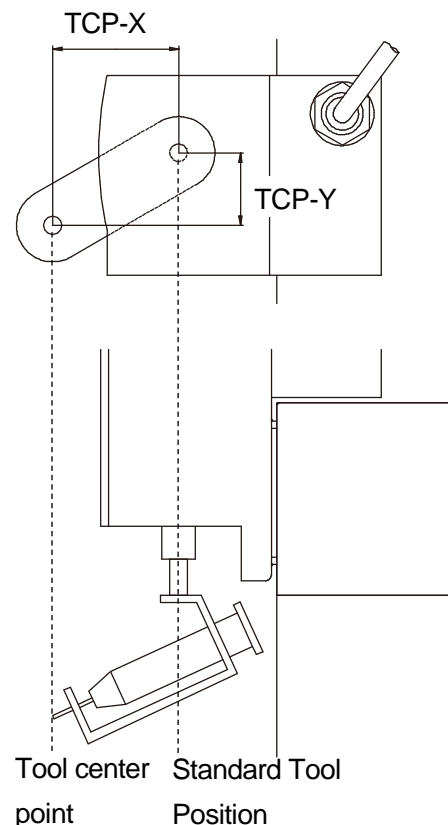

6.2 Work Weight

NOTE

There is no [Work Weight] entry for the JR220N. This is fixed at 7kg.

If the total weight the X table will carry exceeds 8kg, set the [Work Weight] to 11kg.

NOTE

If the work weight is heavier than the settings, it is possible a positioning error will occur.

TP  MENU [Program Data Settings]
[Work Weight]

PC  [Program] → [Program Data] → [Work Weight]

7. SETTINGS NEEDED TO MAKE A RUN

Before running a point or program, make the following settings match up with the environment in which, and the methods with which you will be using the robot.

7.1 External Run Mode Settings

If using the robot in the External Run Mode, set the source from where the registered start signal becomes valid.

The start signal can only be made valid in one place. If sending the start signal from I/O-SYS, a run start from COM 1 (PC) is not recognized. If you want to direct a run start from the PC, set to COM 1.

TP MODE [Administration]
[Administration Settings Mode]
[Start Channel]

PC [Robot] → [Administration Settings]

- I/O-SYS.....Turn ON #sysIn1 (I/O-SYS) and the run starts.
- COM1Send a run start command from the PC and the run starts.
For command details, refer to the operation manual *External Control II*.
- User DefinitionSet to [User Definition] and a run start cannot be made from either I/O-SYS or COM1.
You can expect to use this setting when executing a program or arm movement for a user registered Run Mode operation. For example, when starting a run by the [callProg] command for a job when the power is turned ON, or a job that runs after mechanical initialization, set it to User Definition.
In this situation, it becomes the user's responsibility to make sure there is only one startup source. Set to [User Definition] and [callProg] and drive commands are recognized in Run Mode operations.

7.2 Setting Program Numbers

Here you can set the method for changing program numbers.

7.2.1 Changing Program Numbers

To change program numbers, there are the four methods as shown below. These methods can be restricted.

- The teaching pendant key.
- The program selection key (operation switch) on the front of the robot
- A signal input via COM1
- A signal input via I/O-SYS

For example, if you set COM1 to [Valid] and the others to [Invalid], changing program numbers is only possible through the PC, and you can no longer change program numbers from the teaching pendant or the selection keys on the front of the robot, etc.

TP [Administration]
[Administration Settings Mode]
[Changing Program Number]

PC [Robot] → [Administration Settings]

7.2.2 Program Number Reading Code

You can select whether the signal, that match I/O signal program numbers 1 – 128 are read as [Binary] or [BCD]. If using [BCD], program numbers 1 – 8 are assigned in the one's place, and numbers 16 – 128 are assigned in the ten's place.

NOTE

If specifying from I/O-SYS when 127 or more [Binary], or 79 or more [BCD] program numbers are set, the “Last Work” signal function needs to switch to “Program Number 7” (assigned to I/O-SYS function).

TP [Run Mode Parameter]
[I/O Settings]
[Program Number Reading Code]

PC [Data] → [Run Mode Parameter]

7.2.3 Program Number Changing Method

Connect a digit switch to the I/O terminal, and then if you want to change program numbers, you need to set [Loading at Start].

Settings	Content
LOAD/ACK Handshake	When the "Program Number Load" signal comes ON, I/O signal program numbers 1 – 128 are captured, "Program Number ACK signal" is output, and the program number changes.
Loading at Start	When the start instruction is received by the robot, the statuses of I/O signal program numbers 1 – 128 are captured, and the program number changes.

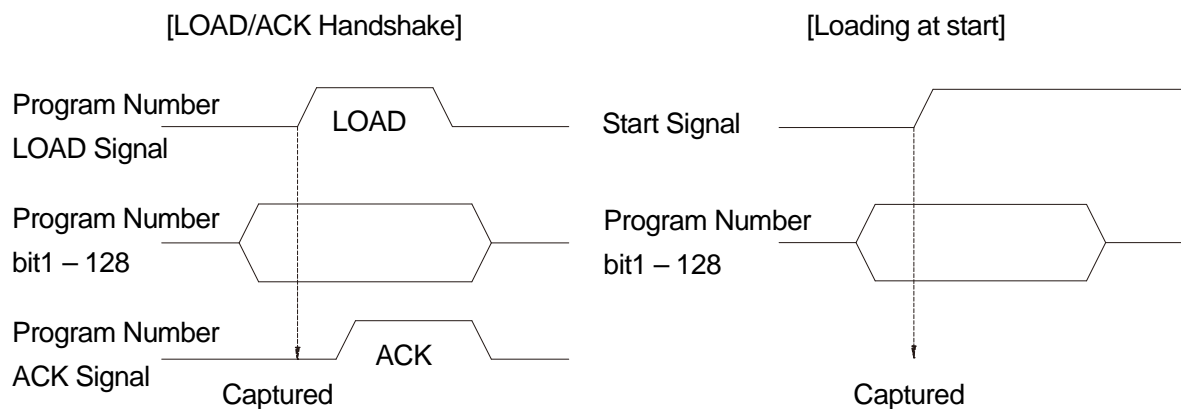

NOTE

The default settings capture signals "Program Numbers 1 – 64".

If you want to use the signal "Program Bit Number 128", you must switch over the signal function (I/O-SYS Function Assignment).

TP MENU [Run Mode Parameter]
 [I/O Settings]
 [Program Number Changing Way]

PC [Data] → [Run Mode Parameter]

7.3 I/O-S Settings (CE specification models only)

The I/O-S is a connector intended for use with an area sensor or a light curtain etc. If the signal from this connector goes ON during a run, the robot performs an emergency stop.

It is possible to restrict the emergency stop so it will not occur when the robot is in standby when the I/O-S signal goes ON.

Robot Status	I/O-S Function Settings	Action When the Signal from I/O-S goes ON
Running	Emergency Stop	Emergency stop occurs
	Interlock	Emergency stop occurs
Standby	Emergency Stop	Emergency stop occurs
	Interlock	Emergency stop doesn't occur

TP  [Run Mode Parameter]
[I/O Settings]
[I/O-S Function Settings]

PC [Robot] → [Run Mode Parameter]

8. HOW TO CONVERT THE DATA FROM JR2000 INTO JR2000N

To use JR2000 teaching data as JR2000N C&T data, broadly speaking it is necessary to convert the data following the three steps below.

1. Load the data from the JR2000 to the PC using JR-Points software (JR2000 optional).
2. Open the received data from 1 above using JR C-Points Limited Edition.
3. Send the data from the PC to the JR2000N using JR C-Points Limited Edition.

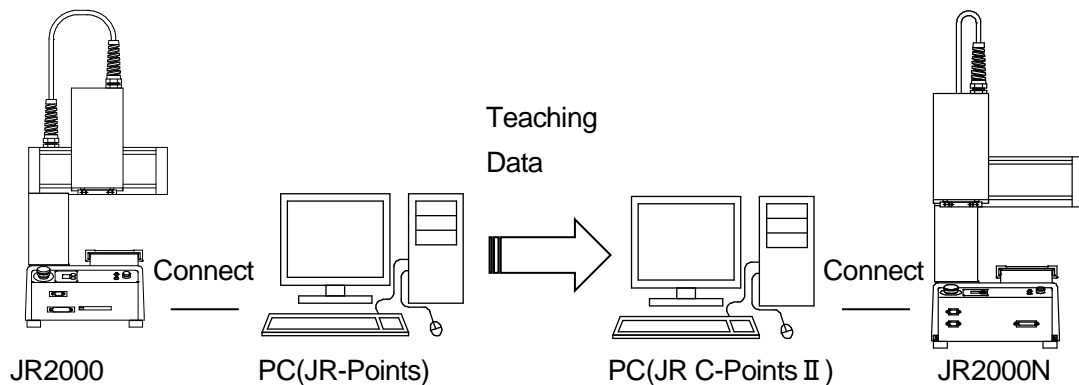

To perform this operation, the robots must be connected to a PC. Refer to “2.6.4 Connecting to a PC”, and make sure they can interface.

In addition to JR C-Points Limited Edition, JR C-Points (optional) can also be used to convert data.

You can connect both the JR2000 Series and the JR2000N Series robots to one PC. Or you can also connect a PC to the JR2000 Series robot to receive data, then disconnect the JR2000 and connect the JR2000N Series robot to the PC to send data.

(To convert data using a PC, both JR-Points and JR C-Points Limited Edition must be installed on the PC.)



Caution

Make sure that the power to both the robot and the PC are OFF before attaching or removing cables. Failure to do so can result in malfunction or data loss.

The following describes how to convert teaching data:

(The PC with JR-Points and JR C-Points installed is connected to the JR2000 Series and JR2000N Series robots.)

1. Turn ON the robot and the PC. If the robot is already ON, turn it OFF and then turn it ON again
2. Start JR-Points on the PC and set the port status to the COM port connected to the JR2000 Series robot.

PC [Robot] → [COM Status]

3. Transfer the teaching data from the JR2000 Series robot.

PC [Robot] → [Receive Data]

4. After transmission, the retrieved data will be opened in JR-Points. Name the data and save it. The file extension is “.rps”.

PC [File] → [Save As]

5. Exit JR-Points and start up JR C-Points.

6. Set the port status to the COM port connected to the JR2000N Series robot.

PC [Robot] → [COM Status]

7. Select [Open] from the [File] pull-down menu and change [File Type] in the [Open] dialog box to [JR Points File (*.rps)] and open the data file from the JR2000 Series robot.

PC [File] → [Open]

8. Transfer the data to the JR2000N Series robot. Note that when data is transferred from the PC to the robot, any data stored in the robot is deleted.

PC [Robot] → [Send Data]

NOTE

For information regarding JR C-Points Limited Edition installation etc., refer to “2.6.4 Connecting to a PC”.

MEMO

Janome Sewing Machine Co., Ltd.
Industrial Equipment Sales Division

1463 Hazama-machi, Hachioji-shi, Tokyo 193-0941, Japan

Tel: +81-42-661-6301

Fax: +81-42-661-6302

E-mail: j-industry@gm.janome.co.jp

Machine specifications may be modified without prior notice to improve quality.

No part of this manual may be reproduced in any form, including photocopying, reprinting, or translation into another language, without the prior written consent of JANOME.

©2008 – 2017, Janome Sewing Machine Co., Ltd., All rights reserved.

963807111 as of 2017-01

Japanese Ver. 2017-01