

SiD Muon System

LOI Plans/Status

KPiX-RPC R&D

SiPM Generic R&D Status

G. Fisk, C. Milstene, A. Para, P. Rubinov - Fermilab

D. Wright - Livermore Nat'l Lab

R. Van Kooten - Indiana U.

G. Blazey, A. Dychkant, V. Zutshi - No. Ill. U.

B. Baumbaugh, M. McKenna, M. Wayne - Notre Dame

S. Manly - U. Rochester

A. Driutti, D. Cauz, G. Pauletta - U. Udine/INFN Trieste

S. Gollapini, K. Gunthoti, P. Karchin, A. Gutierrez - Wayne St

H. Band - U Wisconsin

LOI Schedule - SiD Muon System

- ✓ November 15, 2006 - Draft report for sub-system with discussion of issues. (Revise DOD: 5 pages)
- ✓ LCWS08: Nov. 16 - 20.
Physics benchmarking:
Muon ID efficiency and purity studies done for single μ 's and μ 's from b-pairs. Also N. Graf studies of HZ associated prod'n done for barrel; forward HZ studies planned; forward muon software not yet thoroughly tested.
- December 15, 2008: Muon sys. benchmarking chapter studies almost adequate.
- ✓ January 15, 2009: Muon system LOI draft available.
- ✓ February 15, 2009: Muon system Final draft.
- ✓ March 31, 2009: LOI to Research Directtore

IDAG Questions

- SiD Muon system sensitivity to machine backgrounds as characterized by the MDI panel.
- Calibration and Alignment.
- Engineering status of subsystem support structures and dead zones.
- Plans for obtaining the necessary R&D to get from design concept to robust detector proposal.
- Push-pull impact on assembly areas, detector transport, detector services, detector maintenance and efficient operation.
- Subsystem performance issues at higher CM energies.
- Explain how the subsystem design was optimized.

IDAG Q1: Sensitivity of SiD muon detector to machine backgrounds as characterized by the MDI panel

RPCs

Scintillator + SiPMs

Both RPCs and scintillator strips with SiPM readout can be used to measure beamline muons. Incoming background muons are out of time by $< 50\text{ns}$ with outgoing muons generated in collisions at the IP. Typically many foils or strips will be hit in both the barrel and forward detectors.

IDAG Q2: Calibration and Alignment Schemes

RPCs

Calibrate with background or beam induced muons.

Assemble a group of RPC modules in a frame so they are accurately located relative to each other. Install with survey targets visible outside the frame for optical survey.

Scintillator + SiPMs

Calibrate with 10 – 20 ns LED generated light pulses. SiPMs give 1, 2, 3, 4, 5, .. photo-electrons.

Assemble 3 X 5 m² planes of 4 cm wide strips accurately located with fixturing on an Al skin and channel frame with alignment holes to transfer strip locations to survey target.

IDAG Q3: Support structure engineering model and dead zones in simulation.

For both the RPC and scintillator muon detectors the solenoid flux return Fe is the support structure. Detector modules will be installed in Fe gaps. Electrical services, front-end electronics, cable sizes and routes for cables are anticipated but are not yet on engineering drawings, but will be added in the next several months. Dead zone areas and volumes are generally calculated. For both RPC and scintillator systems beam exposure of modules will be used to confirm calculated detector efficiencies.

IDAG Q4: Plans for necessary R&D

Strip-scintillator and SiPMs:

- R&D on both Hamamatsu and IRST SiPMs is underway. Both companies have delivered ~100 devices to our R&D group. Test results from both companies are good.
- Testing devices with scintillator strips has started. We plan to build some full-size strip detectors this coming year ~4 m long and beam test them in the Fermilab MTest beam.
- In addition to beam calibration we plan to develop calibration of fibers in strips with an illuminated-by-LED-pulses clear fiber to to the in-situ WLS fibers - a la a KEK Shinshu U. invention.
- Measurement of edge and end of strip efficiencies and signal attenuation along the length of strips is planned.
- Collector/digitizing electronics will use Minerva boards.
- Later we will design and test the routing of cables and collection of strip output pulses in multi-conductor miniature coax.
- Co-extrusion of scintillator around WLS fiber using the Lab 5 extruder is in the future. Improved WLS fiber light collection is the goal.

IDAG Q4: Plans for necessary R&D

RPCs:

- R&D ongoing to establish KPIX or KPIX variant as a low cost readout option.
 - Proof of principal.
 - Optimize parameters.
- Characterization and aging studies of IHEP RPCs.
 - 10 IHEP RPCs at SLAC
 - Tests with avalanche gases planned
 - Aging studies with HF

IDAG Q5: Push-pull ability w/rt assembly areas needed, detector transport and connections and operating performance for stable and time-efficient operation.

The muon detectors, for the most part are located in the Fe gaps for solenoid flux return. So, they are protected during the movement of the detector. Electrical services will be supplied to the detectors and their respective electronics via cables that are safely rated to handle the required current and voltage, less than 100A at 75V or less, except for the RPC HV which will be less than 10kV.

For efficient operation of the detector a monitoring and control system will be in operation to constantly monitor voltage and current to verify that safe operating conditions are met, and to warn technical personnel if devices go out of tolerance.

IDAG Q6: Muon Sys. Performance @Higher Collider Energies

- The precision of p_μ , $\Delta p_\mu / p_\mu$ is determined by the Si tracking system, which reaches a minimum at high momentum due to spatial resolution and reduced multiple scattering.
- For muon identification, track matching of candidates found in the Fe should improve slightly because of reduced multiple scattering. The minimum (σ_x, σ_y) , neglecting multiple scattering, is $w/\sqrt{12}$ for a single strip. The mean track position can be improved only by using more muon detector planes (no m.s.). \checkmark
- At higher E_{cm} , as we heard from Mat Charles, jet energy resolution deteriorates due to energy that leaks out of the calorimeters. The jet resolution can be improved by using jet energy that leaks into the muon system: i.e. the "tail catcher".
- All of the above needs to be quantified.

IDAG Q7: How was the muon system optimized?

- Cost
- Performance

Preliminary RPC/KPIX Data

Henry Band
U. Of Wisconsin

Ryan Herbst,
Dieter Freytag
SLAC

- “Proof of Concept”
- RPC interface board
64 channels
- First tests -AC
coupling
 1. Optimize
resistor/capacitors
values
 2. Protection circuits
 3. KPIX readout modes

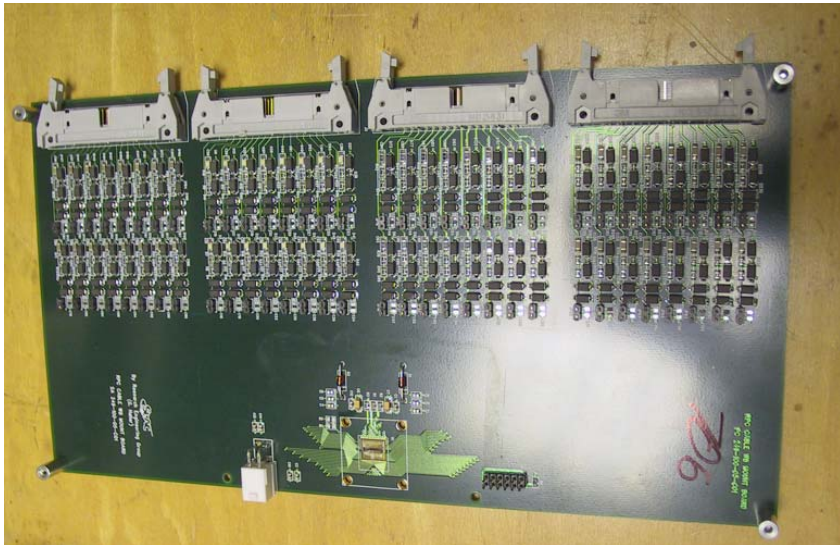

Setup



HV Gnd
1 M Ω

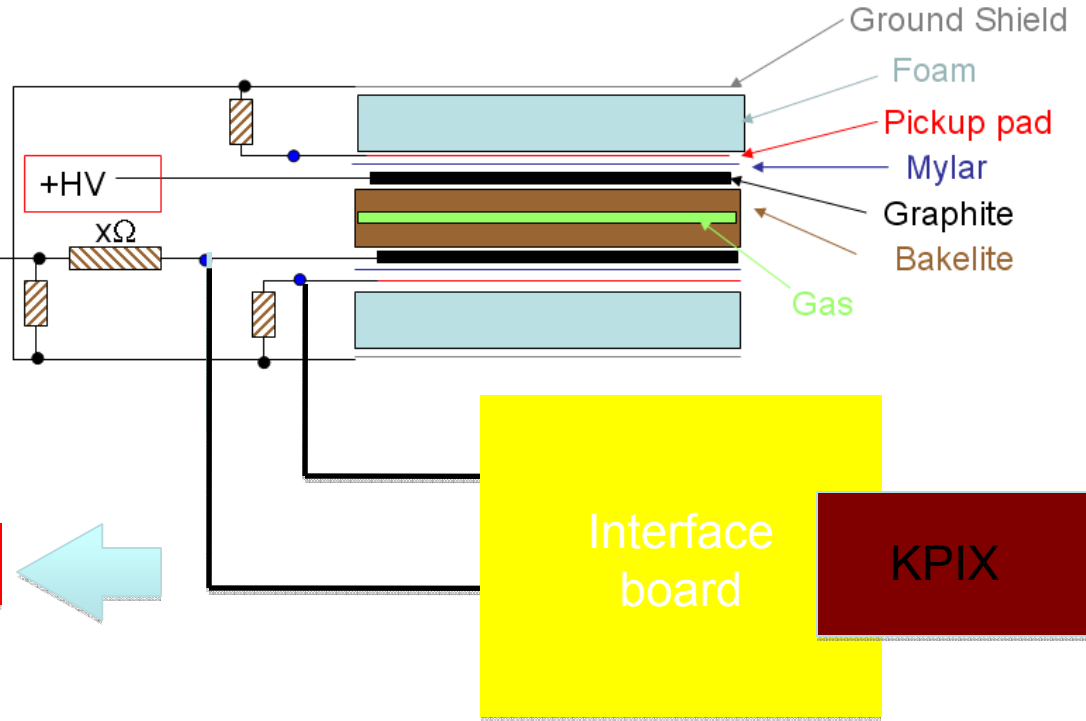

RPCs -
IHEP 0.5 by 0.5 m (4 + 6)
Italian Bakelite 0.5 by 0.5 m
12 Strips ~4 cm by 50 cm
C ~ .3 nF

Gases
BaBar avalanche gas – 75.5%
Freon 134a, 19.4% Argon, 4.5%
isobutane, 0.6% CF6
Ordered CERN/ANL
94.5% Freon 134a, 5.0%
isobutane, 0.5% CF6

- Strip Termination 5-100 k Ω
- Blocking Capacitor 0.1 – 5 nF
- KPIX int. time 1.4 – 4 ms
- Asynch. or triggered readout
- Periodic or DC resets

Steps along the way

Normal gain saturates - use low gain
 Strip multiplicity high – make blocking cap. large
 KPIX inputs unstable – power chip earlier, reduce RC time, reduce R

Pedestal wider than expected
 Isolate HV

Normal gain vs low gain

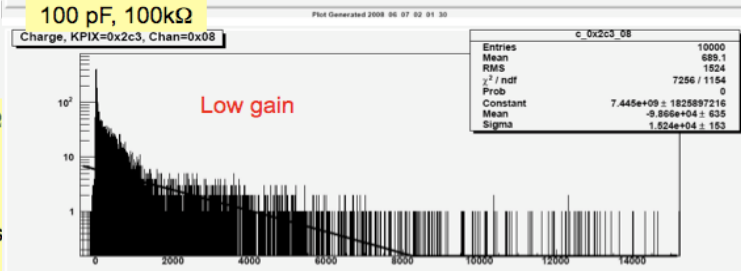
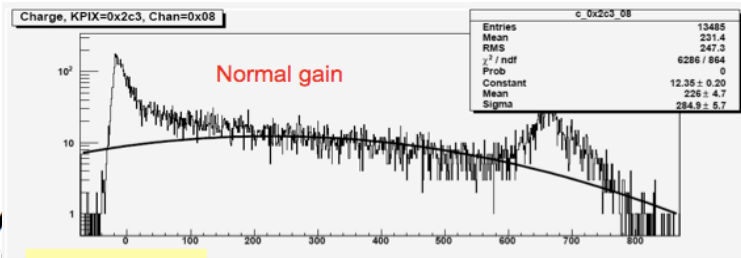

100 pF, 100kΩ
 Int time ~ 4
 microsec
 KPIC channels
 0 -15

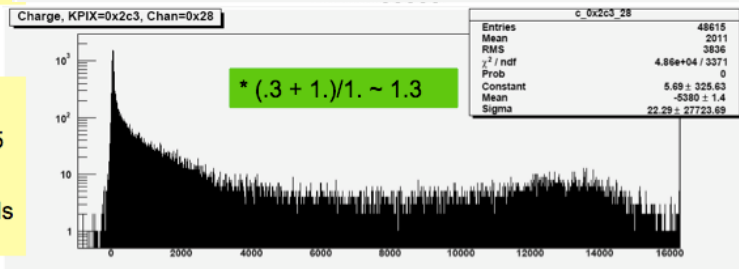

1 nF, 10kΩ
 Int time ~ 1.5
 microsec
 KPIC channels
 32-47

fC ->

Noise Reduction
 Add 1 MΩ to HV
 leads

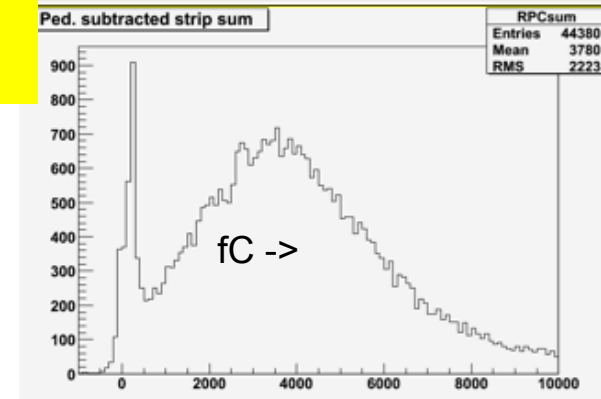
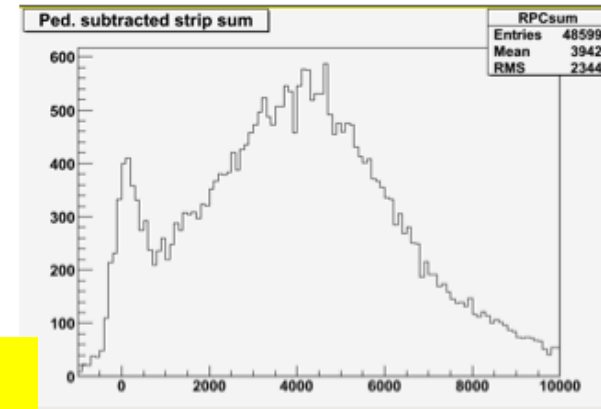

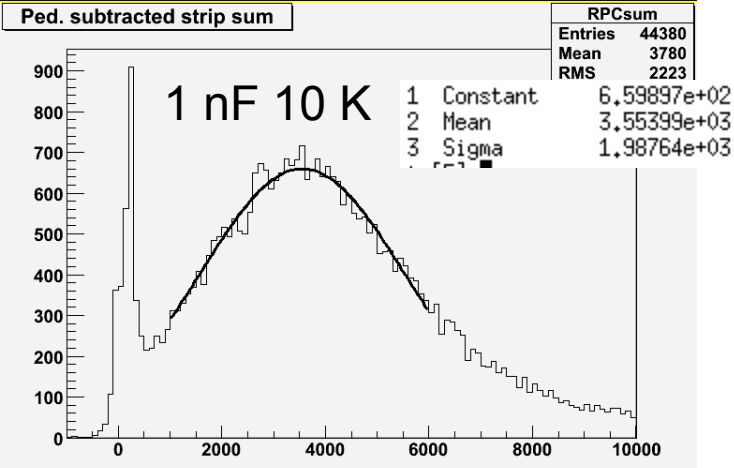

9350 V

Compare transition board components
~20% variation

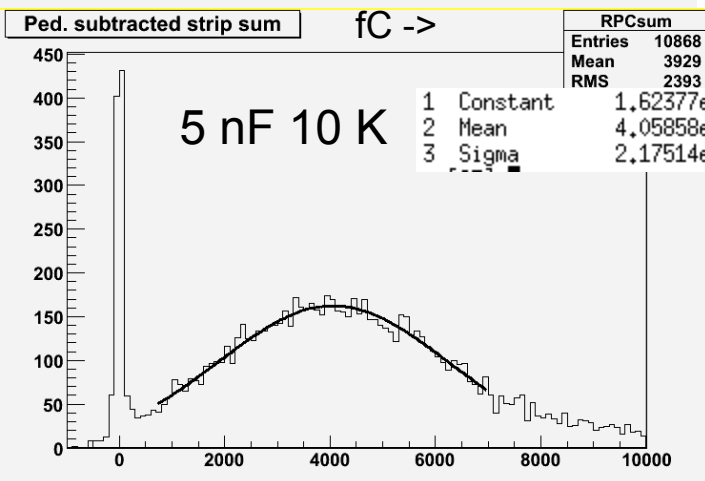

RPC probably poorly aligned resulting in more events without signal

Total charge 3-4 pC, larger, as expected, than ANL RPCs. Need absolute calibration.

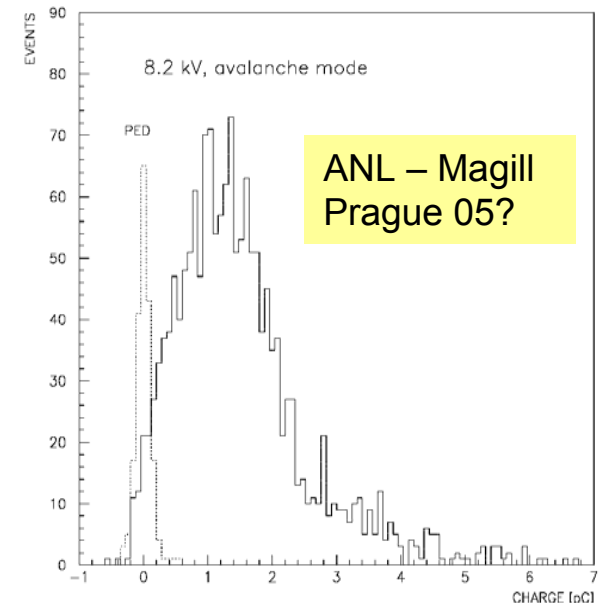
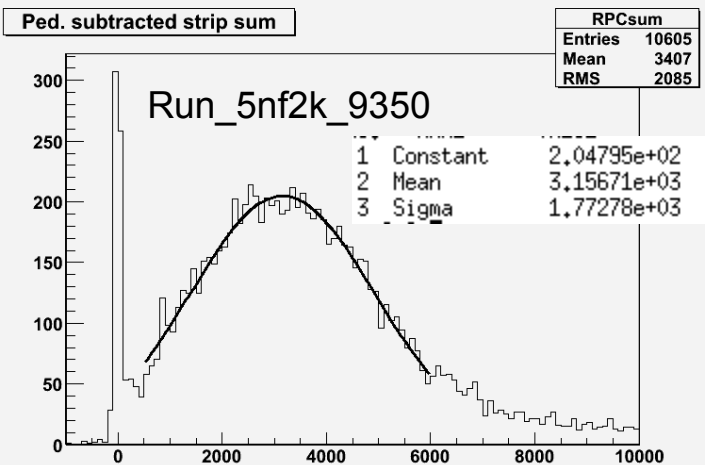

HV Scan

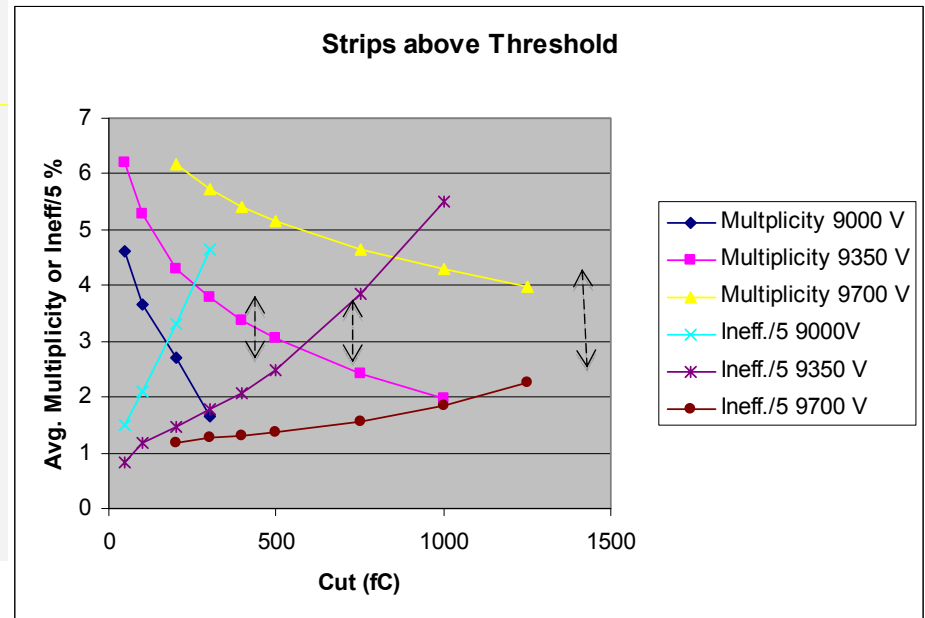
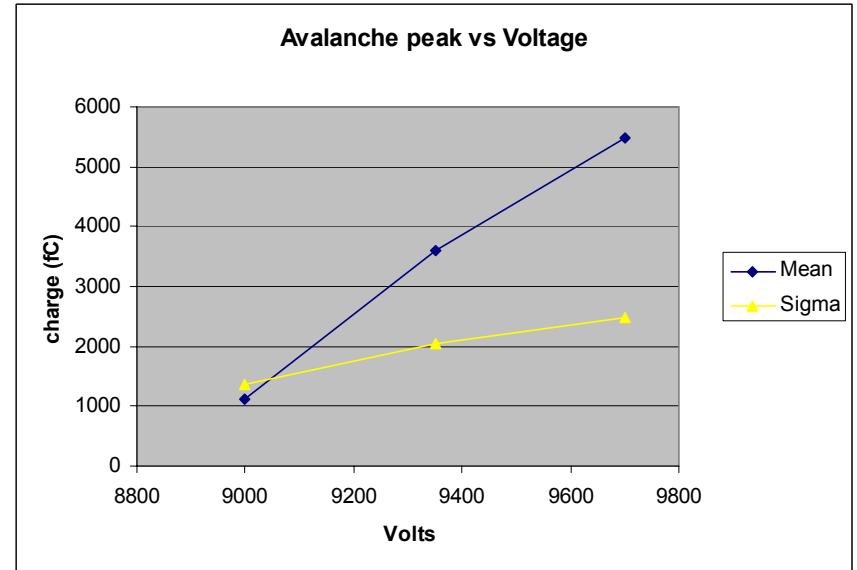
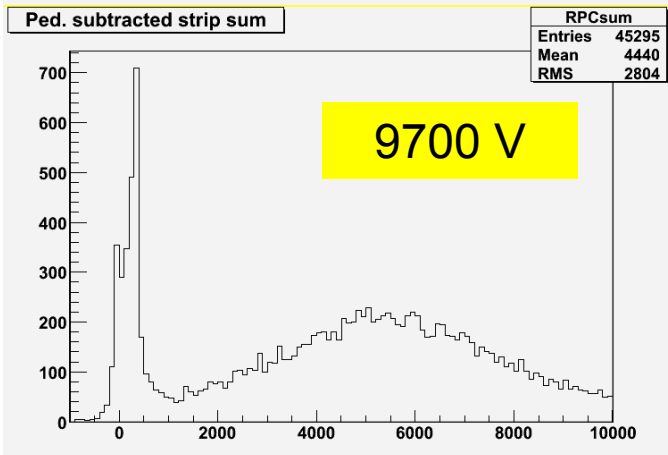
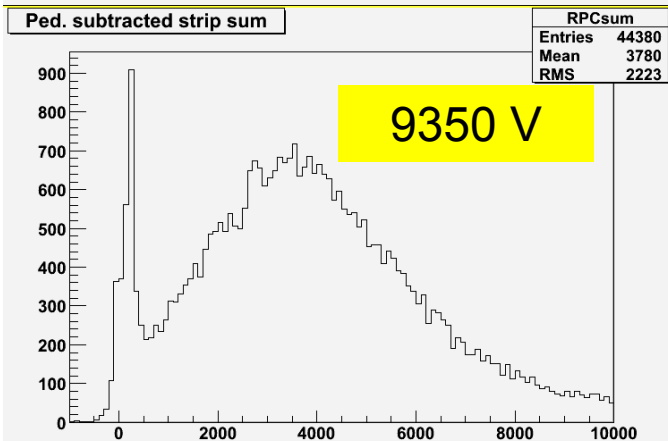
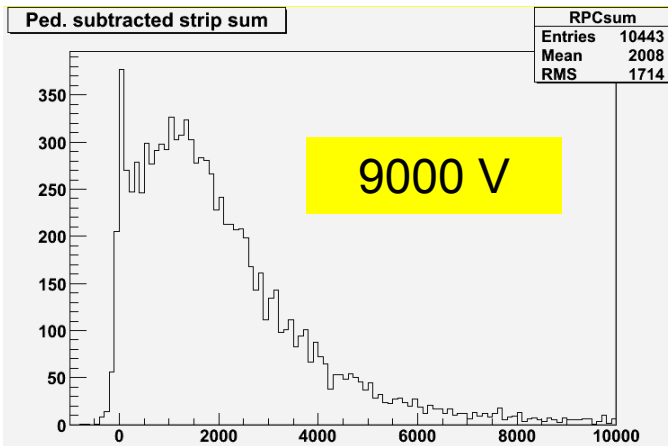

Charge Sum of all strips vs Charge of Max. strip vs Charge Sum of strips above cut

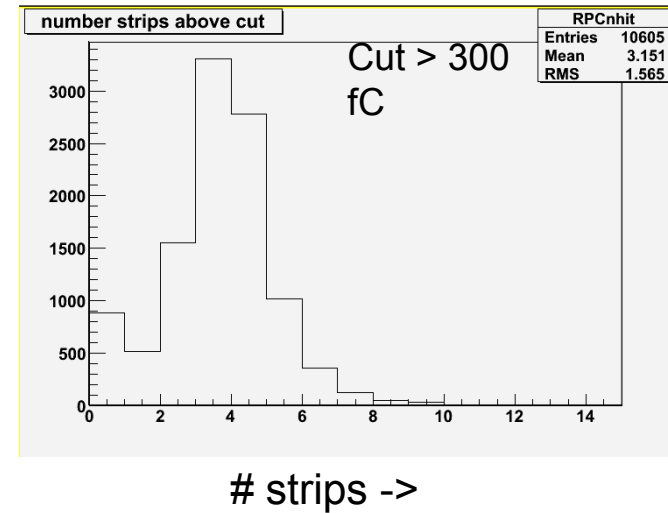
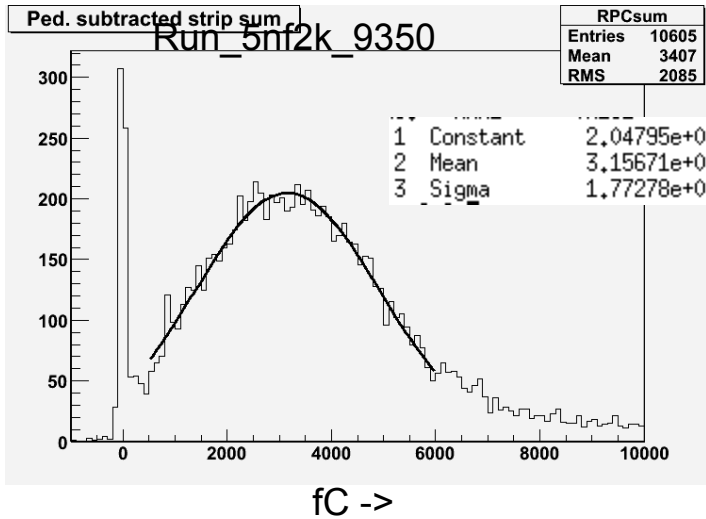

Less than half of the charge is in the max. strip

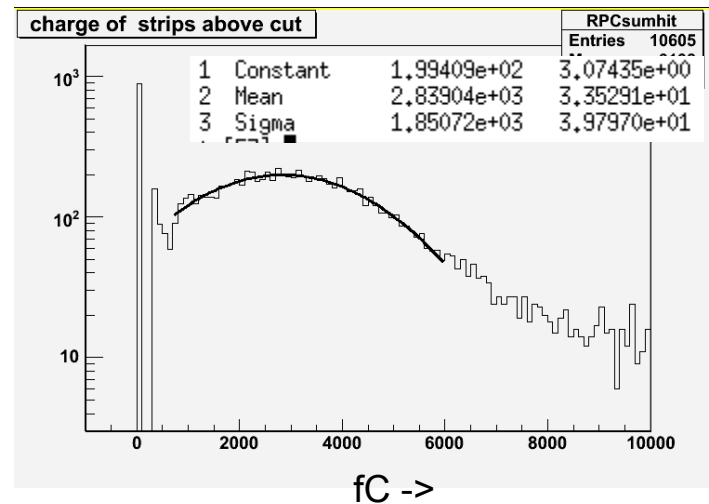
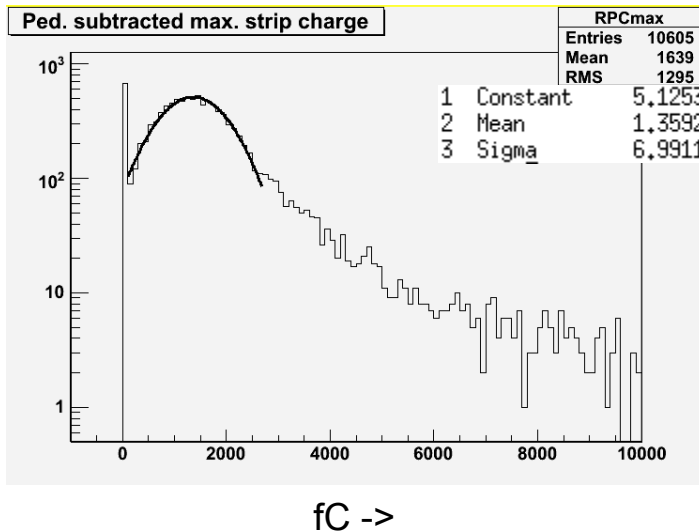

Plans

- Start of a long program
- Still disentangling RPC/KPIX effects
- Next steps
 - Understand strip multiplicity
 - Develop code to readout all 64 channels
 - Read out multiple RPCs
 - Readout opposite polarity
- Longer Term
 - Tracking, position resolution studies
 - Test IHEP RPCs
 - Test CERN gas
 - Test GEM pad readout Bakelite RPC
 - Pad readout of glass RPC

Hamamatsu MPPC 100 pixels $100\mu \times 100\mu$

Paul Rubinov

5mv/pe at nominal
bias voltage for
a 100 pixel device

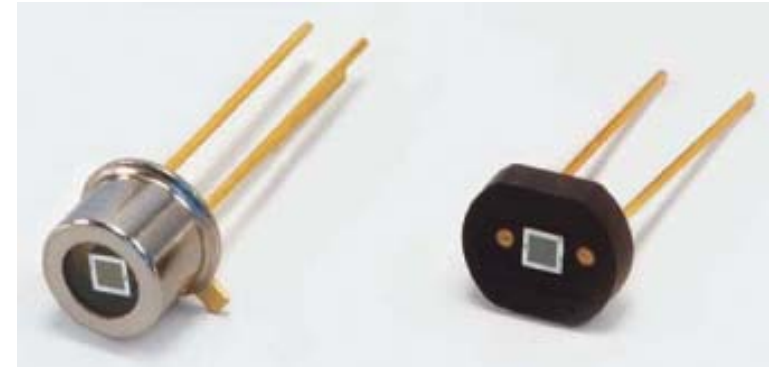

HV=70.0, LED on, 66ns gate

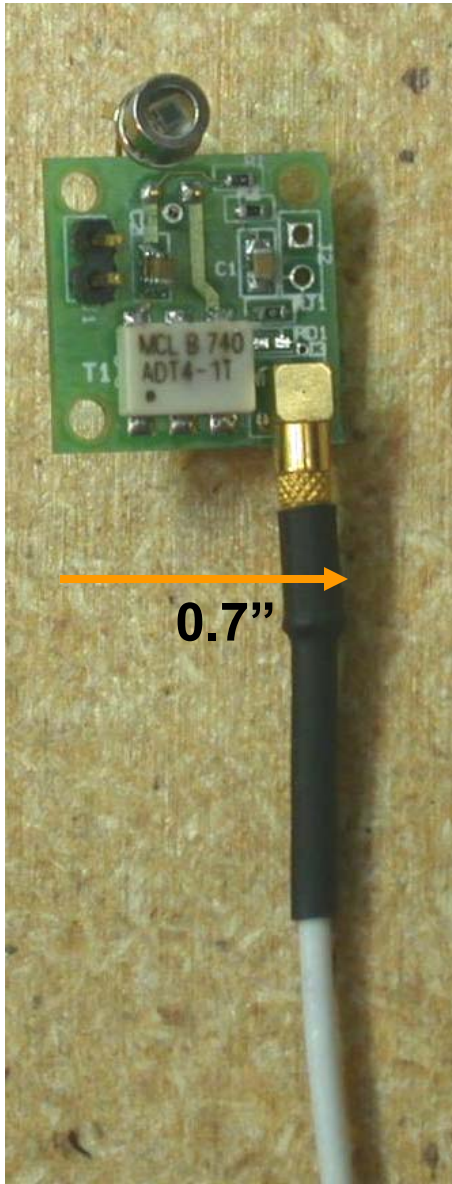
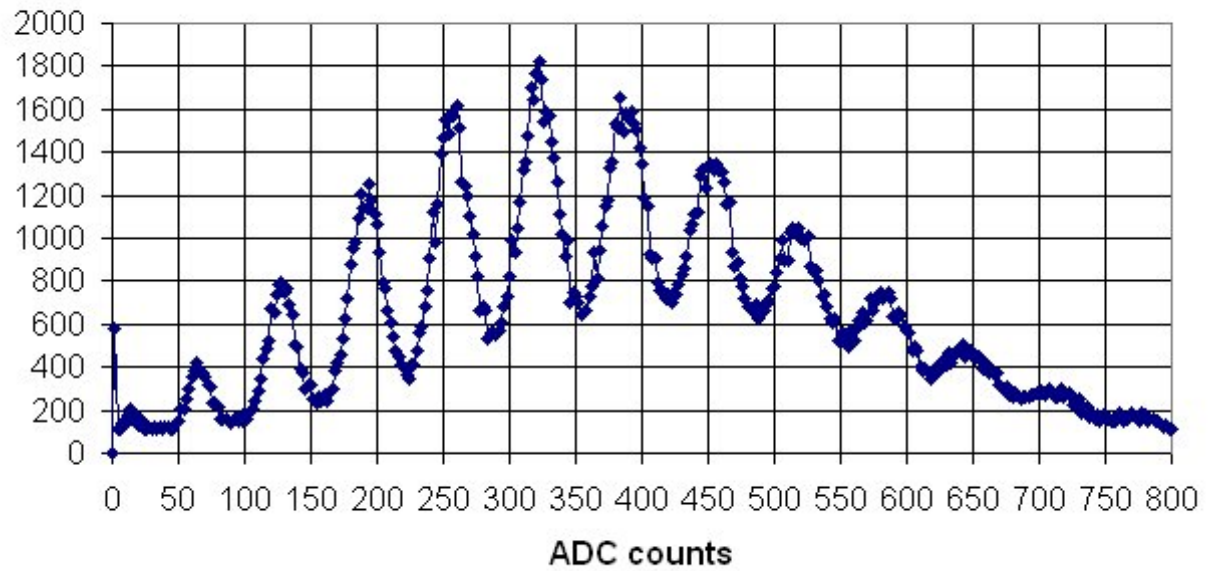

Strip-scint/Si-APD Tests at Notre Dame

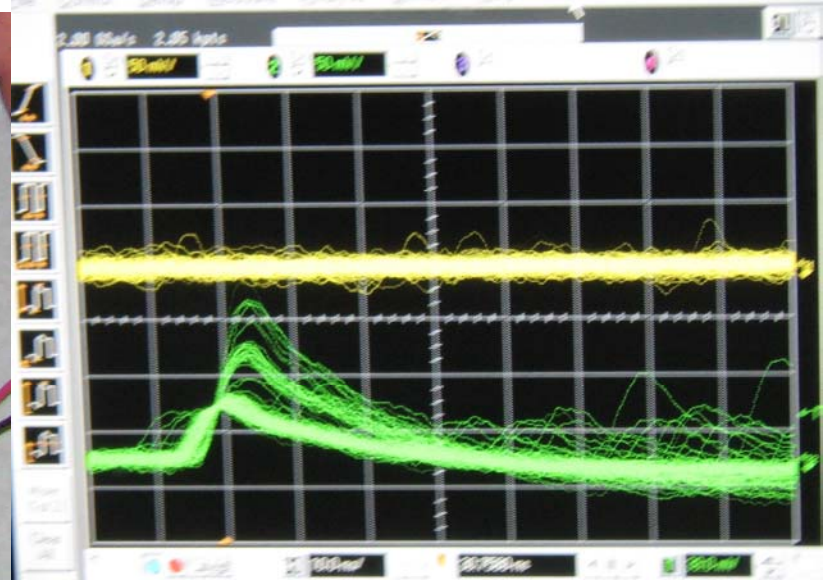
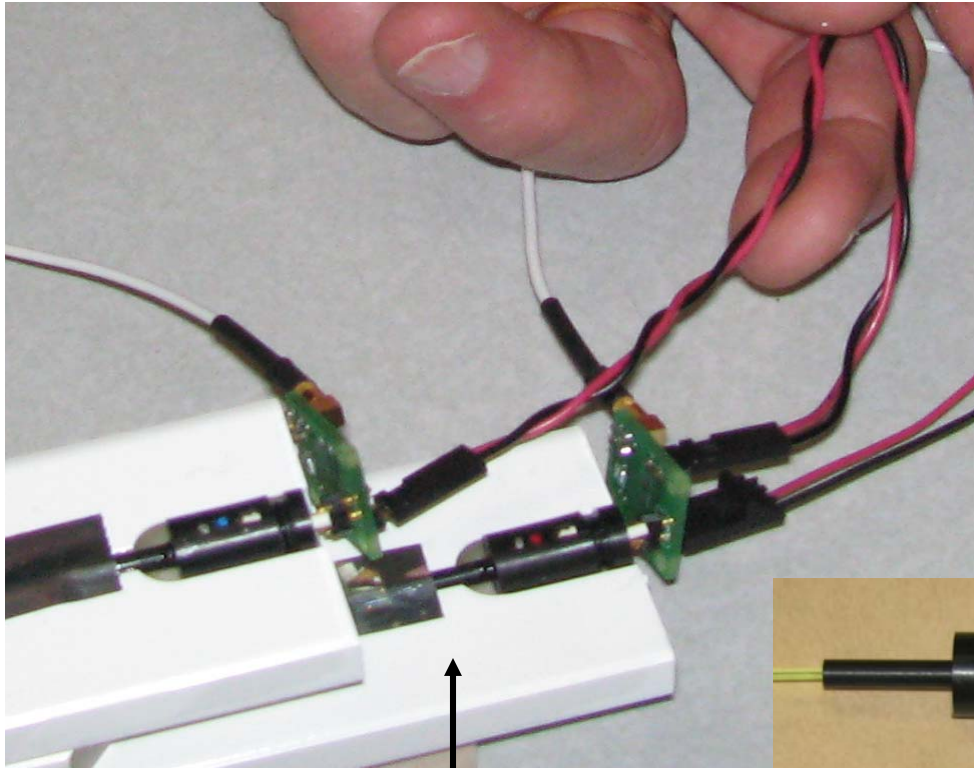

Two strips w/ WLS fiber, HPK MPPC, plastic holder assembly + front-end card & connectors

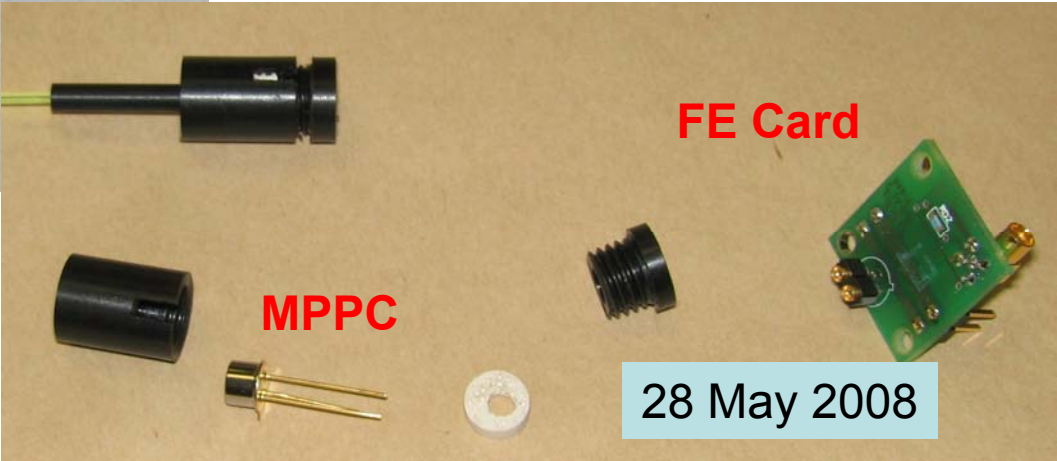

28 May 2008

Setup for Testing MPPCs with Scintillator Strips – Paul Rubinov

- Two scintillator strips with WLS fiber 1.2mm
- Single paddle with PMT placed above

- **Trigger**

paddle + one strip

- No momentum filter
- Wide angle acceptance
- Not 100% efficient

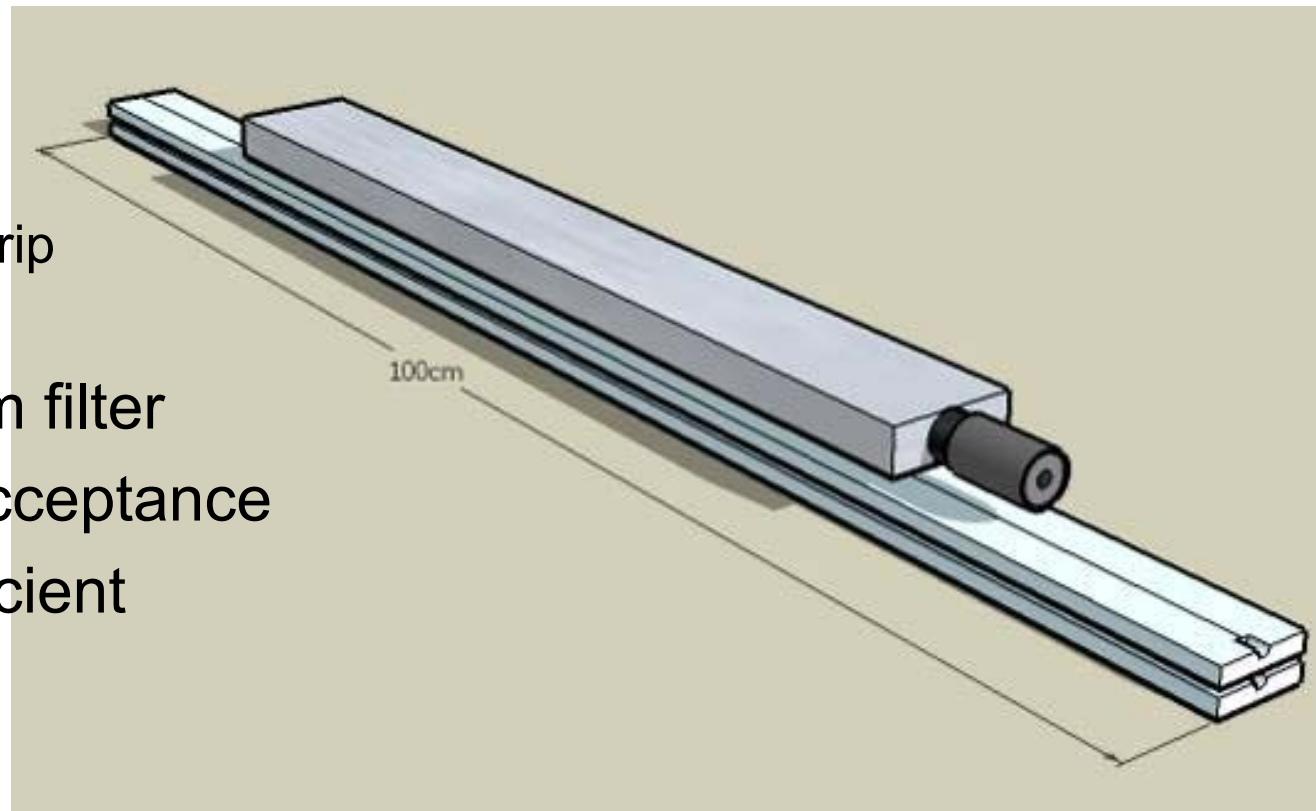

Electronics

Hamamatsu 100pix MPPC (1mm^2) x 2

V bias= 69.8V, no temperature control

Shaping high gain amps with $t_{\text{shape}} = \sim 15\text{ns}$
(FWHM for pulses $\sim 35\text{ns}$)

Measure peak voltage using Agilent 5341B
digital scope

Typical event

- no really - this is typical.
- Cosmic trigger paddle signal not shown

Signals are shown with opposite polarity for clarity

horiz = 20ns/div
vert = 100mv/div

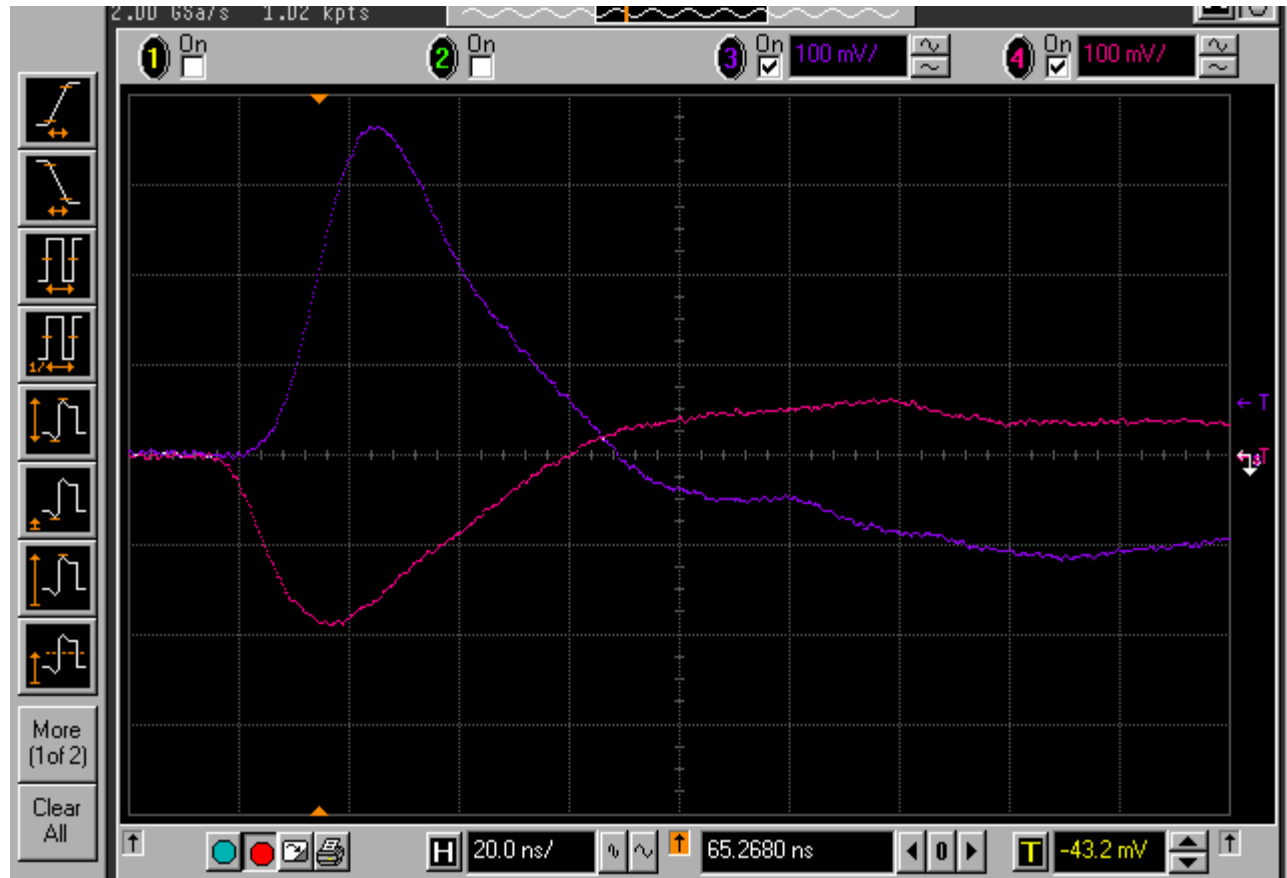

Self calibrating

- its very easy to see individual photo peaks
- 10mv/div, 20ns/div
- Self triggered for these pics
- Both channels shown at same Vbias

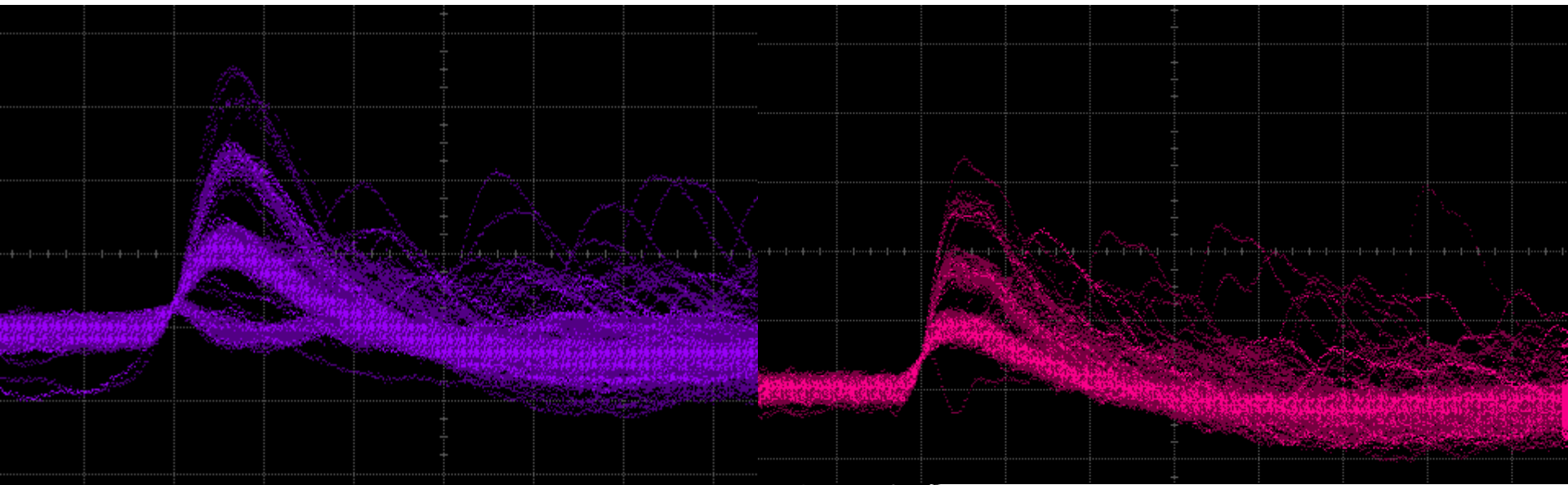

Ch4, self triggered

- Use this to calibrate mv/pe – shown lin scale

Self trig noise on C4

0pe peak
cut off by
self trig
threshold

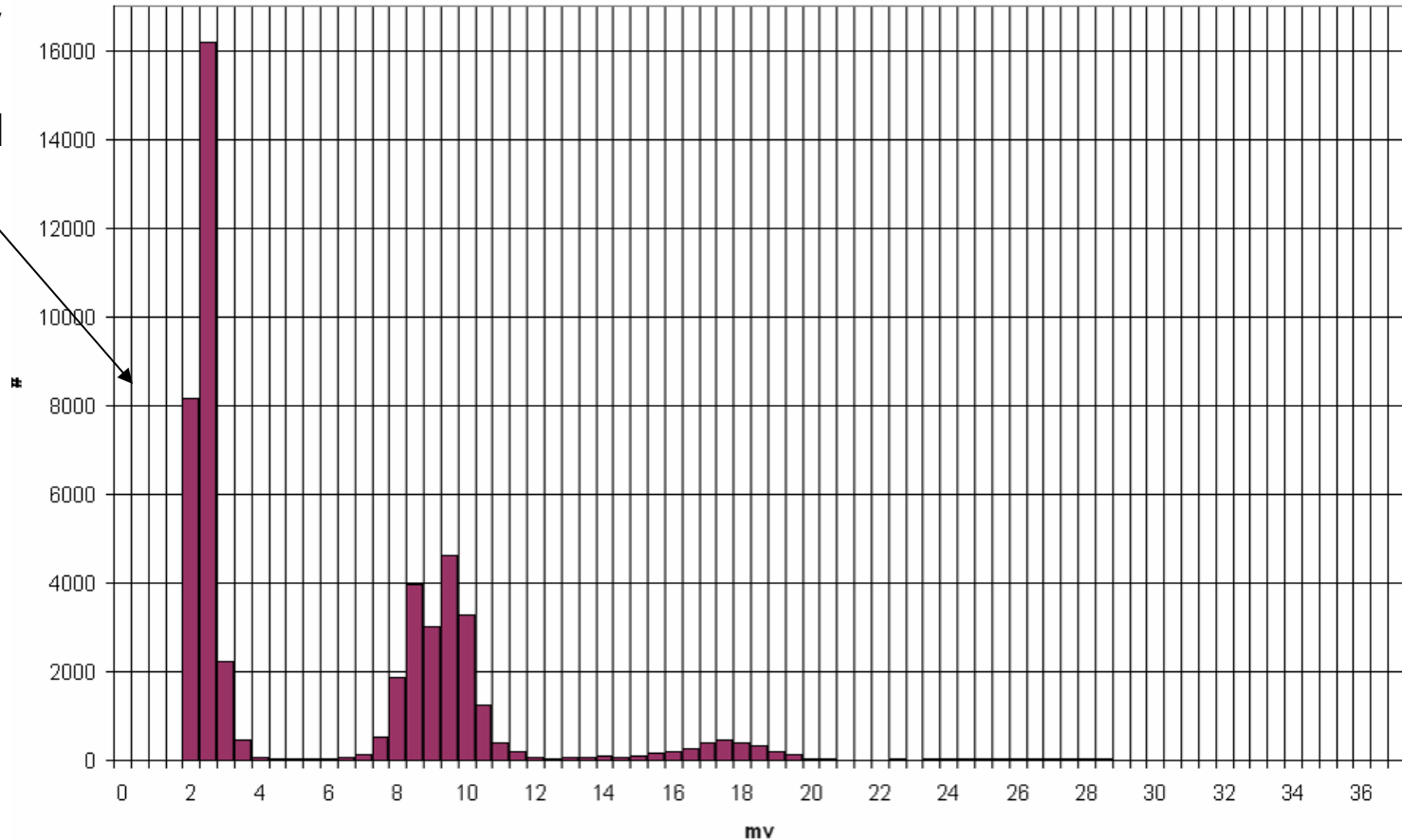

Ch4, self triggered

- Use this to calibrate mv/pe – shown log scale

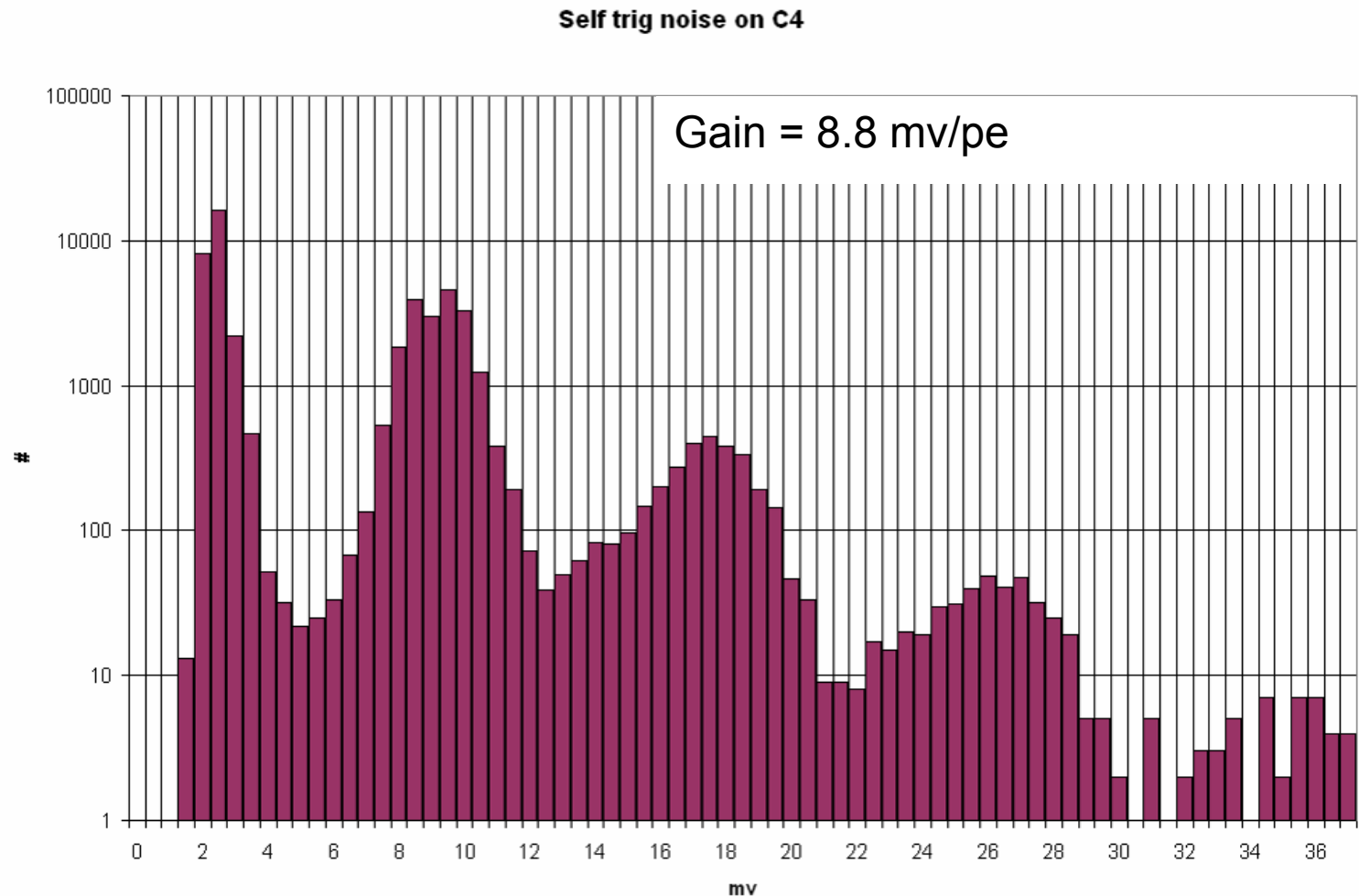

note: in the setup, it is not guaranteed that particles that trigger must cross this strip (though it is better for upper strip than lower strip)

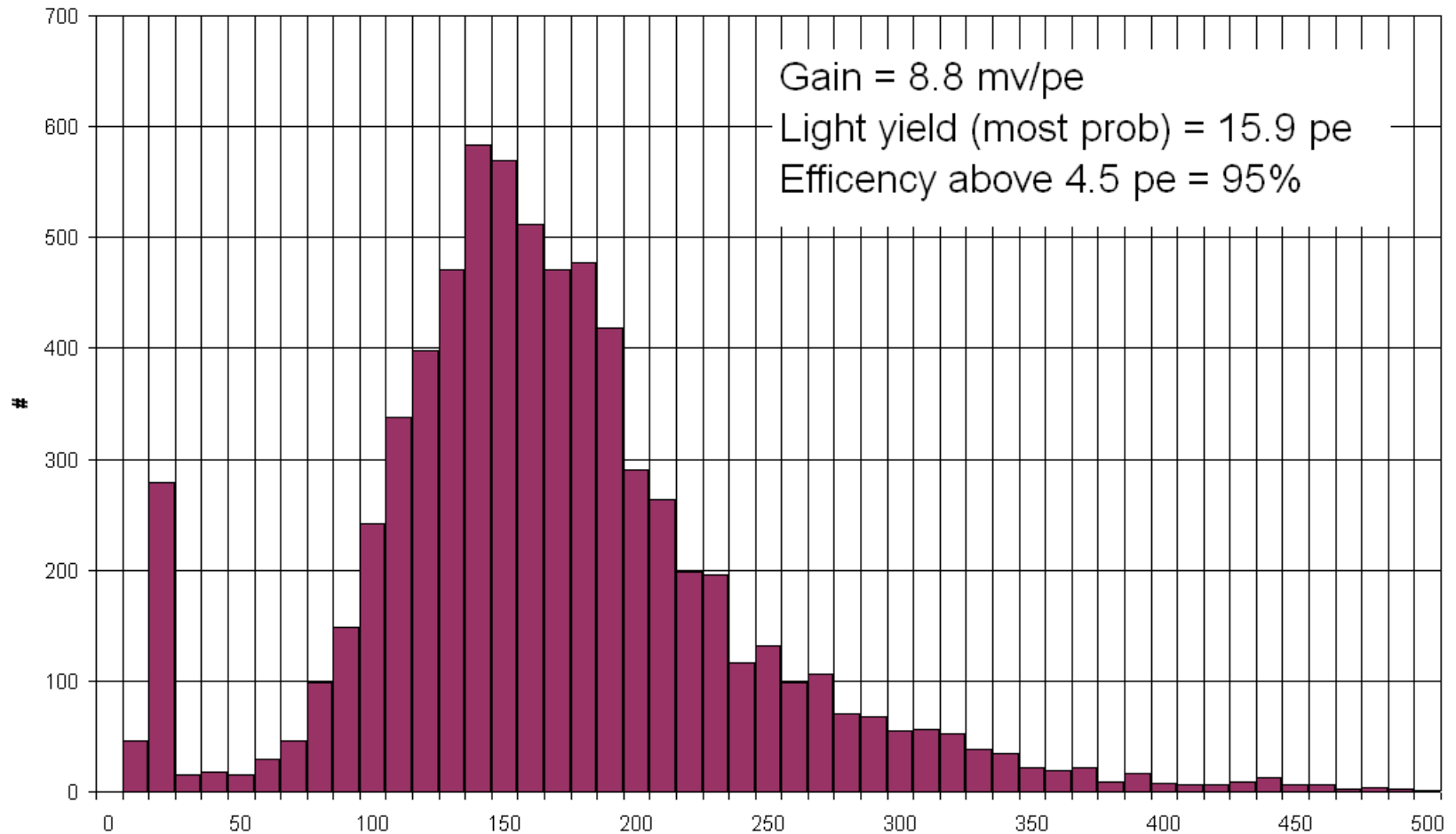

Ch3, self triggered

- Use this to calibrate mv/pe – shown lin scale

0pe peak cut off by slef trig threshold

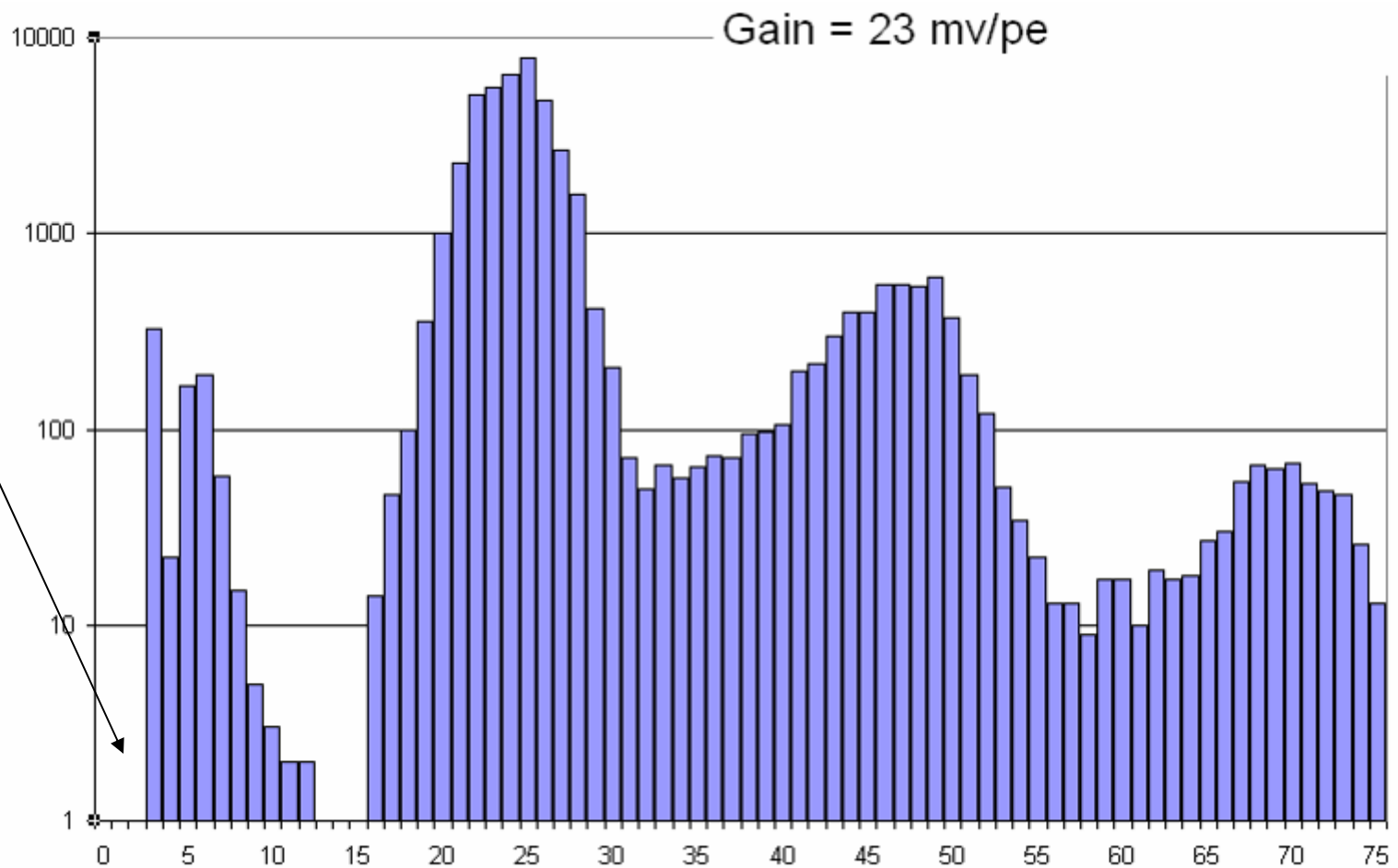

MPPC Tests at Wayne State

S. Gollapini, K. Gunthoti, P. Karchin, A. Gutierrez

Goals

- study devices with pixel sizes of 25, 50 and 100 microns
- measure gain of as a function of bias voltage
- compare methods for measuring gain: resolved photopeaks versus Poisson analysis

Method

- use fast (13.6 ns) light pulse from LED
- record pulse charge distribution with 10x LeCroy amplifier and LeCroy QVT, using 75 ns wide input gate

Gain from resolved photopeaks:

$$G = \frac{(0.025 \text{ pC/channel}) \times (\# \text{ channels between peaks})}{1.6 \times 10^{-19} \text{ C}}$$

Gain from Poisson analysis:

$$\sigma^2 = \langle (Q - \langle Q \rangle)^2 \rangle$$

$$\langle G \rangle = \frac{\sigma^2}{\langle Q \rangle e}$$

$$\langle N_{pe} \rangle = \frac{\langle Q \rangle}{\langle G \rangle e}$$

100 micron device

Example of pulse charge spectrum

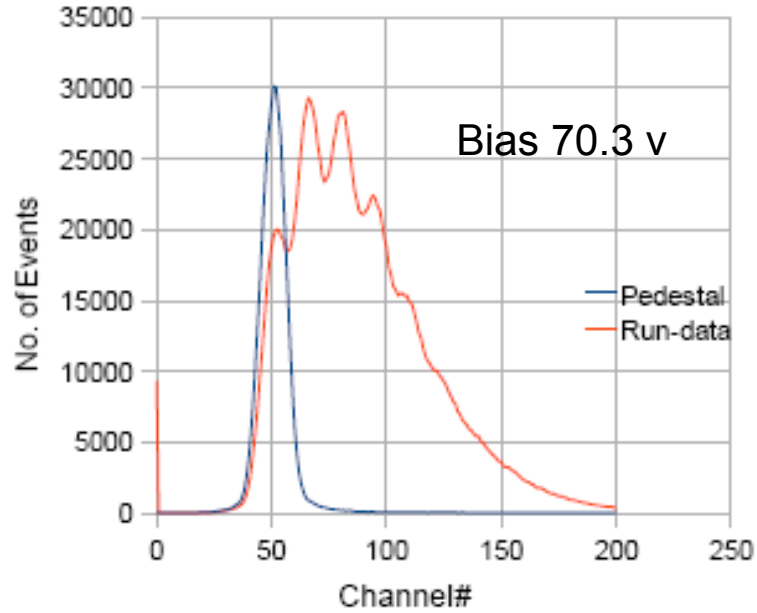

manufacturer's gain
2.39 e6 at 70.27 volts

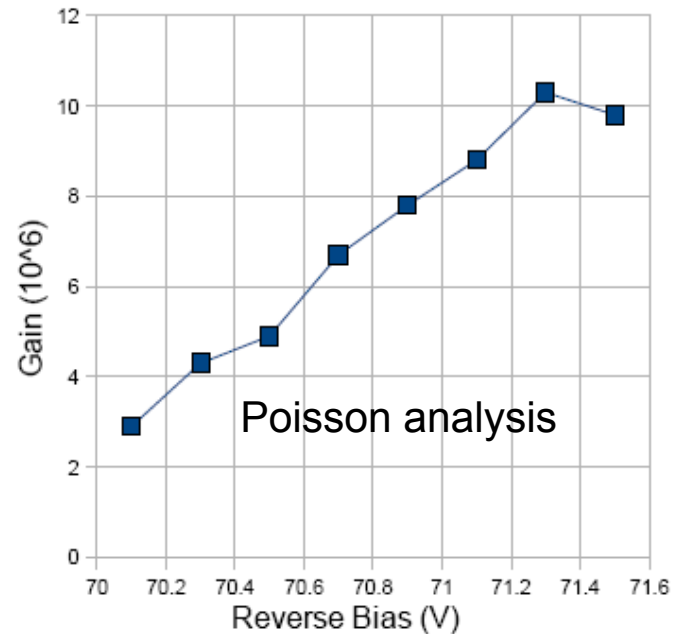
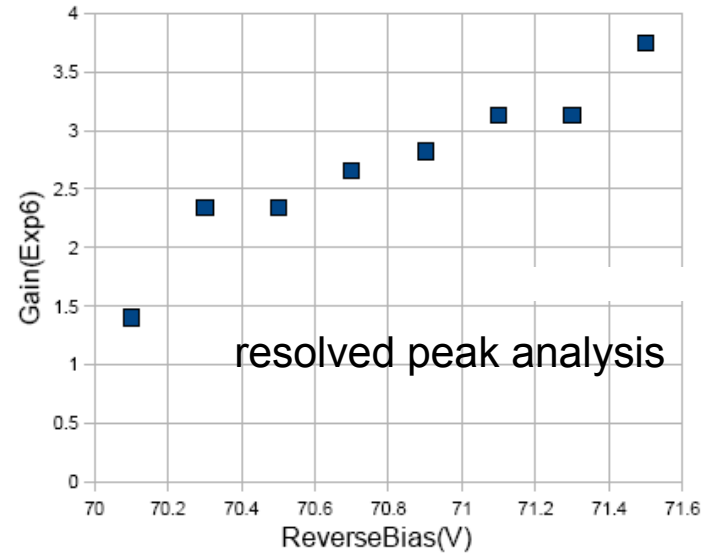

50 micron device

Example of pulse charge spectrum

RB = 69.7V

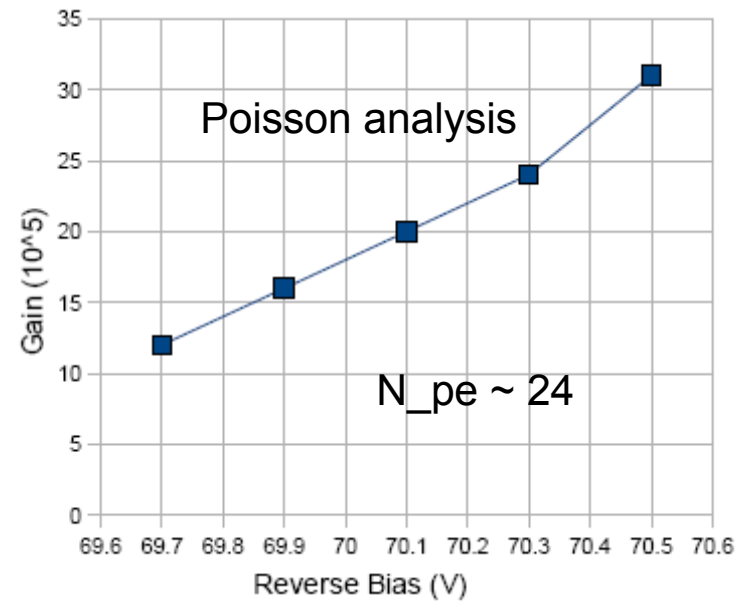
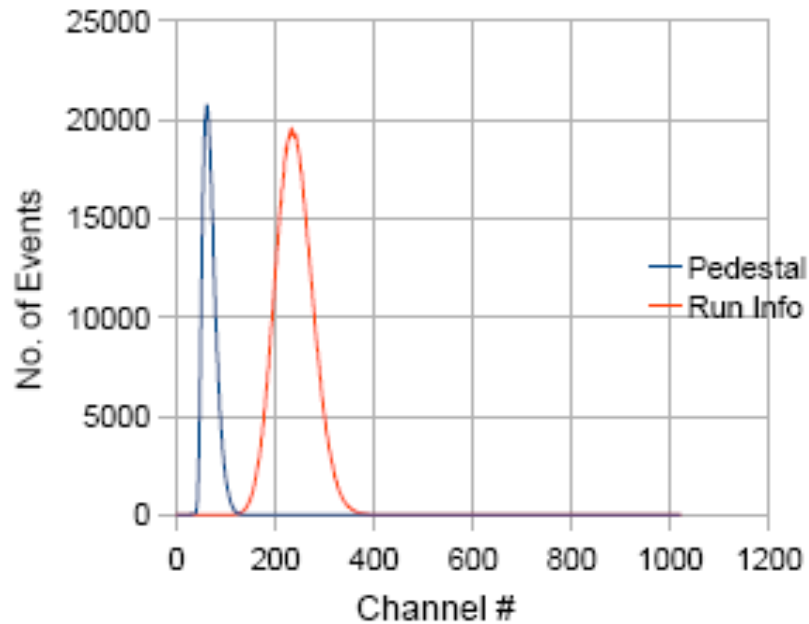

manufacturer's gain 7.5 e5 at 69.65 v

Conclusions & Observations

- gain measured with resolved photopeaks agrees with manufacturer's measurement
- Poisson-measured gain somewhat larger than resolved photopeak-measured gain – may be due to electronics noise broadening of pulse charge distributions
- only 100 micron devices can resolve photopeaks with the conventional electronics used
- bias voltages in a large system must be (individually?) controlled to accuracy ~ 0.1 v or better!

Custom IRST SiPM for muon/tailcatcher R&D

A. Driutti, D. Cauz, G. Pauletta – U. Udine/INFN Trieste

Geometry: circular
diameter: 1.2 mm
Microcell: $40 \times 40 \mu\text{m}$
Improved fill-factor (44%)
Breakdown voltage $\sim 30.5\text{V}$

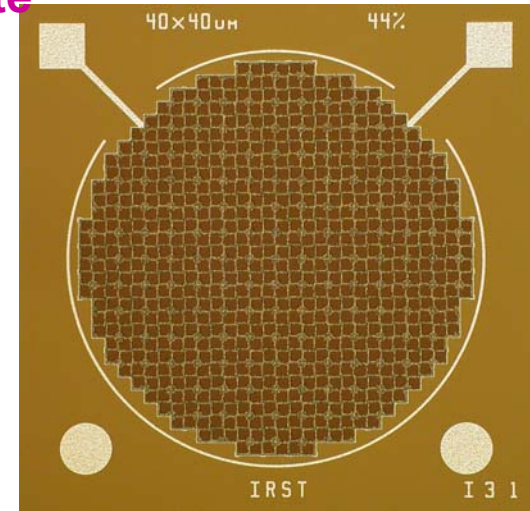

Inventory:

100 SiPMs packaged (T018)
photocathode protected by
epoxy(glob-top)

August 2008: 21 tested at SiDet
Very uniform characteristics for
20/21

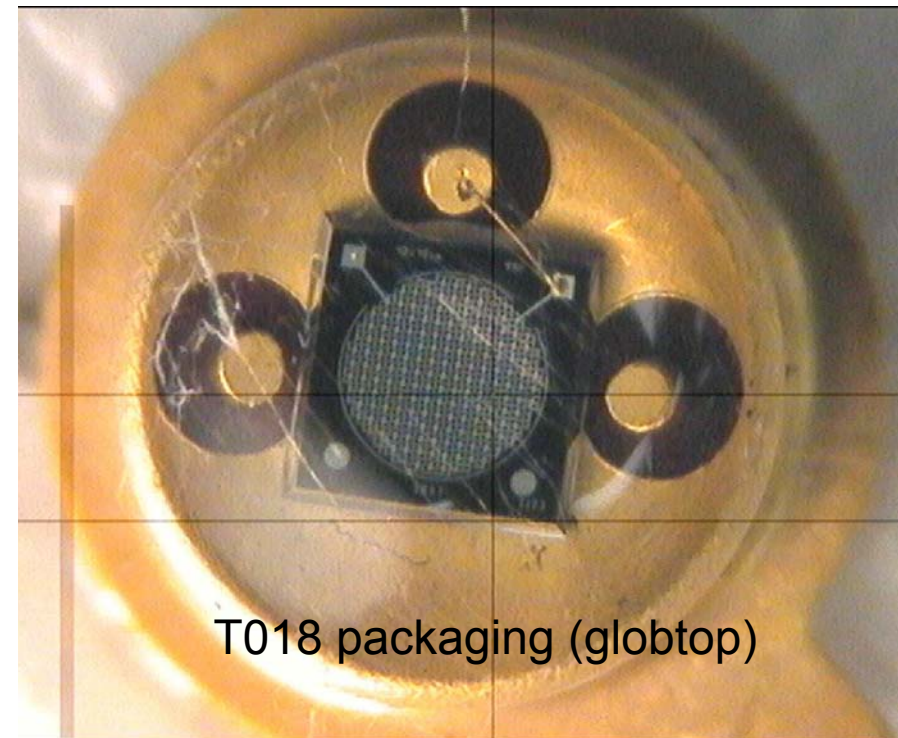

IV curves at room temp

I-V curve

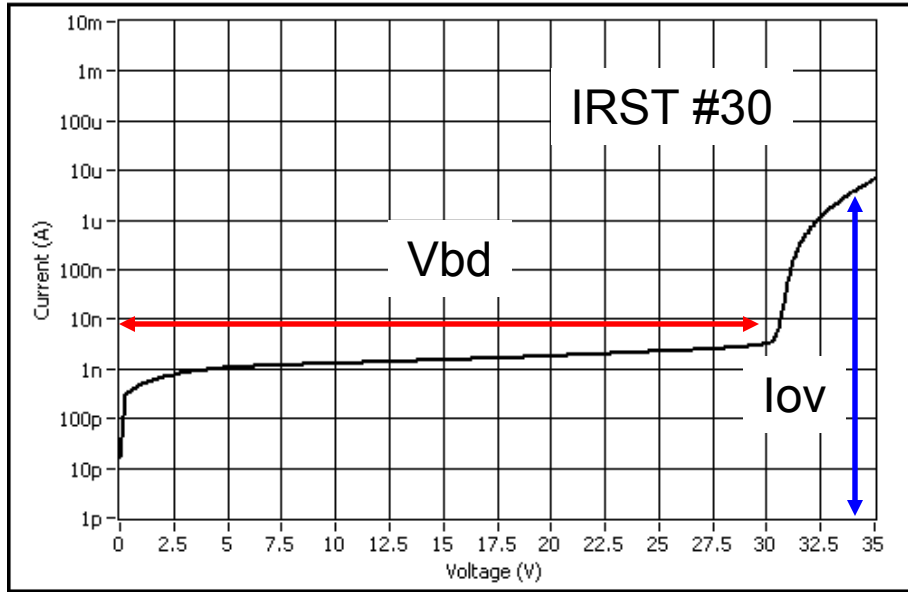

I-V curve

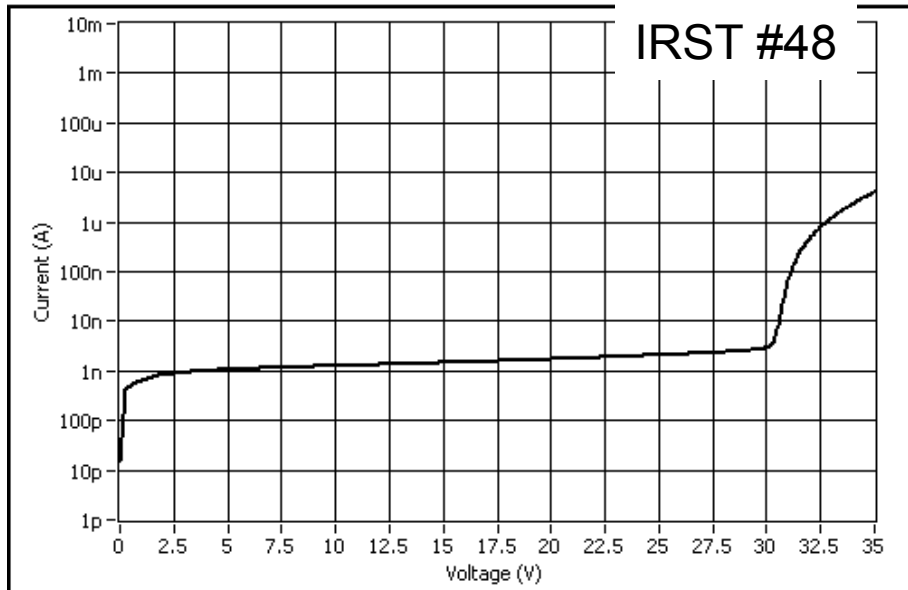

SiPM #	Vbd (V)	lov (uA)
30	30.4	4.7
31	30.4	3.5
32	30.5	3.2
33	30.6	3.9
34	30.5	3.8
35	30.5	3.7
36	30.6	4.7
37	30.5	5.2
38	30.3	4.6
39	bad	bad
40	30.4	4.3
41	30.6	2.2
42	30.6	1.8
43	30.7	3.5
44	30.7	3.2
45	31.7	4
46	30.3	1.9
47	30.3	2.7
48	30.3	2.8
49	30.4	1.7
50	30.3	4.9

- The breakdown voltage $\sim 30.5 \pm 0.2V$
- Operating range: $\sim 30.5 - 34.5$
- The current at overvoltage=4V ranges from 2 to 5 uA

IV and rates also measured function of temp

Dark count

Was also measured as a function of temp. and found to vary between $\sim 10^3$ and 10^6 (at room temp)

p.e./mip

Measurements in progress to determine the number of photoelectrons from mips in T956 scintillator bars.

In exp. T956 with the first SiPM prototypes (fill-factor $\sim 15\%$) we saw ~ 6 pe/mip.

With the improved fill-factor of these SiPMs (44%) we therefore expect much better.

V_{bd} as fn of temp
(preliminary analysis)

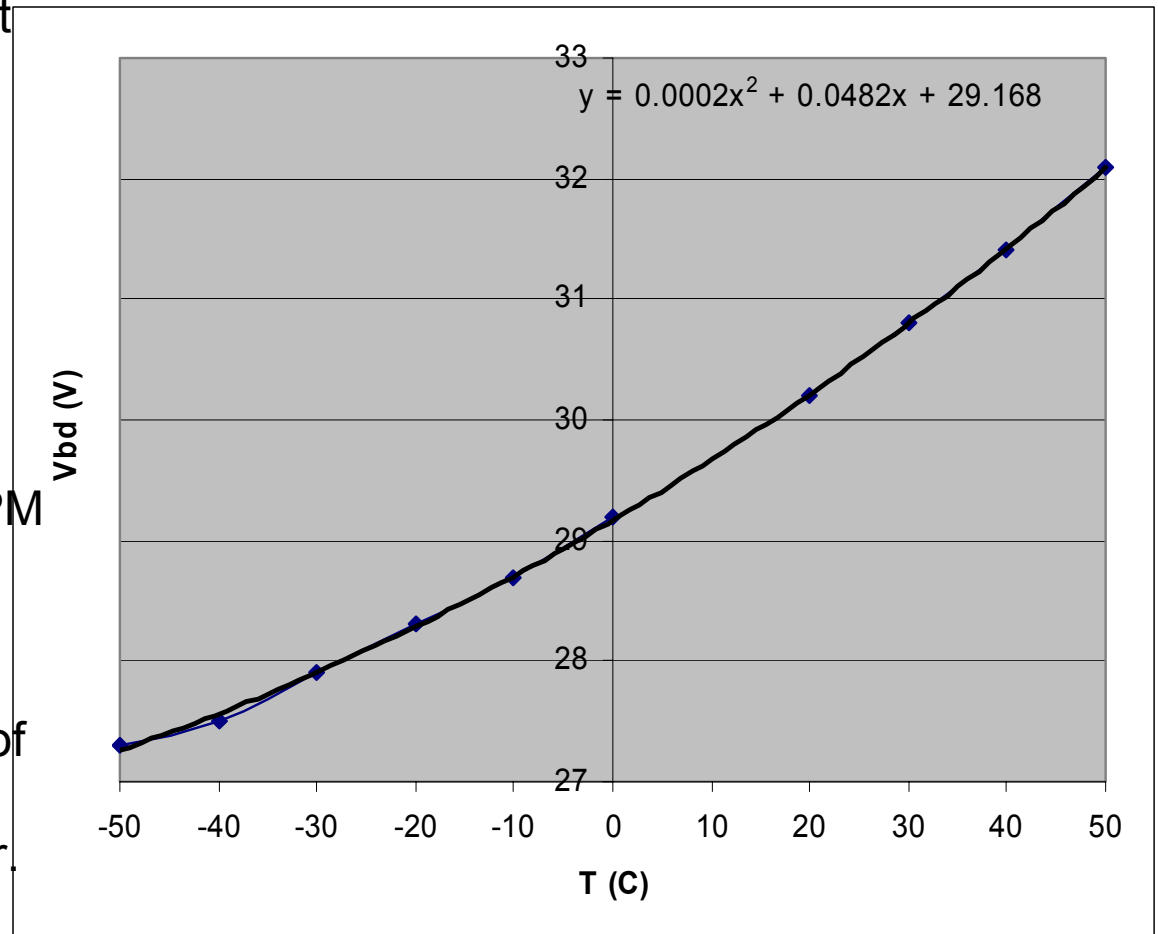

MPPC Studies at Notre Dame

B. Baumbaugh, M. McKenna, M. Wayne, R. Ruchti

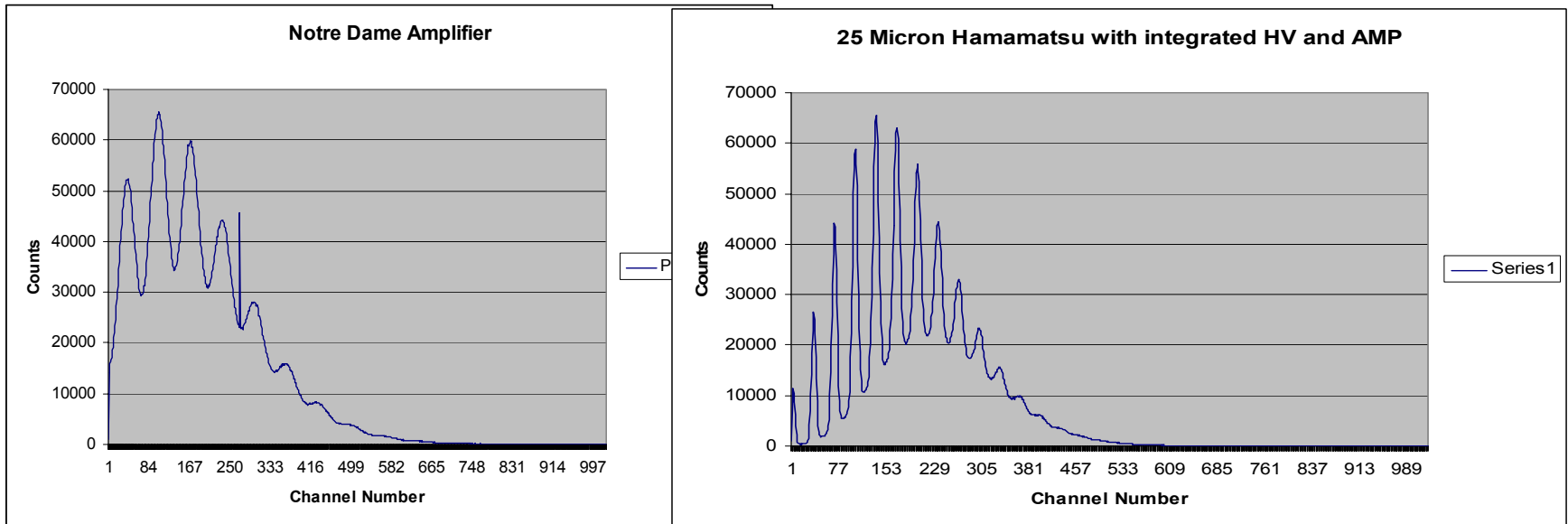

Noise level	LeCroy Discriminator and counter	Hamamatsu Board with integrated amplifier and discriminator
One and above	800 Khz	760 Khz
Two and above	75 Khz	75 Khz
Three and above	8.5 Khz	8.5 Khz
Four and above	1000 Hertz	900 Hertz

Hamamatsu MPPC Tests: Indiana University Sept. 2008

Greg Pauley (undergrad), Paul Smith (EE), Rick Van Kooten

Devices: Hamamatsu MPPC's, four each of:

100 mm, 100 pixels

50 mm, 400 pixels

25 mm, 1600 pixels

Setup: signal from pulsed green LED,

Canberra Model 241 amplifier, Ortec MCA with 50 nsec gate

Focus here on:

temperature studies: mounted on Peltier module with heat sink,
temperature readout at device.

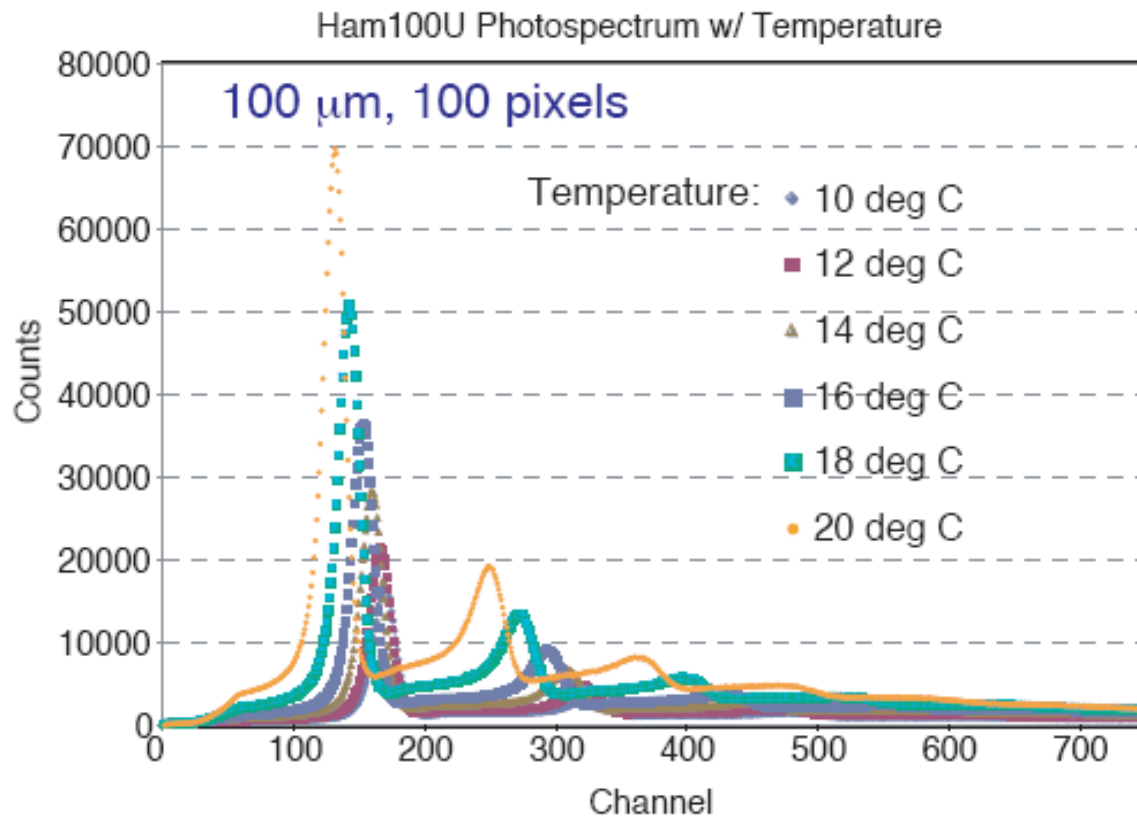

- 50 μm , 400 pixels: similar behavior
- 25 μm , 1600 pixels: have problems getting sensible spectra
- ~1/2 of devices showed extreme sensitivity to bias voltage (to level of 0.05 V in 70 V); vendor's recommended bias appeared too close to threshold, ran at few 0.1 V above

- Using Poisson method, average gain of three 100 μm , 100 pixel devices @ 20 deg. C is found to be 6.35×10^6
- Variation of various properties with temperature:

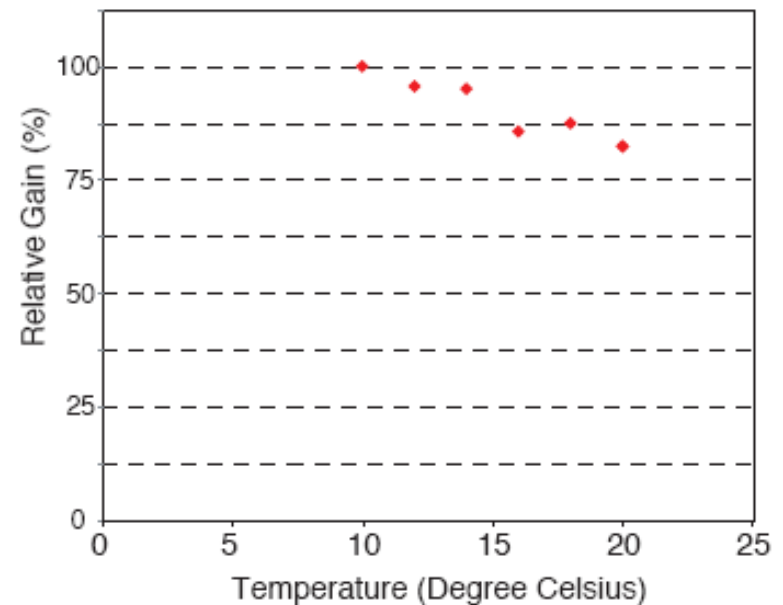
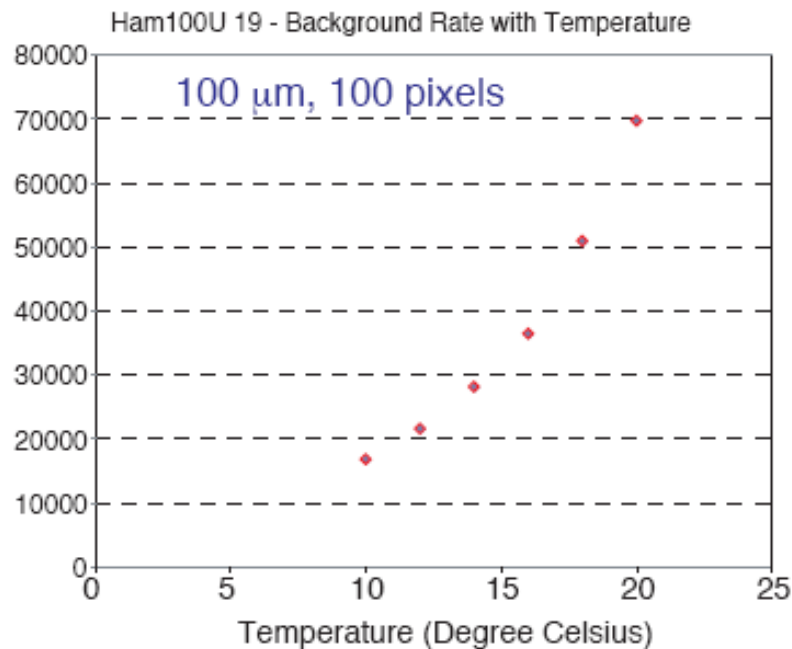

- Similar for 50 μm , 400 pixel devices; struggling with 50 μm devices

Summary

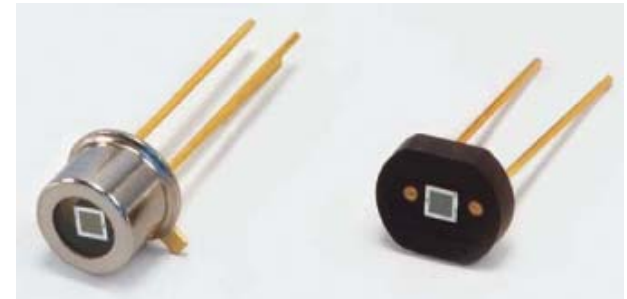

- R&D studies with RPCs/KPIX and Scintillator/SiPMs is advancing at Argonne, SLAC, Fermilab and institutes here and abroad plus many universities, for calorimetry and muon detection after significant use in Europe and Asia.
- Several companies are now marketing these devices.
- This will prompt future activities for packaging and integrated circuit development in the particle physics domain and beyond.
- We should keep pressing for more than generic development, because new technology opens new doors in our science. And those doors need to be open.

Teststand

- RPC test stand with BaBar spares
- Available Gases
 - **BaBar streamer gas - 34.9% Freon 134a, 60.6% Argon, 4.5% isobutane**
 - **BaBar avalanche gas – 75.5% Freon 134a, 19.4% Argon, 4.5% isobutane, 0.6% CF6**
 - **Argon**
 - **Ordered CERN/ANL**
 - **94.5% Freon 134a, 5.0% isobutane, 0.5% CF6**
- Trigger - 10 Hz
 - **3-fold coincidence**
Trig1*Trig3*IHEP 2

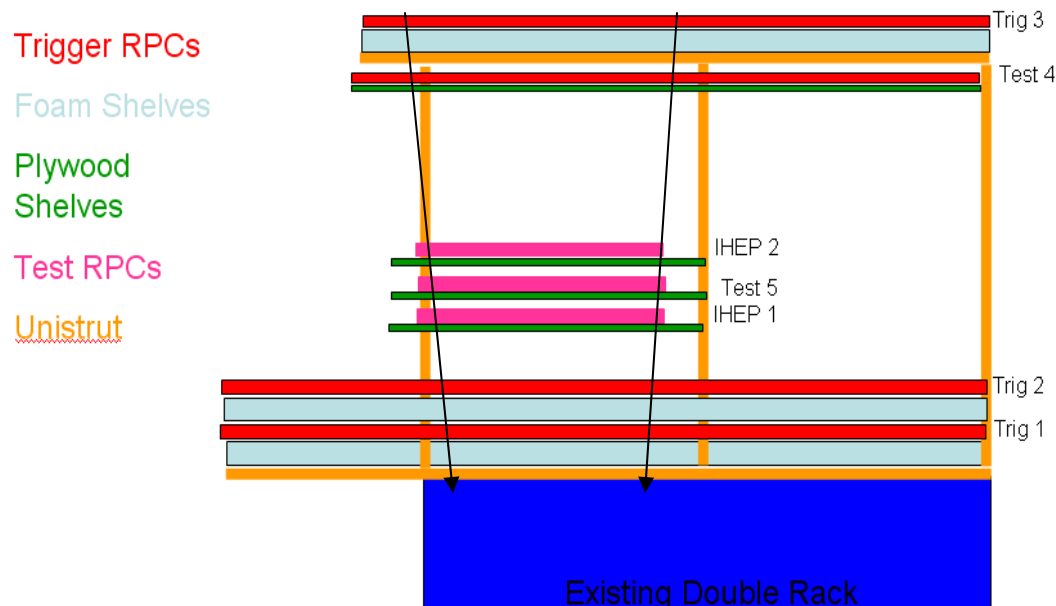

- Available RPCs
- IHEP 0.5 by 0.5 m (4 + 6)
- Italian Bakelite 0.5 by 0.5 m
- BaBar spares 1.1 by 1.3-1.6 m



RPC/KPIX

RPC

Strip plane

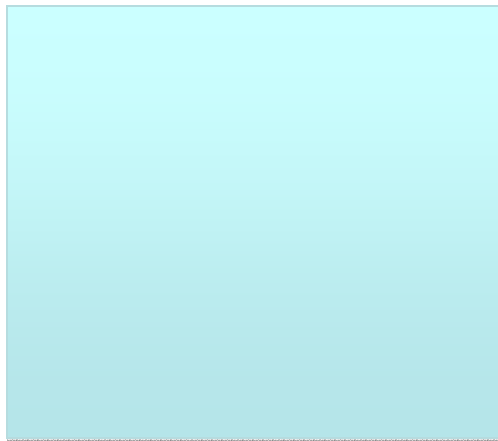

Ground plane

□ Strip termination

X 12

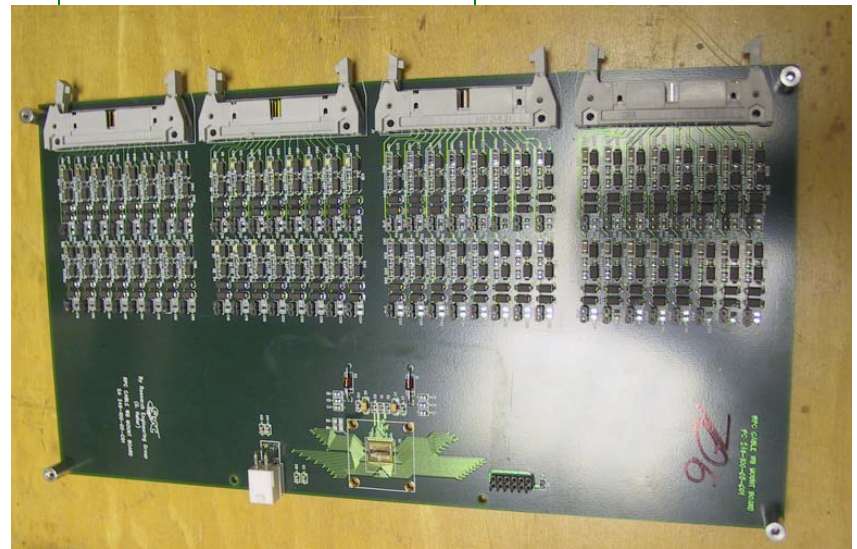
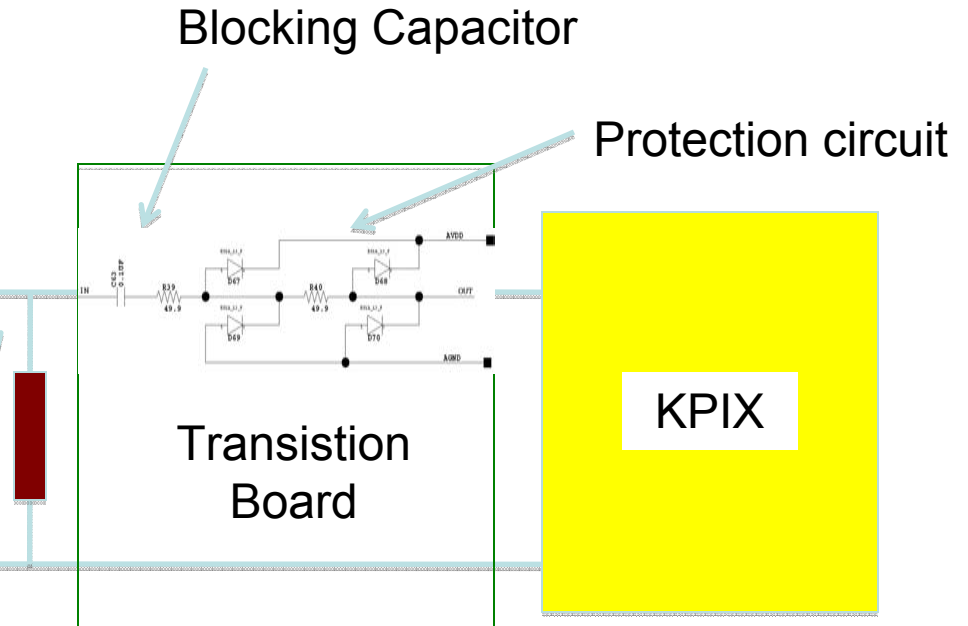

Trigger coverage ?

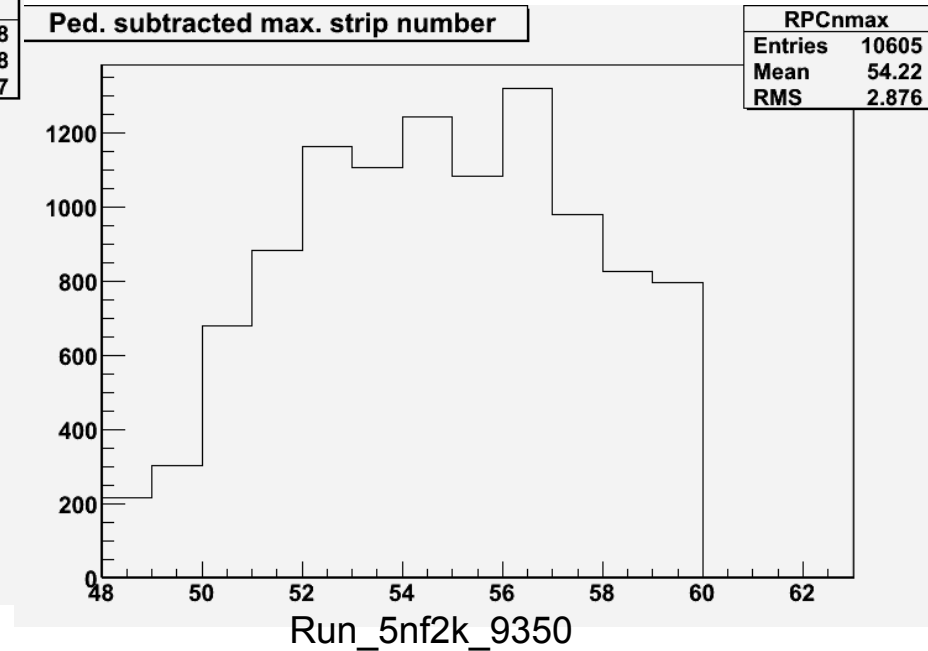
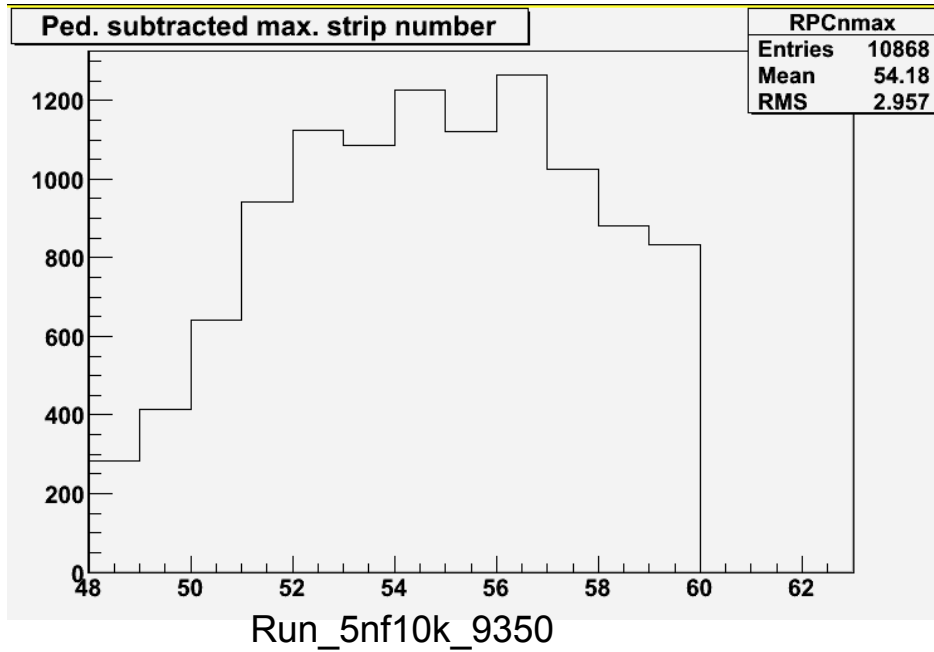

Preferred

Operation

ANL – Magill
Prague 05?

Avalanche mode

- Faster (~10kHz)
- Lower HV
- Smaller signal (~1pC)
- Needs pre-amplifier
- Better long-term prognosis
- No multiple streamers

Streamer mode

- Slower (~1kHz)
- Higher HV
- Large signals (~100pC)
- Sharp signal
- Multiple streamers

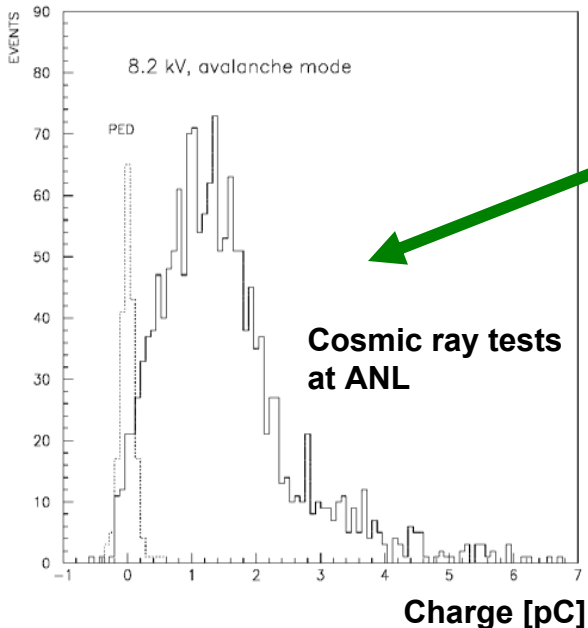
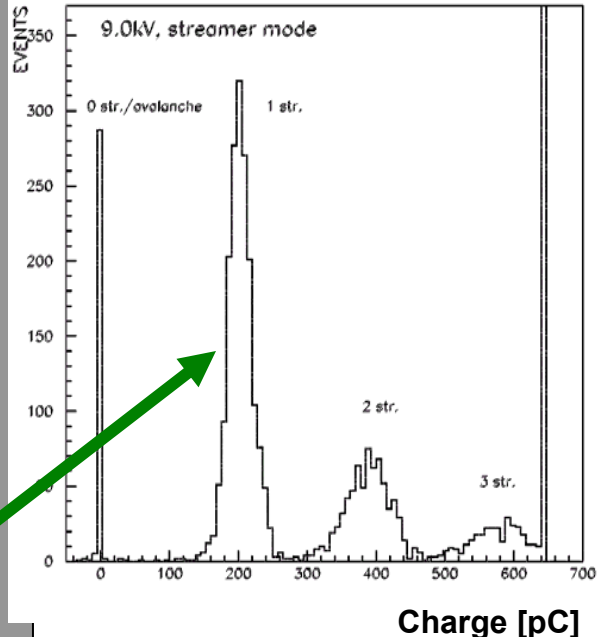

Cosmic ray tests
at ANL

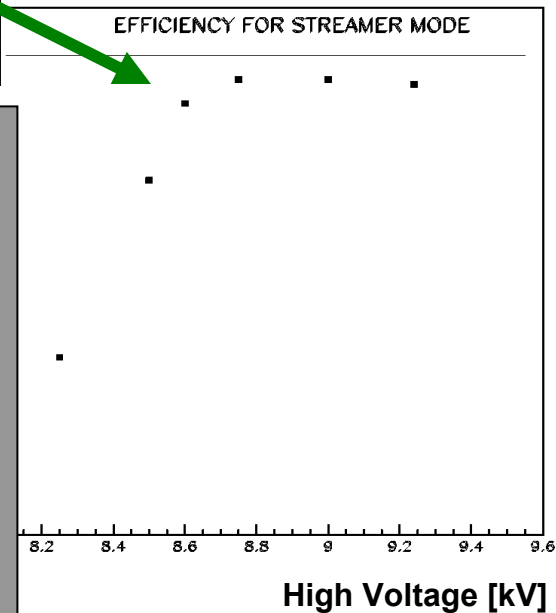

Gas Mixture

Freon/Argon/IsoButane 62:30:8

Used by Belle (does not suppress streamers)

Freon/IsoButane/SulfurHexafluoride 90:5:5

Used by HARP (suppresses streamers)

Many more...

Andy White – ANL work

CALICE talk 04

DHCAL - RPC-based

- Large single pad to cover whole chamber
- Trigger: cosmic ray 'telescope'
 - Signal rate $\sim 1\text{Hz}$, trigger area $\sim 10 \times 10\text{cm}^2$
- Analog readout: 'RABBIT' system (CDF)
 - Measure total charge of a signal
 - Charge resolution $\sim 1.1\text{fC}/\text{ADC bit}$, dynamic range $\sim -6\text{pC}$ to $\sim +60\text{pC}$, very low noise level
 - Multi-channel readout

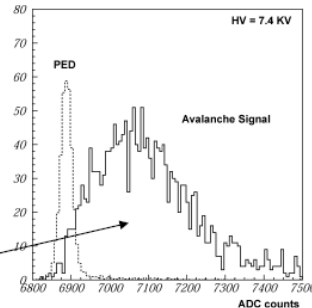

- Two modes of operation
 - **Avalanche**
 - Average signal charge: 0.2 - 10+ pc
 - Lower operating voltage
 - Typical efficiency $\sim 99\%$
 - Very low noise level
 - Rate capability $< 1\text{kHz}/\text{cm}^2$
 - **Streamer**
 - Average signal charge: 10 - 100+ pc
 - Higher operating voltage
 - Typical efficiency $\sim 90\%$
 - Rate capability $\sim 10\text{Hz}/\text{cm}^2$
 - Multiple streamers

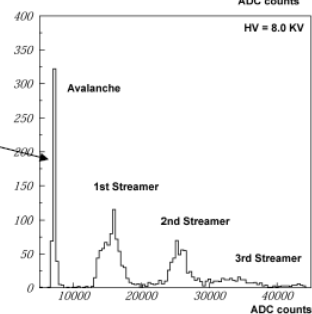

in RPCs in

