

HAMAMATSU

HAMAMATSU PHOTONICS K.K.

SOLID STATE DIVISION

1126-1 ICHINO-CHO, HIGASHI-KU, HAMAMATSU CITY

435-8558, JAPAN

TEL: (81)53-434-3311, FAX: (81)53-434-5184

Power supply module for MPPC

C11204-01

OPERATION MANUAL

Be sure to read the operation manual carefully before this board is used.
If operated differently from the standard procedure in the manual,
a serious accident may occur.
Keep this manual for future reference.

Doc. No. K29-B61072

Rev. G Sep. 1, 2014

TABLE OF CONTENTS

I . OVERVIEW

II . PRECAUTIONS FOR USE

BE SURE TO READ THIS SECTION BEFORE USE!

III . FUNCTIONS

IV . OPERATION METHOD

V . SPECIFICATIONS

VI . NOTICE

I . OVERVIEW

The C11204-01 is a high-voltage power supply that is optimized for driving HAMAMATSU MPPC (multi-pixel photon counter) series. It can provide up to 90V output. By connecting an external analog temperature sensor, the C11204-01 has built-in temperature compensation function that MPPC can be operated optimally even if an environment temperature is changed. It has built-in the output voltage monitor function and the output current monitor function. All functions can be controlled from a PC via the serial interface. The C11204-01 is available in a 16-lead hybrid board.

■ Features

- Wide output voltage range: 50V to 90V
- Low ripple noise: 0.1mVp-p typ.
- Good temperature stability: ± 10 ppm/ $^{\circ}$ C typ.
- High setting resolution: 1.8mV
- MPPC current monitor
- Serial communication

II . PRECAUTIONS FOR USE

- When using this product please be sure to comply with all caution items to avoid possible trouble or accidents. We are constantly making every effort to improve product quality and reliability but this does not guarantee complete safety when using this product. In particular, when this product is to be used in equipment or systems which might cause personal injury, fatal accident or damage to property if handled improperly, be sure to implement safety measures that take potential problems fully into account. In such applications, we bear no responsibility for problems or damage arising from use of this product.
- Do not disassemble any part of this module. Changing the adjustment or modifying this module may cause malfunctions and lead to fire or electrical shock. And, this module contains a place of high-voltage (DC ~90V), which is essential to operate the APD. If your hands or elsewhere come in contact with parts at a high voltage, shocks or injuries may result. If the circuit is shorted by mistake, it may be a source of problems.
- High-voltage power supply is installed in the product which is absolutely imperative to operate MPPC array. To avoid electric shock, you must not touch when turning on or 10 seconds after turning off the power.
- Reproduction or copying of this manual is prohibited without permission of Hamamatsu Photonics.
- If this manual is lost or damaged, immediately contact our sales office to ask for an additional copy.

III. FUNCTIONS

■ Setup

This function can set the output voltage to any value. The output voltage is decided by setting the reference voltage $V_b[V]$, the reference temperature $T_b[^\circ\text{C}]$, the primary temperature coefficient $\Delta T[\text{mV}/^\circ\text{C}]$, and the secondly temperature coefficient $\Delta T'[\text{mV}/^\circ\text{C}^2]$. It can be done a "temperature compensation" and "output voltage setting", by setting each parameter.

All setting of the C11204-01 uses serial communication (UART). The details of the communication are described for "C11204-01 Command Reference.pdf".

If you use an evaluation kit C12332, please refer to an operation manual of C12332.

1) Output voltage setup

This function can set the output voltage to any value. The output voltage is decided by setting the reference voltage $V_b[V]$ (Cf. Fig. 1). Please use command of "Set the temperature correction factor" to set it (Cf. C11204-01Command Reference).

Please refer to Chapter V for the output voltage range and the setting accuracy.

2) Temperature compensation

This function performs temperature compensation of the output voltage using the temperature $T[^\circ\text{C}]$ of the external temperature sensor.

The output voltage $+HV[V]$ is determined by the following formula.

$$+HV = (\Delta T' * (T - T_b)^2 + \Delta T * (T - T_b)) / 1000 + V_b$$

Where $\Delta T[\text{mV}/^\circ\text{C}]$ is temperature coefficient, $T[^\circ\text{C}]$ is temperature of the external temperature sensor. Temperature coefficient $\Delta T[\text{mV}/^\circ\text{C}]$ can set to four parameters of high temperature side coefficient $\Delta T'1[\text{mV}/^\circ\text{C}^2]$, $\Delta T1[\text{mV}/^\circ\text{C}]$ and primary low temperature side coefficient $\Delta T'2[\text{mV}/^\circ\text{C}^2]$, $\Delta T2[\text{mV}/^\circ\text{C}]$ (Cf. Fig. 1). If you don't use this function, please input 0 into $\Delta T'1$ and ΔT .

When B departs from the operating temperature limit greatly, the temperature compensation becomes OFF forcibly.

■ Monitor

It can be measured the output voltage +HV[V], output current I_d [mV], and external temperature sensor value T [°C]. (Cf. Fig. 2). Please refer to Chapter V for the accuracy.

■ ON/OFF switch

It is a function to ON / OFF the output voltage. In the case of state [ON], the voltage is output. In the case of state [OFF], the output voltage becomes 0V.

■ Overcurrent protection

This function stops the output of the high voltage when the current flows from the greater than or equal to the threshold C11204-01.

When current load exceeded a threshold level more than four seconds, the output voltage becomes 0V. The threshold of the default is 3mA. When you want to output the high voltage again, please send a reset command or reboot the C11204-01.

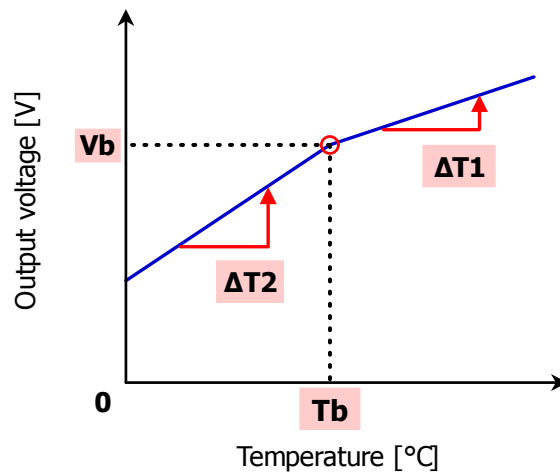

Fig. 1

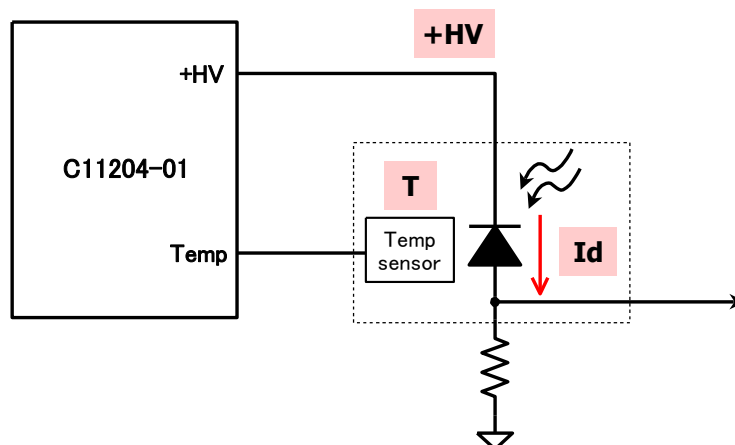

Fig. 2

IV. OPERATION METHOD

Note: If you use an evaluation kit C12332, please refer to an operation manual of C12332.

1. Power Supply Pin (Vcc)

Connect the power supply voltage to this pin. In this case, please connect a bypass capacitor between the GND. The bypass capacitor should be connected near the pin as possible.

2. High Voltage Output Pin (+HV)

Connect HAMAMATSU MPPC Series to this pin (Cf. Fig. 3). This pin must be connected to low pass filter to suppress the ripple noise (Cf. Fig. 3). Low ESR capacitors should be used at the output to minimize the output voltage ripple.

3. RXD Pin and TXD Pin (RXD, TXD)

These are used for serial communication. The RXD should be connected to a TXD of host. Similarly, the TXD should be connected to a RXD of host. Refer to Command Reference for the communication specification.

The details of the communication are described for "[C11204-01 Command Reference.pdf](#)".

4. Temperature sensor Pin (Temp)

Connect analog temperature sensor (Texas Instruments; LM94021) to this pin (Cf. Fig. 4). Put a low-pass filter near this pin to remove a noise from C11204-01 (Cf. Fig. 3). The pin 1 and pin 5 of the temperature sensor must be connected to GND. **If you don't use a temperature sensor, this pin must be connected to GND. A temperature compensation may malfunction when it is not connected.**

5. Turn the power on

After the power is turned on, check whether excessive current is flowing the device and whether the device is operating abnormally, for example if smoke is coming out.

If any abnormal operation occurs, immediately power off.

Note1: High voltage is output immediately after the power is turned on.

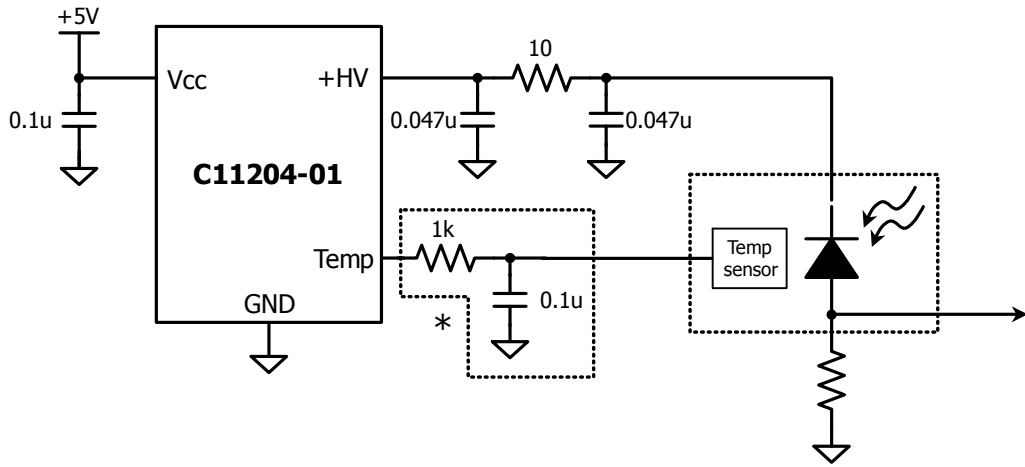

Fig. 3

*: It is recommended to be put near Temperature sensor Pin.

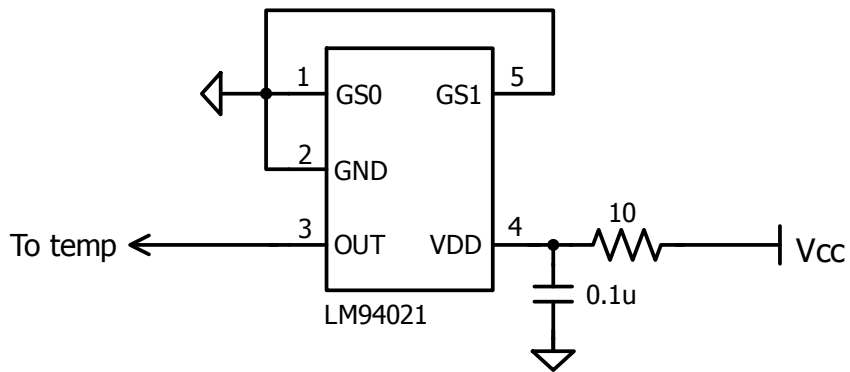

Fig. 4

V. SPECIFICATIONS

■ Specifications

■ Absolute maximum ratings

Parameter	Condition	Value	Unit
Power supply		6	V
Operating temperature	No condensation	0 to 50	°C
Storage temperature	No condensation	-20 to 70	°C

■ Specification(Typ. Ta=25°C, Vcc=+5V,unless otherwise noted)

Parameter	Condition	Min.	Typ.	Max.	Unit
Output voltage	No load	-	50 to 90	-	V
Output current		0	-	2	mA
Ripple noise (Note 2)	+HV=72V, No load	-	0.1	0.2	mVp-p
Setting accuracy	+HV=72V, No load	-	±10	±40	mV
Setting resolution		-	1.8	-	mV
Temperature stability	25±10°C, +HV=72V, No load	-	±10	±20	ppm/°C
Output voltage monitor accuracy	+HV=72V, No load	-	±10	-	mV
Output current monitor accuracy	+HV=72V, Id=1.0mA	-	±0.05	-	mA
Interface (Note 3)		Serial communication (UART)			
RXD, Input Low Voltage		0	-	0.2Vcc	V
RXD, Input High Voltage		0.65Vcc	-	Vcc	V
RXD, Input setup		90	-	-	ns
RXD, Input hold time		90	-	-	ns

■ General ratings

Parameter	Condition	Min.	Typ.	Max.	Unit
Power supply		4.75	5	5.25	V
Consumption current	+HV=72V, No load	15	20	25	mA

Note 2: In use recommended circuit.

Note 3: Need PC communication module.

■ Dimensional outlines (Unit: mm)

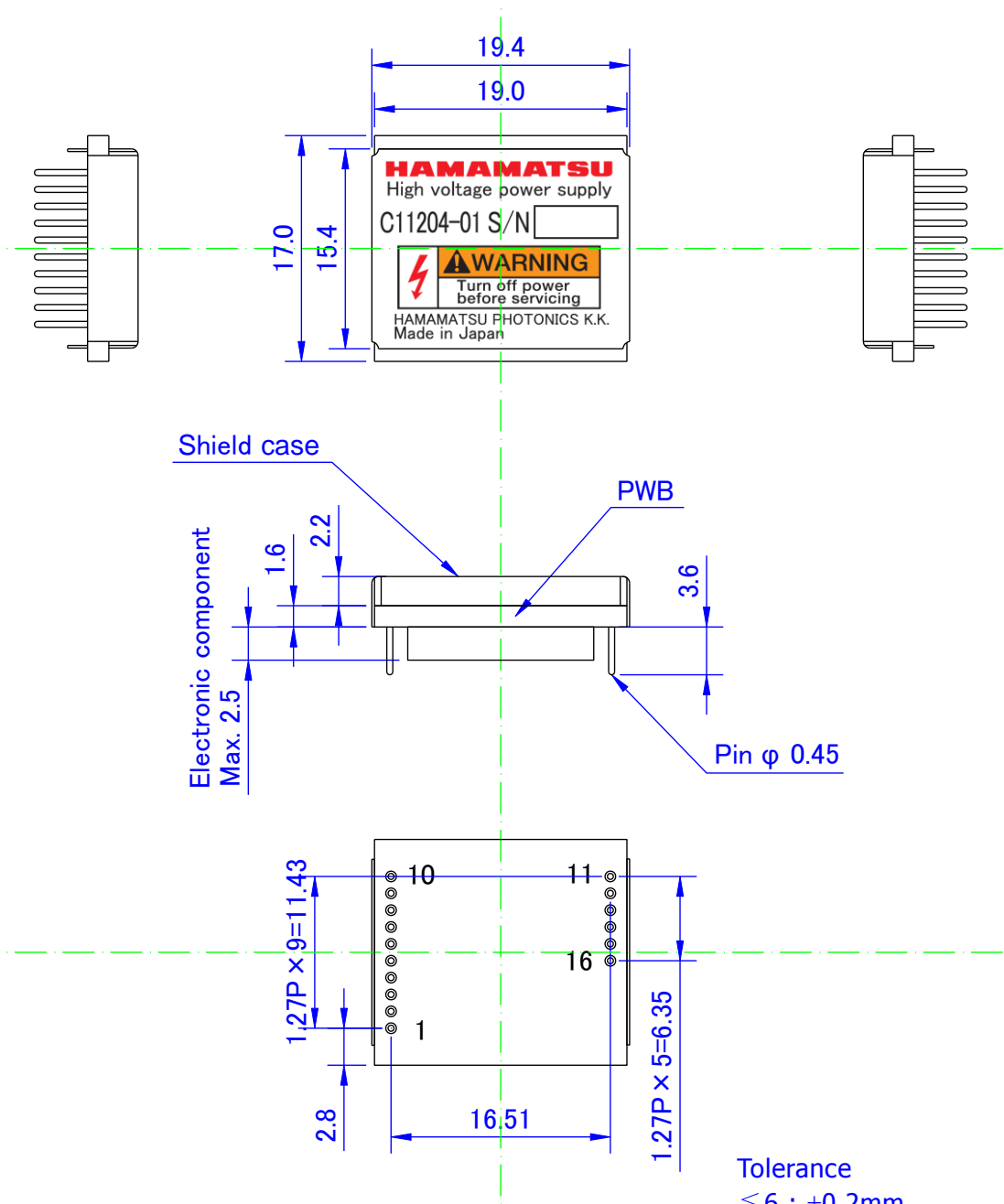

Tolerance
 ≤ 6 : ± 0.2 mm
 $6 <$ ≤ 30 : ± 0.25 mm

Fig. 5

■ Pin configuration

TOP VIEW

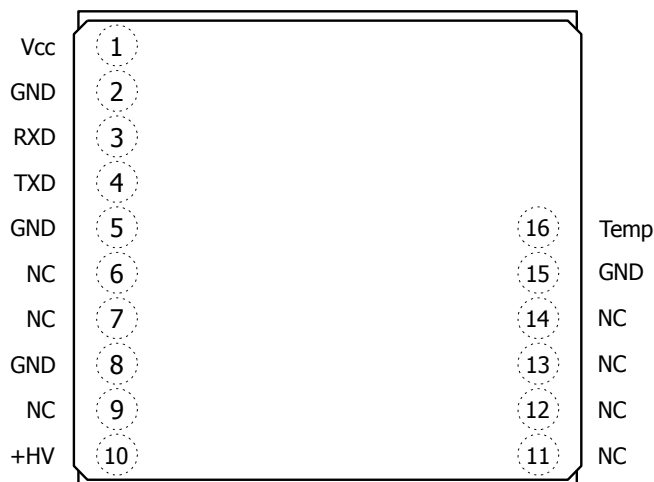

16-LEAD (19.4mm×17mm) hybrid board

Fig. 6

Pin function descriptions

Pin No.	Symbol	Description
1	Vcc	Power Supply Pin. Please supply +5V. This pin should be decoupled to GND by a bypass capacitor.
2, 5, 8, 15	GND	Ground. Pins are connected internally. For best performance, connect both pins to board ground.
3	RXD	Serial Data Input Pin.
4	TXD	Serial Data Output Pin.
6, 7, 9, 11-14	NC	No Connection.
10	+HV	High Voltage Output Pin. (<i>Note 4</i>)
16	Temp	Analog temperature sensor connection pin. (<i>Note 4</i>)

Note 4: Please refer to Chapter III.

■ Characteristic example

- Ripple noise (+HV=72V)

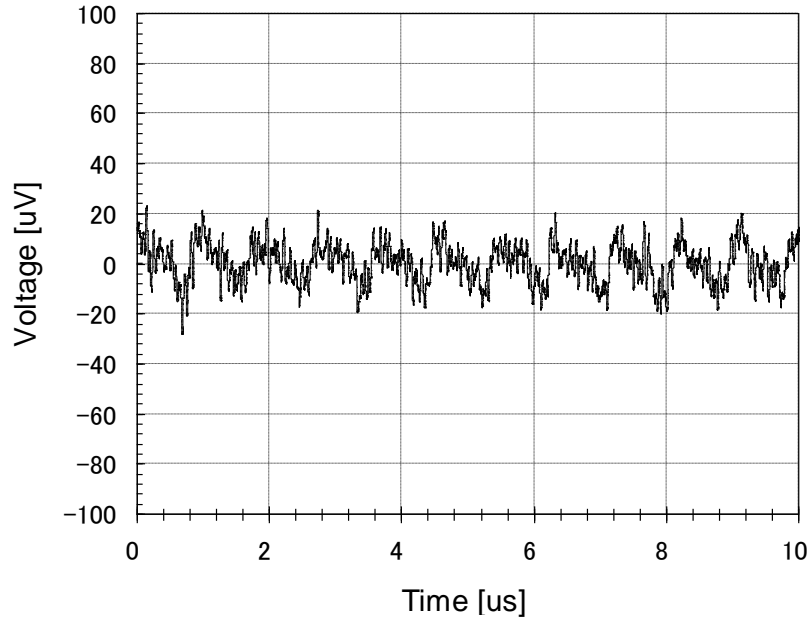

Note 1: In use recommended

Fig. 7

- Temperature dependence

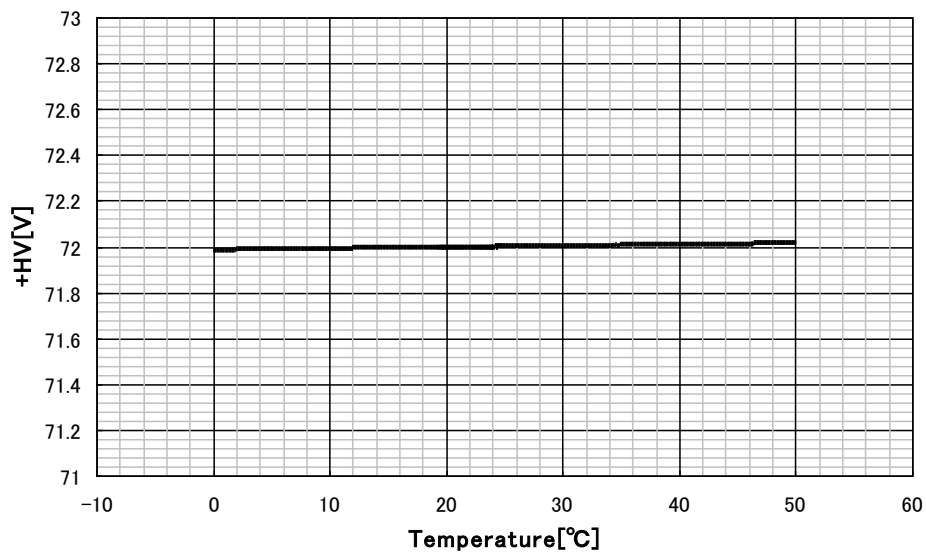

Fig. 8

- Current load

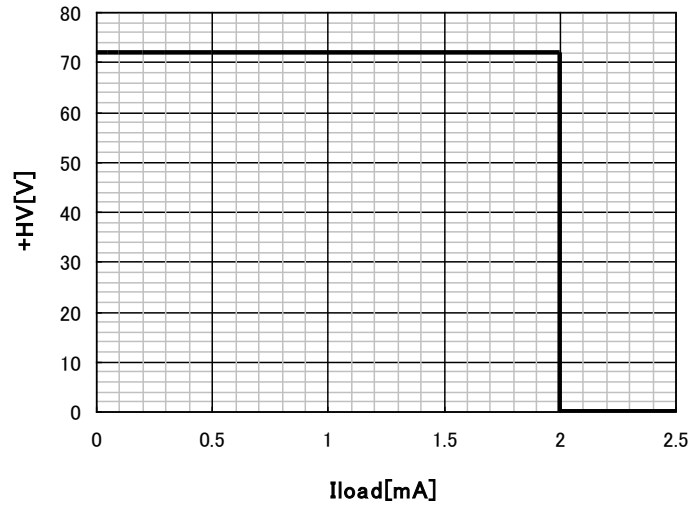

Fig. 9

- Consumption current (+HV=72V)

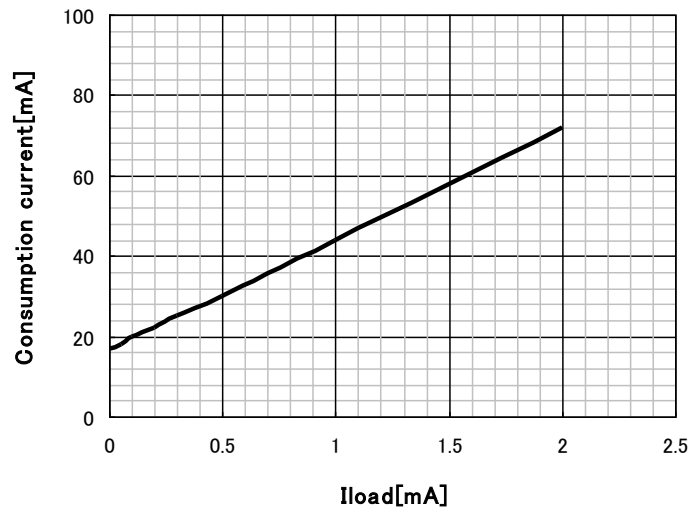

Fig. 10

VI. NOTICE

Hamamatsu Photonics K.K.(HPK) has made every effort to enhance the reliability of its semiconductor devices; however ,the possibility of defects cannot be entirely eliminated. In order to minimize risk of damage or injury arising from a defect in an HPK semiconductor device, the customer must be familiar with the property of such devices, and utilize appropriate safety measures in the design of equipment incorporating the devices. These measures may include, but are not limited to, redundancy, fire-containment, and anti-failure design features.

This product is warranted to the original purchaser for a period of 12 months following the date of shipment. The warranty is limited to replacement or repair of any defective material due to defects in workmanship or materials used in manufacture. It does not cover loss or damage of the product due to natural calamity or misuse, even within the warranty period.

In no circumstances, should these semiconductor devices be used by persons unfamiliar with their properties and limitations, or who lack proper knowledge of safe, electronic design.

HAMAMATSU

HAMAMATSU PHOTONICS K.K., Solid state division

1126-1, Ichino-cho, Higashi-ku, Hamamatsu City, 435-8558, Japan

Telephone: 053-434-3311, Fax: 053-434-5184