

The SuperHPS Concept: “Making Physics Great Again”

Matt Graham,
Takashi Maruyama,
Tim Nelson

SLAC

HPS NEXT - 1/8/16

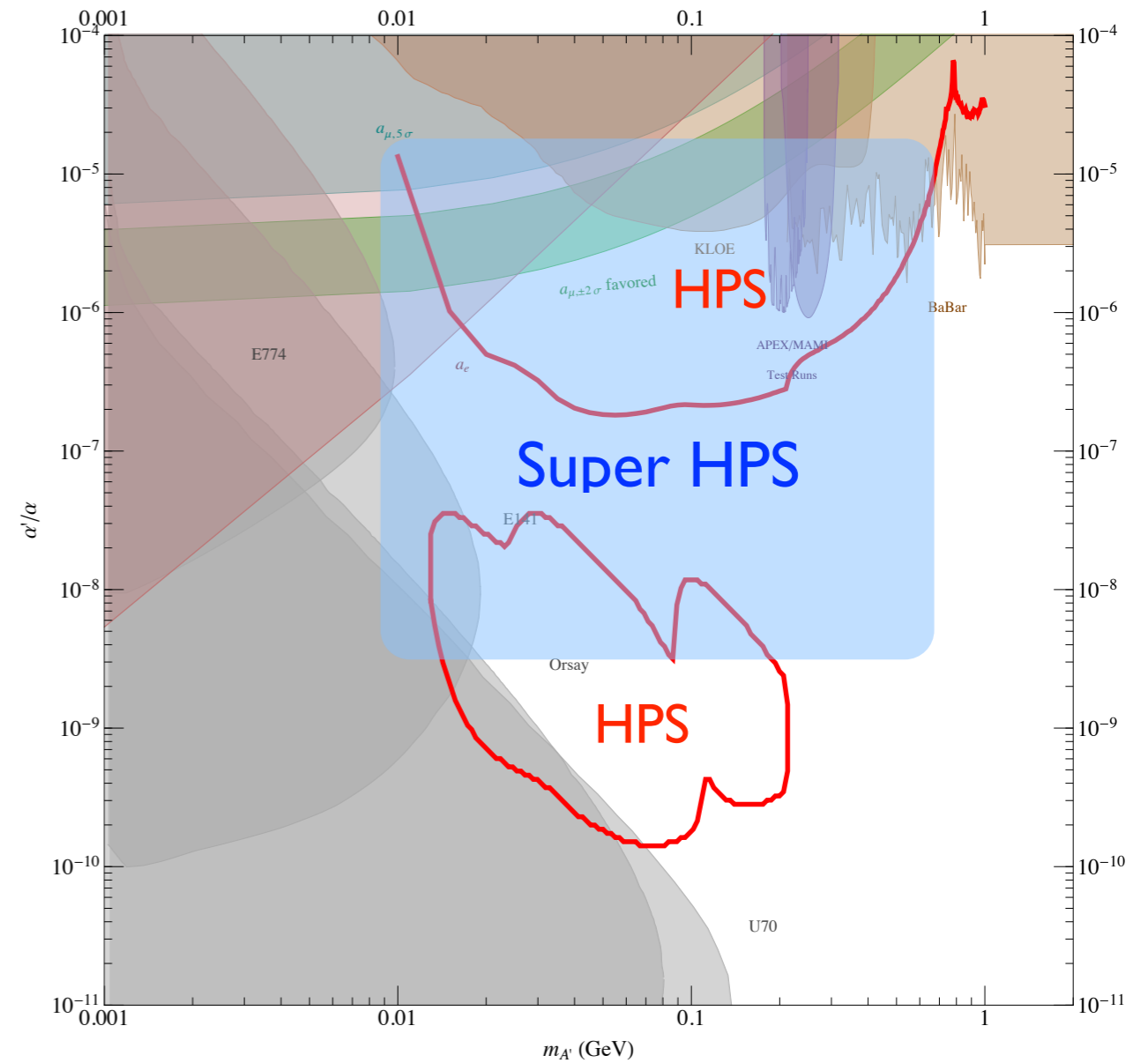

Introduction

- A few specific concepts were briefly explored for “Snowmass 2013” for next-generation dark photon searches.
- These studies assumed experiments would be operated at JLab's CEBAF.
- Among them, the “SuperHPS” concept turned out to be particularly interesting
 - The detector costs are undoubtedly higher than for HPS, but perhaps by less than originally thought.
 - In addition to expected performance gains, some additional strengths have been realized: these are critical to the feasibility of operating this experiment at SLAC.
- Further study is required to verify initial estimates, understand possible issues, optimize performance, and fully establish feasibility of the SuperHPS concept.

The Heavy Photon Search

- The Heavy Photon Search is a search for a dark or “heavy” photon using the CEBAF 12 beam at JLab.
- The electron beam is directed onto a tungsten foil, radiating heavy photons which then decay to e^+e^- pairs.

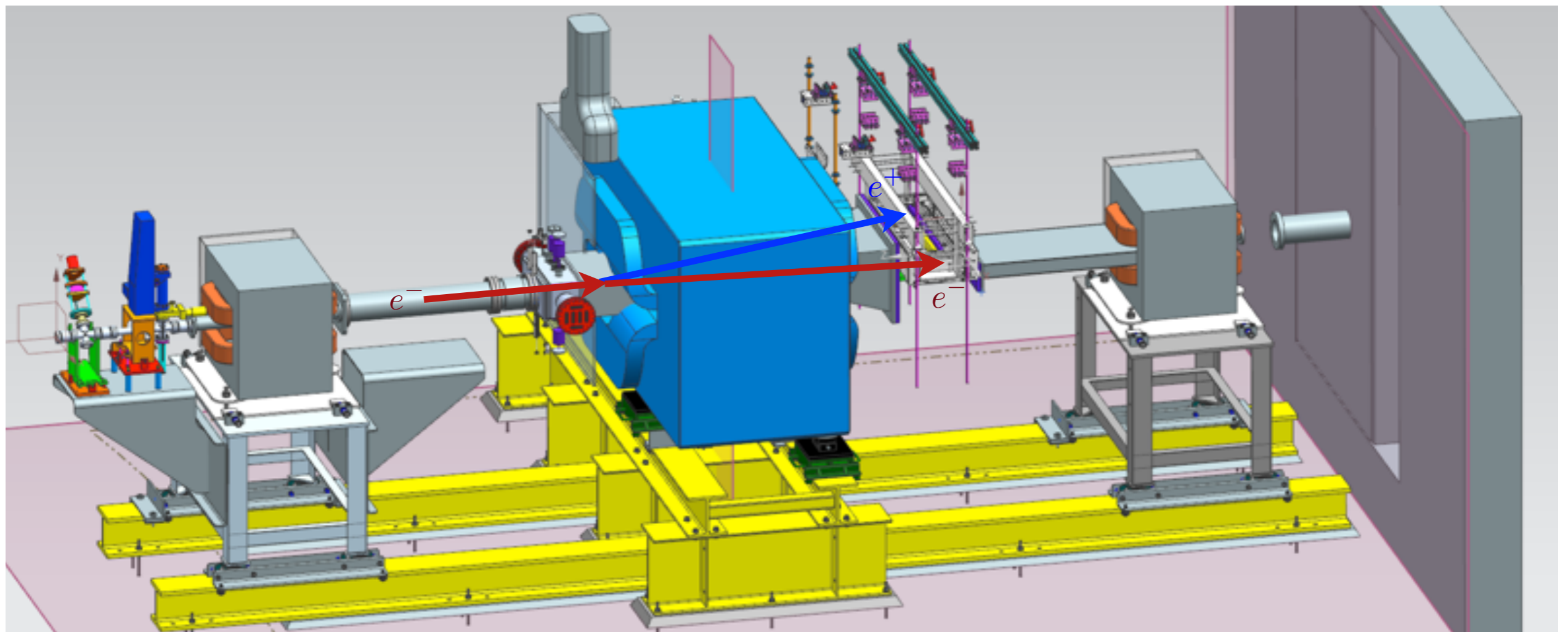
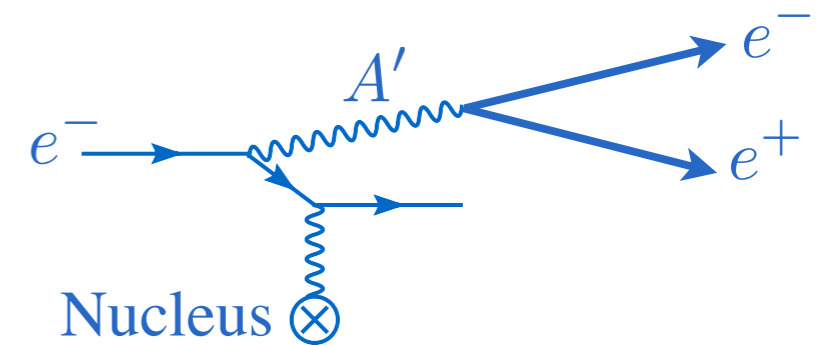

HPS Setup at JLab

Silicon Vertex Tracker
BUILT AT SLAC

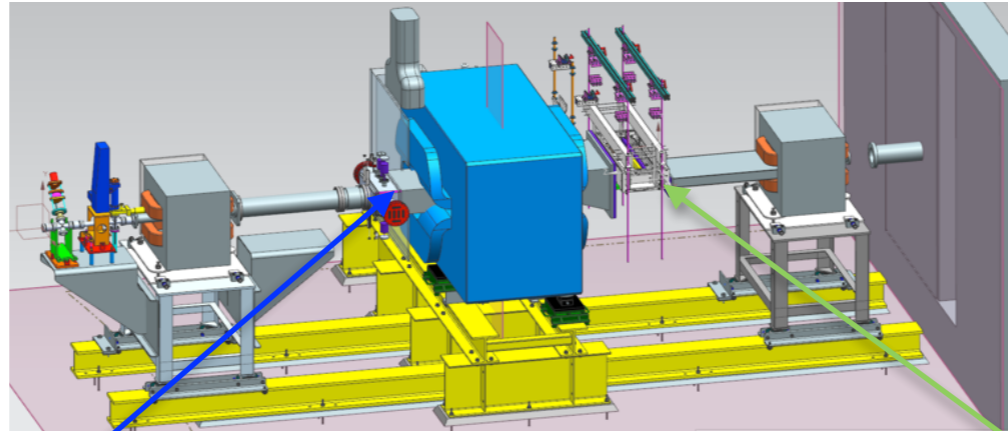

ECal
Built at JLab

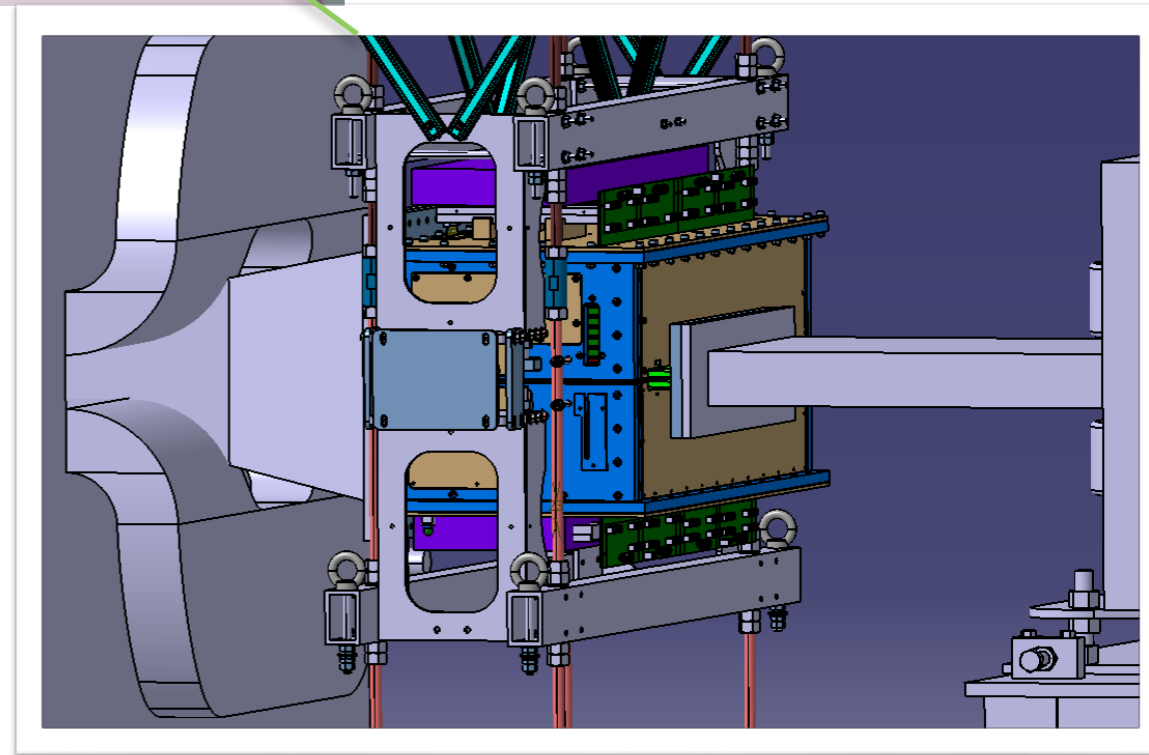
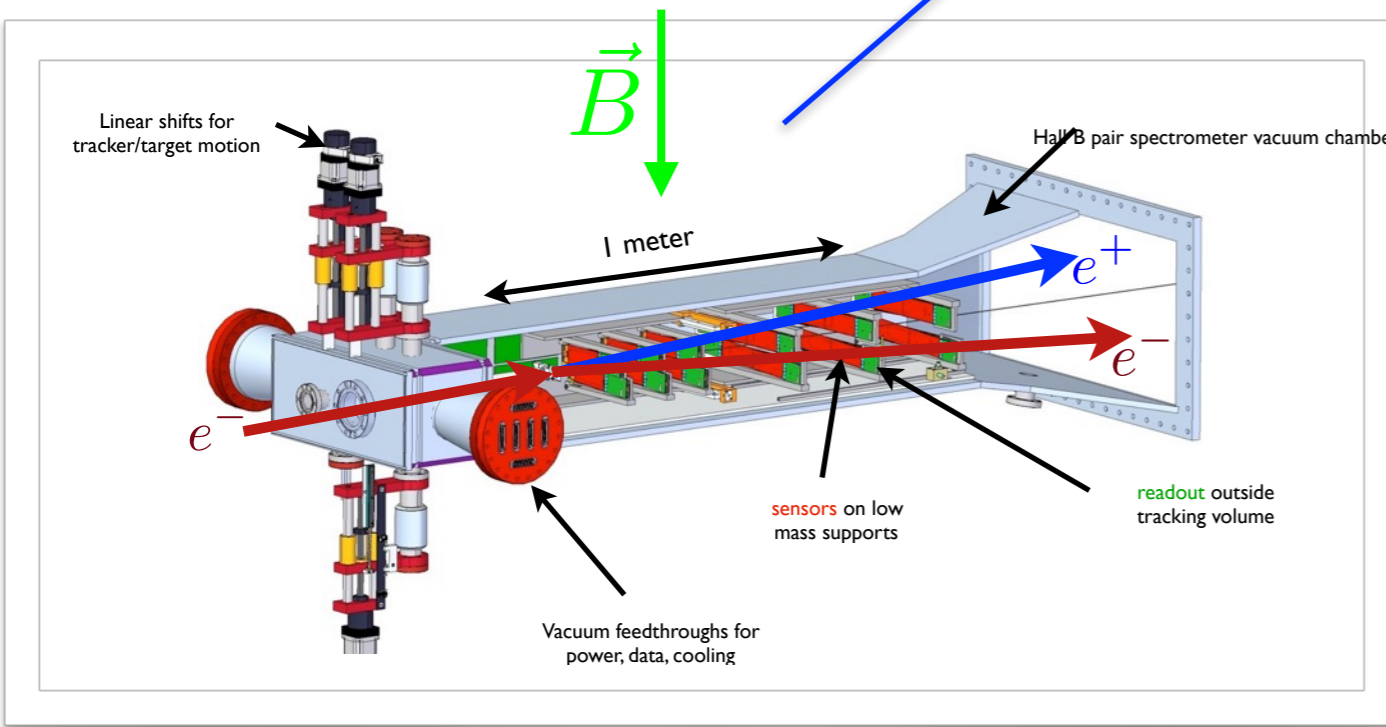

- SVT measures trajectories of electrons to reconstruct e^+e^- mass and vertex position.
 - A PbWO₄ ECal provides trigger with precision timing to reject background.
- Both systems provide coverage only down to 15 mrad above/below beam plane to allow scattered primary beam to pass through middle of detector.

HPS Signal Sensitivity

Large signal, *HUGE* background

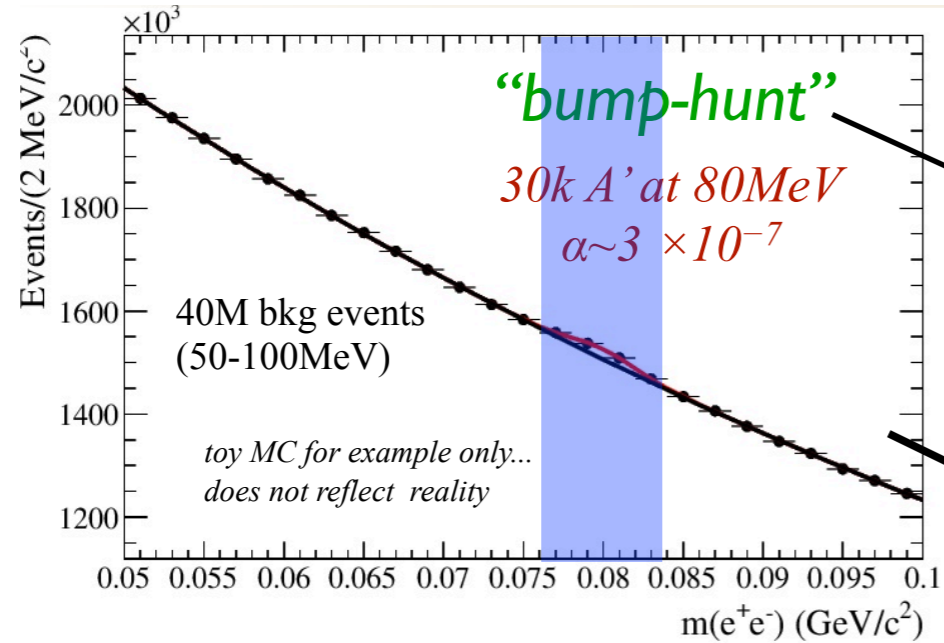

vertexing

Small **signal**, **NO** background

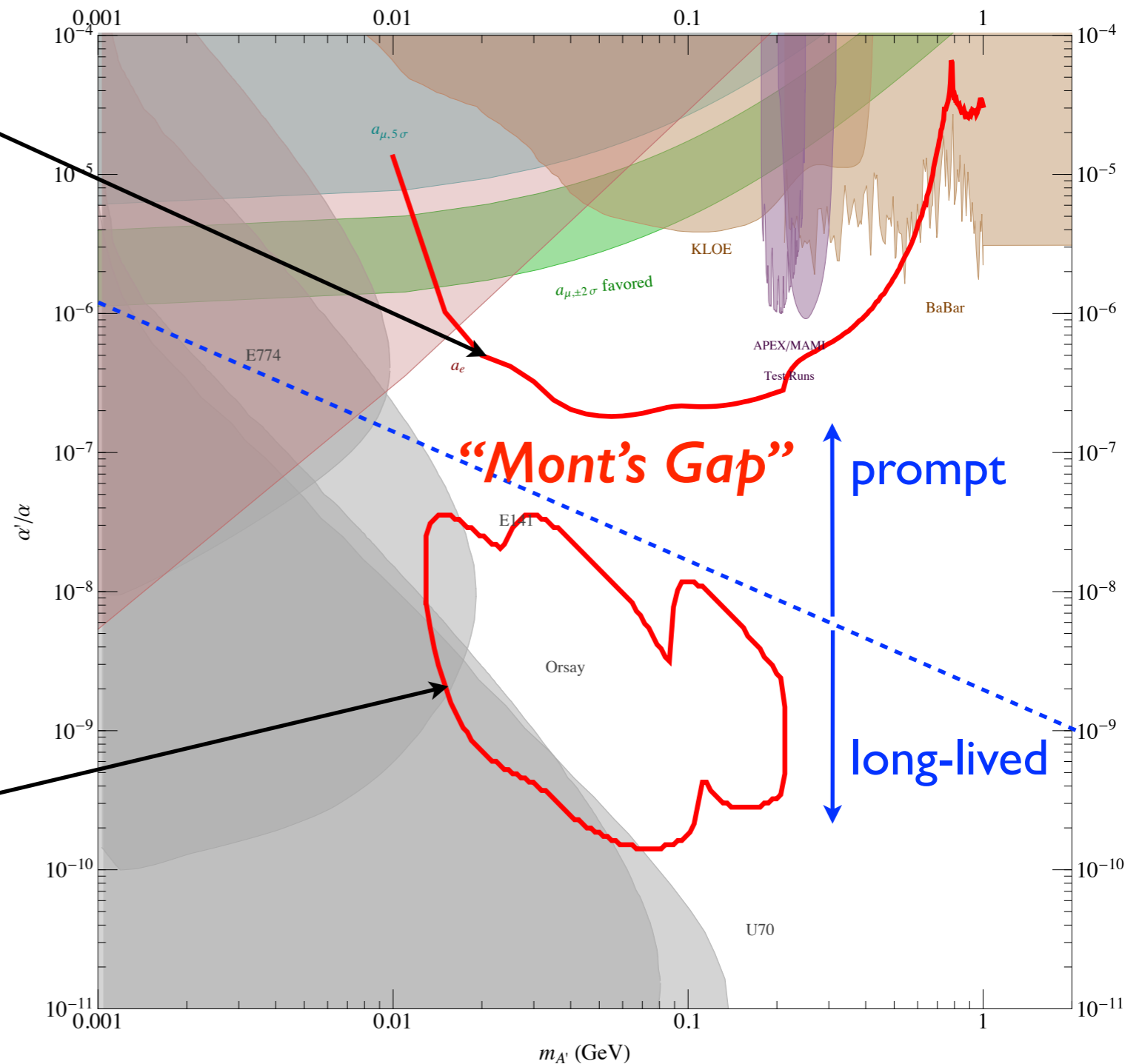
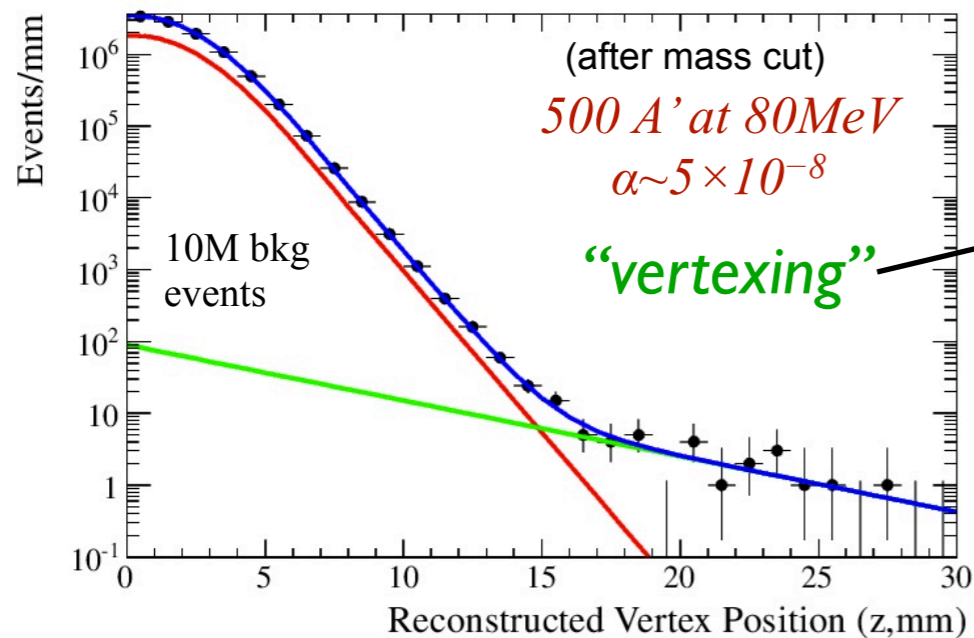

Closing Mont's Gap from Below

Extending the vertex reach to higher couplings is extremely difficult. Need at least a factor of 10 improvement and vertex resolution is dominated by multiple scattering in first layer.

- must bring Layer I closer to target.
 - sensors must be closer to scattered beam to maintain angular acceptance down to 15 mrad.
silicon already 500 μm from center of the beam!
 - occupancy, radiation dose increase as $1/r^2$ from target:
peak occupancies are already >1 MHz/mm² with radiation doses that limit detector lifetime.
- must reduce material in Layer I.
 - Fast, high-occupancy, radiation tolerant silicon detectors have large material budgets:
current material budget is already very aggressive at 0.7% X_0 / 3-d measurement.

Nonetheless... we are looking into it (but that's a different talk ...)

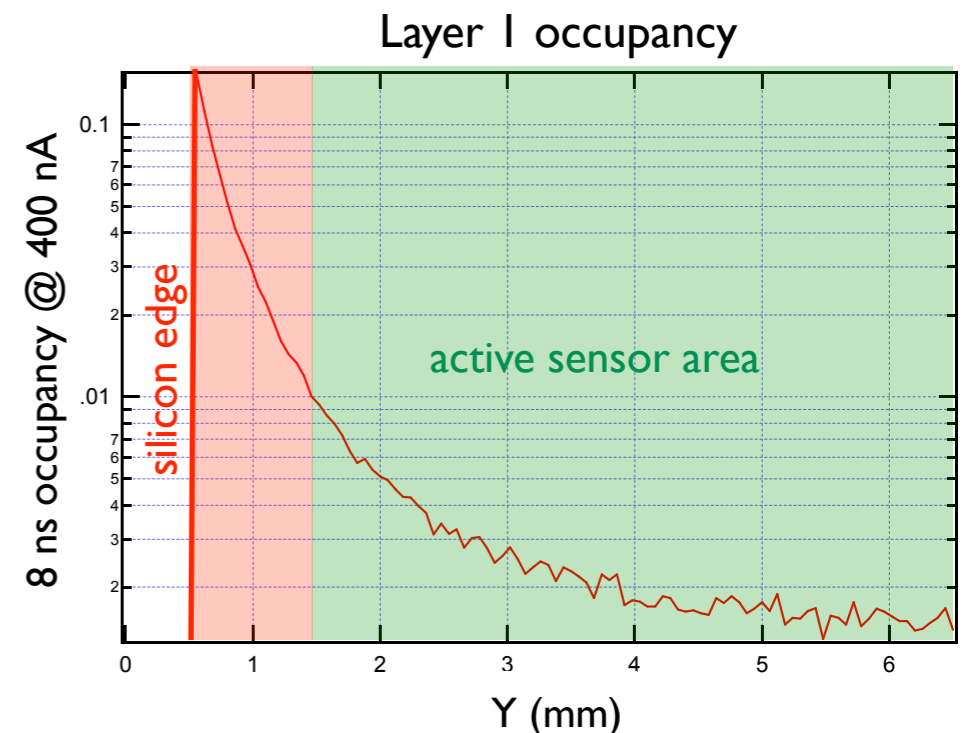
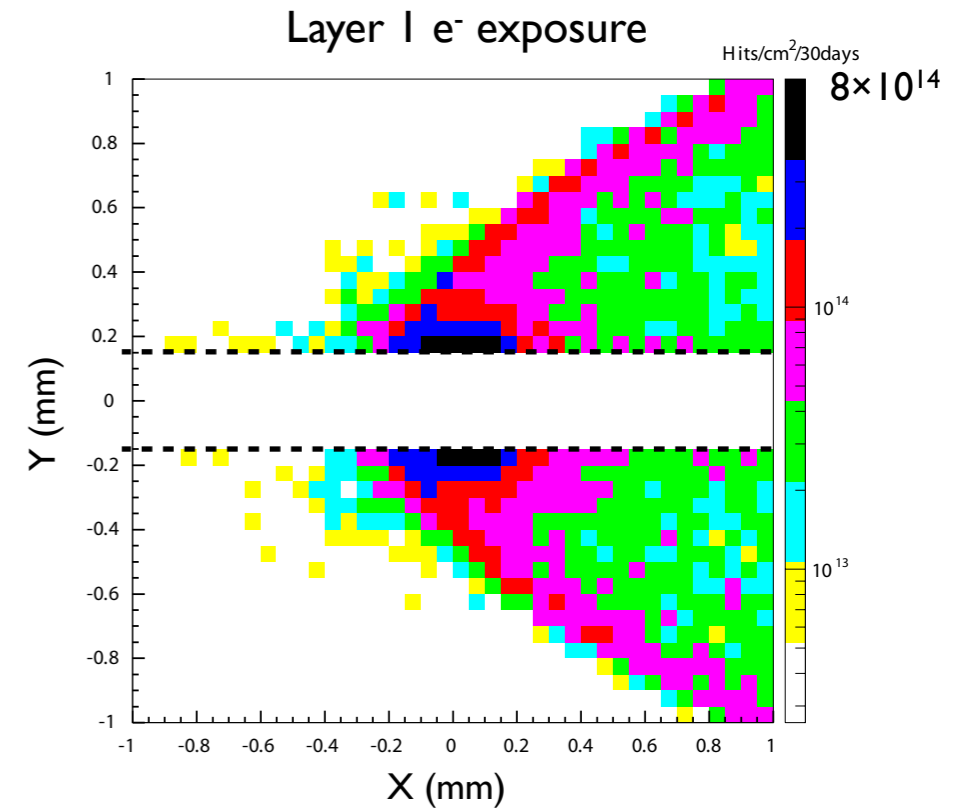

Closing Mont's Gap from Above

Extending bump-hunt reach to lower couplings is much simpler, at least in principle: collect much more data!

- Running time
 - Beam intensity
 - Target thickness
- ➔ Need 2-3 orders of magnitude more data to convincingly close the gap: so it *appears* that a big factor needs to come from luminosity.

Look to JLab APEX experiment for inspiration. APEX...

- generates enormous luminosity with high currents ($>10 \mu\text{A}$) and thick targets ($>1\% X_0$).
- spreads out particles in large two-armed spectrometer
 - reduces occupancies to acceptable levels for slower detectors.
 - provides excellent mass resolution.
- Despite tiny acceptance, APEX develops competitive reach at selected masses with relatively short running times.

Can we apply these concepts to a detector using HPS technologies?

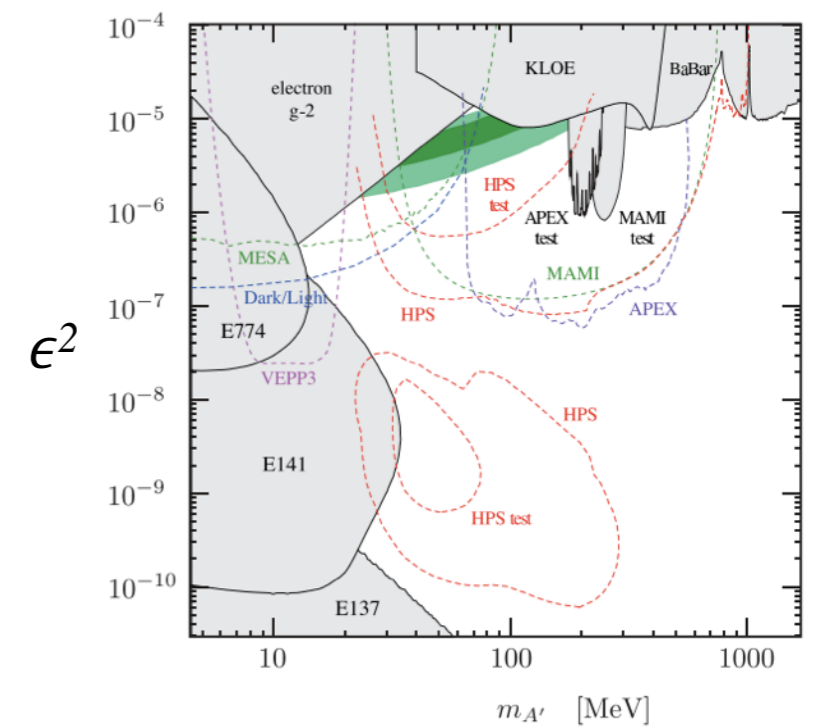
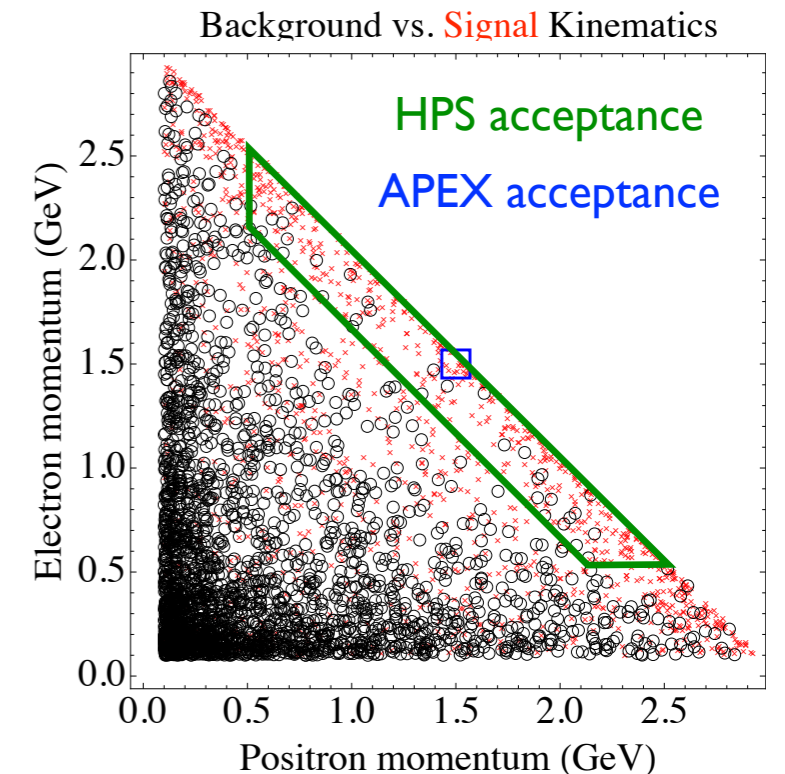
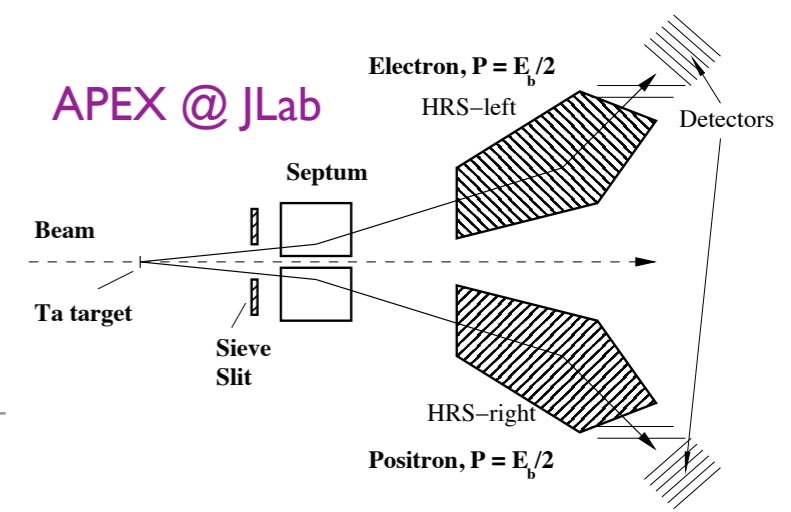

SuperHPS Mass Resolution

Assume:

- Same sensors as current SVT
- Same material budget as current SVT
- Same magnet as current SVT
- Silicon outside B-field
- Ability to constrain to target
(vertexing is possible but requires silicon inside field or an additional magnet.)

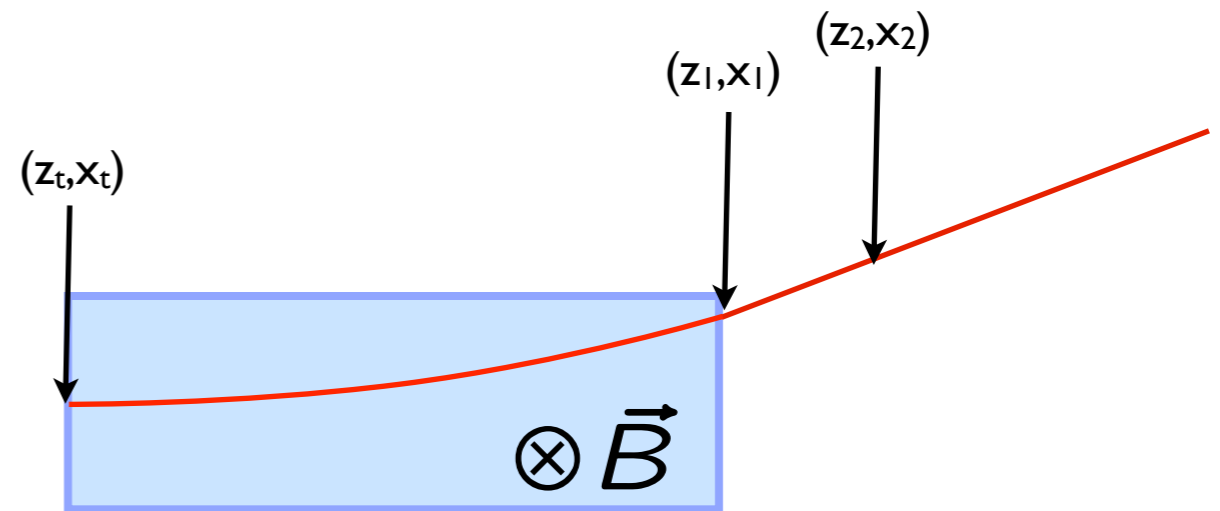

Toy model of track reconstruction at $E_{beam}=6.6$ GeV gives:

$$\textcircled{a} \quad |p| = 1.3 \text{ GeV}$$

$$\frac{\sigma_p}{p} = 0.4\%$$

$$\frac{\sigma_\phi}{\phi} = 0.25 \text{ mrad}$$

$$\textcircled{a} \quad |p| = 3.3 \text{ GeV}$$

$$\frac{\sigma_p}{p} = 0.3\%$$

$$\frac{\sigma_\phi}{\phi} = 0.55 \text{ mrad}$$

These are much better than HPS resolutions @ 6.6 GeV

SuperHPS Dead Zone

Dead zone can be much smaller even at extremely high luminosities.

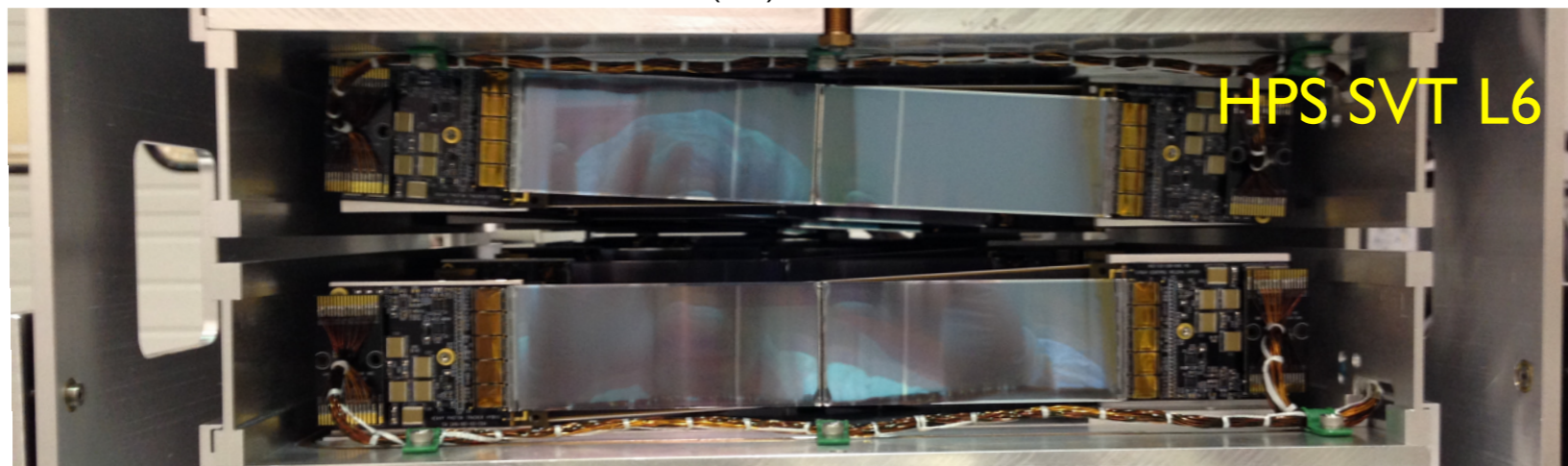
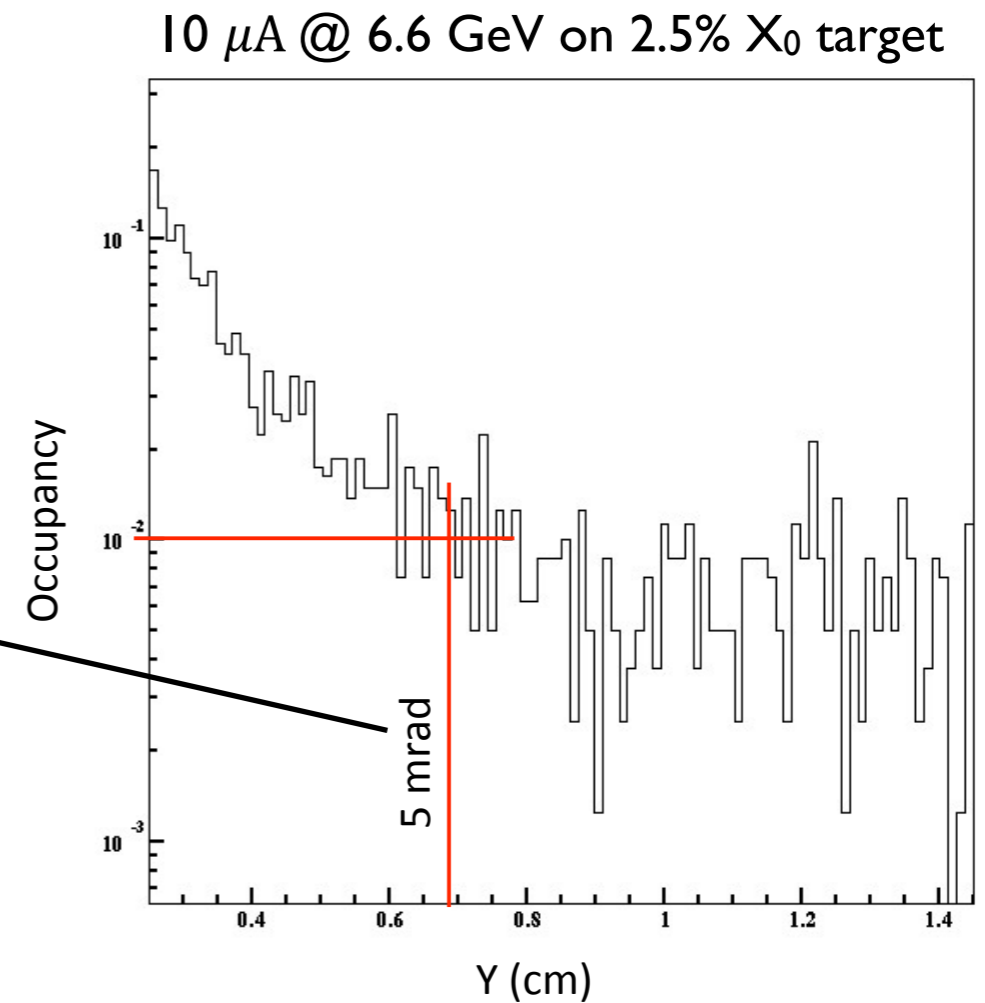
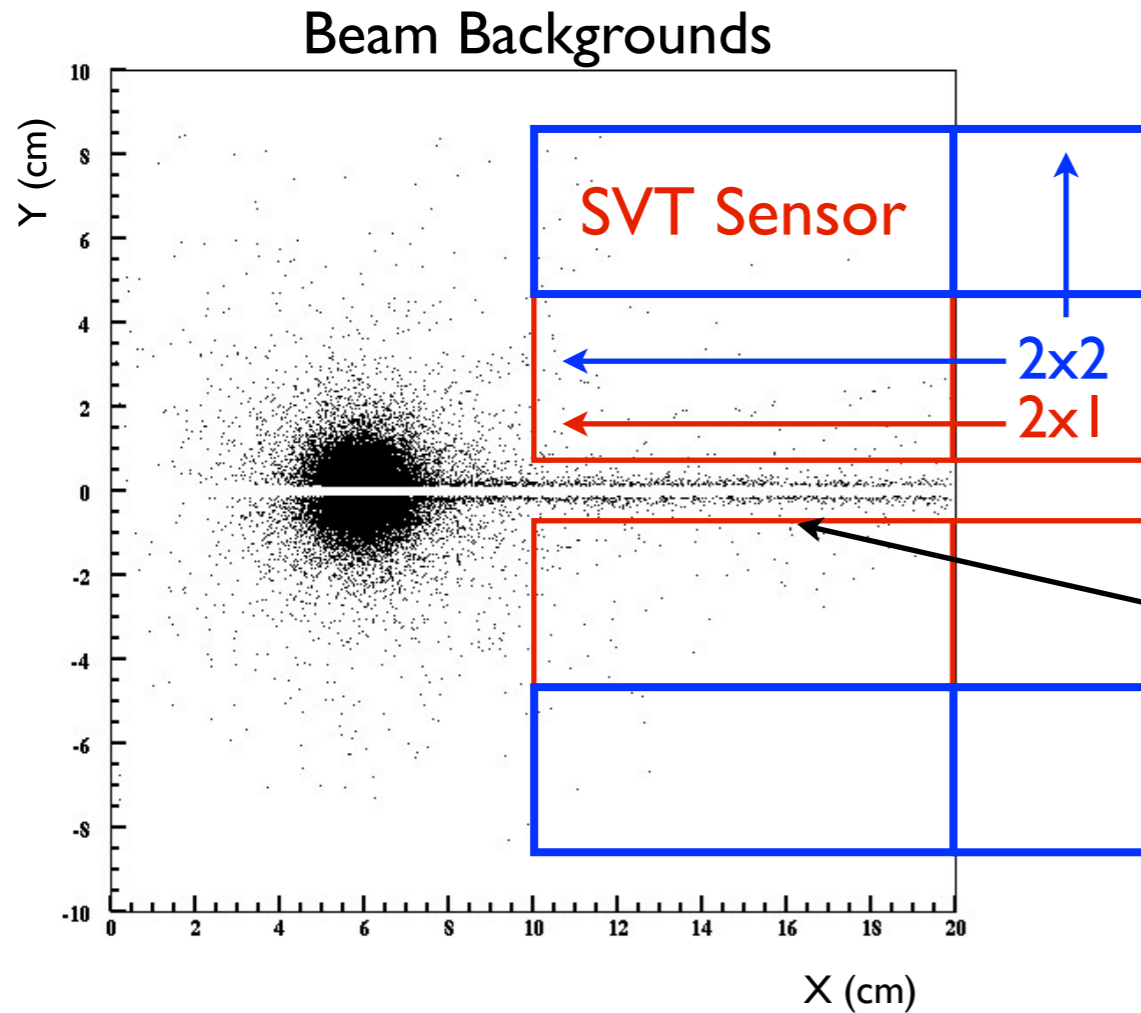

Acceptance

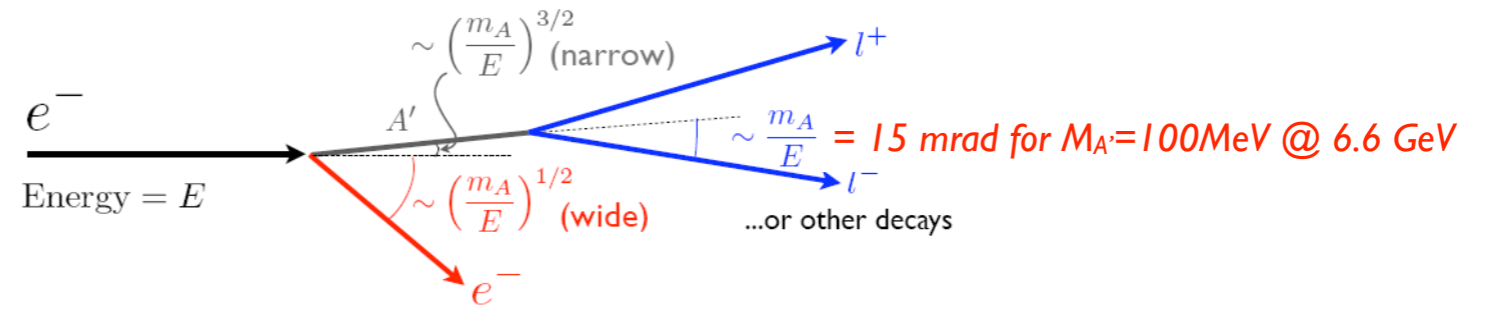

HPS: acceptance so “squeezed” by dead zone it almost doesn’t work!

SuperHPS @ 6.6 GeV

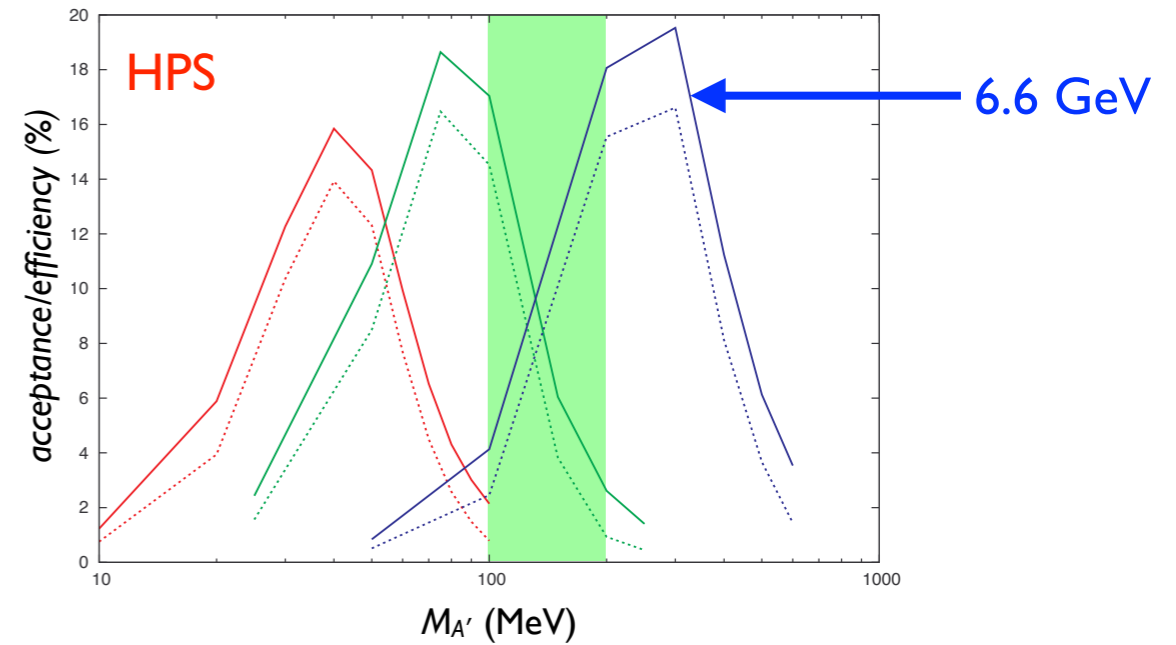
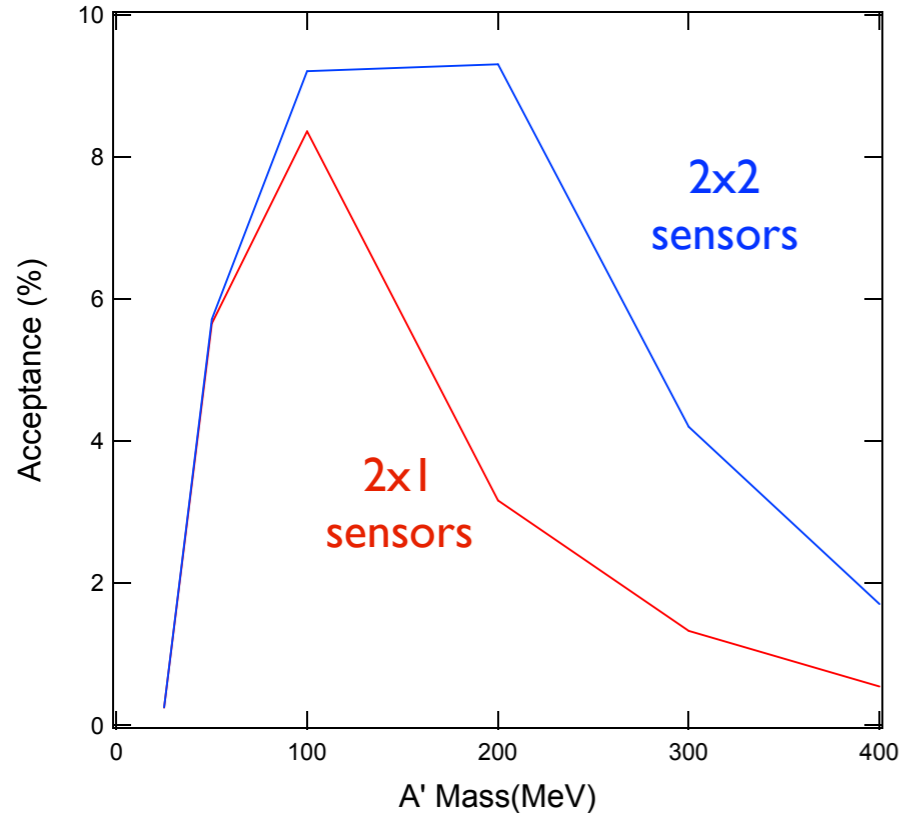

- Acceptance at high mass obviously smaller than HPS.
- Acceptance at low mass is much higher ($\sim 10\times$ at $M_{A'}=50 \text{ MeV}$) due to smaller dead zone.

➔ A very big advantage for SuperHPS because cross section rises rapidly at low mass:

$$\frac{d\sigma}{dx} \approx \frac{8 Z^2 \alpha^3 \epsilon^2 x}{m_{A'}^2} \left(1 + \frac{x^2}{3(1-x)}\right) \tilde{\chi}$$

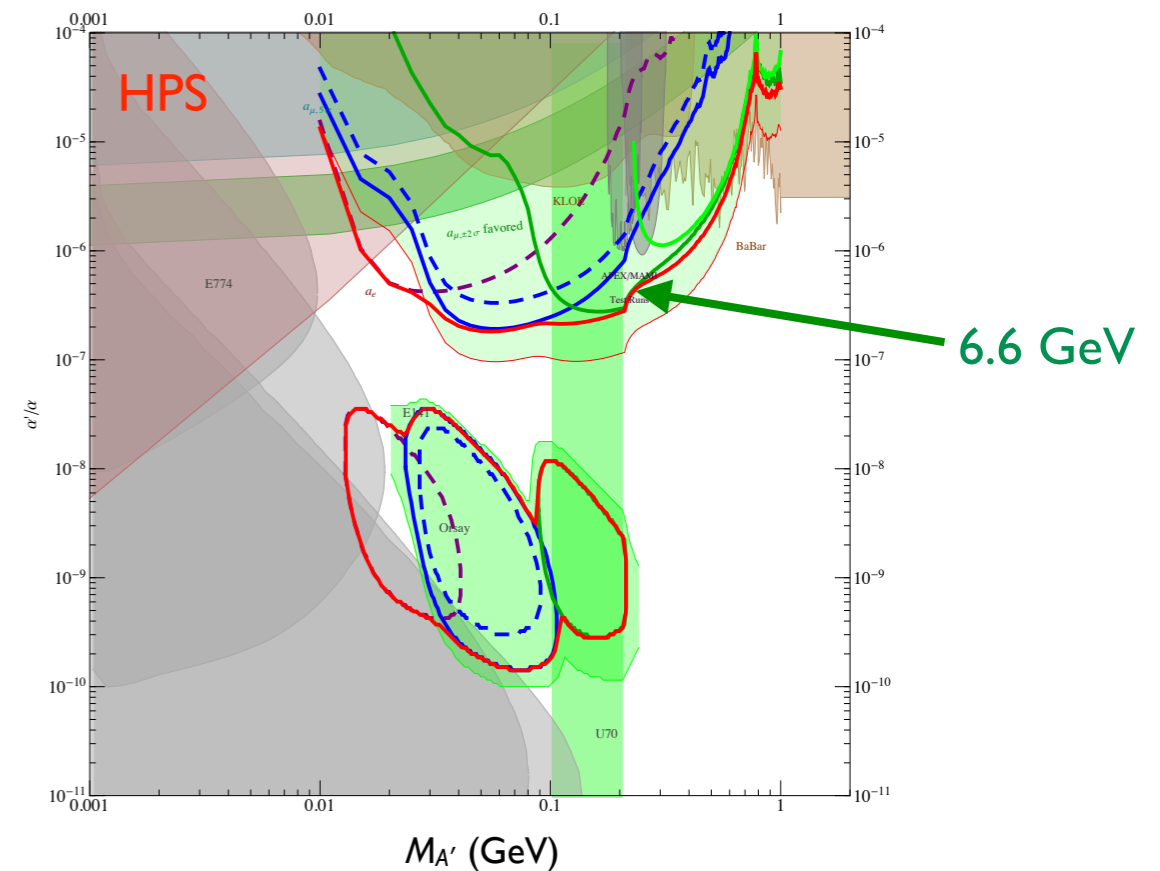

SuperHPS Reach - 6.6 GeV only

15 days a 10 μA w/ 2.5% X_0 target

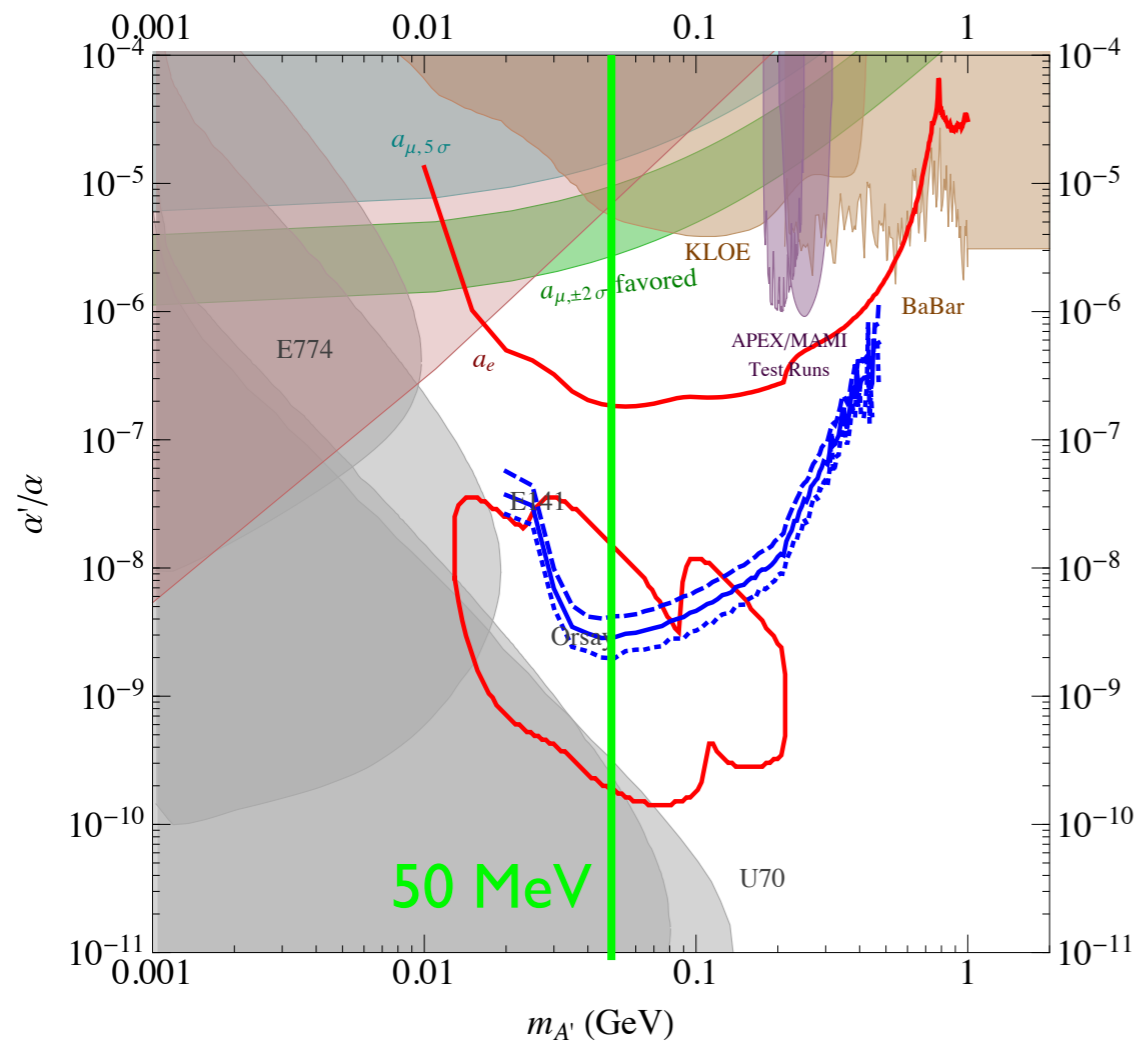

15 days a 450 nA w/ 0.25% X_0 target

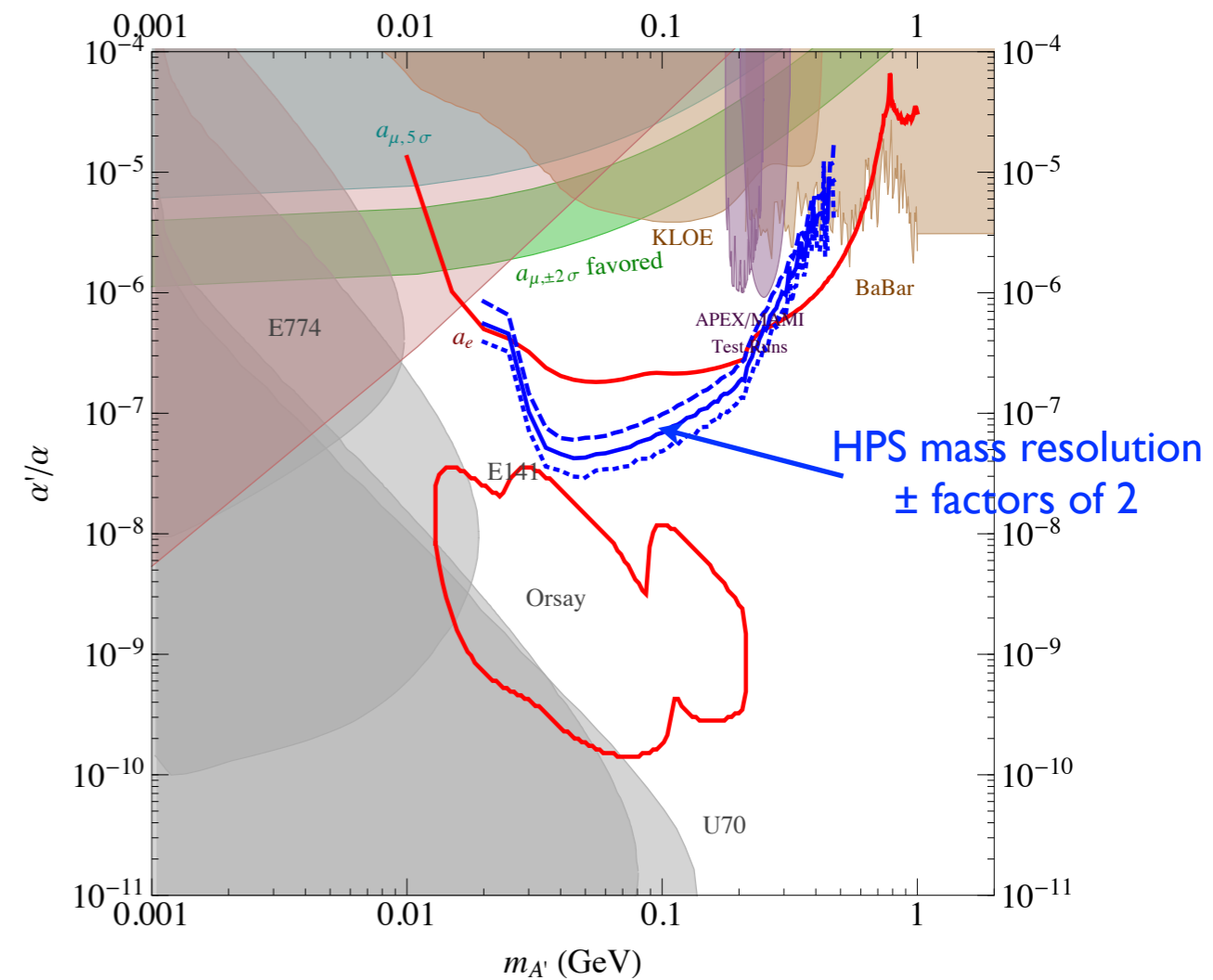

This concept could close "Mont's Gap", even with HPS-like beam currents.

N.B. Without vertexing, mass resolution becomes degraded for long A' decay lengths (i.e. in overlap with HPS vertex reach).

Optimizing for Lower Currents @ LCLS-II

- Assume $1\mu\text{A}$ is possible for 150 day run on 2.5% X_0 target.
(222 \times as much data as 15 day run at 450 nA on 0.25% X_0 target.)
- Run at 4 GeV beam energy (acceptance moves down by 40% in mass).
- $1\mu\text{A}$ current allows even smaller dead zone (acceptance extends downward 60% further in mass.)

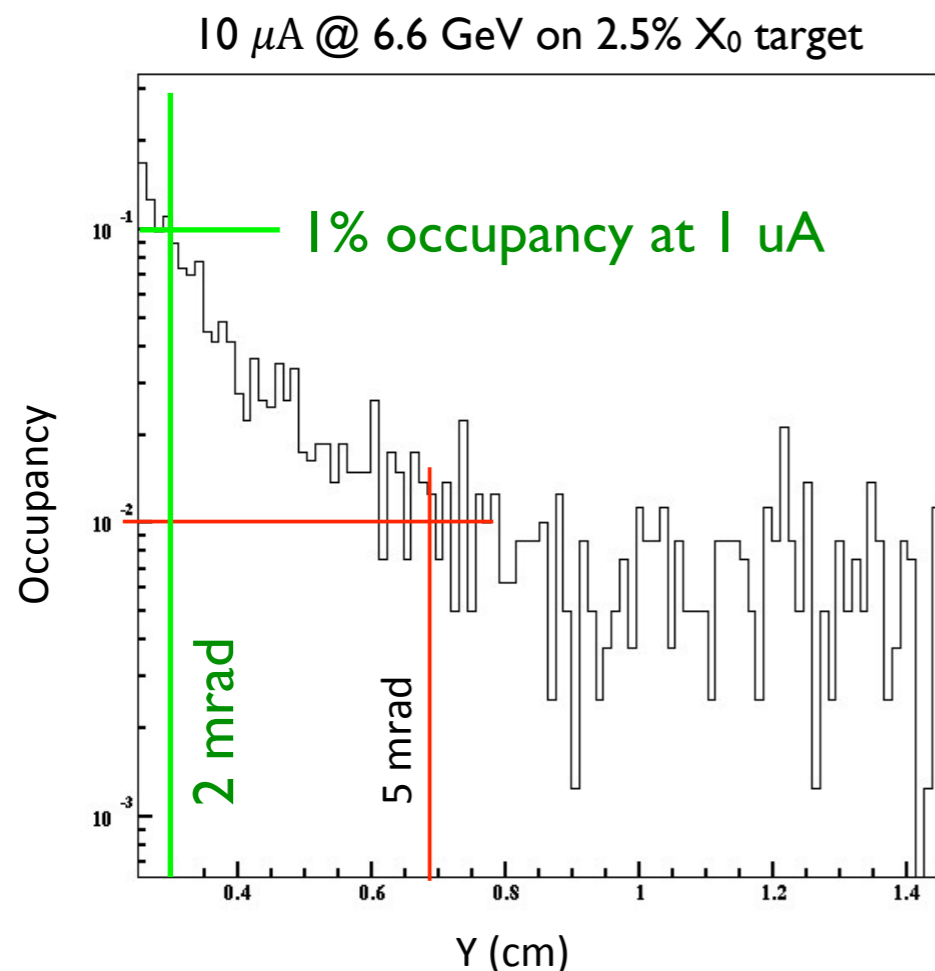

150 days a 1 uA w/ 2.5% X_0 target, 2 mrad dead zone

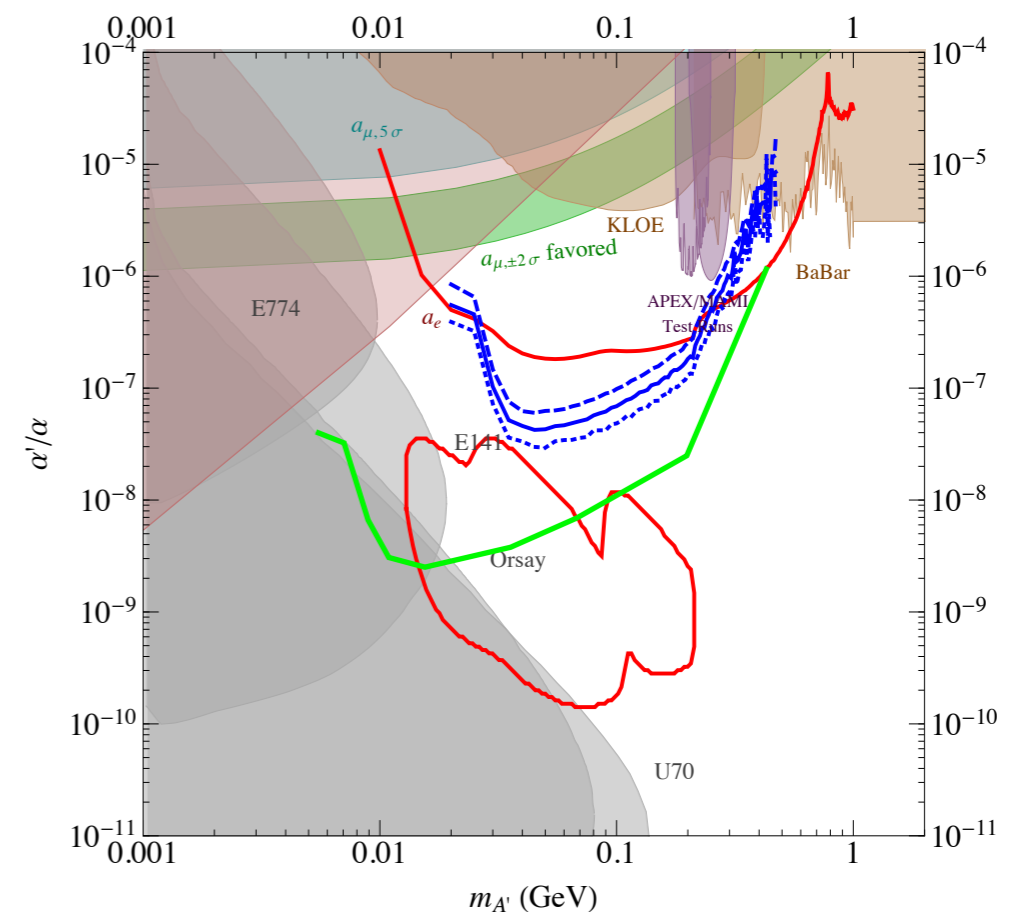

Detector Requirements

Space and Beamline:

- Roughly 4 m × 4 m floor space.
- Dipole magnet with bore large enough to pass A' daughters within full SVT acceptance. An I8D36 @ 1 T would be fine at 4 GeV beam energy.
- Transport of scattered beam in vacuum.
 - Positron tracker doesn't need vacuum *if* thin vacuum window OK for tracking.
 - Same *may* be true for electron tracker.

Tracking:

- 20-24 HPS double-ended modules (5-6 layers) on positron side. (20 built for HPS)
- Electron side is more difficult due to **scattered beam at inner ends of modules**. A new module design, possibly even new sensors, could be required.

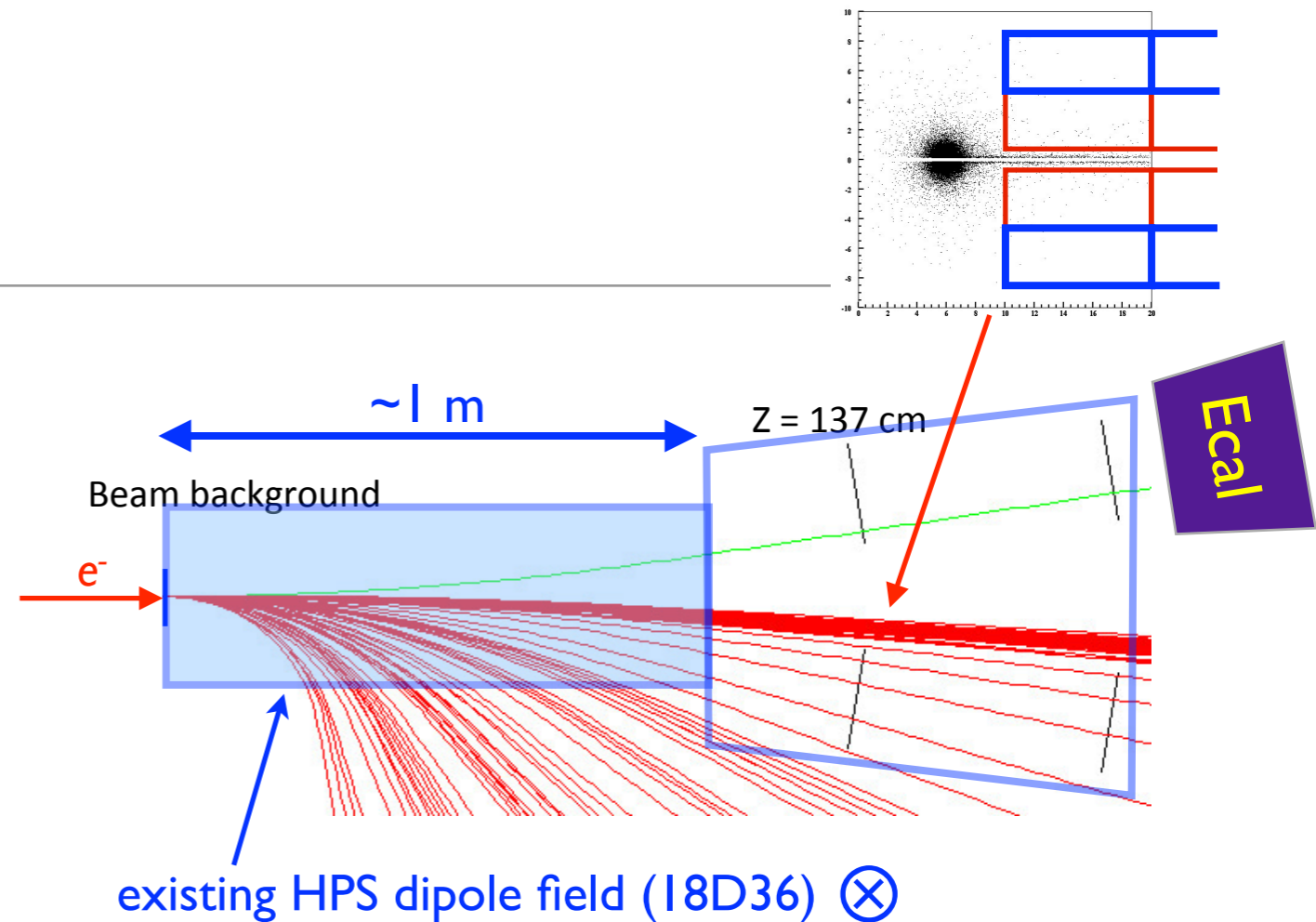

Trigger/DAQ:

- In HPS, ECal occupancy on positron side is mostly scattered electrons. Here, only real tridents should produce hits in ECal on the positron side. Therefore, likely that only the positron side needs to be instrumented for a trigger.
- Based upon HPS trident+pion rates (~ 3 kHz), rates for 1 μ A on 2.5 X_0 W target probably *just* fit within HPS trigger budget so that current DAQ works for both ECal and SVT.

Super HPS Beam Requirements

Time structure / bunch charge

- Selecting against backgrounds requires small bunches with high repetition rate. Studies assume HPS time resolution which results in 8 ns window for coincident hits. Therefore, no 8 ns time window should have significantly larger bunch charge than $1 \mu\text{A} \times 8 \text{ ns}$.

Beam size / stability

- Angular resolutions in tracker imply that IP for an event should be known to approximately $0.25 \text{ mrad} \times 1.37 \text{ m} = 400 \mu\text{m}$ to achieve best mass resolution.

Beam instrumentation

- Need a serious beam dump and radiation shielding.
- Hazard to detector is much lower than HPS: beam diagnostics and safeties can be relatively simple.

Super(Duper) HPS?

- Performance is so strong at low mass, that unique reach is maximized by running at higher beam energies.
- Operating at 11 GeV at JLab is one obvious possibility.
- Maximizing reach at high mass begs for muon and pion triggers: these are relatively simple to envision if positive-side-only triggers work.
- Low-Z targets would further enhance high-mass reach.

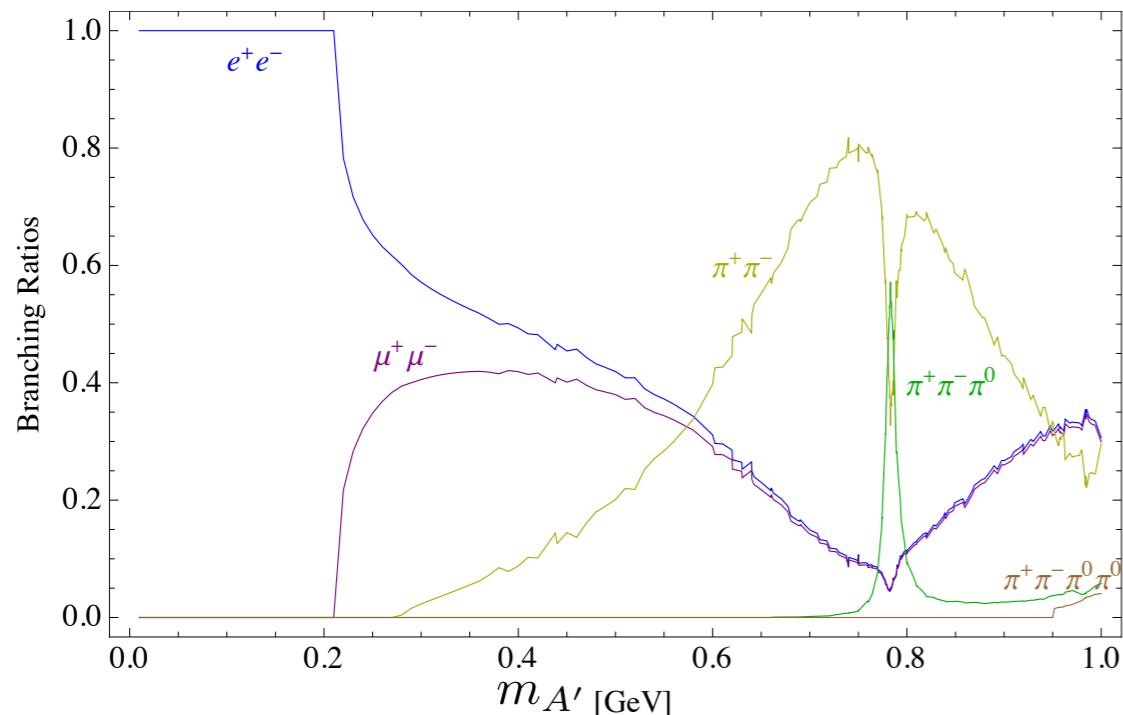
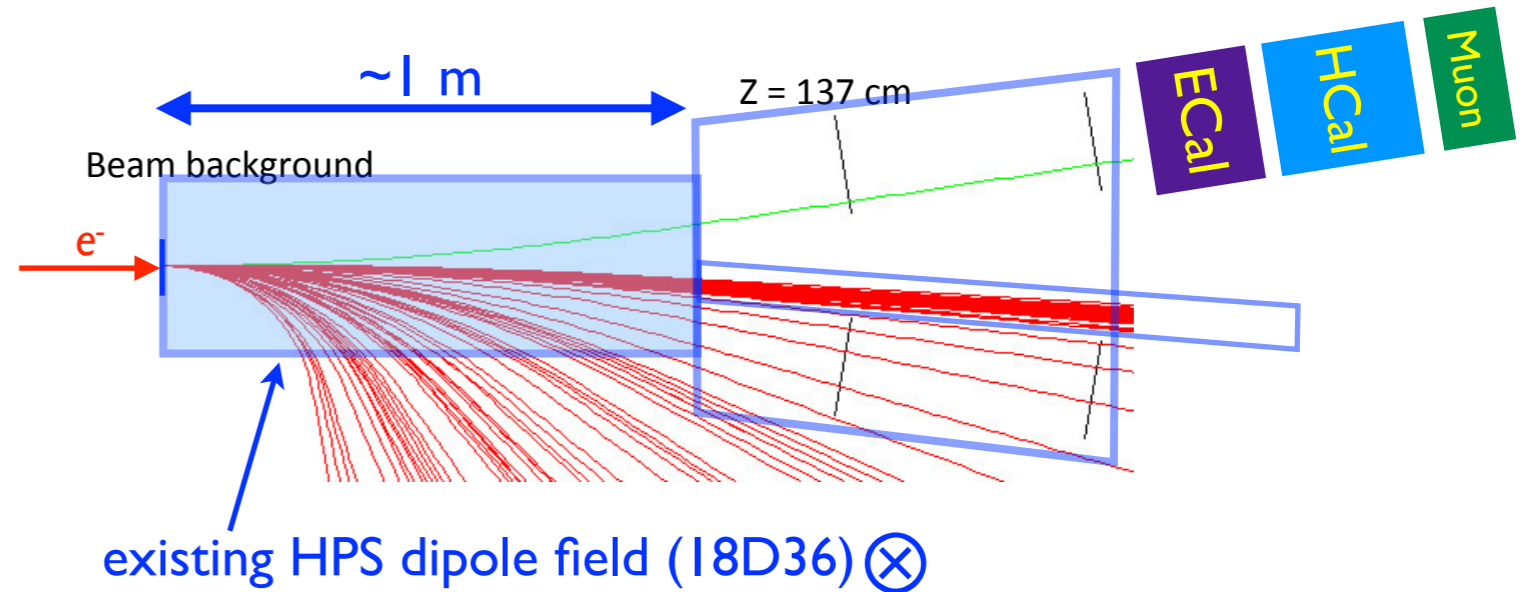

150 days at 1 μA w/ 2.5% X_0 target, $E_{\text{beam}} = 11 \text{ GeV}$

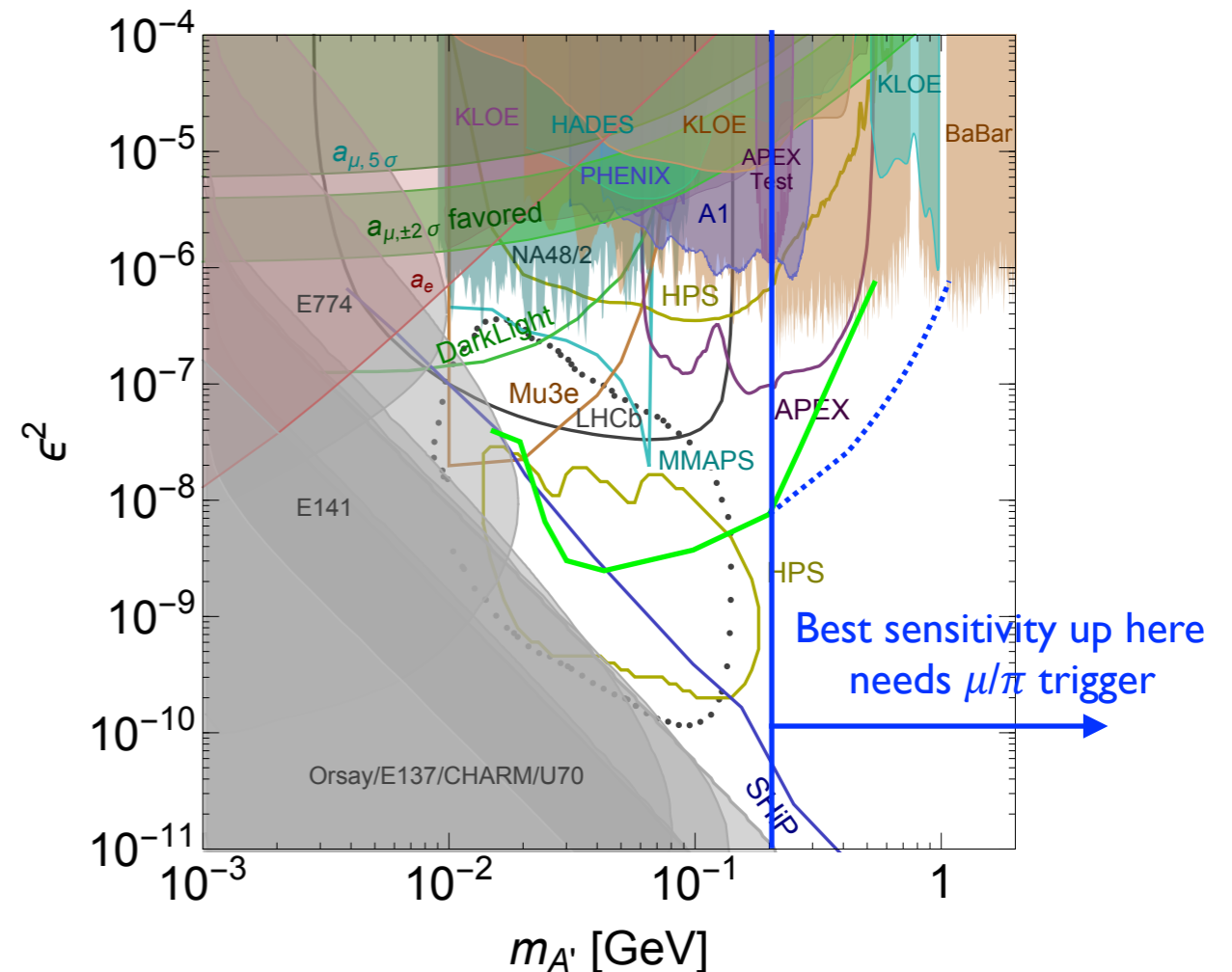

Conclusions

- Using technologies developed for HPS, a two-arm spectrometer optimized for dark photon detection can close “Mont’s Gap”.
- Such a detector could be deployed and operated at SLAC with LCLS-II drive beam if:
 - well-leveled, low-bunch-charge electron beam can be delivered at intensities approaching $1 \mu\text{A}$ with good spot size and stability.
 - space can be found to install and operate the detector for at least a year.
- Starting with infrastructure already in place at JLab, costs could be similar to that of HPS. Costs at SLAC would likely be considerably higher.
- Addition of muon and pion triggers is well motivated for operation at higher beam energies and likely much simpler than for HPS.