

Technology & Innovation Directorate (TIR) Advanced Instrumentation for Research (AIR) Division

All-Hands Meeting

Gunther Haller – Division Director
Kent Irwin – Division Chief Scientist
February 18, 2015



TID -AIR Division



SLAC strategic plan published end of last year calls out four SLAC competencies & strengths

- Lasers, Accelerators, Optics, “Detectors & Instrumentation”

The reason you are here today is that you are part of one of the core competencies of the lab

Vision is to use and advance our core competency in advanced instrumentation

- Innovate and develop cutting edge technologies mainly for
 - accelerators
 - elementary particle physics and particle astro physics & cosmology science application
 - photon science application
 - detector systems and instrumentation for all kind of applications in other fields (i.e. medical, etc)
- And to
 - develop a broader sponsor base across other federal agencies, Stanford main campus, and other labs (sponsored research and WFO)
 - be an innovative engine for SLAC and move the lab in new directions

Technology & Innovation Directorate – Organizational Chart

Technology Innovation Directorate

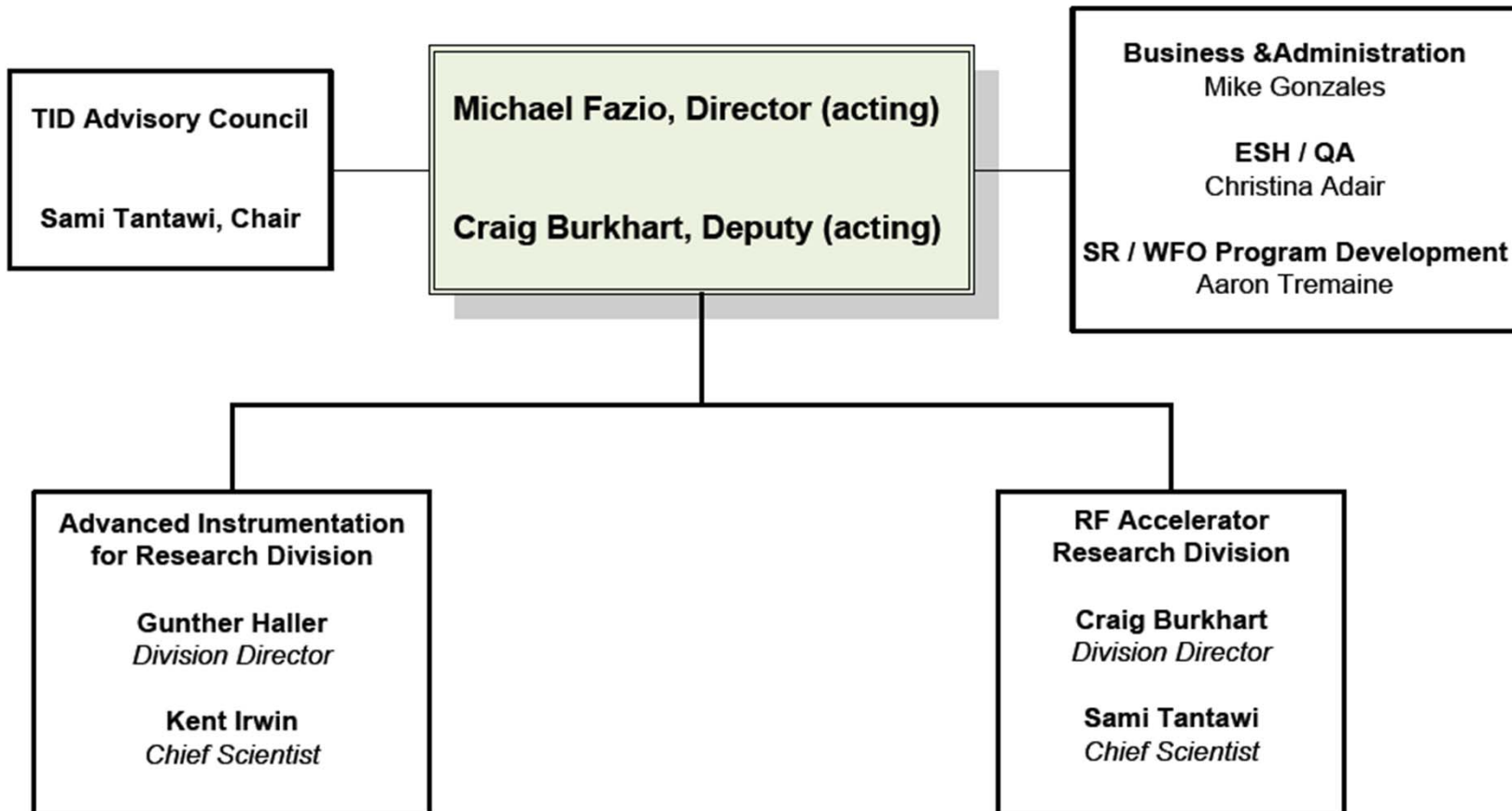

AIR Division – Organizational Chart



Our HR contact:
A. Moore

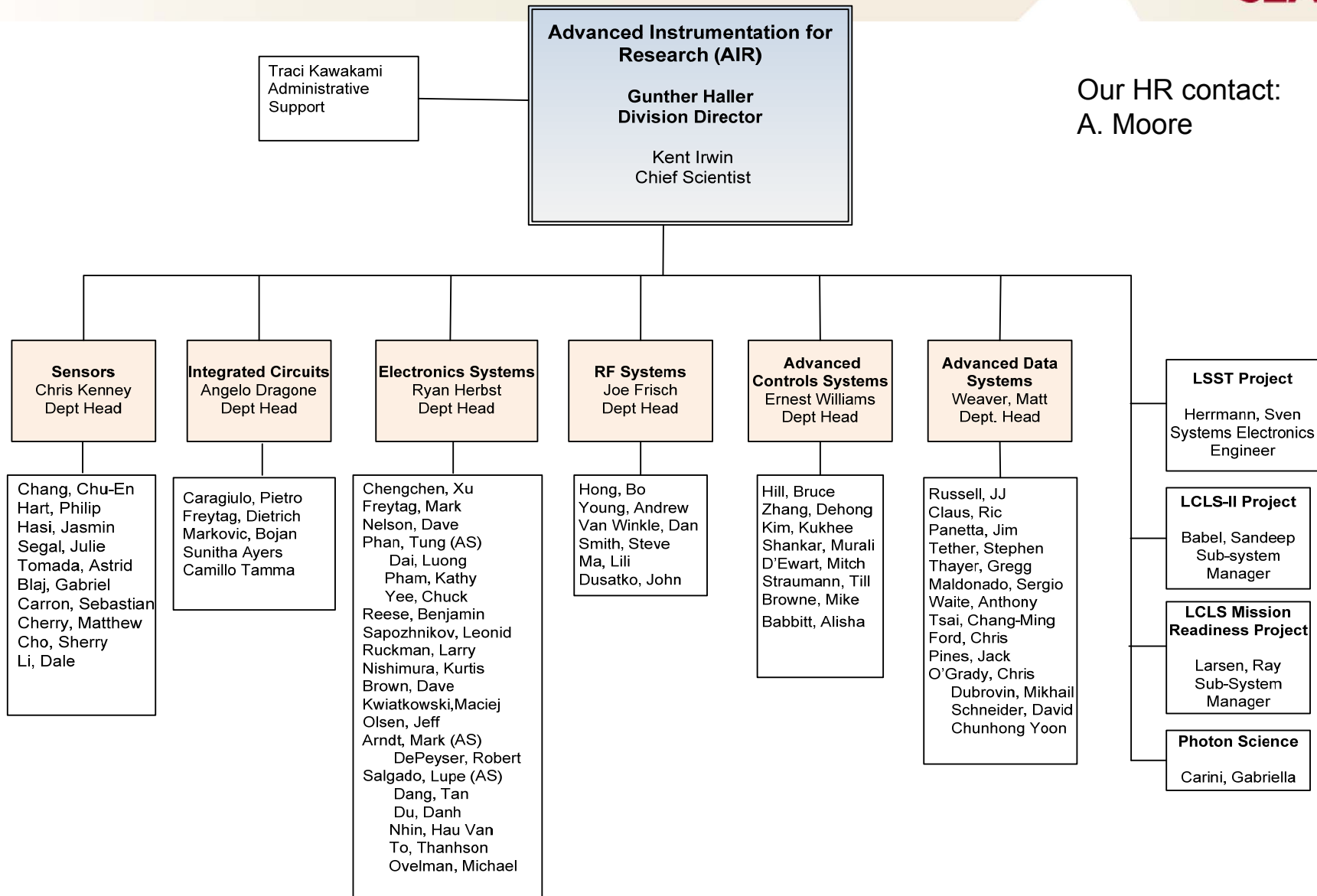

Transition to new Organizational Structure

Time-sheets/SLAC directory

- Should be in place, some issues are being resolved

Accounts

- Use accounts as before (i.e. what you are working on)
- New Science directorate and TID accounting structures are going to be in place later this year

Transition to new Organizational Structure con't

Locations:

- Most in building 84
 - Offices
 - Clean room
 - Assembly lab
 - Several electronics labs
- Engineers also embedded at
 - LCLS experiments (working with teams from LCLS-CDS, Perazzo)
 - Accelerator controls (working with teams from AD-ICD, Carrone)
 - Stanford Nanofabrication Laboratory on main campus
- Some moves expected over the next few months
 - Most stay where they are currently

Transition to new Organizational Structure con't

Interaction/processes of AIR and controls operations is/are already being defined by division directors and department heads

- AIR G. Haller, E. Williams
 - AD-ICD E. Carrone, D. Rogind
 - LCLS-CDS A. Perazzo, D. Flath, J. Thayer
-
- Separate meeting to follow with the controls teams to discuss detailed plan forward

 - Meanwhile work continues as before until informed of changes by division directors
 - Same applies for engineers working on LCLS-II and Mission Readiness controls projects

Some of the current projects (not complete)

Elementary Particle Physics

- Heavy Photon Search Experiment – front-end electronics and data acquisition
- LHC ATLAS – sensors, high-speed transmission and data acquisition
- LBNF – data acquisition
- nEXO - Integrated circuits/electronics in liquid Xenon, data acquisition
- LZ – Electronics for R&D project at SLAC
- ILC-SiD – Detector systems
- Belle-II detector (WFO)

Astrophysics

- FERMI (Gamma Ray Space Telescope) operations
- LSST (SLAC is project office for telescope camera, to be designed and integrated at SLAC, moved to Chile in 2019)
- CMB (Cosmic Microwave Background)

Generic DOE HEP detector R&D

- Sensors, detectors, data acquisition

Some of the current projects

Accelerator Controls Instrumentation development

Photon Experimental Instrumentation development

Other emerging areas

- Medical, neuroscience

AIR Division – Organizational Chart

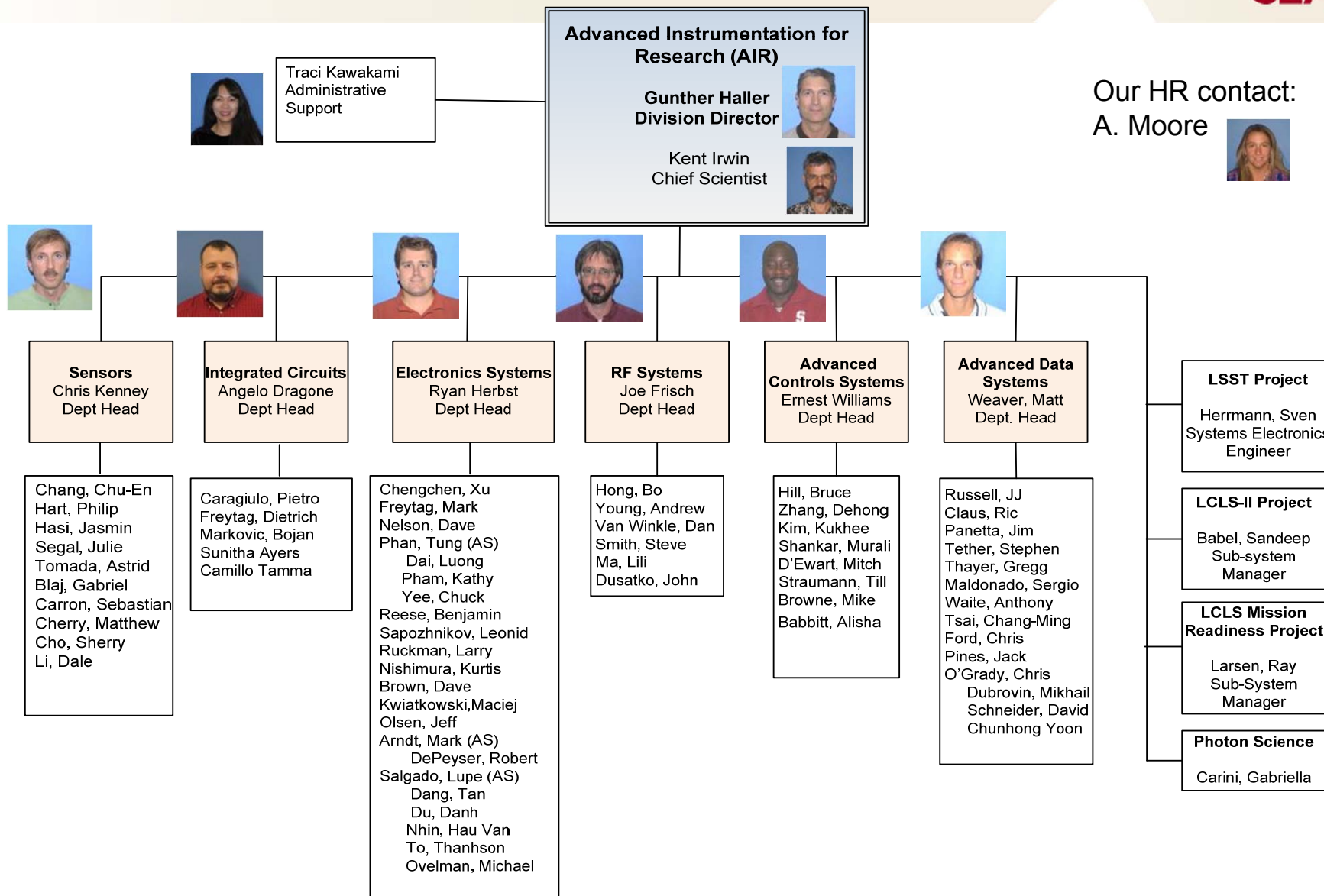

Scope and competencies - Brief presentations

Upcoming: Some intro from the chief scientist and from each department head on the org chart

In addition there are project sub-system leads

- S. Herrmann (LSST deputy chief electronics engineer and guider sub-system electronics lead)
- S. Babel (LCLS-II controls, sub-system lead)
- R. Larsen (LCLS-I Mission Readiness controls, sub-system lead)
- G. Carini (Photon science)

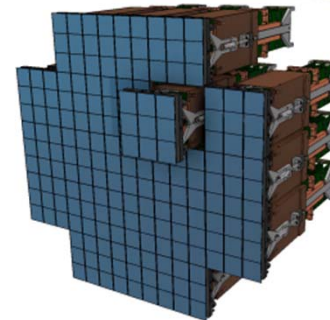
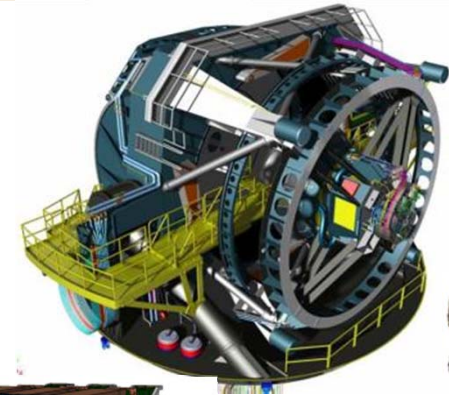

World's largest digital camera for astronomy with 3.2 gigapixels!

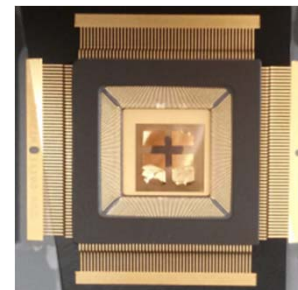

Diamond detector: first prototype with graphene contacts.

Technology & Innovation Directorate (TIR) Advanced Instrumentation for Research (AIR) Division

All-Hands Meeting

Kent Irwin – Division Chief Scientist
February 18, 2015



Division chief scientist role – as I see it



- Advocate for AIR/TID with DOE & SLAC
- Help maintain connections to science directorate, both for scientific impact and support.
- Help with SLAC infrastructure investments relevant to AIR (equipment, clean rooms, etc.)
- Help with finding LDRD & WFO funding.
- Help with planning strategic directions.
- Help with improving connections to campus.

Affiliations at SLAC and on campus (physics, photon science, and PPA faculty) can be useful in making the above connections.

I have a lot to learn about the work in AIR – let me know how I can help you.

Some areas of personal research interest: CMB and x-ray spectroscopy

Strong collaboration in sensor department with Sherry Cho and Dale Li

Emerging DOE program: CMB stage-4

- Target CD-0 in 2017
- Legacy in CMB science: all of the CMB experiments currently in the field use our sensors / superconducting electronics

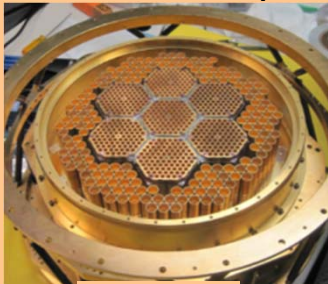

SPTpol



ACTpol

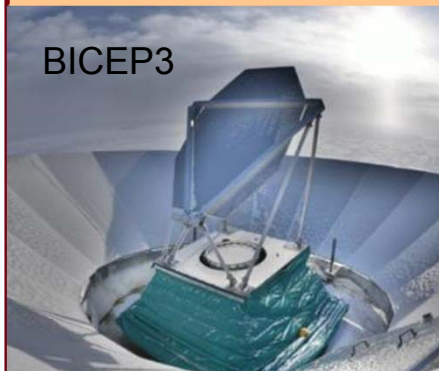

BICEP3



High-efficiency superconducting x-ray spectrometers

- LDRD for SSRL spectrometer
- BES funding to develop LCLS-II sensor technology

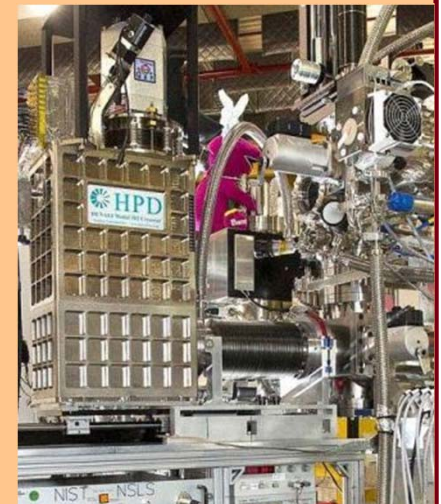

Spectrometer at NSLS

Example: spectroscopy of threat materials

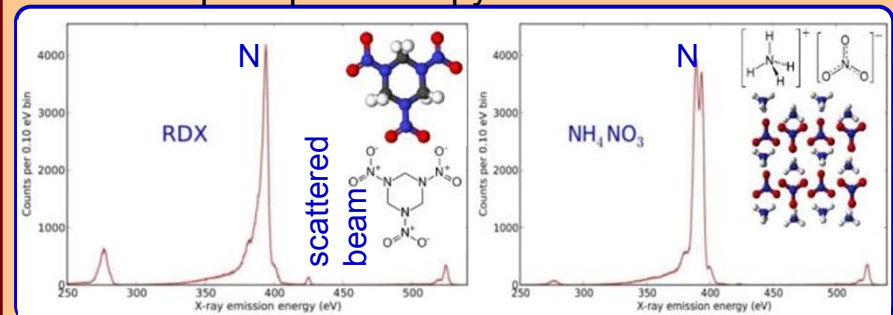

Technology & Innovation Directorate (TIR) Advanced Instrumentation for Research (AIR) Division

All-Hands Meeting

Sensors Department

Chris Kenney – Department Head

February 18, 2015



AIR-Sensors Competencies

SLAC

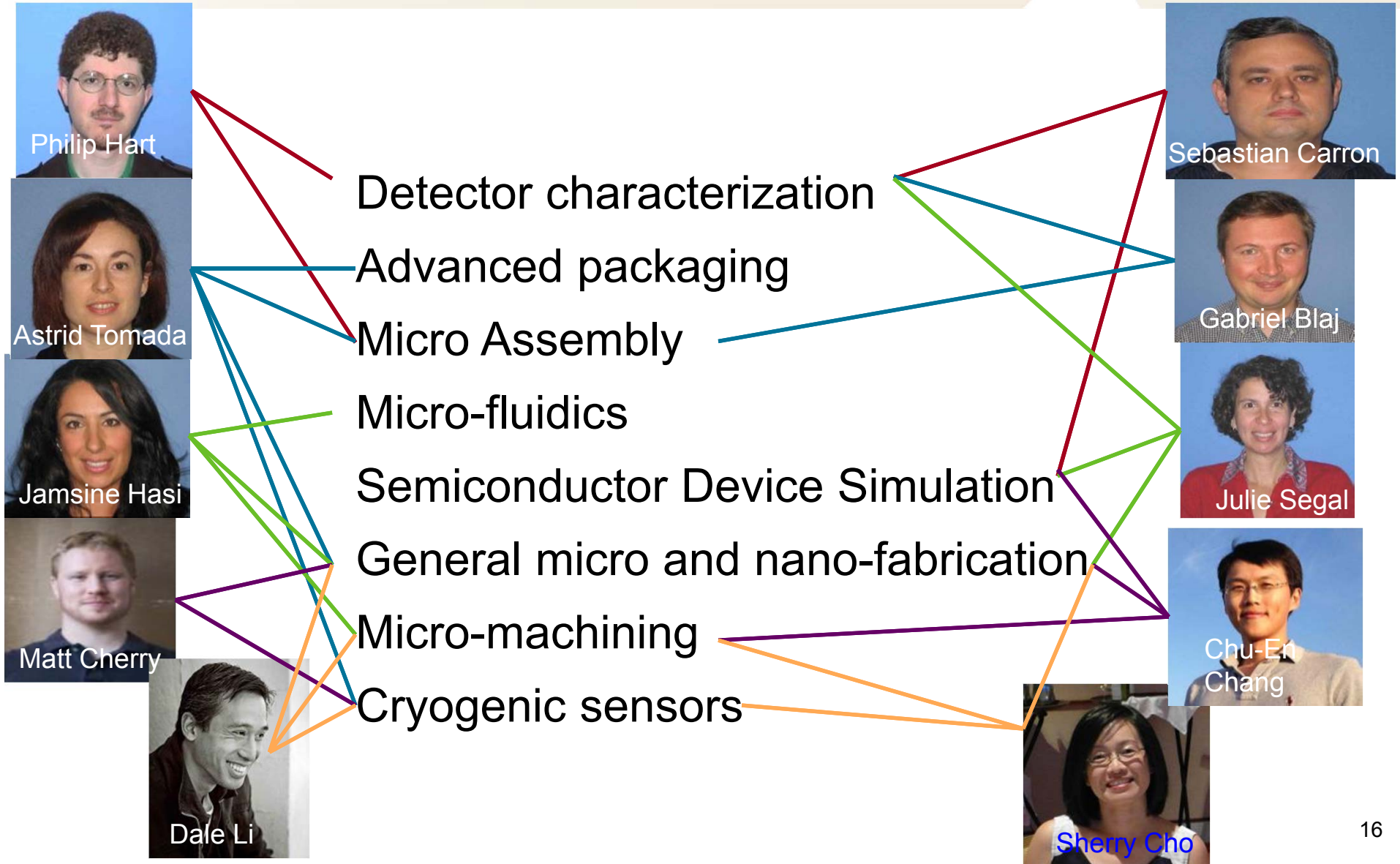

AIR-Sensors What we work on

- ATLAS Sensors
- ATLAS CMOS sensors
- Fast beam monitors (KEK WFO)
- Bump bonding (CERN WFO)
- Neuroscience
- CDMS
- CMB

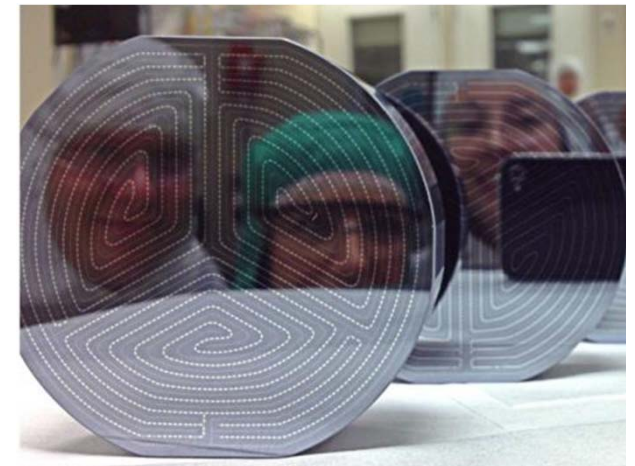
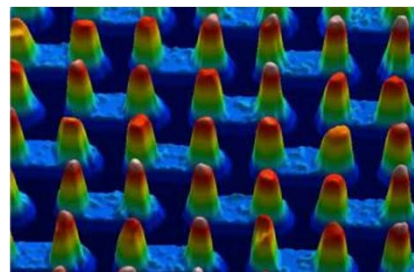
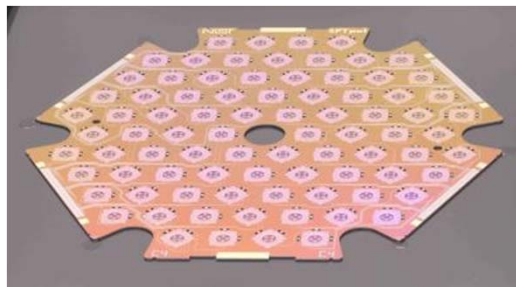
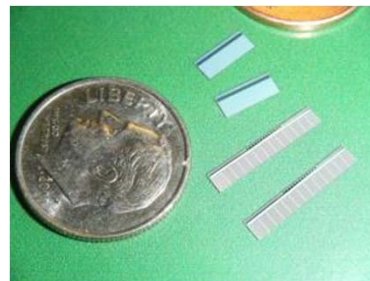
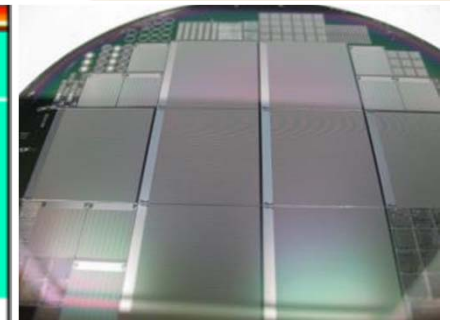
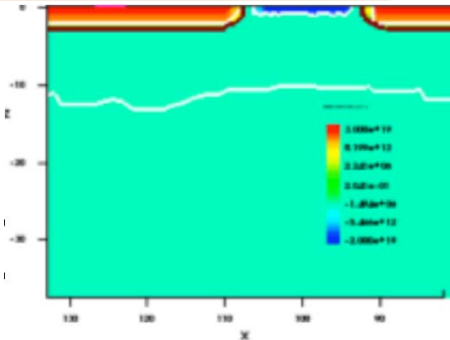

What we work on

AIR-Sensors ++++ ASIC, Electronics, DAQ, Mechanical....

SLAC

- Along with rest of AIR!
- LCLS Detectors
- LCLS II detectors
- Soft x-ray
- High frame rate
- vfCCD, CMOS, ePix-HR, TES, Hard X-ray Systems

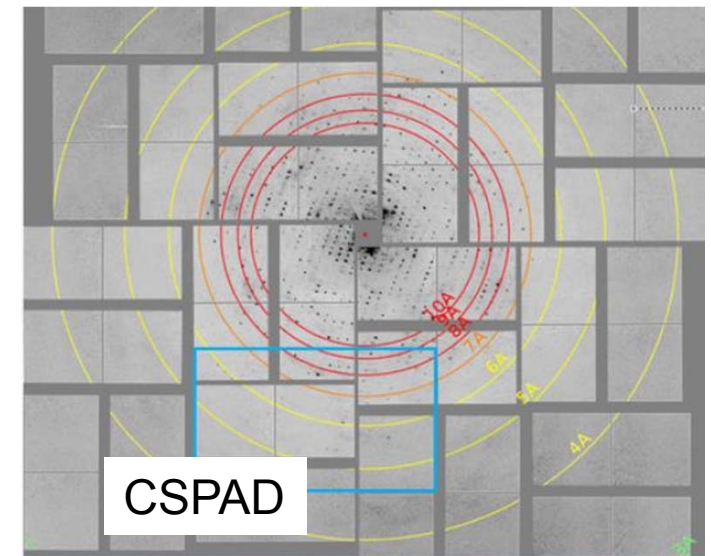
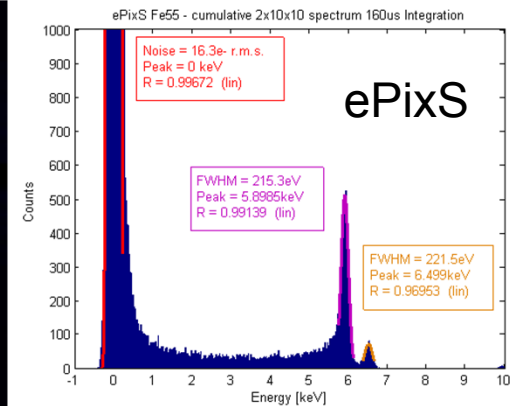
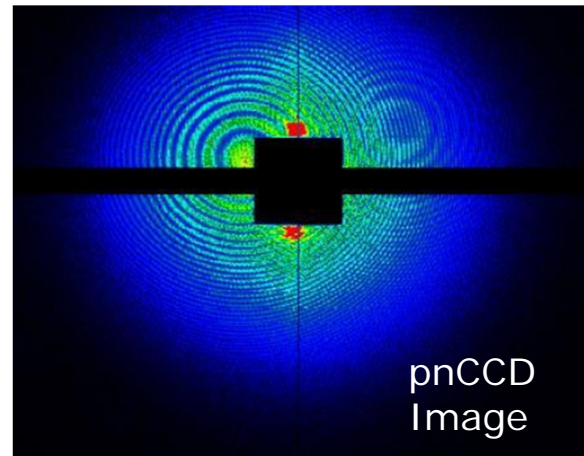

Technology & Innovation Directorate (TIR) Advanced Instrumentation for Research (AIR) Division

All-Hands Meeting

Integrated Circuits Department
Angelo Dragone – Department Head
February 18, 2015



AIR Integrated Circuits - Competences

AIR Integrated Circuits Department
(A. Dragone)



A. Dragone



D. Freytag



P. Caragiulo



B. Markovic



S. Ayers



C. Tamma

Develop Application Specific Integrated Circuits (ASIC)
for:

- The processing of signals from radiation detectors
- The control of radiation detectors

Areas of expertise:

- mixed-signal architectures
- low noise analog front end
- noise filtering optimization
- high speed, mixed mode blocks
- digital data transmission

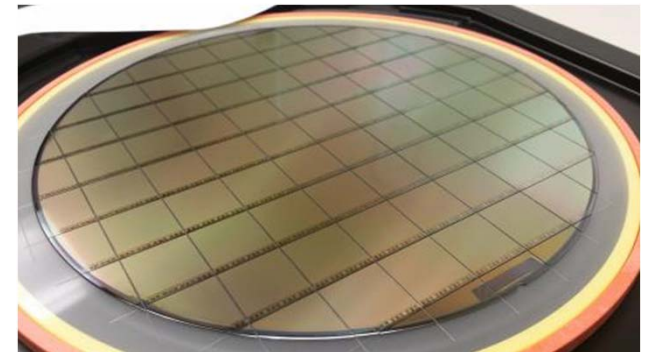

An ASIC is a kind of integrated circuit that is specially built for a specific application or purpose. Compared to a programmable logic device or a standard logic integrated circuit, an ASIC can improve speed, power consumption and density because it is specifically designed to do one thing and it does this one thing well. Because ASICs are all custom-made and thus only available to the company that designed them, they are considered to be proprietary technology and thus in our case a core competency.

AIR Integrated Circuits – some of our works

- Photon Science

- LCLS
- LCLS II
- SSRL



- High Energy Physics

- ILC
- ATLAS
- nEXO



- Astro-Physics

- Fermi telescope



- Neuroscience / Medical Imaging



- Work for Others

Completed/ Advanced	Under development
<ul style="list-style-type: none"> • eLine100 • eLine10k • sLine • ePix100 • ePix10k • ePixS 	<ul style="list-style-type: none"> • tPix • cPix² • ePixM • ePixF • ePixΔ • ePix100k • ePixHR • eLineS
<ul style="list-style-type: none"> • kPix • Bean • Chess (with UCSC) 	<ul style="list-style-type: none"> • kPixM-Trk • kPixM-Cal • Titan • Cryo
<ul style="list-style-type: none"> • 9 ASICs in space 	



ePix100: 28 Million transistors. Bigger than an AMD Athlon K6 and slightly smaller than a Pentium 4



ePixS: a 100 channels signal processor for spectroscopy with a floor noise of 8 e⁻ rms

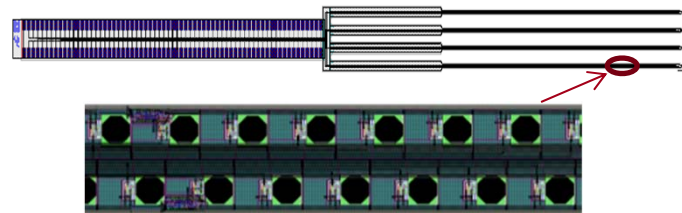

Spike: a 4 prong active probe with 1024 recording channels (with sensor department)

Technology & Innovation Directorate (TIR) Advanced Instrumentation for Research (AIR) Division

All-Hands Meeting

Electronics Systems Department
Ryan Herbst – Department Head
February 18, 2015



Electronics Systems

- David Brown, Mark Freytag, Ryan Herbst, Maciej Kwiatkowski, David Nelson, Kurtis Nishimura, Jeff Olsen, Ben Reese, Larry Ruckman, Leonid Sapozhnikov, Chengchen Xu
- Provide hardware, firmware & software to support science
- Work closely with all AIR departments to provide a system level design solution
- Experienced integrating third party hardware and software (we learn fast!)
 - APV25 & CSPAD ASICs
 - JLAB CODA data acquisition & trigger system
 - ATLAS trigger system
 - Fermilab ArtDaq
 - Nova timing system
- FPGA & ASIC Design
 - Large scale high speed FPGA design
 - Data reduction and online processing firmware
 - RF systems support
 - Digital cores for ASICs
 - Extensive centralized VHDL library
 - Generic module based build system
 - Focus on generalization and reusability

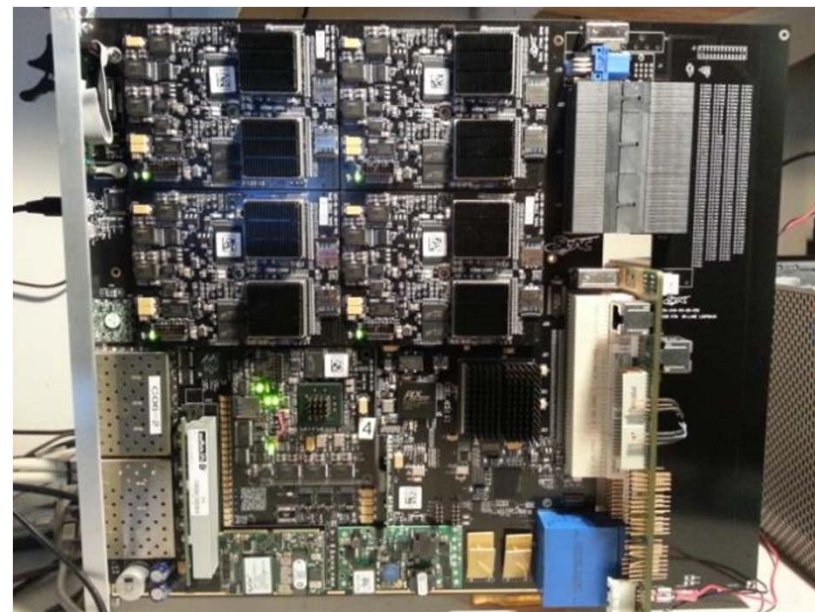

Electronics Systems

- Digital & analog board design
 - High speed > 10Gbps optical
 - High density multi-layer boards
 - Low noise analog circuits
 - Centralized schematic symbol database
 - Low temperature circuits
- Software development
 - Data acquisition and configuration software
 - Linux hardware drivers for Intel & ARM platforms
 - Application software for design testing, board bring up & analysis
- Software tools support for AIR division
- EEIP Services

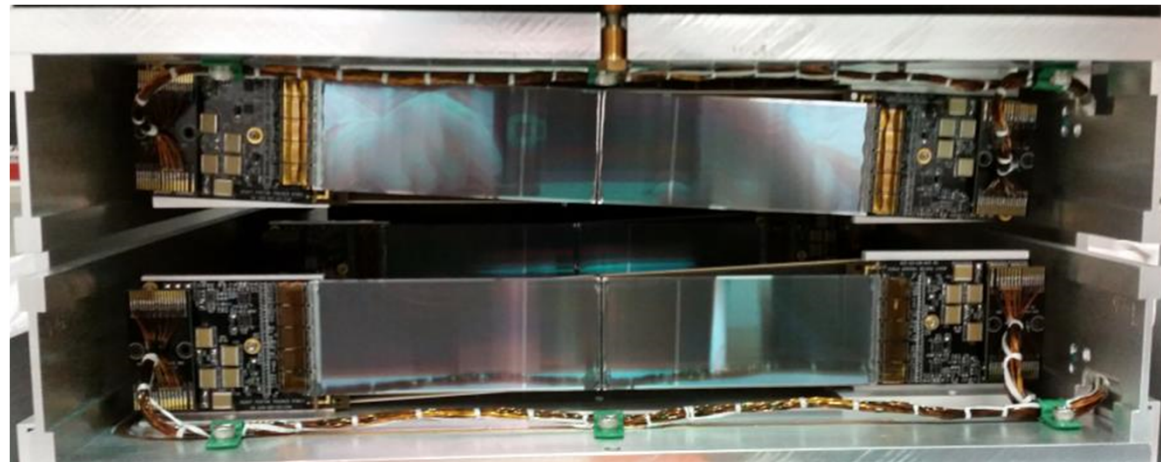
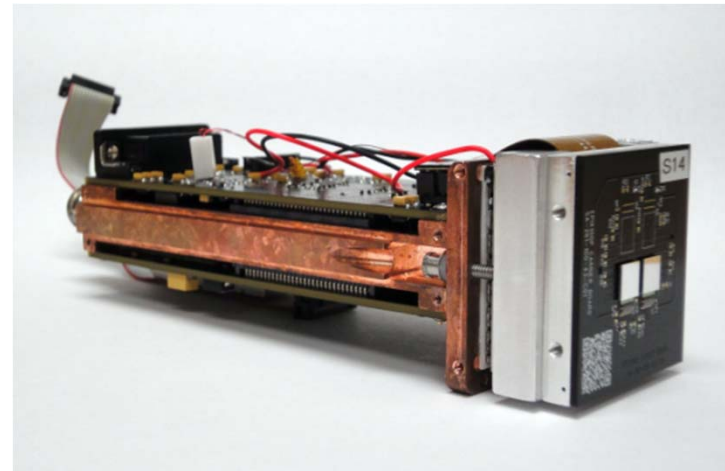

- Technical Writing
 - Mark Arndt & Robert de Peyster
 - Support proposals and technical papers
 - Author specifications and technical manuals for projects
 - Support design review documentation
 - Provide change / document control services
- Board Layout
 - Tung Phan
 - Luong Dai, Kathy Pham, Chuck Yee
 - High speed / low noise designs
 - Hand routed boards
 - PADs and Altium
 - Maintain common footprint library
 - Face panels and chassis

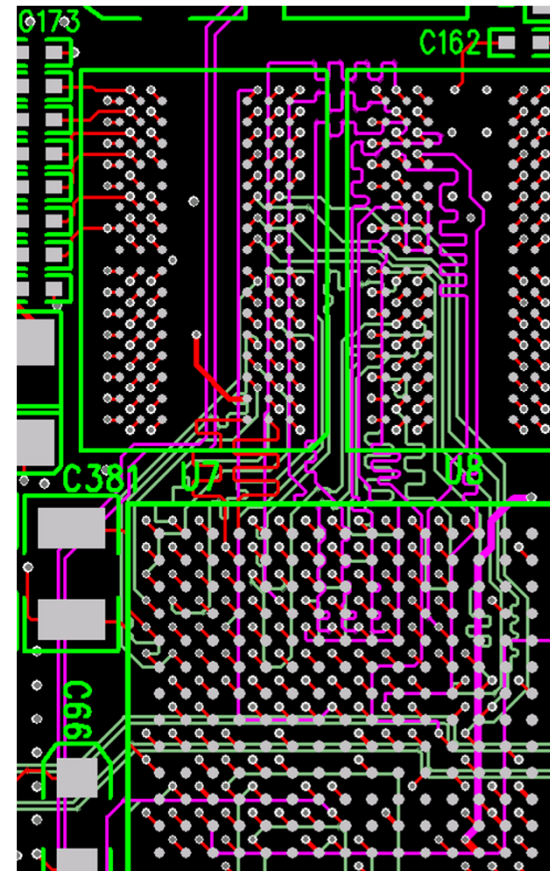

Electronics Systems

- Electronics Shop
 - Lupe Salgado
 - Tan Dang, Danh Du, Hau Van Ninh, Michael Ovelman, Thanson To
 - Local board assembly & rework]
 - Interface to Amtech for assembly, wire bonding, etc
 - Cables assembly & termination
 - Chassis & din rail assembly
 - Board & cable cleaning
 - Parts procurement
 - Software & license procurement
 - Component stocking & inventory
 - Equipment procurement, storage & tracking
 - Interface for equipment repair & calibration
 - Shipping coordination



Technology & Innovation Directorate (TIR) Advanced Instrumentation for Research (AIR) Division

All-Hands Meeting

RF Systems Department
Joe Frisch – Department Head
February 18, 2015



RF Systems

John Dusatko, Joe Frisch, Bo Hong, Lili Ma, Steve, Smith, Dan Van Winkle, Andrew Young



High precision, high frequency electronics

Femtosecond timing, instrumentation, high bandwidth control systems.

Projects for LCLS Accelerator, LCLS Experiments, LCLS Mission Readiness, LCLS_II, FACET, ASTA (UED), SSRL, and several outside laboratories

RF electronics, detectors, transmitters, and signal processing.

We also have significant expertise with Accelerators, detectors, mechanical design and control systems

Or in summary: We build radios

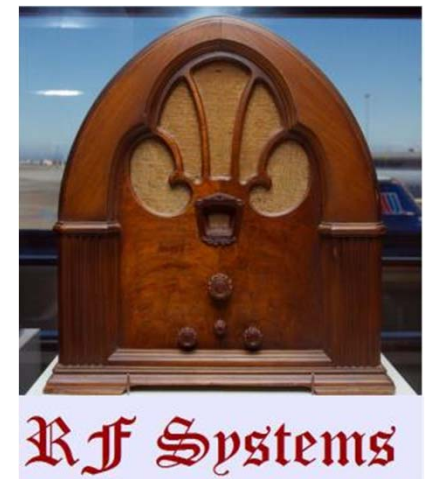

RF Systems: Precision Timing

Low phase noise and drift sources for SLAC

Accelerator and experimental stations
Few-femtosecond integrated noise
>4 kilometers distribution

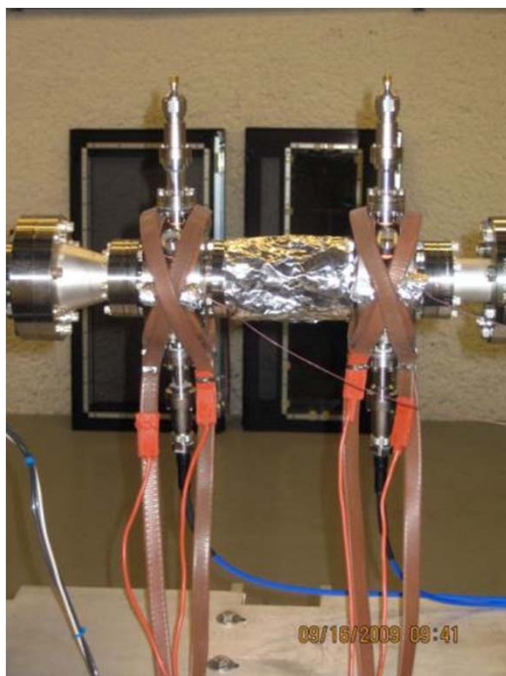
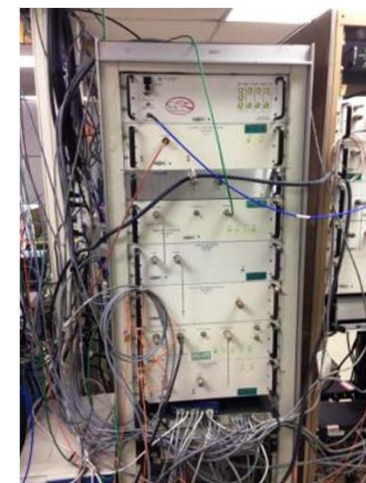

Beam Arrival Time Monitor

10fs timing noise for LCLS timing experiments.

LLRF Systems



Femtosecond laser lockers

Used for femtosecond lasers all over SLAC
<25fs rms jitter

RF Systems: Instruments

Electron Beam Position Monitors

LCLS, LCLS_II and Mission Readiness:
Striplines and ultra-high resolution (<250nm) Cavity
BPMs

WFO projects for Pohang FEL, and ESS

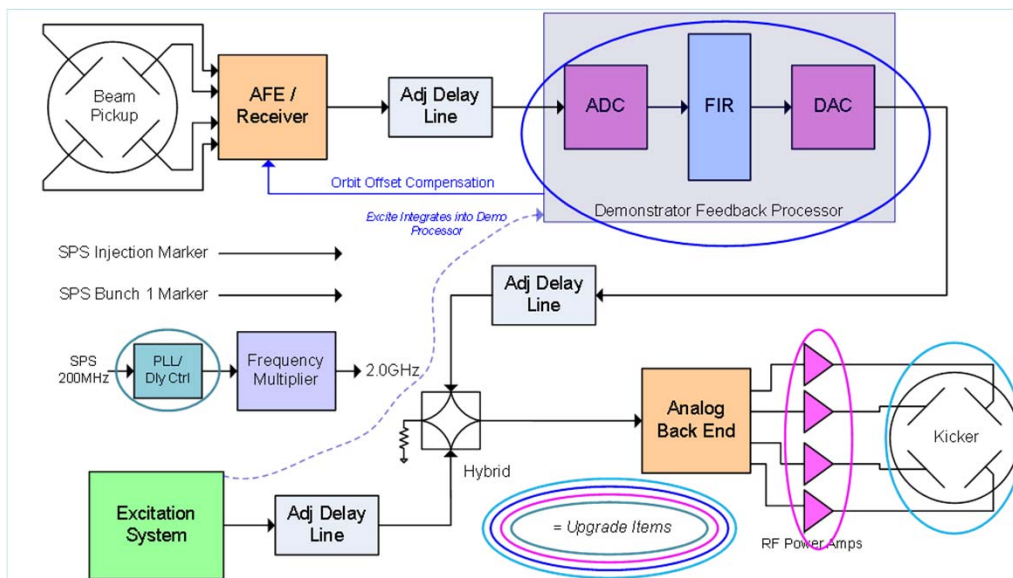

Ultra-Wideband beam feedback
for CERN SPS proton beam:
4Gs/s, upgrading to 8Gs/s.

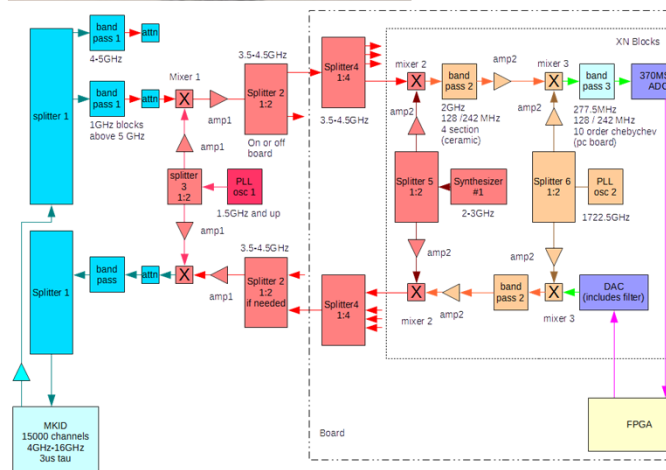

Electronics for cryogenic array detectors
X-ray imaging with energy resolution.
Very wide bandwidth, high channel count
RF receiver / tracking source.

Technology & Innovation Directorate (TIR) Advanced Instrumentation for Research (AIR) Division

All-Hands Meeting

Controls Systems Department
Ernest Williams – Department Head
February 18, 2015



Advanced Control Systems Department Mission

What we do:

- **Research and select control system platforms and computer architectures viable for building complex, real-time distributed control systems.**
 - PLCs, Industrial Block I/O, xTCA, Industrial PCs
 - X86, FreeScale, ARM, ...
 - Control system fieldbuses and low-latency networks/fabrics
 - EtherCAT, ProfiNet, EtherNet/IP, 10/40G ethernet
 - PCI Express, Rapid I/O ...
- **Provide and maintain quality control system core software modules used to build control systems.**
 - EPICS: (BASE + Extensions + Modules)
 - RTOS and OS development for embedded real time systems
 - Low level firmware, device driver, and complex multithreaded programming:
(Close integration and collaboration with Ryan's team)
- **Motion Control System Architecture and Platform Research, selection and development.**

What we do:

- **Research and select or develop software infrastructure, tools ...**
 - Configuration management (development, build, debug, test, release and deployment)
 - SVN, GIT, GNU make, python-based scripts ...
 - Automated nightly builds plus regression test suite
 - Development of middle-ware/services between control system and high-level applications.
 - Control system GUI tools: EDM, pythonQT
- **Provide expertise in advanced control system methods and signal processing.**
 - Beam-based Feedback
 - Beam Position Monitor processing algorithms

Involvement/Projects:

- **We are involved in projects both internal and external to the Lab:**
 - FACET, LCLS 1, LCLS 2, ASTA (UED), SPEAR3
 - LCLS 1 FEE and Experimental Stations
 - WFO: Pohang XFEL
- **Control System Test Stand Development and Support**
 - Motion Control
 - Beam-based Feed
 - Timing system
 - xTCA

Outlook:

- We will work with the WFO to develop new business:
- Using our core competency: work and support projects inside and outside of AIR
- Provide a path to centralize common software and controls hardware across facilities at SLAC:
 - Different versions of EPICS everywhere ☹️
 - Different version control repositories
 - Different version of drivers for the same hardware
- Provide a path to migrate and use same controls hardware platforms where appropriate
- Lead Development and Deployment of High performance systems for LCLS 2

Technology & Innovation Directorate (TIR) Advanced Instrumentation for Research (AIR) Division

All-Hands Meeting

Data Systems Department
Matt Weaver – Department Head
February 18, 2015



AIR High-speed high-volume DAQ systems

Department: Sergio Maldonado, Gregg Thayer, Stephen Tether, Jim Panetta

Ric Claus, JJ Russell, Anthony Waite

Current single ATCA module can receive data up to 144 Gb/s! from detector or from/to other data sources

On-board switching to transport data between on-module computing nodes up to 40 Gbit/sec

Transport data from each module to rest of crate up to 520 Gb/s

Ported and bundled with operating system and real-time kernel

Already used or baseline for numerous projects

- LHC Atlas (current and upgrade), LSST, HPS, LBNF, nEXO

Potentially many applications where high speed communication and/or fast processing of packets/data is needed

- Lattice QCD
- National security, packet sniffing
- etc

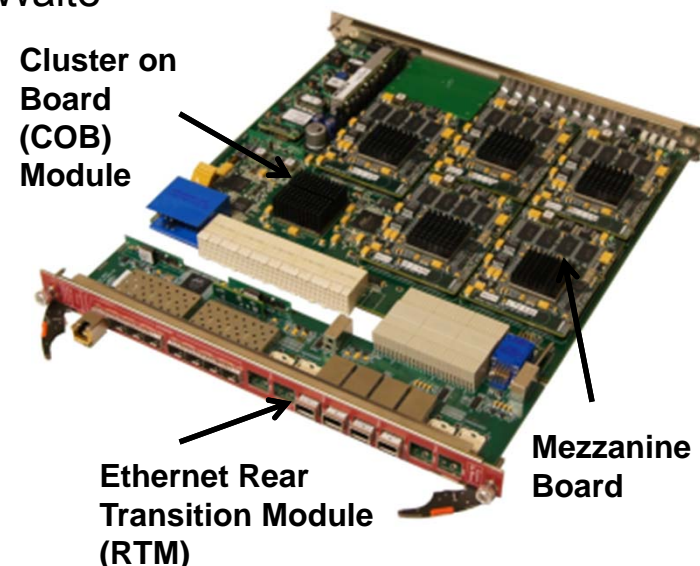

5-slot ATCA Shelf,
but can have crate up
to 14 slots

AIR LCLS Data Acquisition

Chris Ford, Jack Pines, Matt Weaver, Tomy Tsai

- Responsible for core software running in 6 experiment acquisition systems
 - New experiments/users every week
 - Mixture of commercial and custom sensor systems
 - Interfaces for automated run control, configurable event quality feedback
- Generic distributed online analysis + GUI
- New sensor integration/evaluation
- Preparing LCLS-II acquisition system design
 - Extends acquisition event rate from 0.1-120 Hz range to 0.1-1,000,000 Hz
 - Layered triggering system

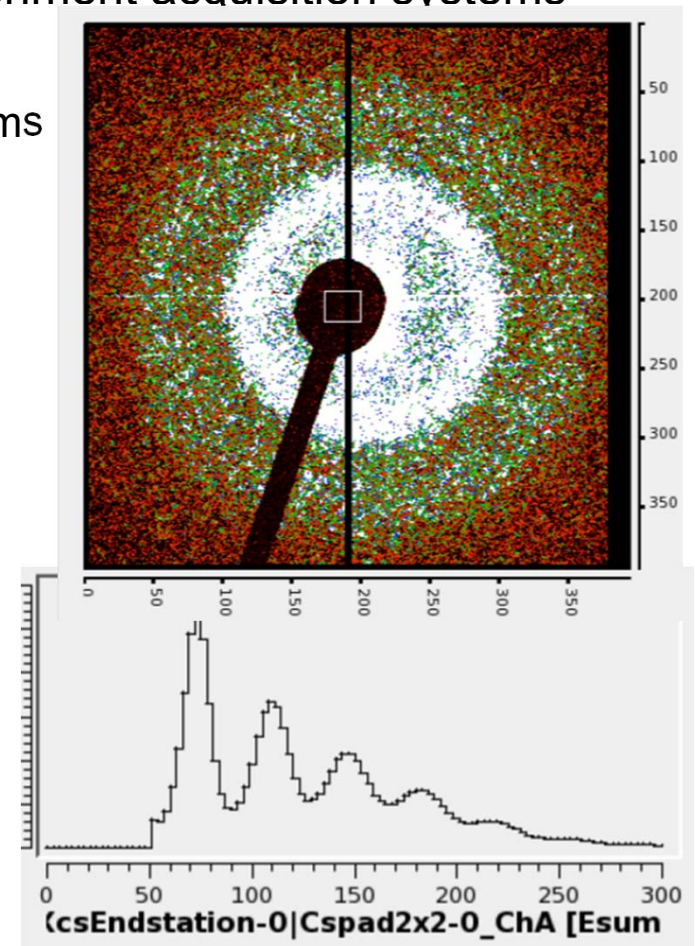

AIR LCLS Data Analysis Group

Chris O'Grady, David Schneider, Mikhail Dubrovin

- Emphasizing more user-friendly languages like [python](#)
- Run [same analysis code in real-time or offline](#)
- Real-time/offline [parallelization](#) (e.g. using MPI)
- Detector [calibration and analysis](#) algorithms
- Data [storage formats](#) (e.g. HDF5)

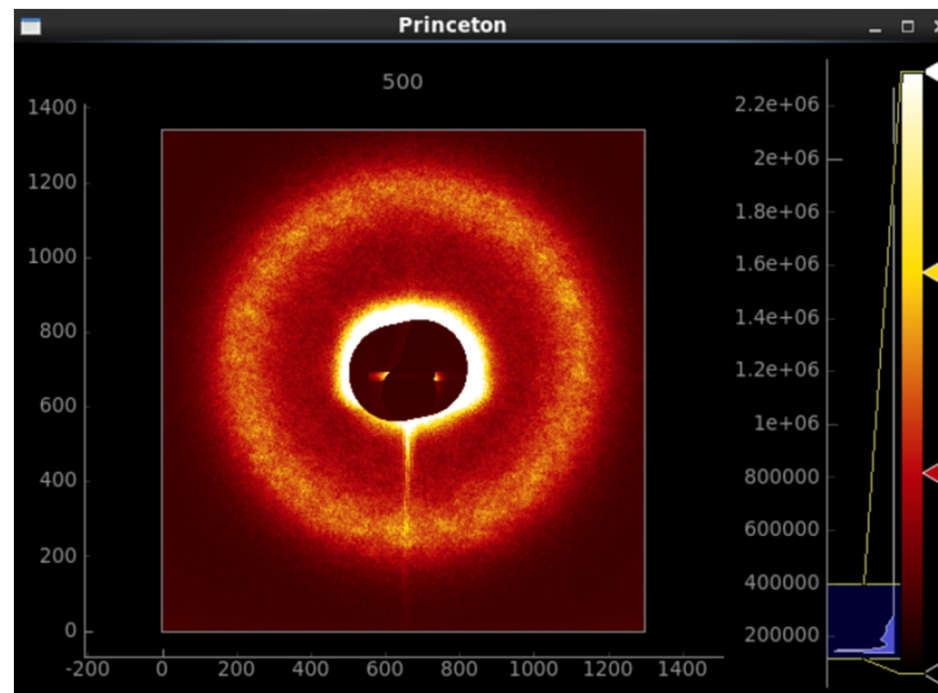

Conclusion

SLAC

- Support accelerator and science projects and experiments with innovation and cutting edge technologies
- Explore new opportunities in other fields where our competency can make a difference
- Please come to me any time if you have any questions
- Q&A