

REV.	DESCRIPTION	DRN.	CHK.	APP.	DATE
△	GENERAL MODIFICATIONS	GRV	JKC	K.S.	6/1/87
△	RELOCATE BEAM ON SECT. A & B & ELEV.	GRV	JKC	K.S.	7/2/87

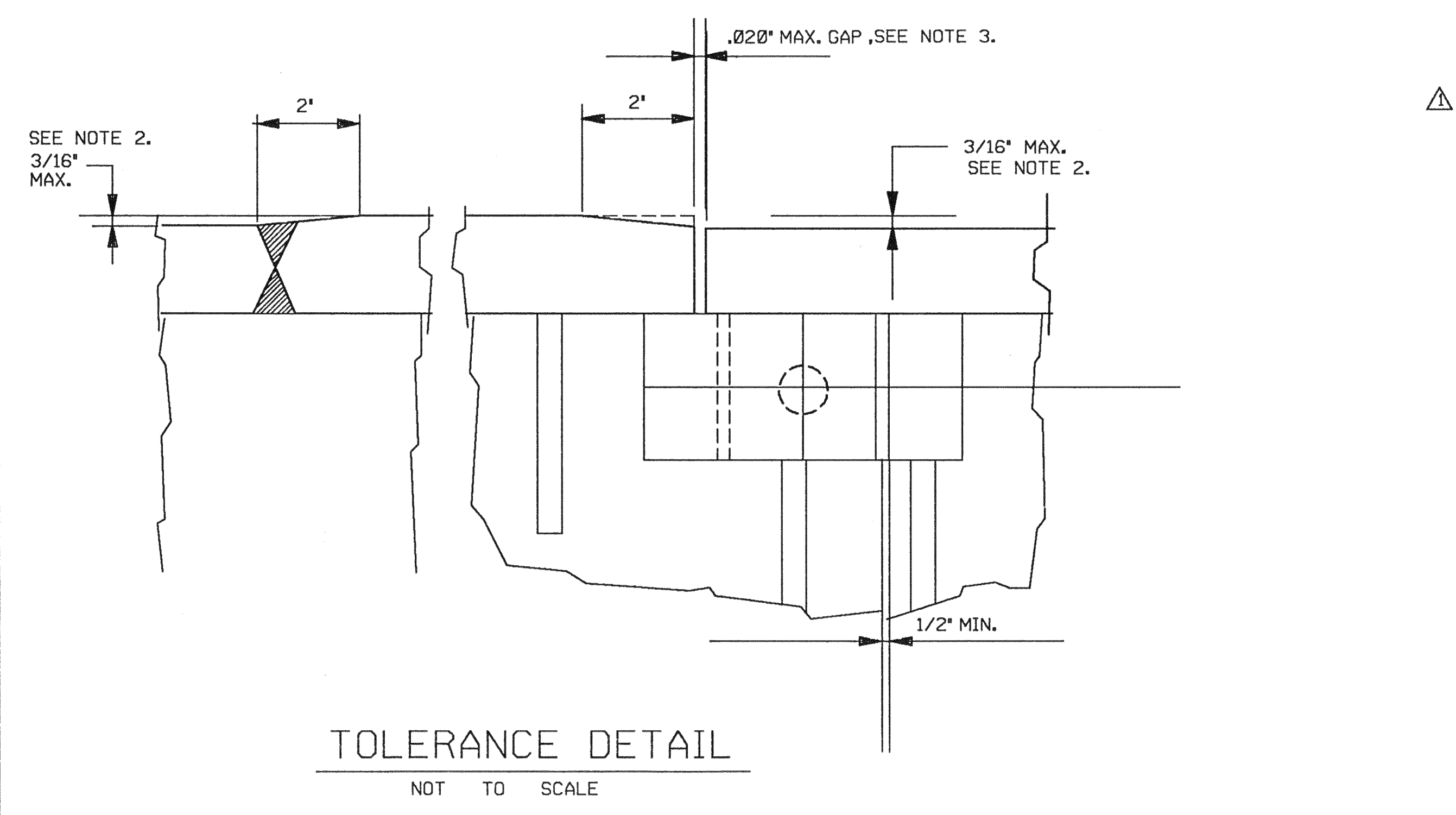

- NOTES:**
- UNLESS OTHERWISE SPECIFIED DIMENSIONS ARE IN FEET & INCHES
TOLERANCES: ± 3/16"
ANGLES: ± 0°20'
 - DISCONTINUITY OF TOP SURFACE OF BEAMS OR PARTS OF BEAM, SHALL NOT EXCEED 3/16" INCH IN ELEVATION, AND ALL DISCONTINUITIES SHALL BE GRIND TO A SMOOTH RAMP OVER A MINIMUM HORIZONTAL LENGTH OF 2 INCHES.
 - WHEN BEAM SECTIONS ARE ASSEMBLED WITH THREE SHEAR PINS, THE BUTT JOINT BETWEEN THE TOP PLATES, SHALL HAVE A MINIMUM OF TWO CONTACT AREAS AND A MAXIMUM GAP AS SHOWN.
 - WITH ALL THREE SUPPORT STANDS RESTING ON A HORIZONTAL PLANE THE TOP SURFACES OF THE TOP PLATES SHALL FOR ALL CROSS SECTIONS BE LEVEL WITHIN 1/4 INCH.
 - WHEN BEAM SECTIONS ARE ASSEMBLED WITH THREE SHEAR PINS AND SUPPORTED BY THREE STANDS, TOP SURFACE OF BOTH BEAMS SHALL BE LEVEL WITHIN 3/4 INCH INCLUDING THE DEFLECTION OF EACH BEAM SECTION.
 - WHEN BEAM SECTIONS ARE ASSEMBLED WITH THREE SHEAR PINS, THE EDGES OF THE TOP PLATES SHALL BE IN-LINE WITHIN 3/4 INCH.

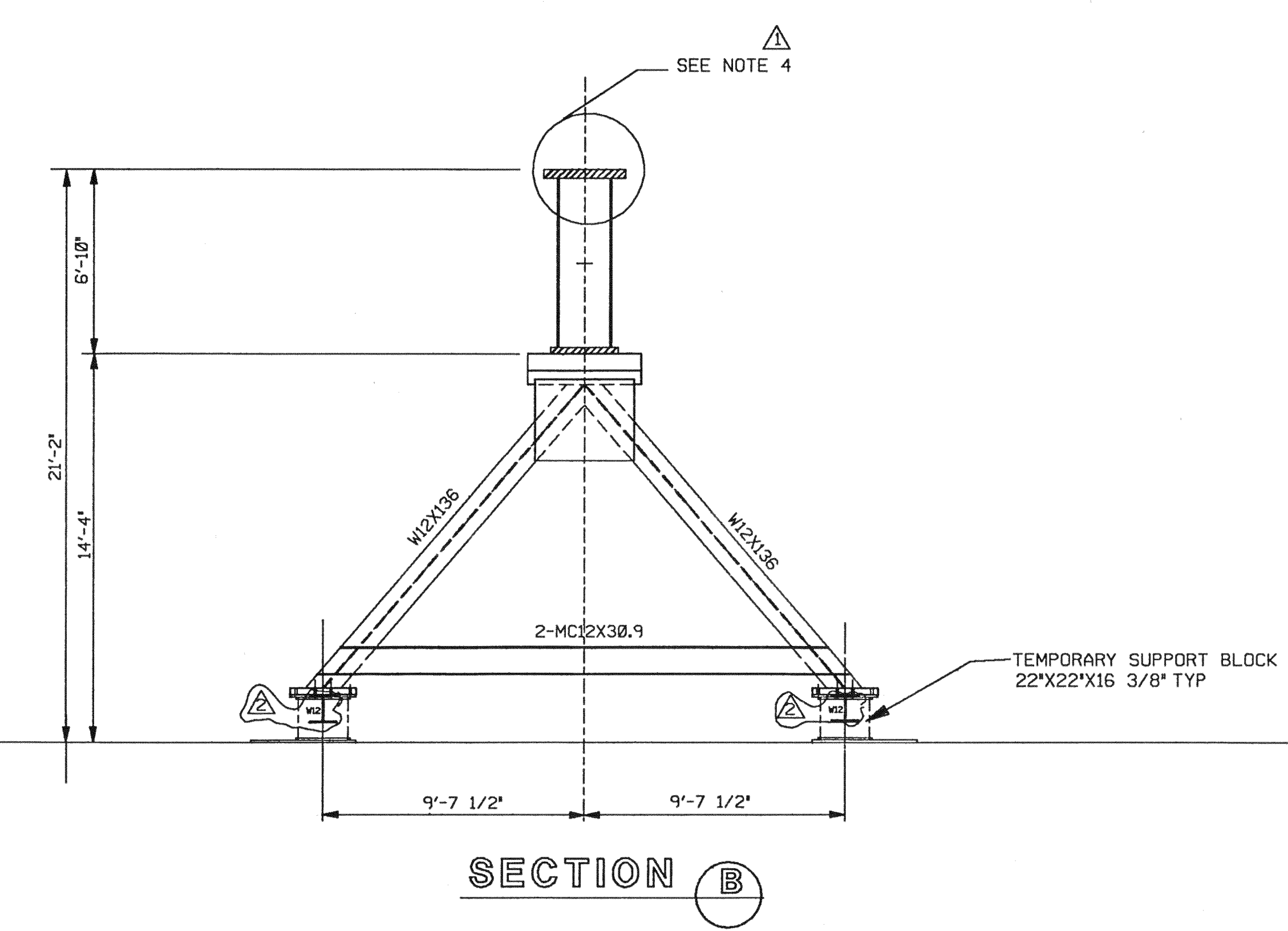
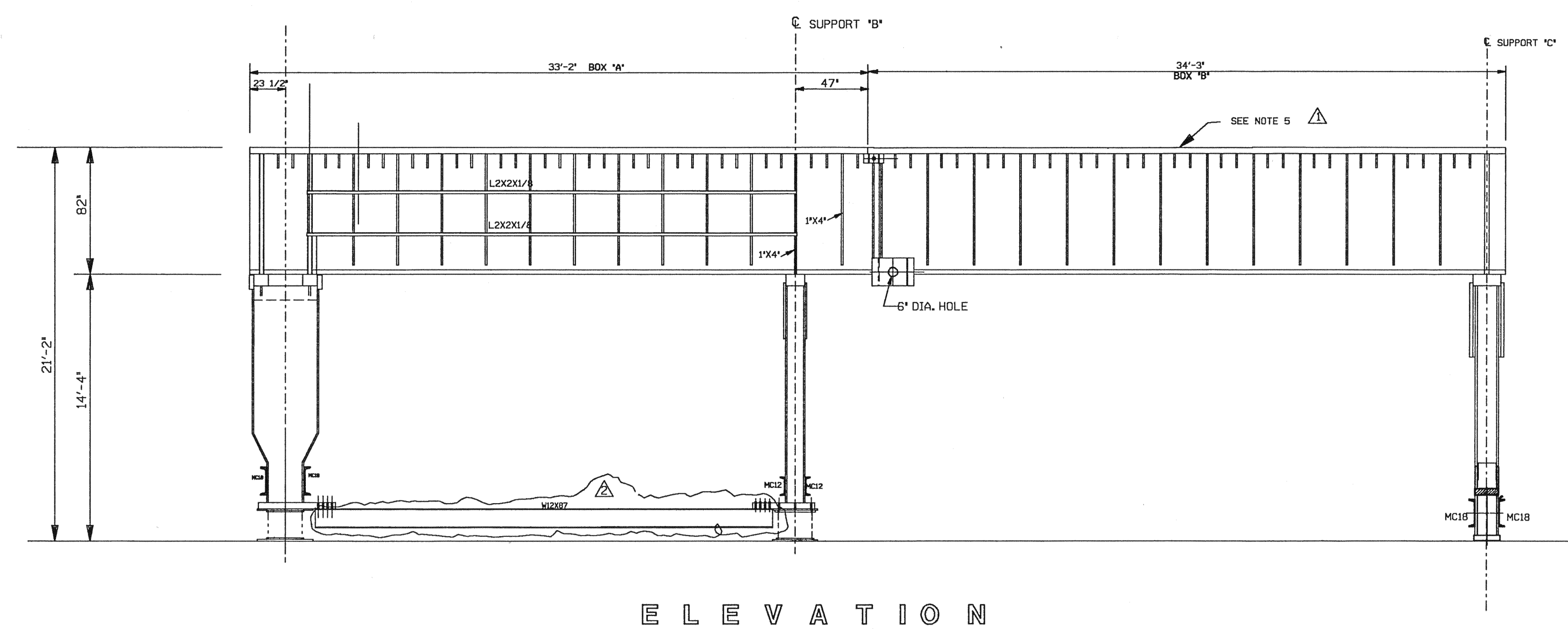
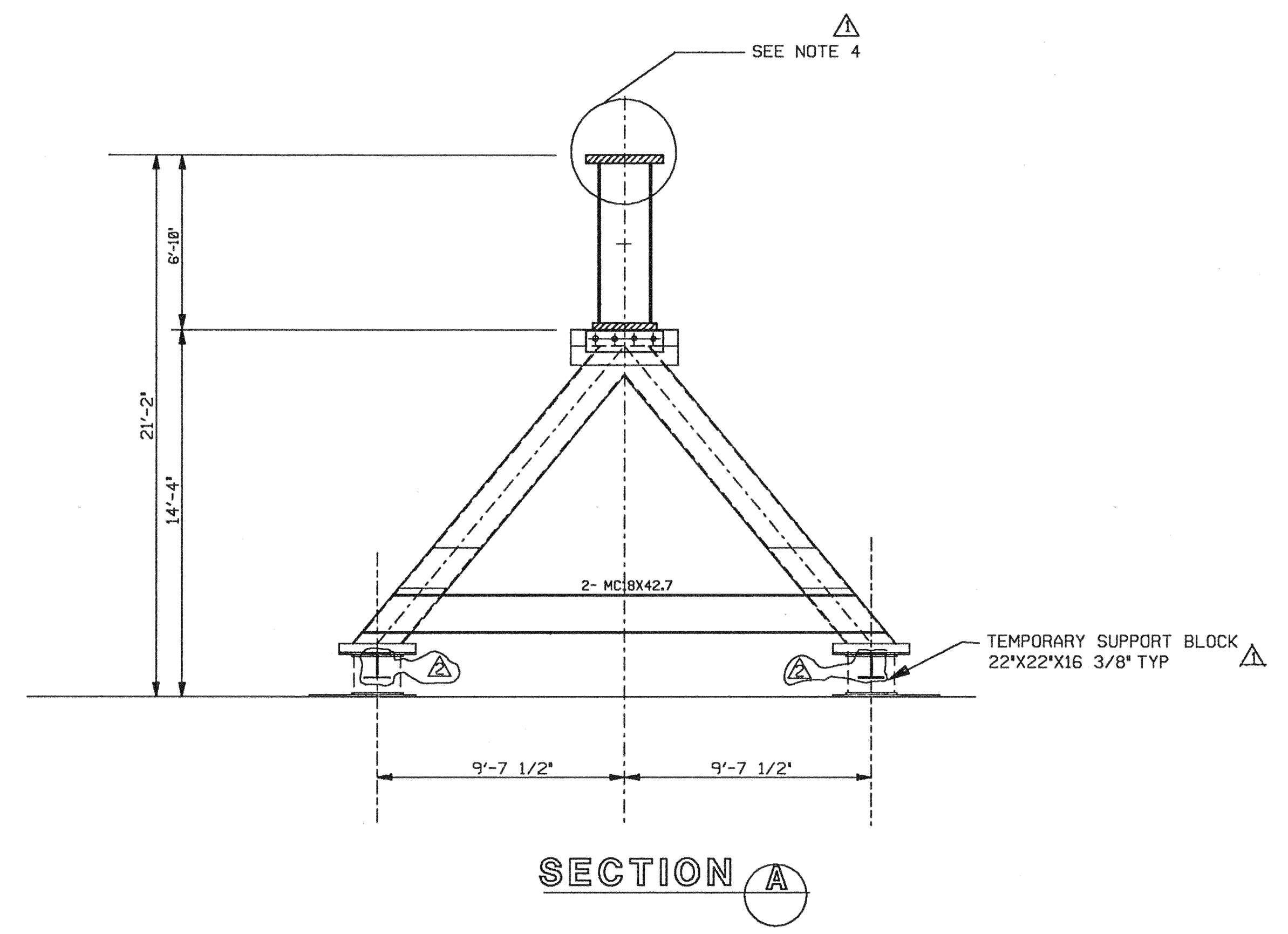
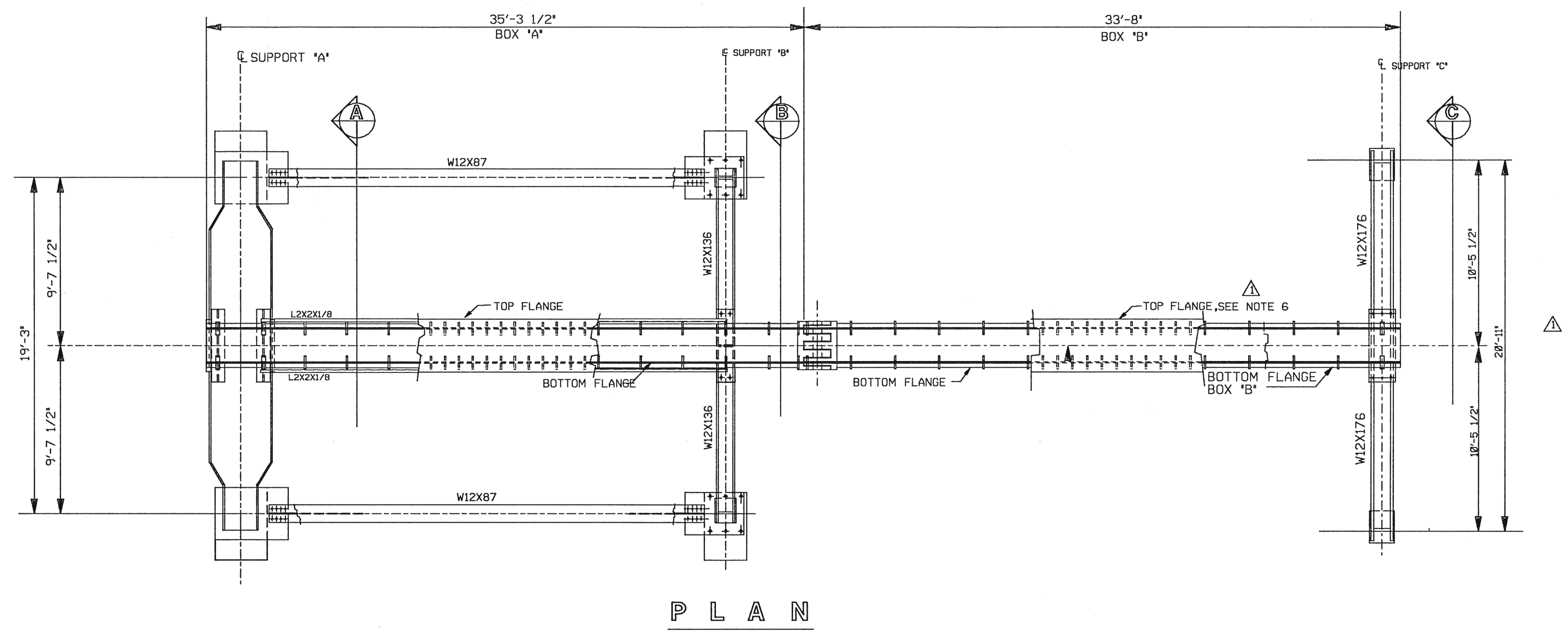
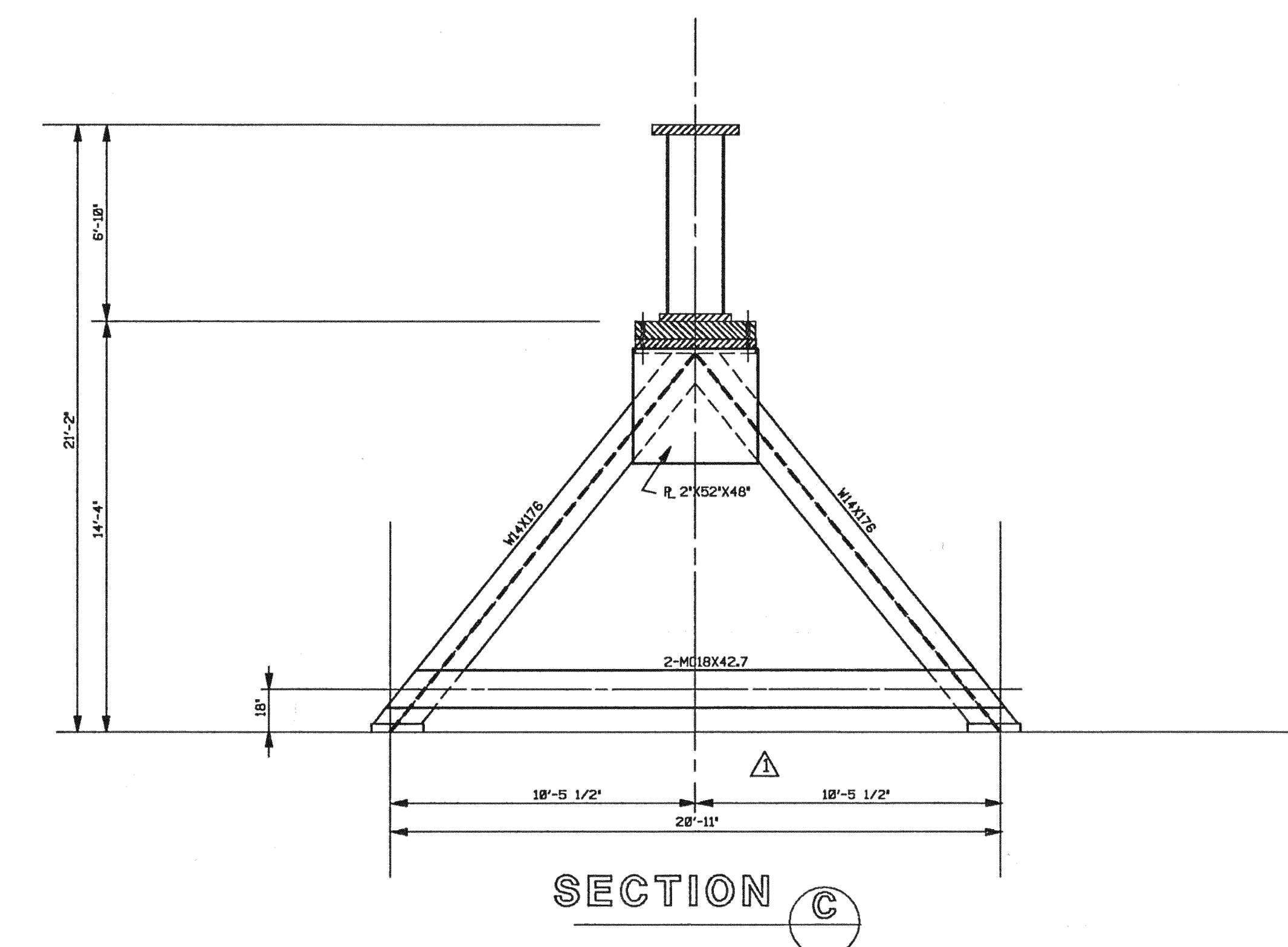

SCALE: 3/4"=1'-0"	DO NOT SCALE DRAWING	PFB/UA39	S-1
STANFORD LINEAR ACCELERATOR CENTER U. S. DEPARTMENT OF ENERGY STANFORD UNIVERSITY		S.L.D - L.A.C HEAVY ASSEMBLY BEAM GENERAL LAYOUT	
PROPRIETARY DATA OF STANFORD UNIVERSITY AND/OR U.S. DEPARTMENT OF ENERGY. RECIPIENT SHALL NOT PUBLISH THE INFORMATION WITHIN UNLESS GRANTED SPECIFIC PERMISSION OF STANFORD UNIVERSITY.			
ENGR. J. COBMEZ	DRW. K. KARAPAS	APP. K.S.	6/13/87
DFTS. DRY SEASO	RABELL	MCKENBY	
CHK. D. J. GARDNER			
SA	241-521-70 C2	E	

ISA-241-521-70 C2 E