

# SVT requirements for slow controls

Sho Uemura

# SVT subsystems

- Voltages
- Interlocks
- Cooling
- Motion

# Voltages

- MPODs supply HV directly to sensors, LV to frontend and flange boards
  - ▶ Standard equipment at JLab; MPODs are controlled over SNMP and EPICS interface exists (MPOD testing and integration: Sho and Pelle)
  - ▶ Requirements: On/off and voltage control, voltage and current readout
- Regulators on frontend boards supply LV to hybrids
  - ▶ Frontend boards controlled by DAQ; EPICS CA server to be implemented by SVT DAQ group (Ryan)
  - ▶ Requirements: On/off control (voltage setpoints fixed), voltage and current readout, watchdog timer
- SVT voltage GUI from test run is a good starting point; probably want more automation and sequencing

# Interlocks

- Requirements: protect SVT with response time  $< 1$  second, record and monitor conditions
  - ▶ Loss of vacuum
  - ▶ Loss of cooling/break in a cooling line
  - ▶ Beam accident
- Inputs:
  - ▶ Vacuum chamber pressure and temperature
  - ▶ Beam FSD signal
  - ▶ Coolant temperature (RTDs at inlet and outlet)
  - ▶ Coolant flowmeter
  - ▶ Software input from EPICS
- Outputs:
  - ▶ SVT power: interlock input on MPOD chassis controller
  - ▶ SVT cooling: solenoid valve at inlet (outlet has check valve)
- Use Allen-Bradley PLC — flexible, used at JLab, can read out all inputs and status to EPICS
- Logic and procedures by SLAC SVT group (Pelle, Sho)

## Cooling: chiller and SVT temperatures

- Single chiller (Affinity P-series) for all SVT heat loads (hybrids and frontend boards)
- RS-232 control through EPICS
  - ▶ Requirements: setpoint control, alarm status readout, possibly other internal sensors
  - ▶ Interlock functions (external sensors and isolation valves, automatic low level shutoff) do not rely on RS-232
- Setup and testing (including RS-232 control) at SLAC (Marco)
- Hybrid and FE temperatures from thermistors are read by SVT DAQ and CA server (Ryan)
  - ▶ Interlock does not rely on this

# Motion

- Linear stages for SVT top, SVT bottom, target (requirements for target discussed under beamline talk)
- Requirements: control position, readout rotary encoder and contact switches (in-limit and out-limit)
- Reproducible ( $25\ \mu\text{m}$  at layer 1) and adjustable run position
- Wire scans using wires on SVT
- Stages already in hand but need to be tested at SLAC (Takashi, Sho); need JLab motor drivers and EPICS-in-a-box system

# SVT Slow Control: Power and Temperature

Power to SVT from Wiener MPOD power supplies

General requirements from slow control

- Control and monitor all power supplies channels
- Monitor temperature and status
- Provide hardware and software interlock signal to power supplies

EPICS control and monitoring requirements

- Power to FE- and flange boards and high voltage bias through MPOD crate
- Control of hybrid power through SVT DAQ EPICS bridge
- Monitor hybrid and FE board temperatures and status

Schedule

- Week 12/16: SLAC receives power supplies
- Week 1/15: pass basic tests at SLAC [Hansson, Uemura]
- Week 3/17: EPICS bridge for SVT tested [Herbst]
- Week 5/19: EPICS control power for DAQ tests at SLAC [Egyian, Hansson, Uemura]
- Week 7/14: interlock integration tests [Egyian]

## EPICS variables

Hybrid	Type	Variables
AVDD	SVT CA server	Set: ON/OFF Read: V, I
V125	SVT CA server	Set: ON/OFF Read: V, I
DVDD	SVT CA server	Set: ON/OFF Read: V, I
Temperature	SVT CA server	Read: T

FE Boards	Type	Variables
AVDD+	MPOD control	Set: ON/OFF, V Read: V, I
AVDD-	MPOD control	Set: ON/OFF, V Read: V, I
DVDD+	MPOD control	Set: ON/OFF, V Read: V, I
Temperature	SVT CA server	Read: T

Flange Boards	Type	Variables
DVDD	MPOD control	Set: ON/OFF, V Read: V, I

Bias voltage	Type	Variables
HV	MPOD control	Set: ON/OFF, V Read: V, I

# SVT Cooling Requirements

Hybrids	
Operating T	-30C to RT
Cooling cap.	100W@-30C
Mass flow	>50g/s

Affinity P-series RC50222G1



- Water cooled: use Hall-B water
  - Compatible with water-glycol
  - -40C-RT
  - 3kW@-30C
  - 85psi@60g/s
  - RS232 software interface
- Budget & schedule:  
\$30k (budget is \$X)

FE boards	
Operating T	RT+-10C
Cooling cap.	100W@20C
Mass flow	>50g/s

Affinity FAA-015D-DD01CA

**Used in the test run!**

- Water cooled: use Hall-B water
- Compatible with water-glycol
- +4-+30C
- 6kW
- RS232 software interface

Budget:  
- Chiller \$30k (budget is \$29.8k)

- Schedule:
- Apr. 1<sup>st</sup>: new chiller arrive
  - May 1<sup>st</sup>: Passed basic op. test at SLAC [M. Oriunno]
  - May 7<sup>th</sup>-Jun 7<sup>th</sup>: slow control program. and test at JLab [H. Egyian]
  - Jul.-Aug. interlock tests [H. Egyian]

⇒ Lead-time for chiller pushes schedule  
⇒ Critical to get chiller to JLab <X

Interlock signals from cooling system

*Same as test run*

Signal	Type	Signal	Type
Low level	software	Flow meter	hardware
Low/high pressure	software	Check valve	hardware
Solenoid valve	hardware	Temperature	hardware



# Chiller Affinity P-series RC50222G1

SLAC

## System Performance Characteristics

Model Nomenclature	PWG-060K-BE44CBD2
Part Number	900-50222-000
MET Listed to UL1995	Yes
CE Marked	Yes
Weight	575 lbs, shipping weight
Dimensions (l, w, h)	(in) 29.0, 19.25, 45.75 (cm) 73.7, 48.9, 116.2
Ambient Temperature Range	41° F - 104° F (5° C - 40° C)
Process Temperature Range	-40° F - 194° F (-40° C - 90° C)
Communications	RS232
Nominal Cooling Capacity	2 kW @ -40° F
Nominal Process Heater	2 kW at 240 Volt
Pump Performance	3.5 gpm (13.2 lpm) @ 55 psi (3.8 bar), 60 Hz
Process Fluid	HFE 7500
Process Fluid Connections	½" Swagelok
Facility Water Connections	¾" Female NPT
Electrical Configuration:	
Voltage @ 60 Hz	208-230 Volts +/- 10%
Voltage @ 50 Hz	200-220 Volts +/- 10%
Phase	3
Total Amps	37.2
Maximum Fuse Disconnect	60 Amp (required of customer)
Refrigerant	R-507

Notes: Data @ 30°C/86°F unrestricted ambient air for air-cooled chillers.  
Capacities decrease with increasing ambient temperature.  
Data performed with HFE 7500 as the process fluid.

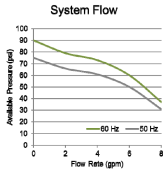
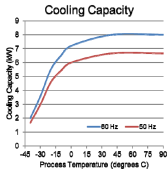

# SVT Cooling Requirements

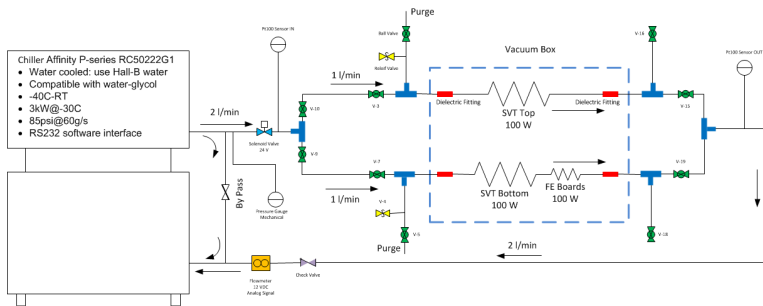

## SLOW Control items :

- 2 x Pt100 Sensors
- 1 Flow meter 12 VDC, Analog Output
- 1 Check Valve
- 1 Solenoid Valve 24V interlocked with Sensors Temp., Flow, Vacuum Gauge
- Chiller Low/High Pressure via RS232 (monitor only)

# SVT mover

Hard-stop

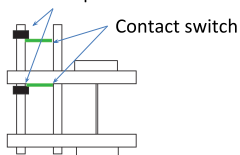

- Two positions
  - Nominal run position
  - Out position
- Nominal run position should have  $\Delta y \sim 25 \mu\text{m}$  reproducibility
- Arbitrary  $\Delta y \sim 100 \mu\text{m} - 1 \text{mm}$  adjustment
- Encoder reset using a precision contact switch
- Position settings:
  - Hard stop:  $\sim 400 \mu\text{m}$  from the beam
  - Contact switch:  $\sim 450 \mu\text{m}$  from the beam
  - SVT Layer 1:  $500 \mu\text{m}$  from the beam

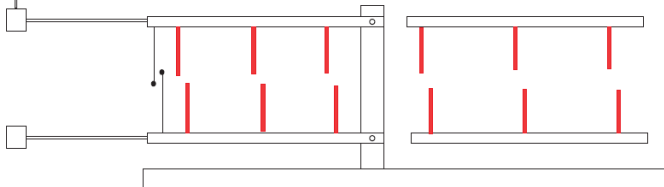

# Mover test

- Motor steps  $\leftrightarrow$  Encoder count  $\leftrightarrow$  SVT layer 1  $\Delta y$
- Contact switch reproducibility
- Beam position reproducibility
  - Reproducibility without encoder reset
  - Reproducibility with encoder reset
- Encoder reset at in-position or out-position
  - Shorter travel from in-position, but probably the beam must be turned off.
  - Longer travel from out-position; takes longer; want to limit long travels.
- Mover speed
  - How fast can we move?
  - Speed-up/speed-down slowly.
- More?

# Test at Jlab or SLAC?

- Jlab
  - VME Crate
  - VME controller with VxWorks 5.5
  - Stepper motor driver box
  - Computer with EPICS software
  - One stepper motor
- SLAC
  - Stepper motor and linear stage
  - Vacuum box
  - SVT support plate and connection to the linear stage
  - C-support and base plate