

SVT Interlocks

Hovanes Egiyan

Introduction

- Either use MPOD chassis-wise interlocks or use board-wise interlocks.
- SVT chiller will need to have an input either of ENABLE or INHIBIT signal.
- Interlock chassis to accept 3 analog inputs
 - Vacuum chamber pressure
 - Vacuum chamber temperature
 - Chiller coolant flow
- Interlock chassis to accept a TTL level from EPICS
- Need to build a dedicated chassis for the SVT interlocks.

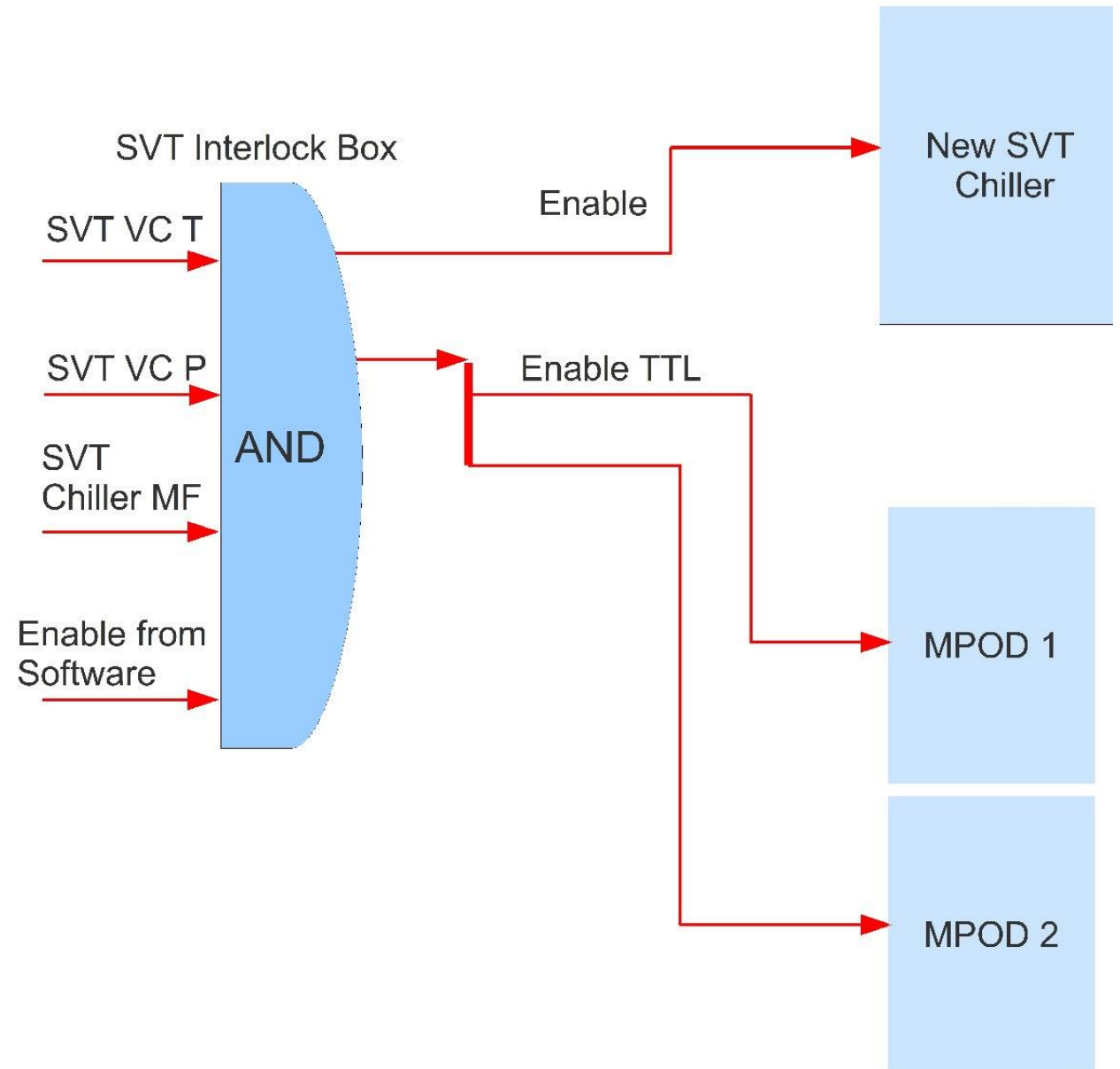

Power supplies

- HPS will need 2 MPOD chassis , with MPV8008 boards and EHS F205-F boards.
- Many labs use these power supplies as standard equipment.
 - Hall D already has experience with using MPOD based chassis
 - Used them during 2012 beam test of GlueX miniBCAL
 - No hardware interlocks are required for GlueX, no in-house experience with this.
 - Interlocks for voltages needs to be designed.
- Interlocks can be either on board level or chassis level
 - Chassis with a controller with a 2-pin LEMO connector
 - All channels on a chassis can be ENABLED by a TTL level (ramp down if zero level)
 - Will shut off ECAL board as well
 - Boards can have option for interlock:
 - ISEG EHS HV modules have SL LEMO connector for safety loop (ENABLE) requiring 5mA current to enable channels on the board. Fast shutoff of all channels on the board there is no current.
 - Wiener MPV 8008 modules can have DSUB-37 with ENABLE per group of 4 channels. If TTL level is zero all channels are turned off.
 - Wiener MPV8008 modules have safety loop connectors for DSUB-37 connector for groups of 4 channels. If the loop is open the 4 channels are turned off.

Requirements and Options

- Have at least three analog inputs.
 - At least one digital (TTL) input.
 - Fast shutdown signal generation (<100ms?). Need input from SVT group.
 - How fast are the MPOD power supplies
 - The chiller shutdown will happen on the order of one second.
1. Hardware chassis
 - Can make very fast decision (~1ms or better).
 - Usually very reliable.
 - Mostly hard-wired, there is limited flexibility to change the number of channels
 - Very limited flexibility to change the logic.
 - Need to figure out how to interface with EPICS to see the statuses and input values.
 - Either Krister or Chris Cuevas' FE group can build it.
 2. Allen-Bradley Programmable Logic Controller (PLC)
 - Modular system, can easily add more I/O modules.
 - Can use the same chassis as for other HPS digital or analog I/O (unrelated to interlocks).
 - Can program any logic at any time if we have license..
 - Easily inefaceable with EPICS to see the statuses and values of the inputs.
 - Decisions can be taken and output can be produced on ~50ms time-scale.
 - Used in Hall D, some local expertise and development platforms are available.

Programmable Logic Controllers

- ControlLogix (1756)
 - 4 Mbyte memory
 - Can be redundant
 - Chassis based
 - Usualt use 10-slot chassis

- CompactLogix (1769)
 - 1.5 Mbyte memory
 - No redundancy available
 - No chassis, DIN-rail
 - L35E Controllers can talk to 32 I/O Modules

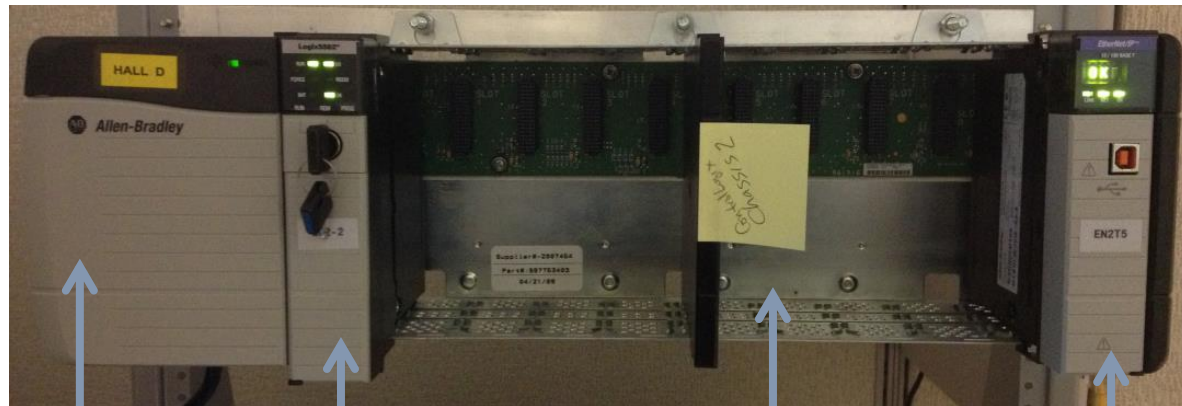

Power Supply

Controller

Chassis

Comm



Controller

Power Supply

I/O Modules