

Hamamatsu S8664-1010 LA-APD test results

S8664-1010 vs S8664-55 Hamamatsu APDs

- Active area and intrinsic capacitance are the two main differences between two sensors. Other properties (Q.E., sensitivity, ..) are the same.

	S8664-55	S8664-1010
Active area	25 mm ²	100 mm ²
Intrinsic capacitance	80pF	270pF

- S8664-1010 APDs will be employed in the JLab HallB Forward Tagger Calorimeter for the MesonEx experiment. This calorimeter is quite similar to the HPS one:
 - PbWO₄ crystals
 - S8664-1010 APDs for light readout
 - Current-sensitive preamplifier coupled to each photo-sensor.
 - See: FT-TDR <http://www.ge.infn.it/~batta/jlab/ft-tdr.2.0.pdf> for technical details
- A test has been performed in Genova to compare the performances of the two sensors when coupled to PbWO₄ crystals and exposed to cosmic rays.

Test setup

- APD has been attached to a PbWO_4 crystal using optical glue (Down Corning 3145 RTV). The assembly was then wrapped with a VM2000 reflecting foil.
- The assembly has been put into a insulated box. Thermal control was achieved keeping it in contact with a pipe connected to an external chiller.
 - Temperature has been monitored through a PT100 coupled to the assembly.
 - Temperature was stable within 0.1 deg during the test.
- The box with the crystal has been put in the middle of a scintillator telescope horizontally, so cosmic muons would pass through it perpendicular to the crystal axis.



Amplifier: the same used for the CLAS12-FT calorimeter, employed both with S8664-55 (currently in HPS calorimeter) and s8664-1010 (large area APD).

Amplifier

- Designed in collaboration with IN2P3 Orsay, starting from the existing CLAS-IC amplifier board.
- Matched to APD Hamamatsu S8664-1010 large area (different input capacitance wrt CLAS-IC APDs)
- Nominal charge gain: ~ 1800 . Output noise ~ 6 mV RMS.
- Output range: 0 – 5 V (linearity guaranteed up to 4.5 V) on 50 Ohm load.

Layout: 3-stages amplifier.

- First stage: NPN transistor common base configuration + voltage follower
- Second stage: OPA694 current feedback op-amp, non-inverting configuration
- Third stage: AD8067 rail-to-rail true voltage feedback op-amp, non inverting configuration

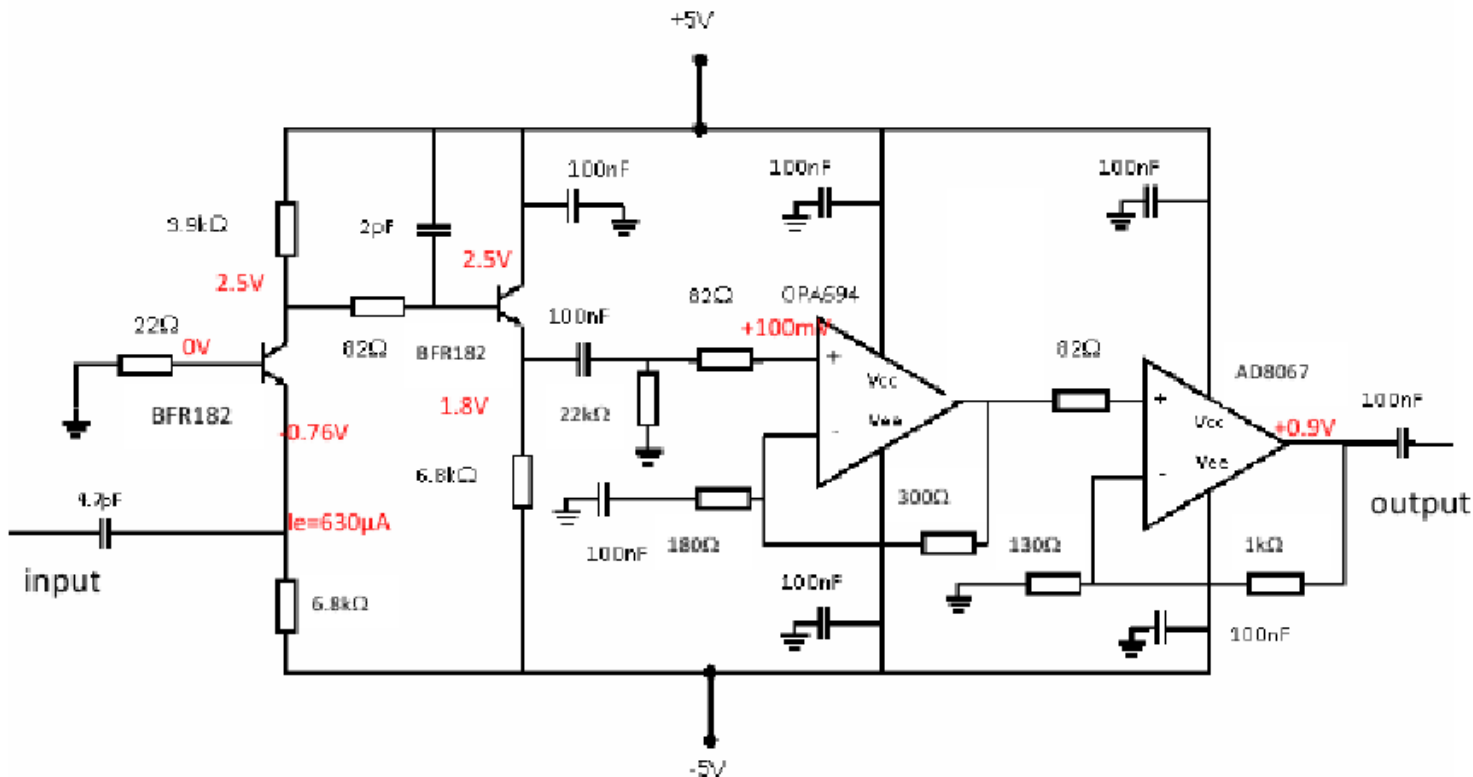

$$G = G_1 \cdot G_2 \cdot G_3$$

$$G_1 = \frac{3.9k\Omega}{50\Omega} \approx 80$$

$$G_2 \approx 2.67$$

$$G_3 \approx 8.7$$

APD Gain measurement

APD intrinsic gain depends on the bias voltage and working temperature. It is necessary to characterize sensor before use to fix the working point and compensate gain differences.

This measure is realized in DC mode using a LED as light source. APD works as a current source”

- 1) Measure the current that flows through APD with LED on, varying the bias voltage in the range $0 < V < 400$ V
- 2) The same measure is repeated with LED off
- 3) Gain is calculated as

$$G(V) = \frac{I_{ON}(V) - I_{OFF}(V)}{I_{ON}(G=1) - I_{OFF}(G=1)}$$

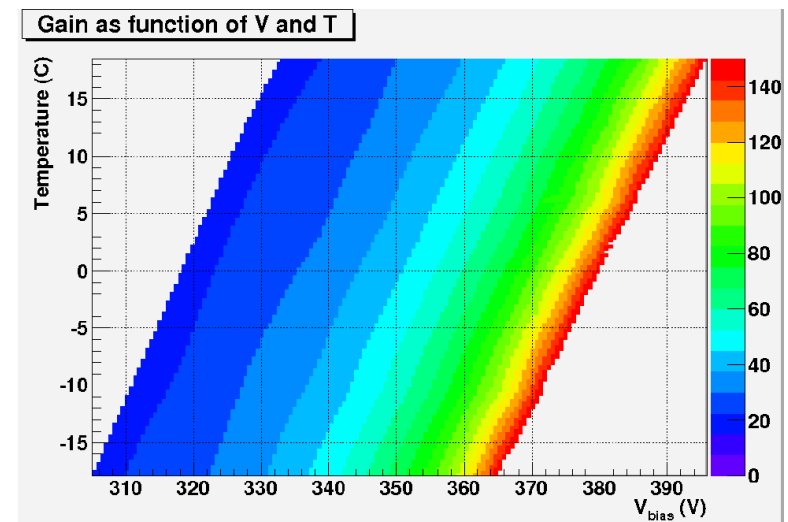
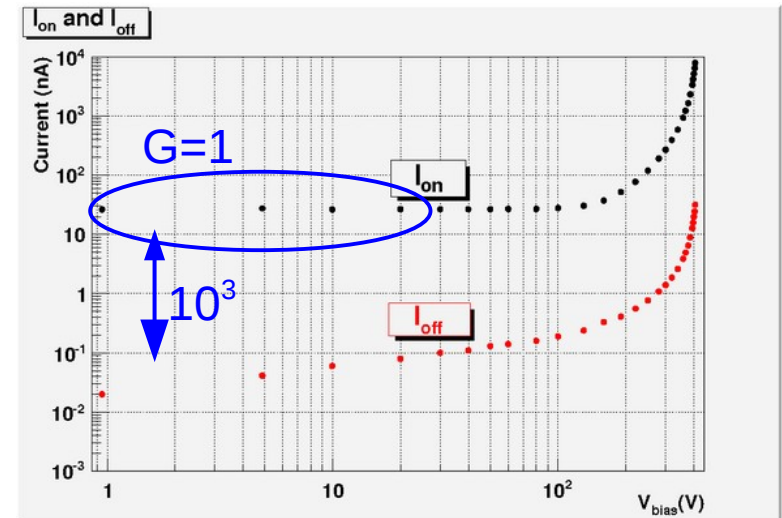

In Genova we have developed an automatic system to measure up to 24 APDs at once, in one day (a paper is going to be submitted to NIM).

This system will be used to characterize all the sensors employed in the Jlab Hall-B Forward Tagger Calorimeter foreseen for CLAS12.

Test results

- Two consecutive measurements have been done with the 2 APDs coupled to the same crystal and amplifier.
 - Small APD has been operated at intrinsic gain 200
 - Large Area APD has been operated at intrinsic gain 150
- Trigger was given by the scintillator telescope.
- Signals were acquired with FADCs (JLab-like) and integrated offline.

FADC signal

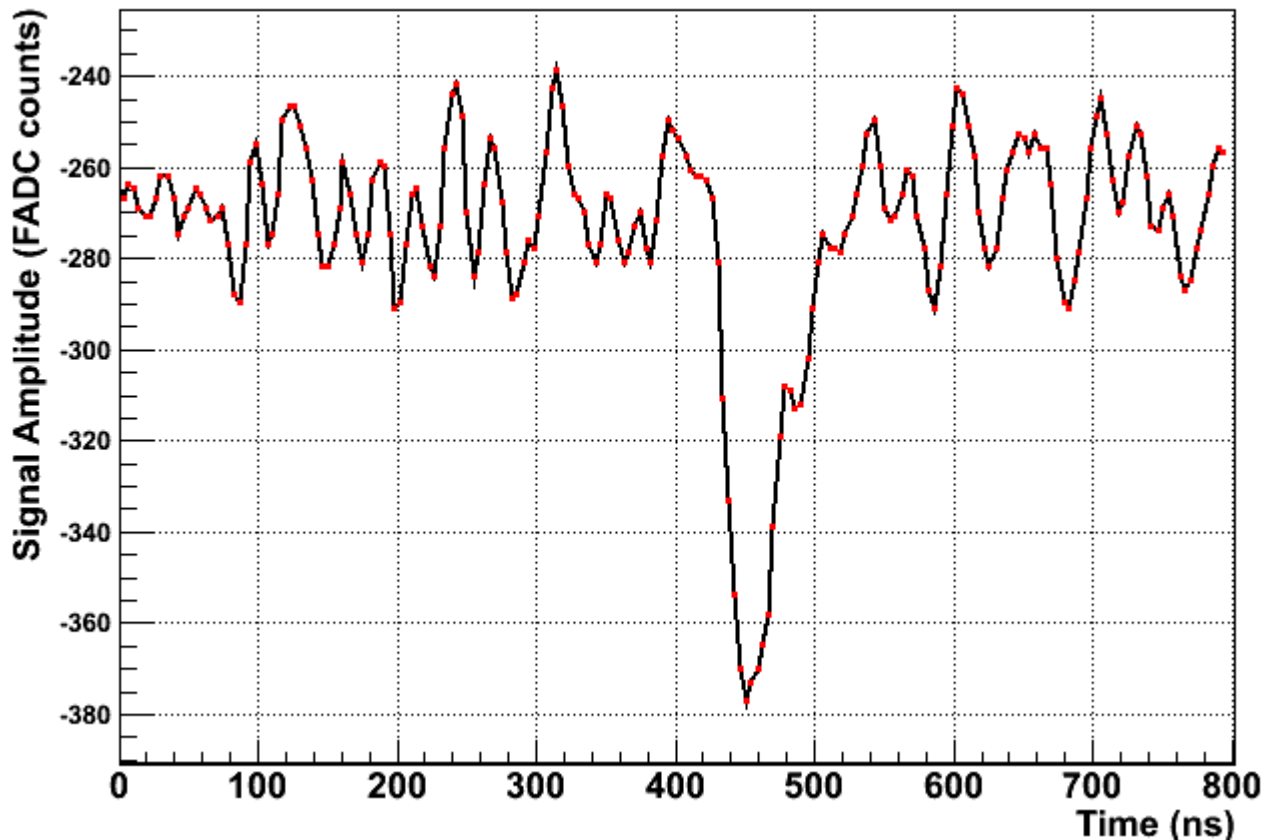

Signal recorded by FADC for one cosmic ray passing through the crystal (APD S8664-1010 large area).

1 FADC count = 0.4884 mV

Test results

- Red: charge distribution for all triggers coming from the scintillator telescope.
- Black: charge distribution for hits within 100 ns of the trigger signal.

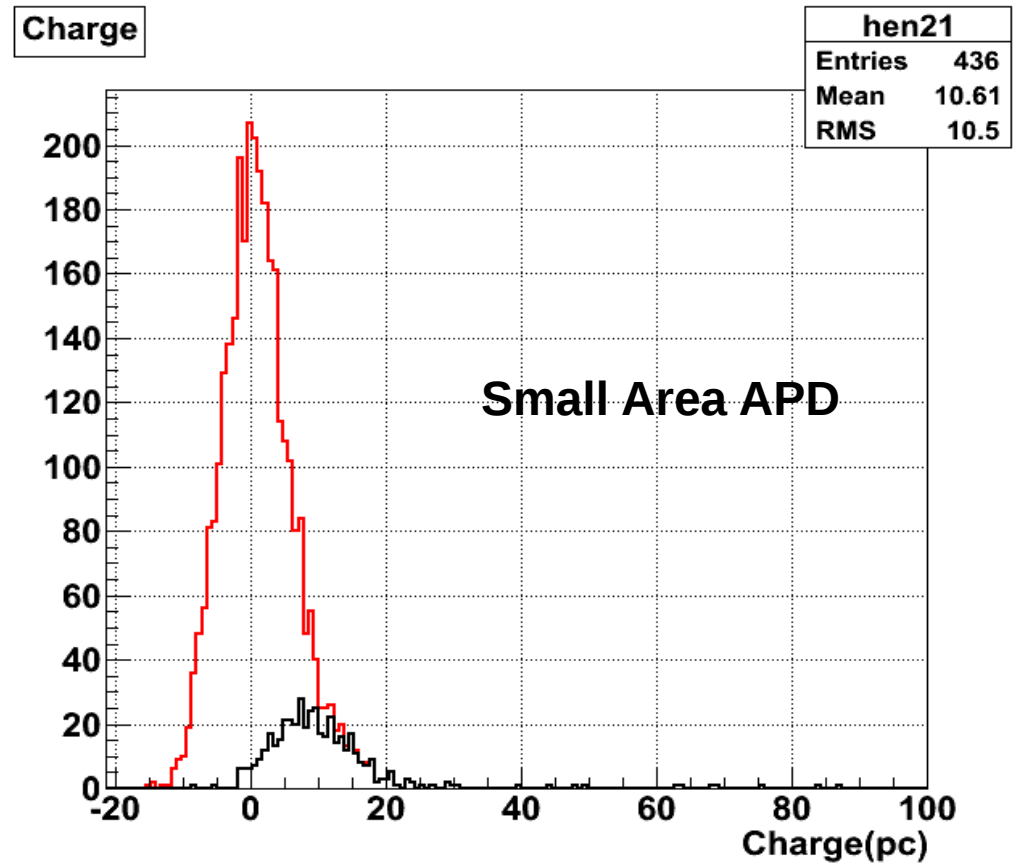
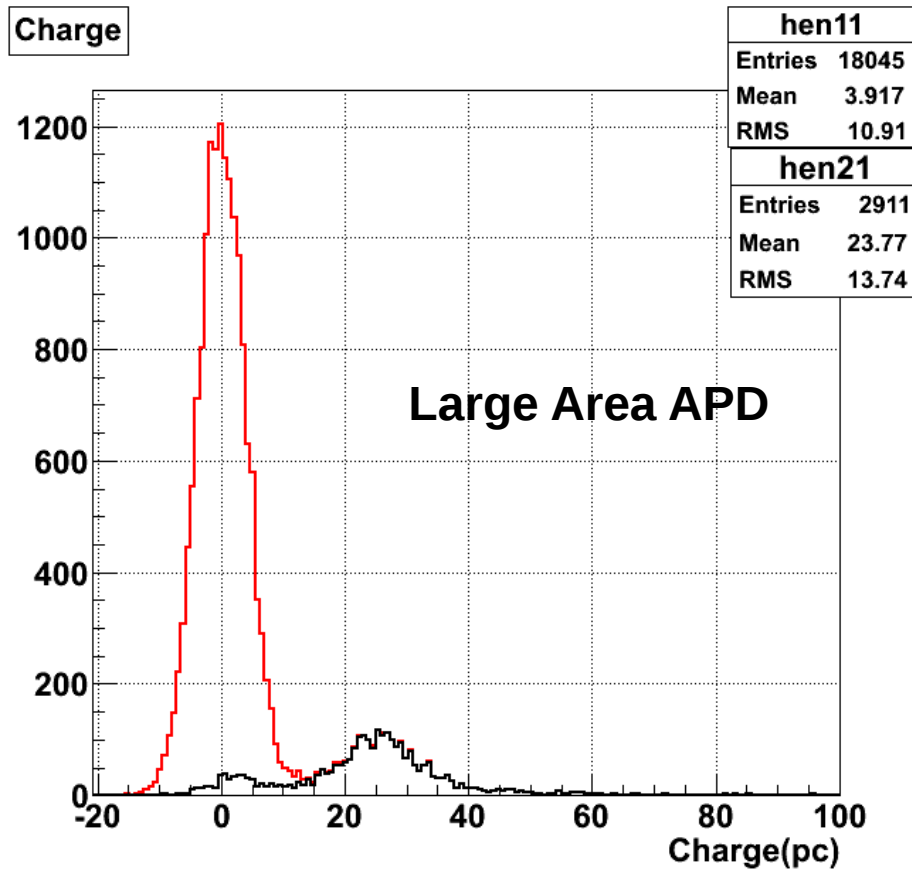

Conclusions

- A test has been performed to compare the existing APDs in the HPS ECAL (Hamamatsu S8664-55) with new large-area model (S8664-1010) when coupled to PbWO₄ crystal exposed to cosmic rays.
- The assembly has been put in a thermal box. Stability during the test was better than 0.1 deg.
- A new modified amplifier, with reduced noise, has been employed for both cases.
- For the new S8664-1010 APD the MIP peak is clearly visible and well-isolated from background, while with the S8664-55 the MIP is seen but its distribution is under the noise peak and does not have well-defined position.

Backup-1

Charge distribution VS hit-time

