

SHEET=2

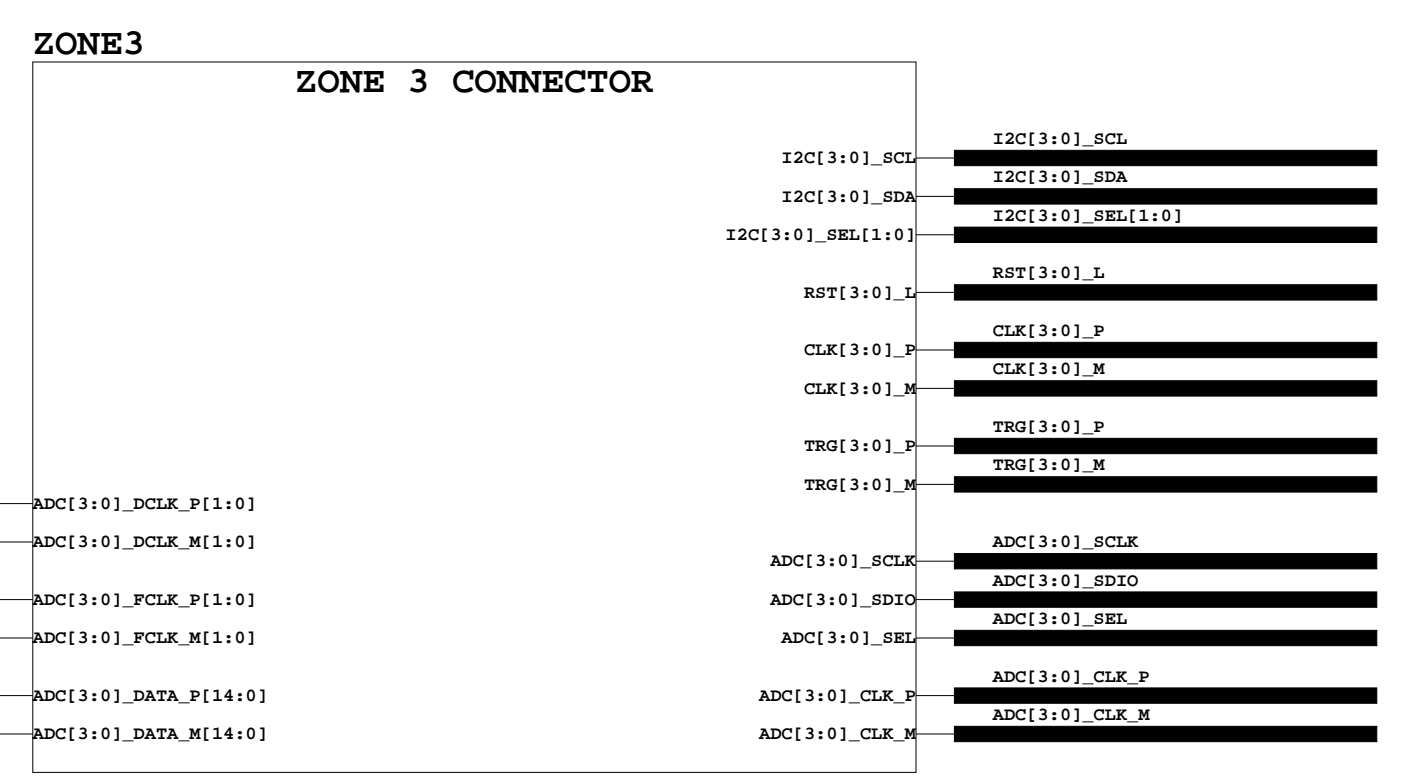

SHEET=23

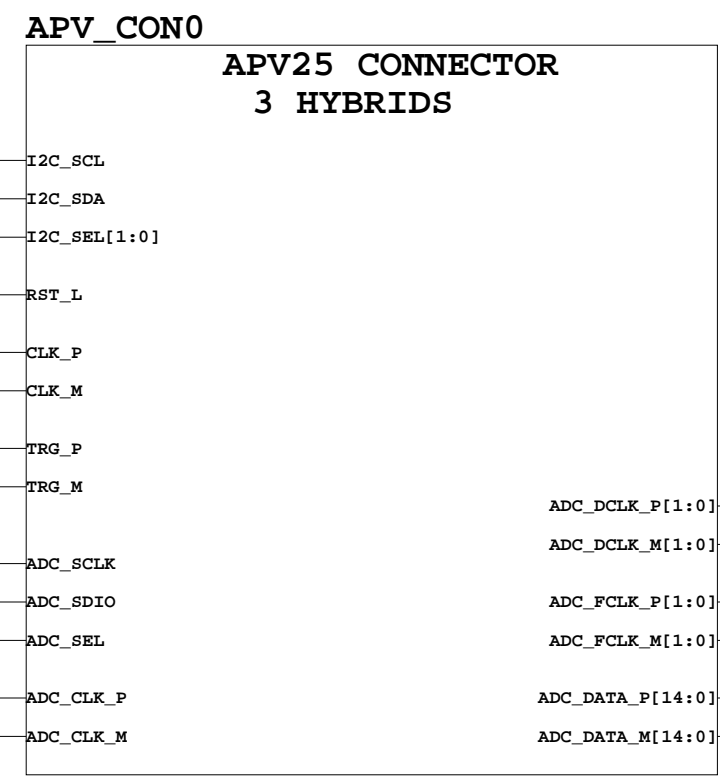
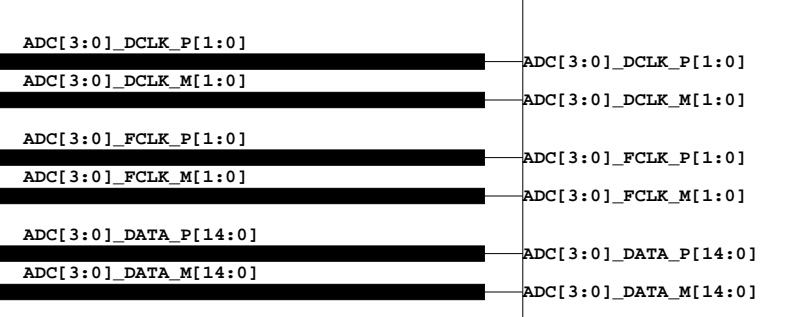

SHEET=3

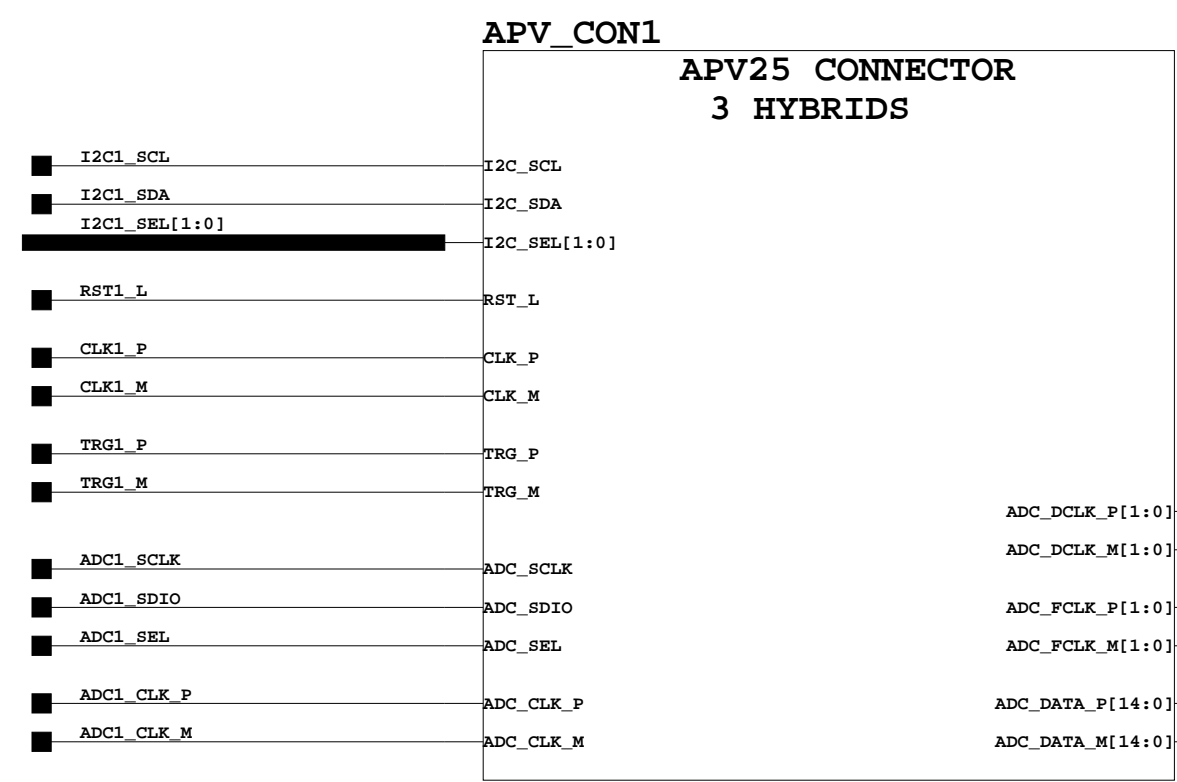

SHEET=8

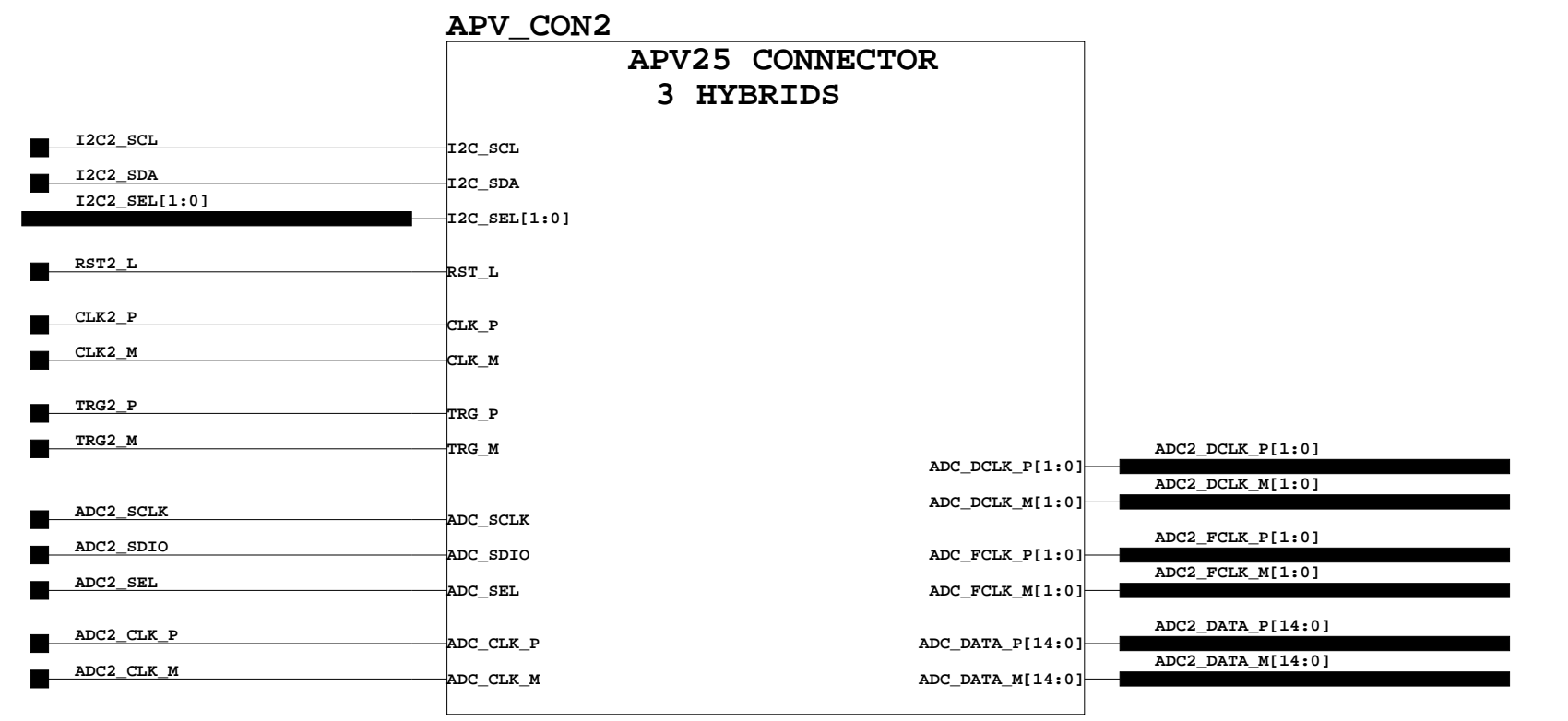

SHEET=13

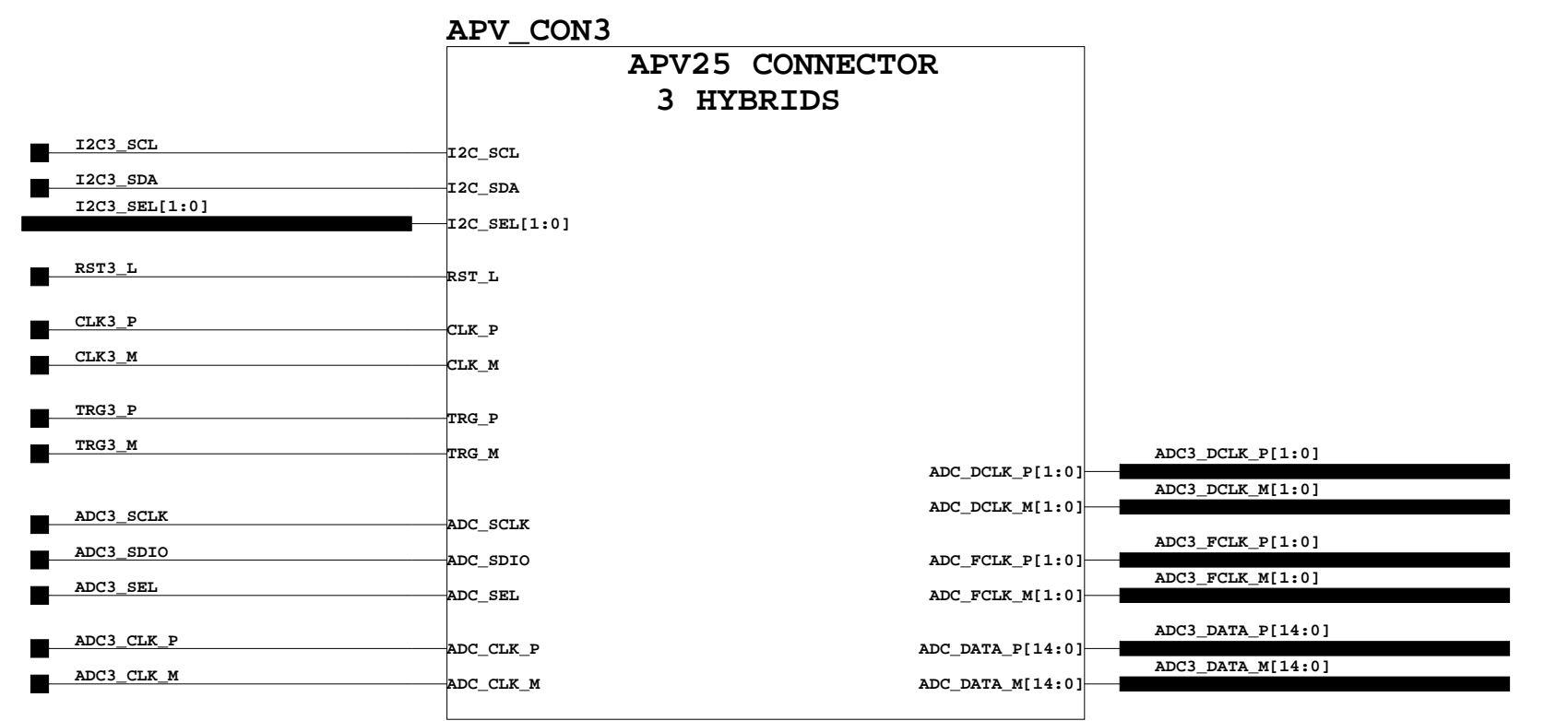

SHEET=18

4-11-2011_15:40

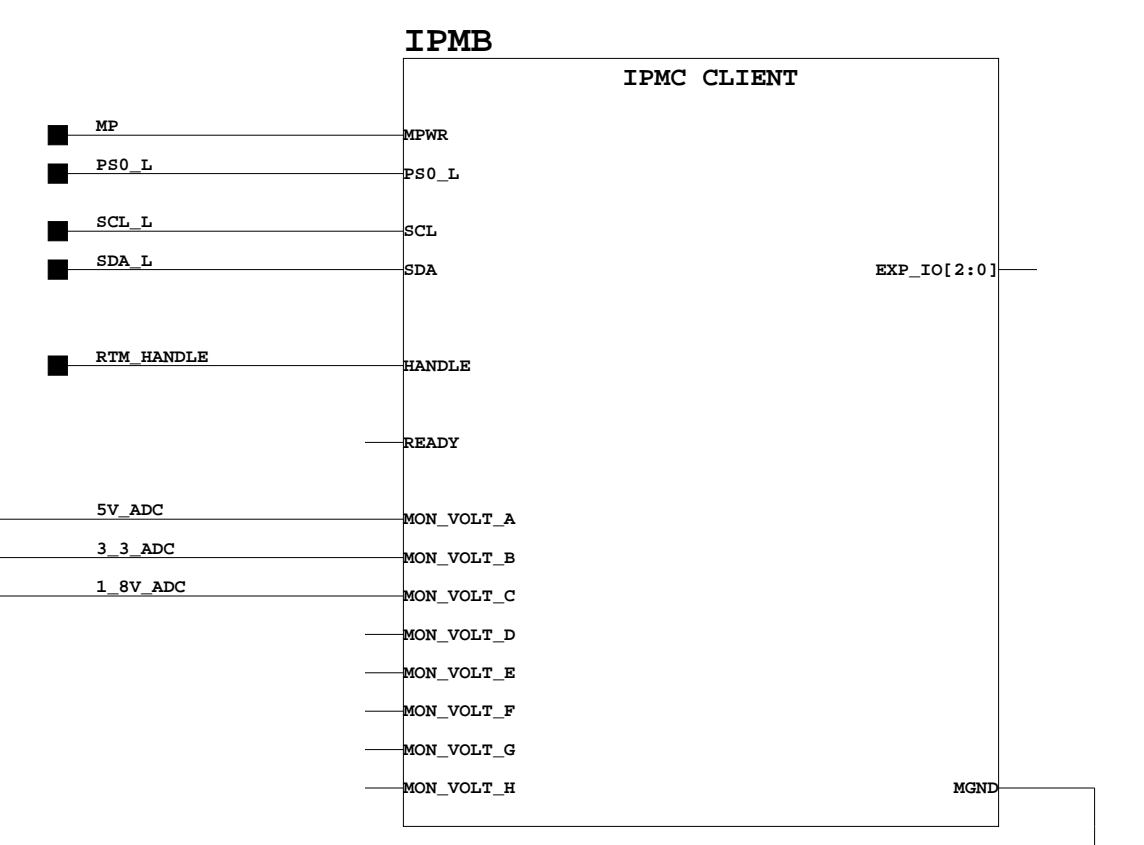
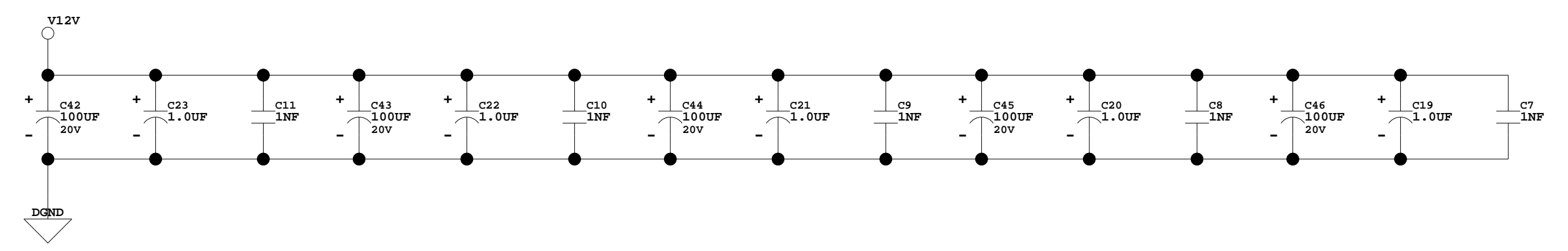
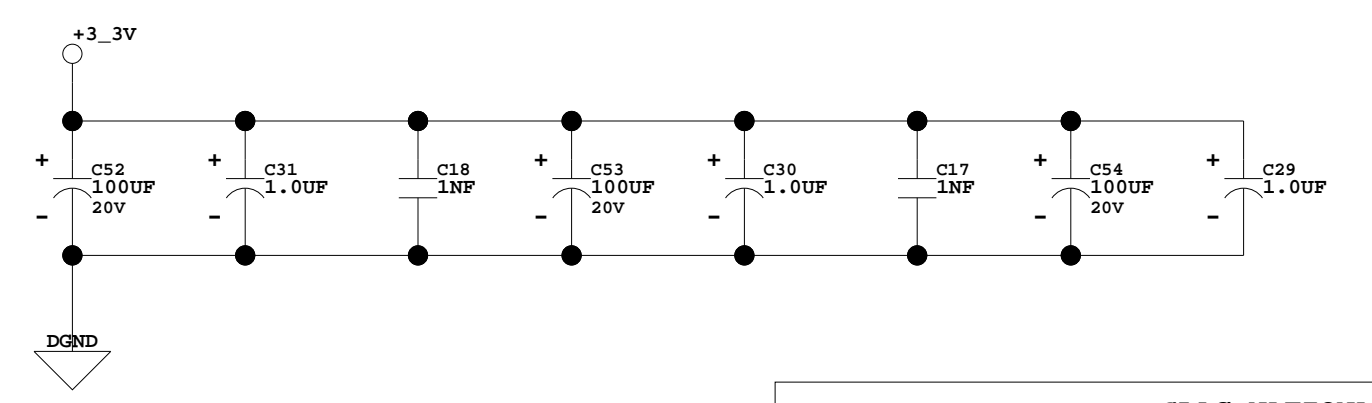
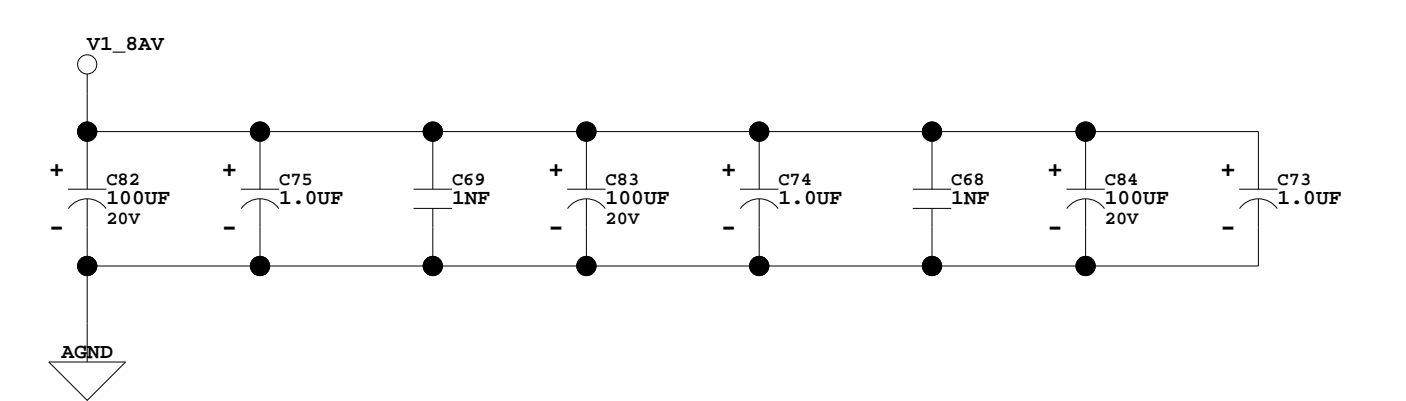
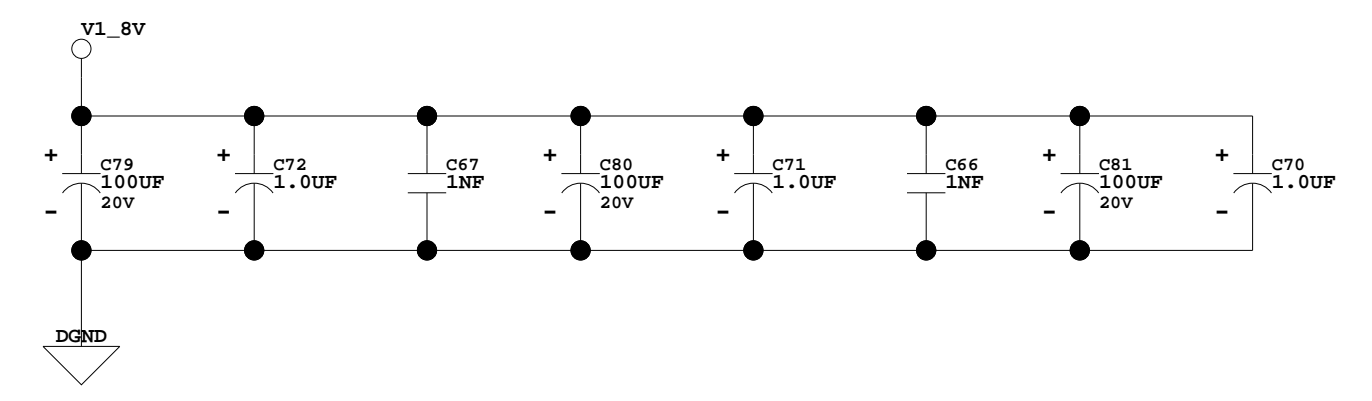
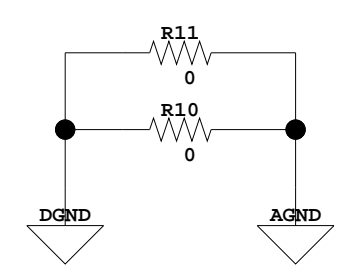
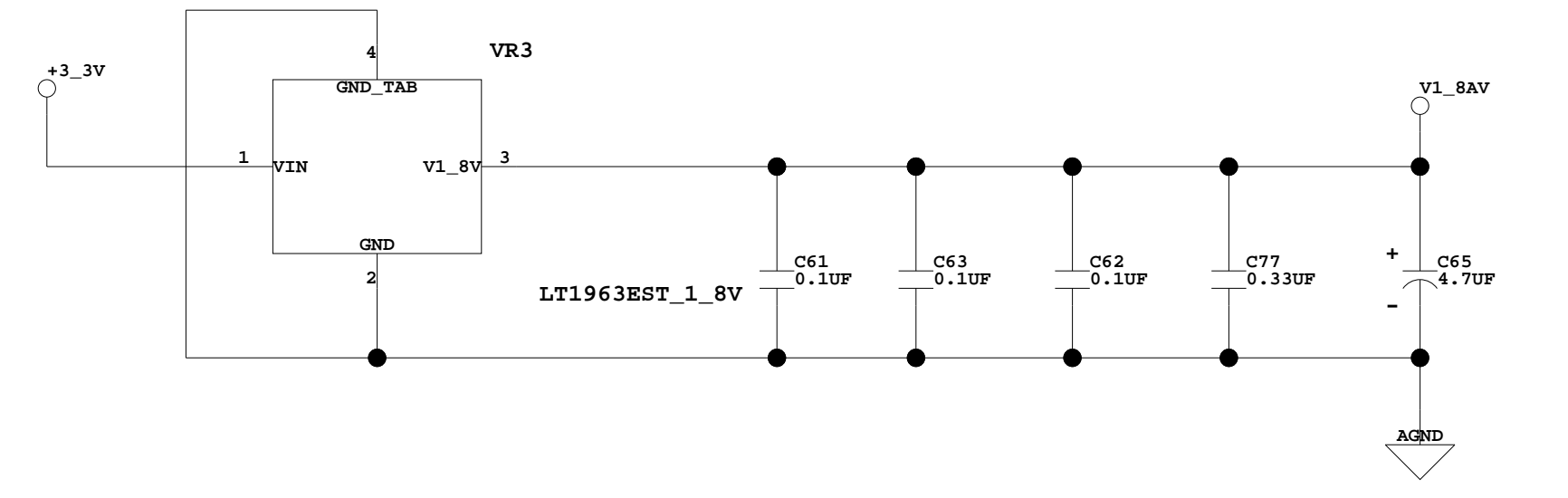
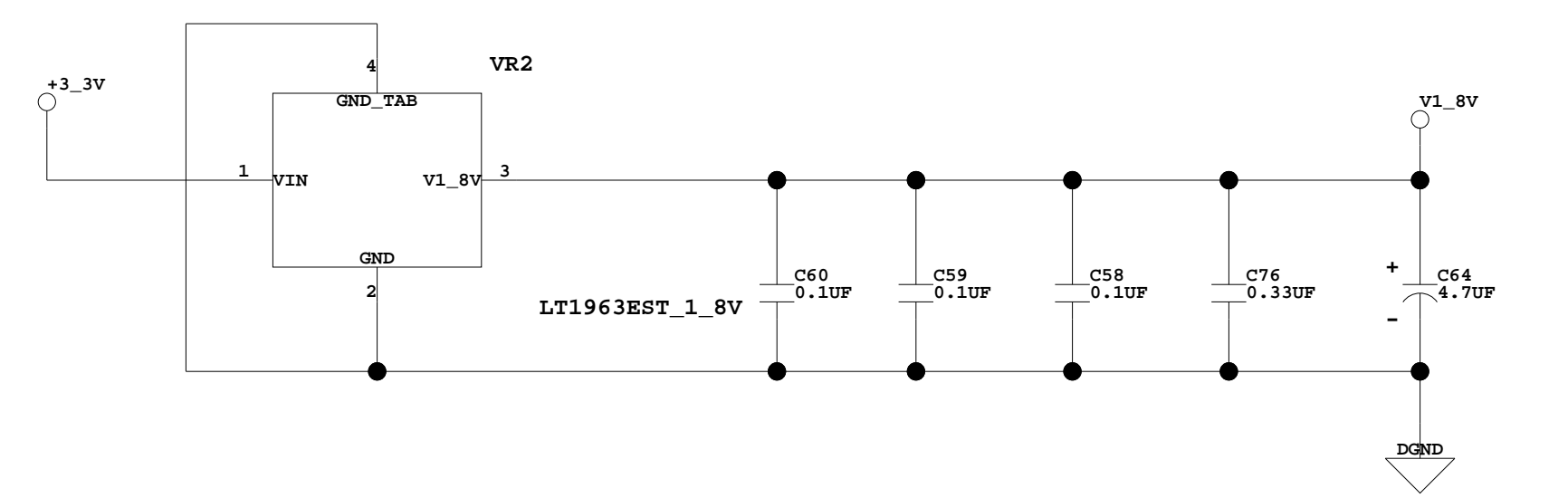
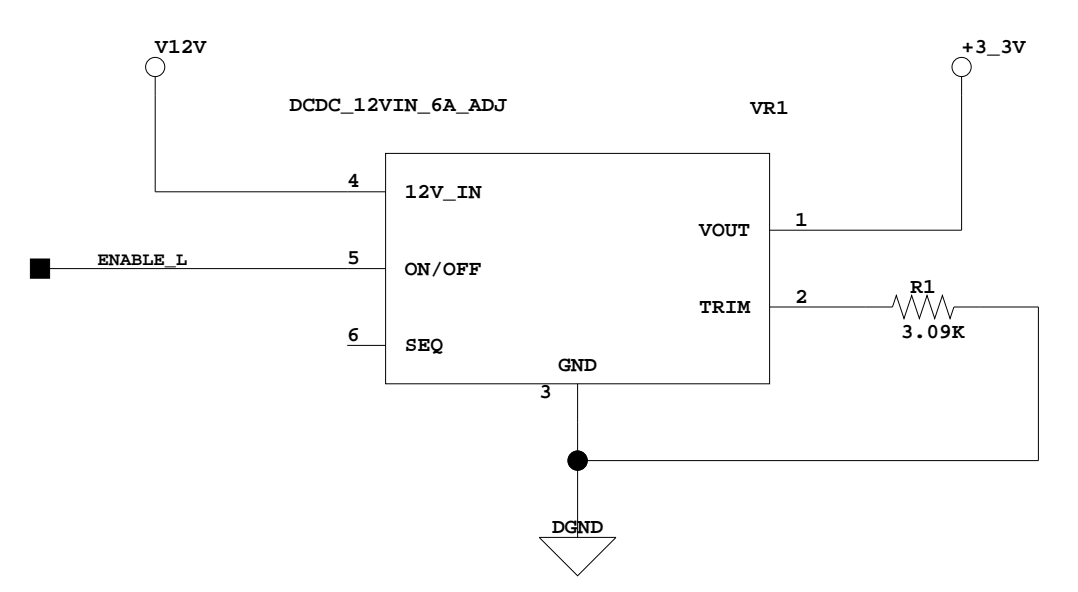
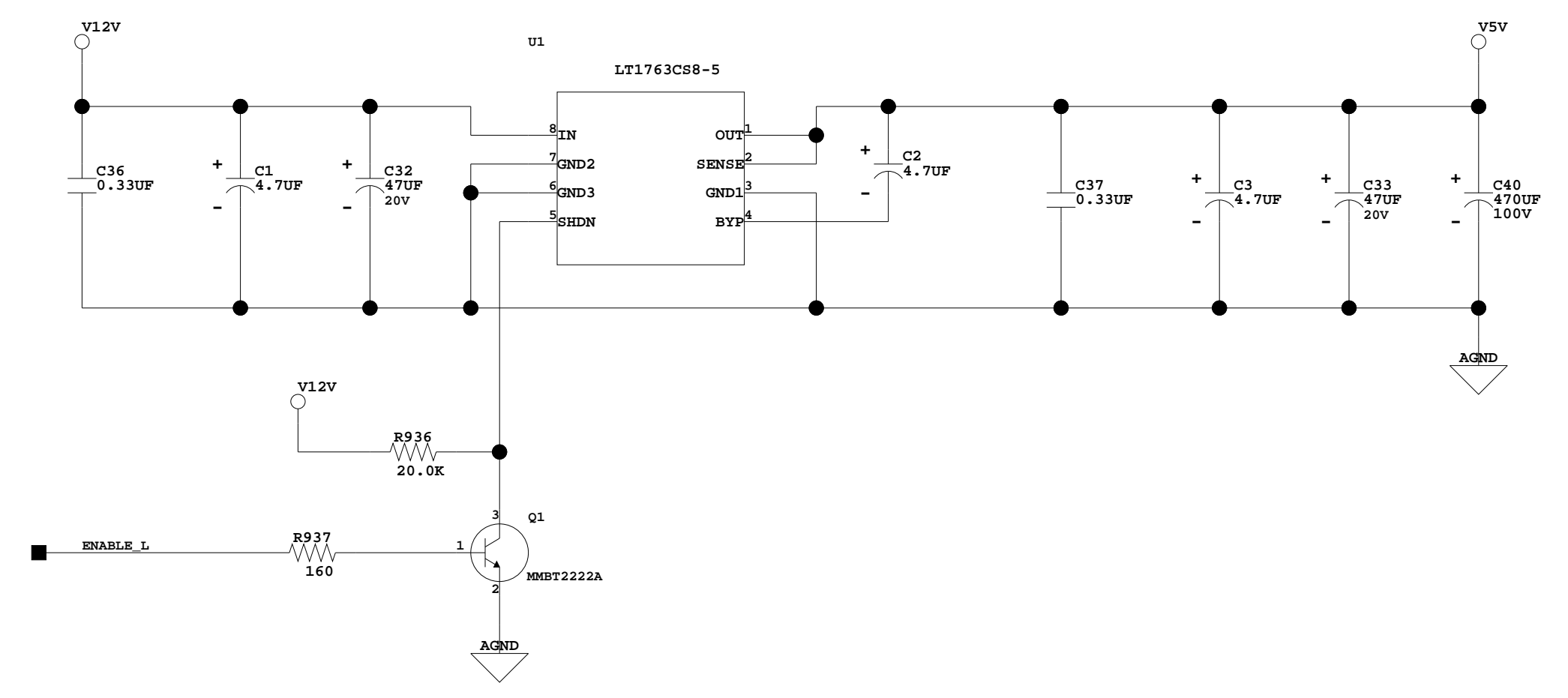
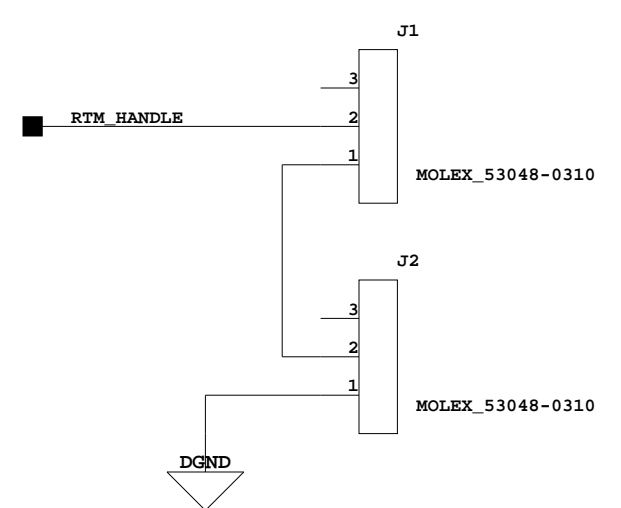
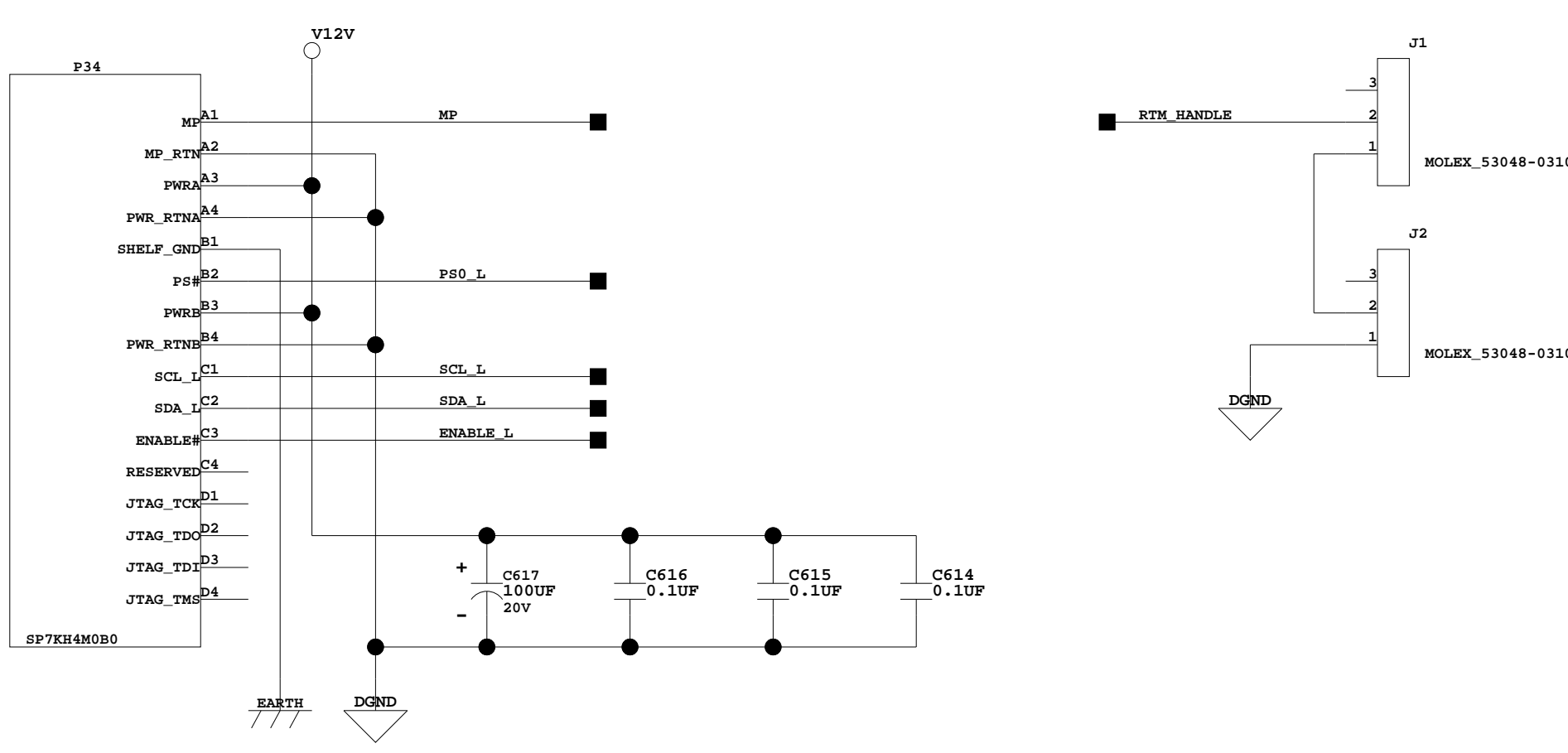

SLAC NATIONAL ACCELERATOR LABORATORY
U.S. DEPARTMENT OF ENERGY

STANFORD UNIVERSITY STANFORD, CALIFORNIA

PROPRIETARY DATA OF STANFORD UNIVERSITY AND/OR U.S. DEPARTMENT OF ENERGY. RECIPIENT SHALL NOT PUBLISH THE INFORMATION WITHIN UNLESS GRANTED SPECIFIC PERMISSION OF STANFORD UNIVERSITY.

INGR	DATE	APPROVALS
DFR	2010	
CDR		

SHEET 2 OF 23

HEAVY P TRACKER READOUT RTM
POWER REGULATORS

LOCATED AT SHEET 1

SD-249-901-02-C01

4-11-2011_15:42

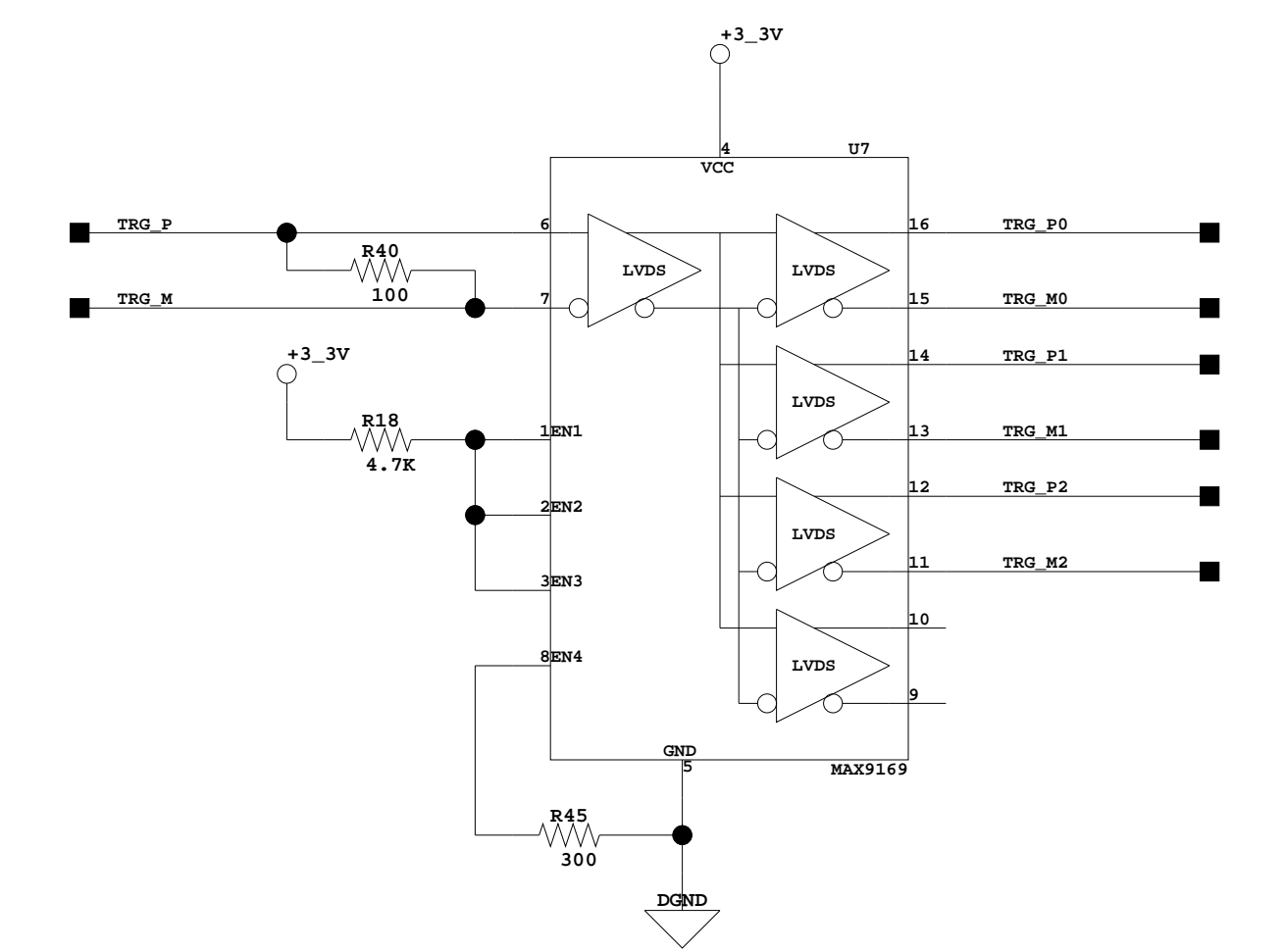
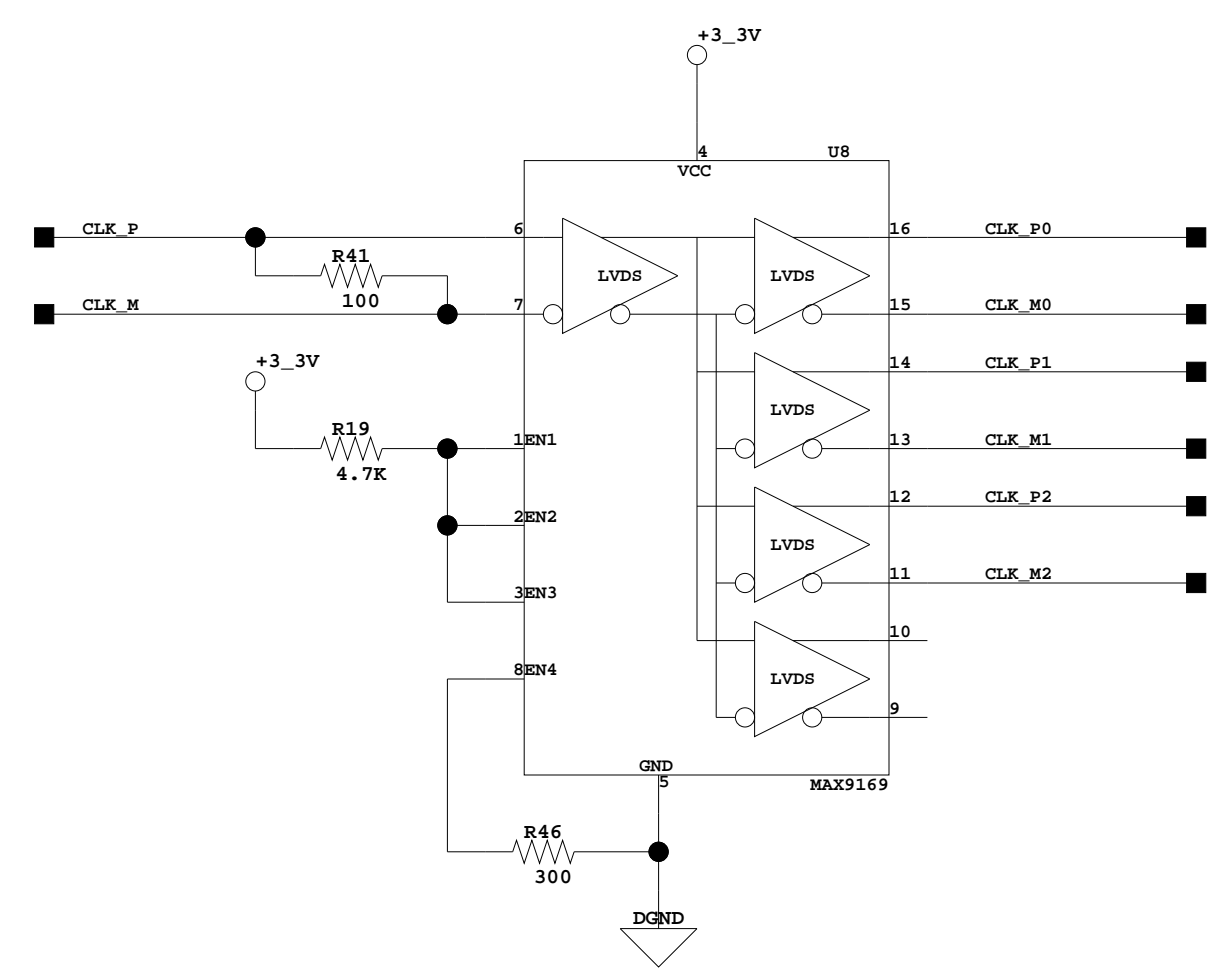
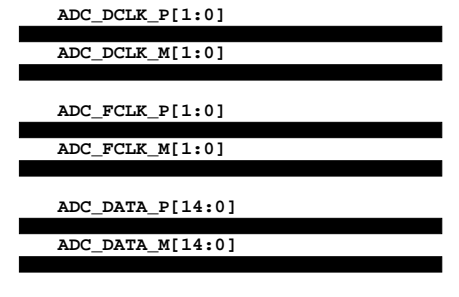
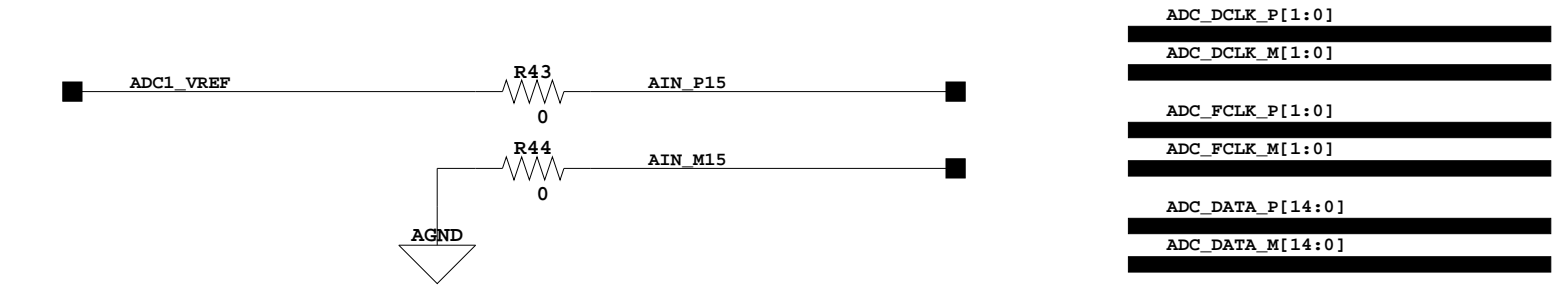
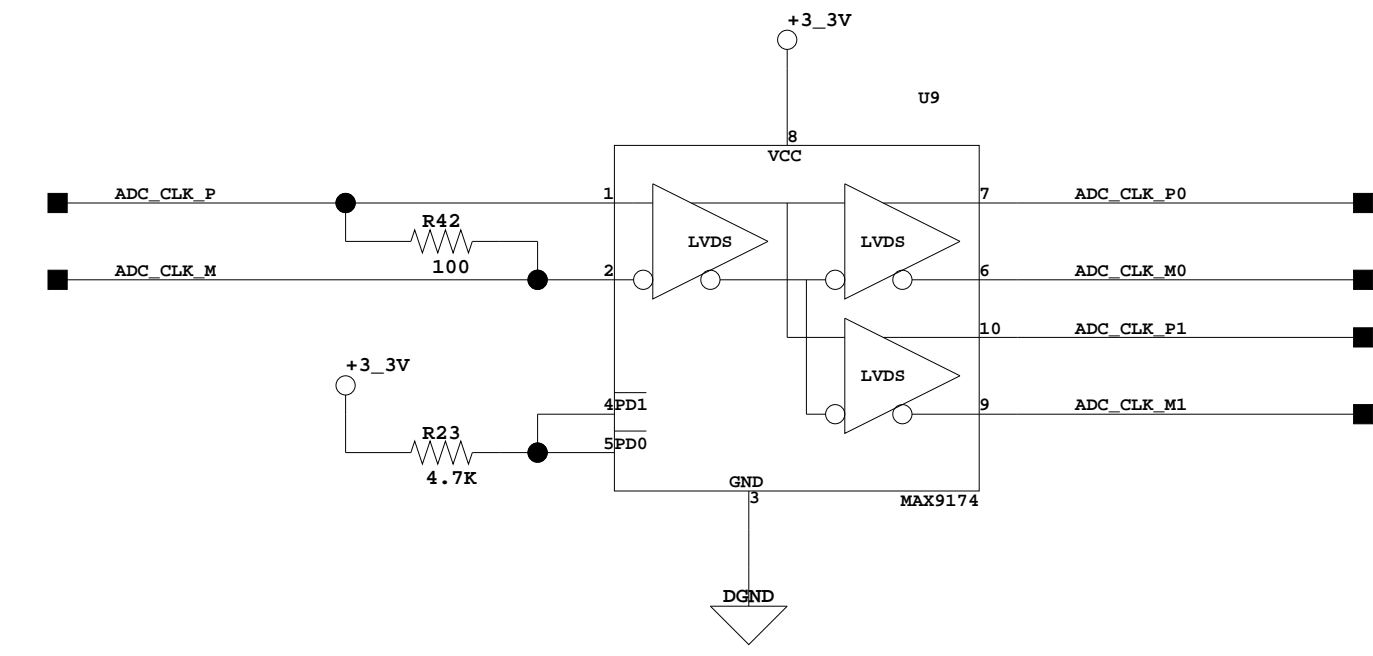
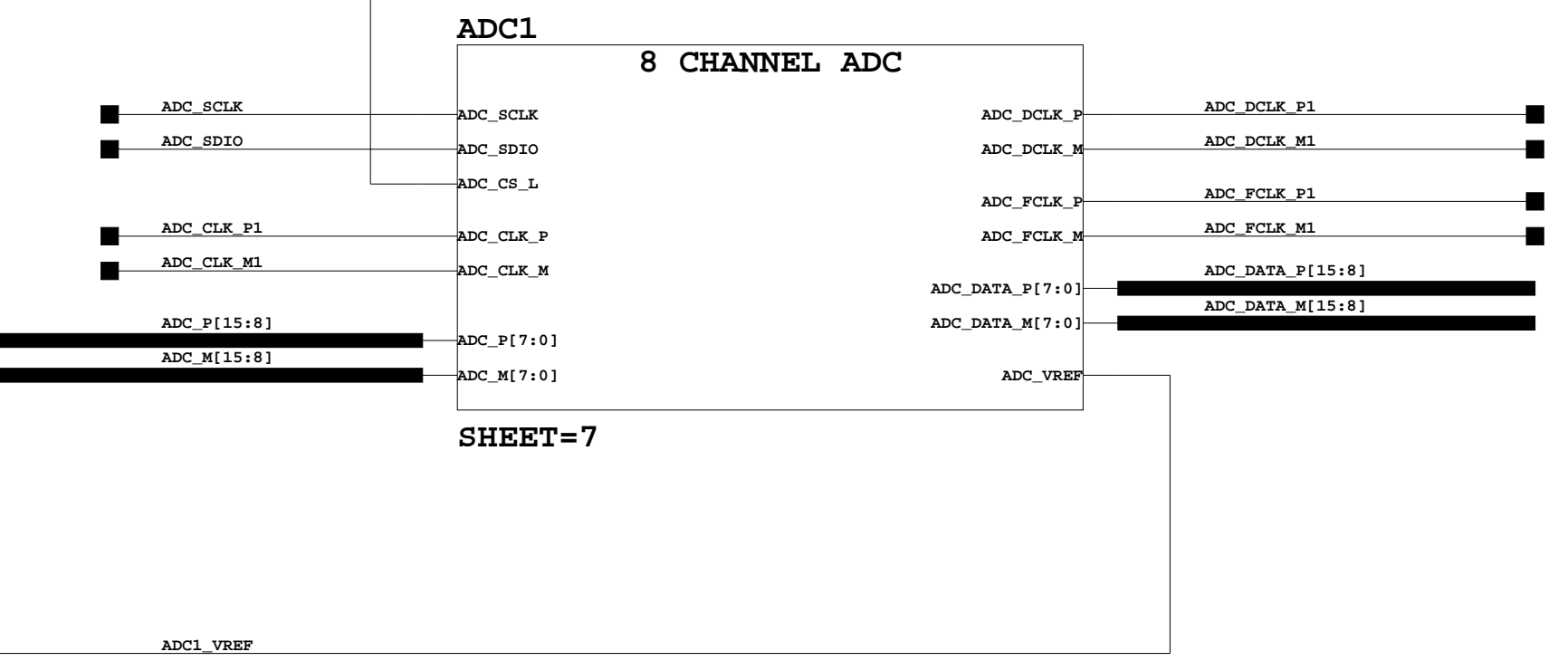
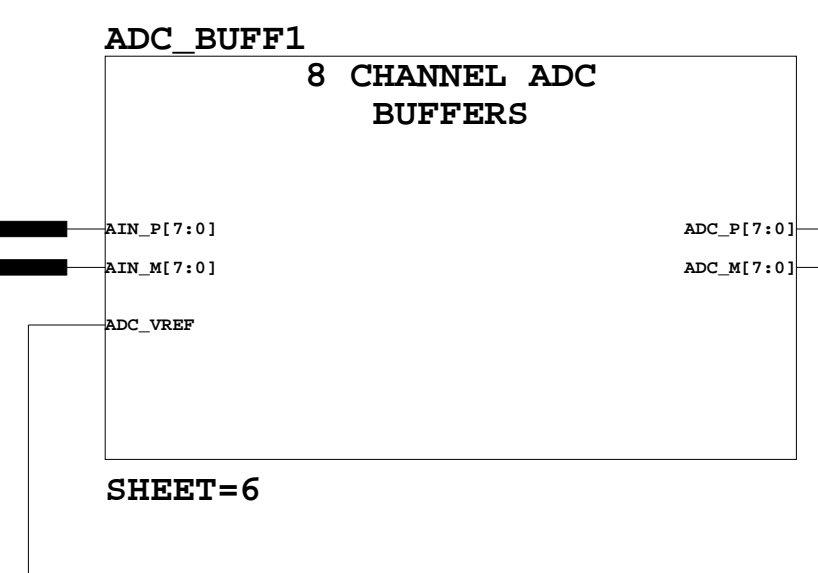
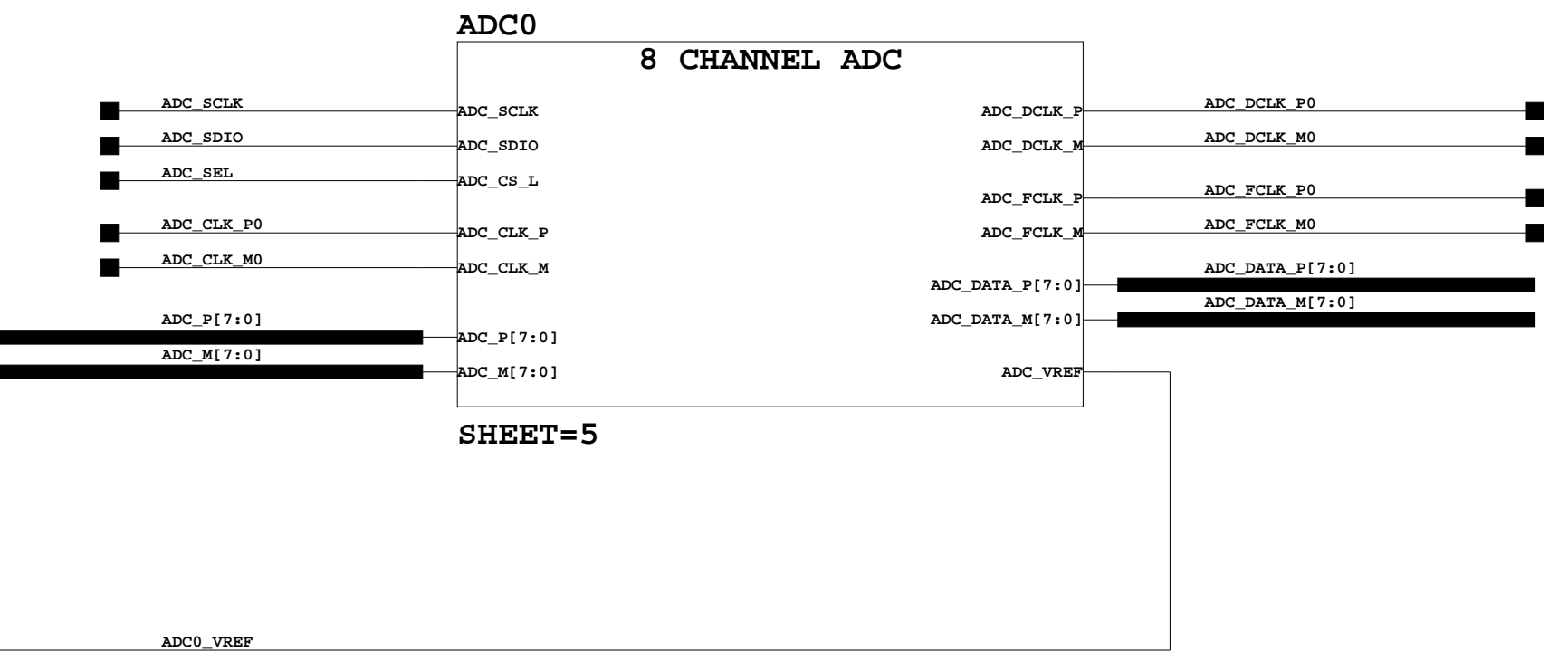
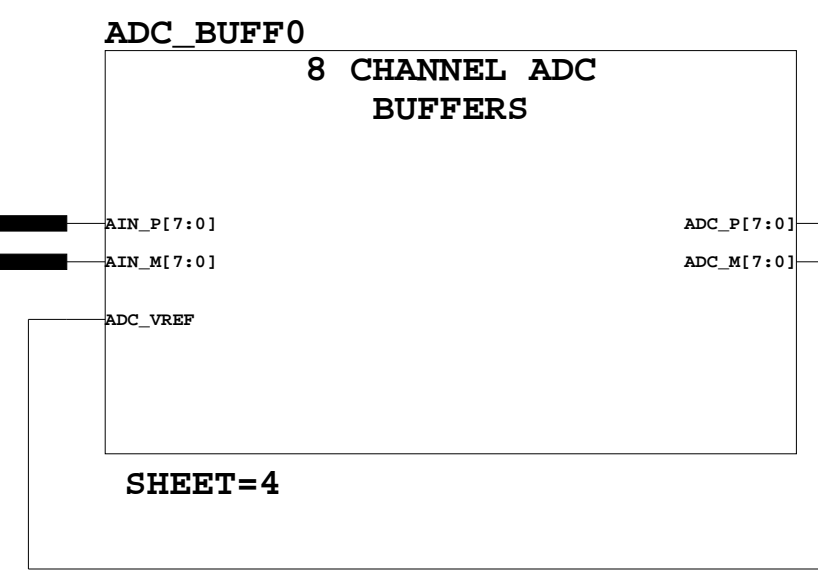
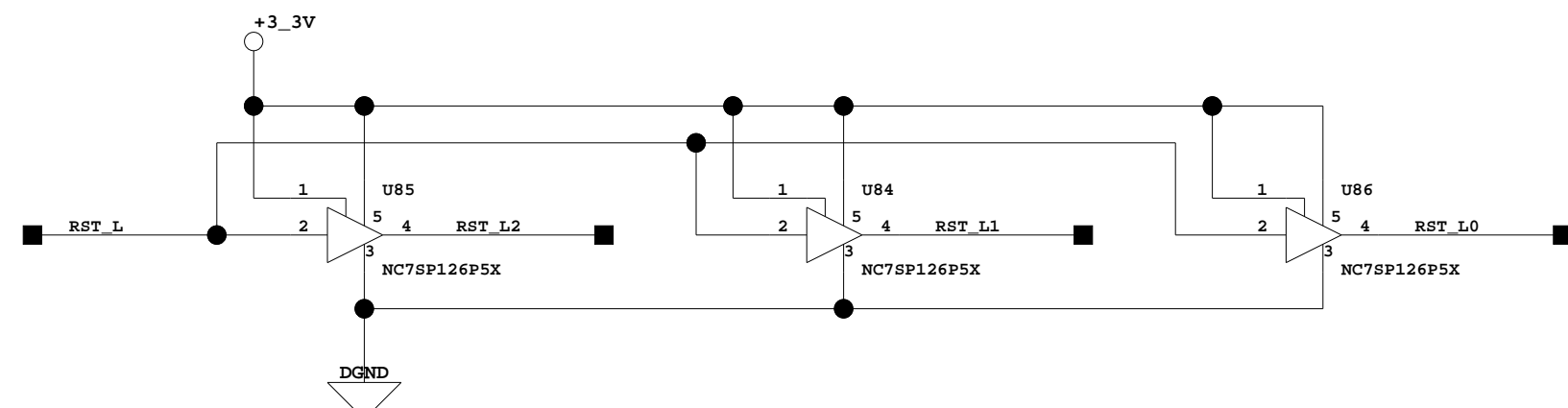
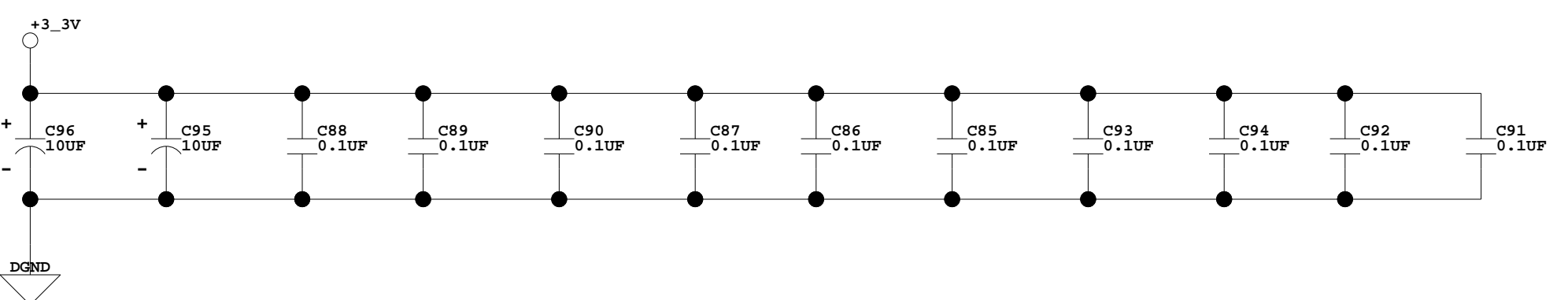
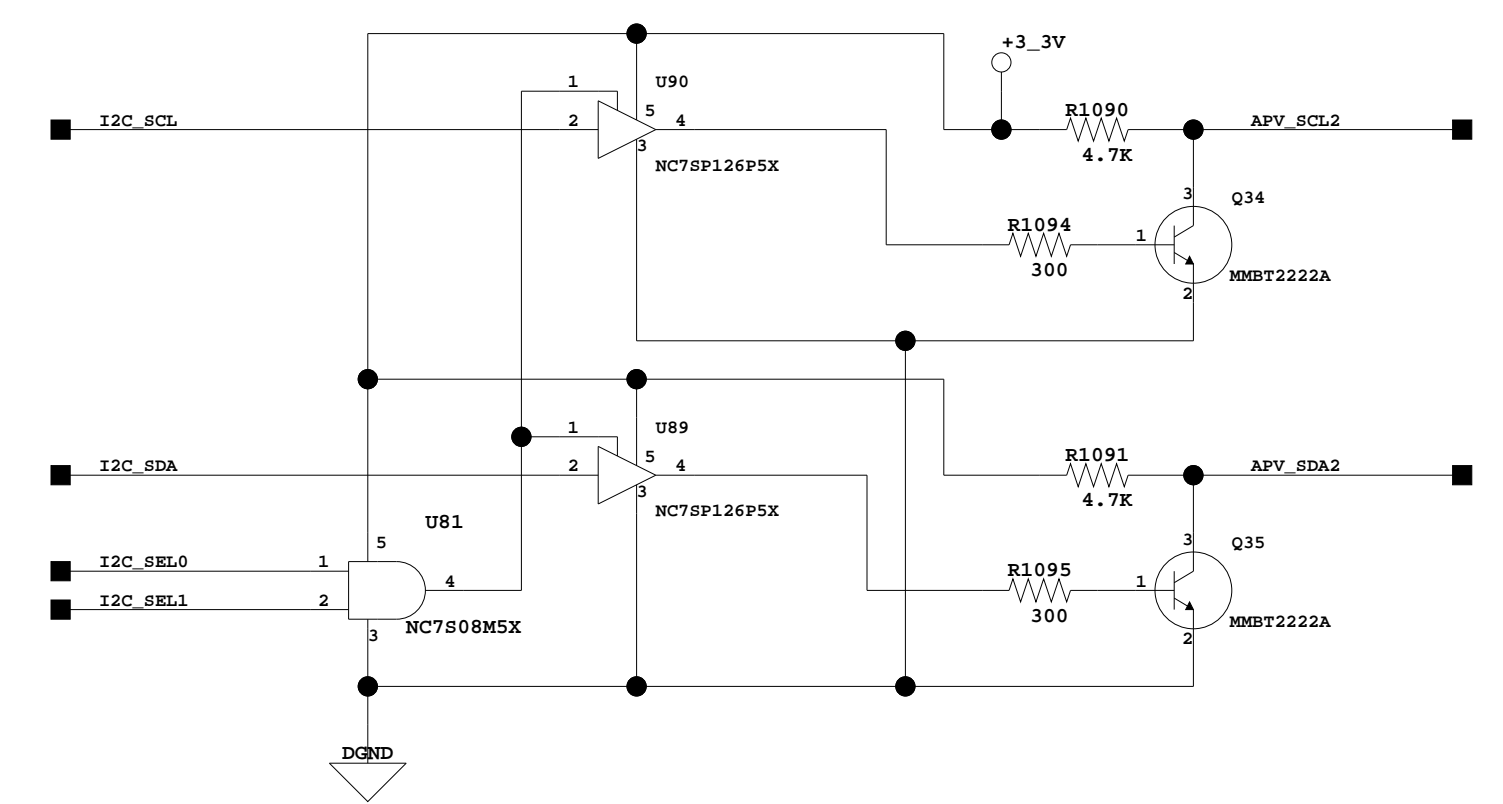
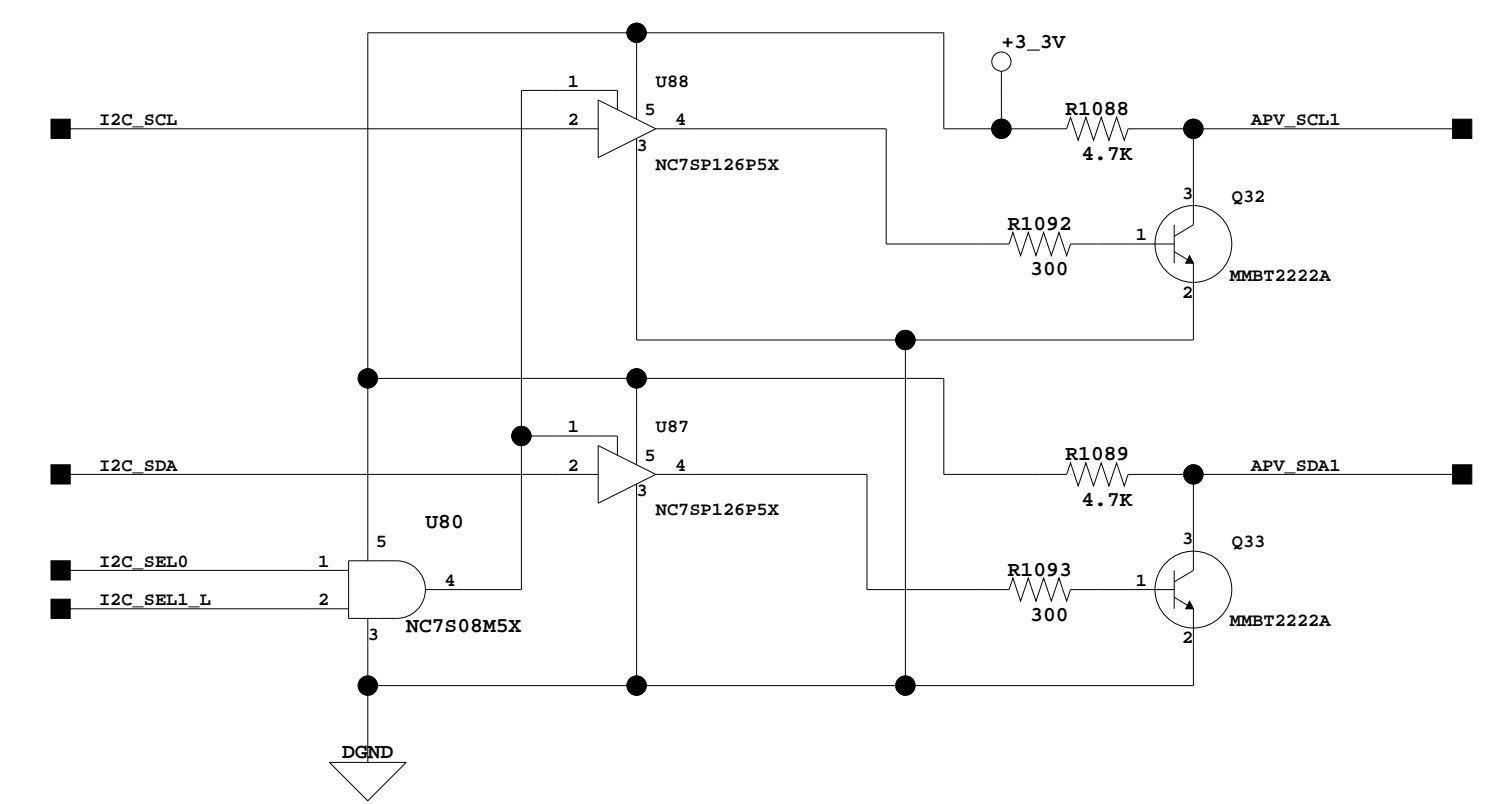
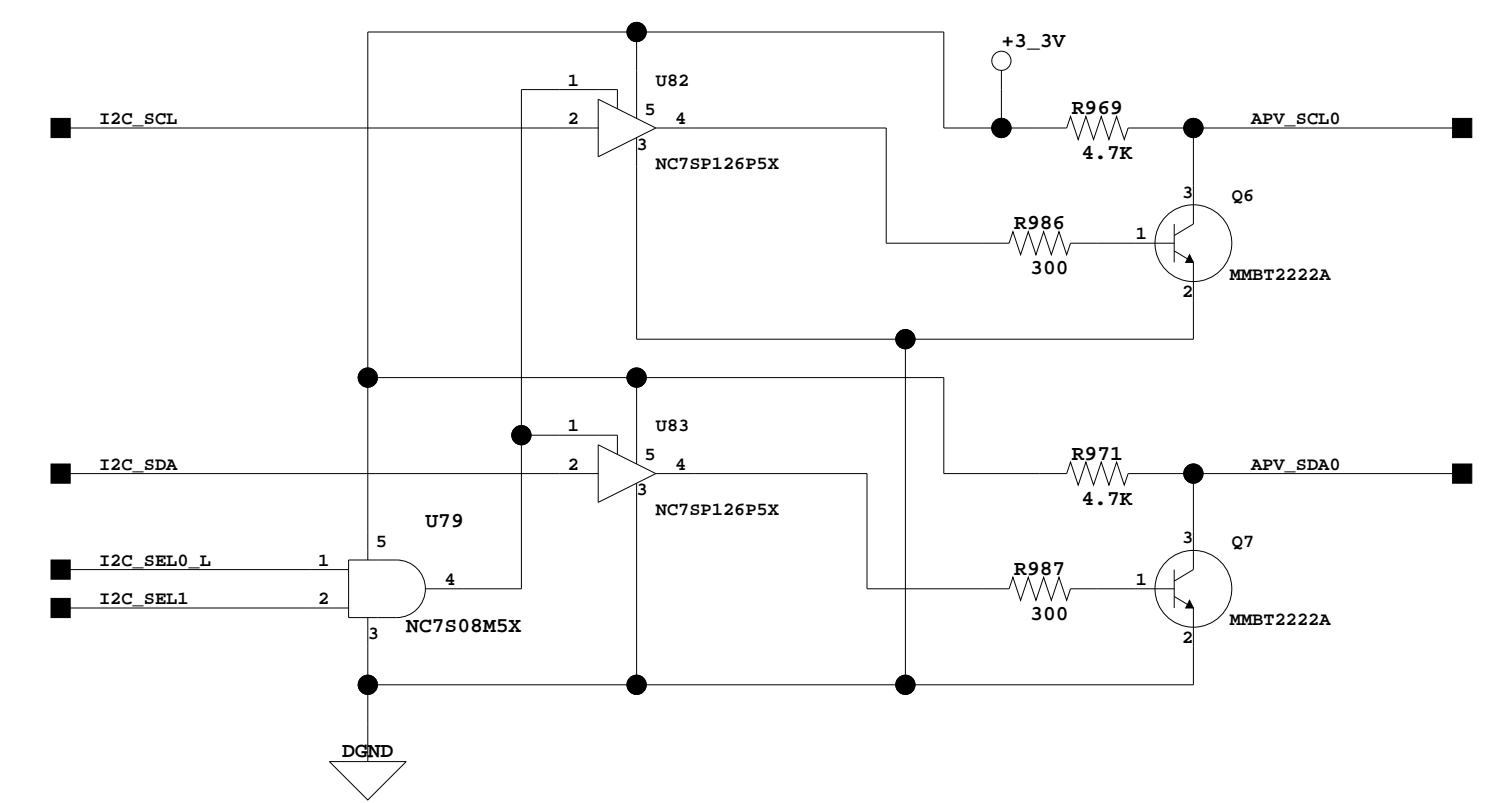
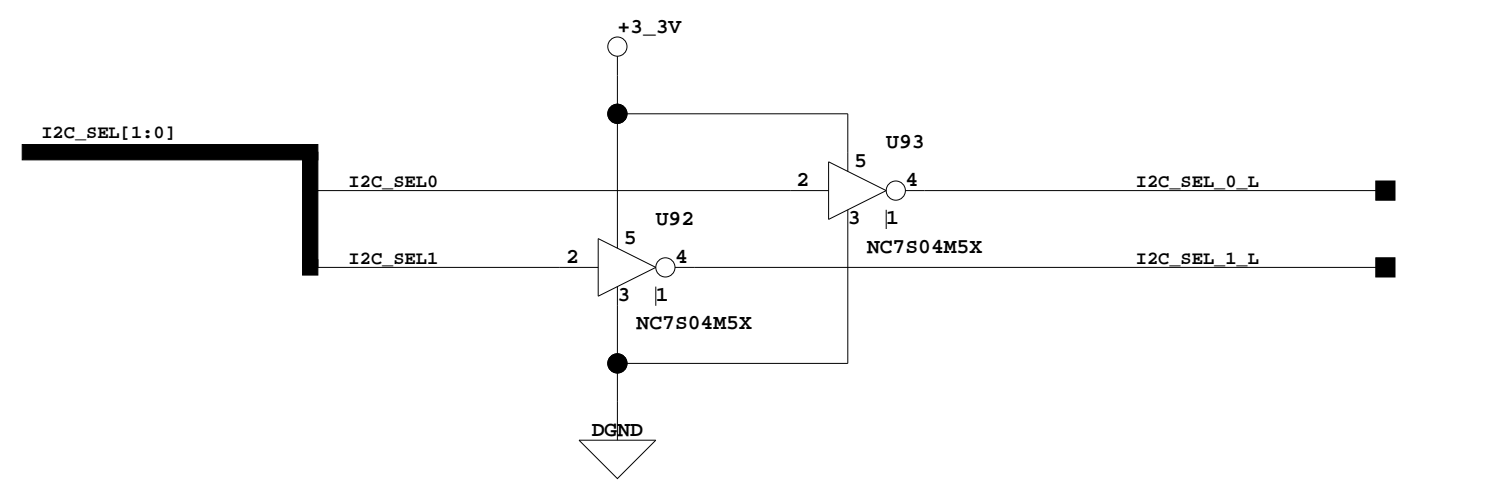
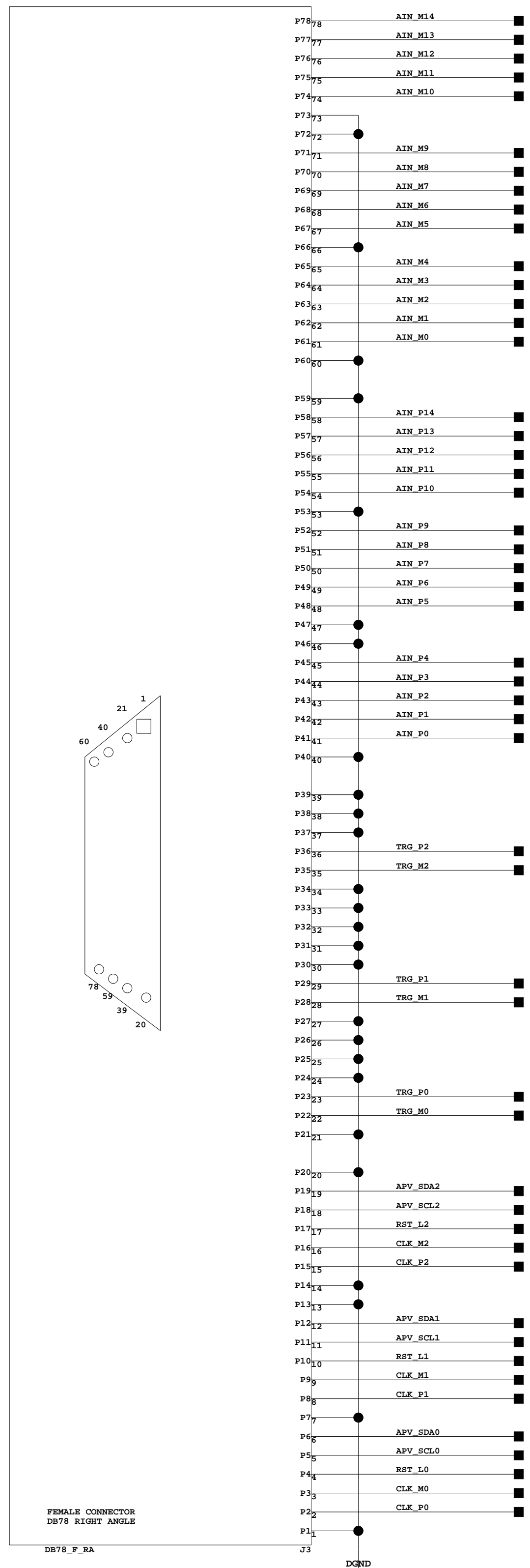

SLAC NATIONAL ACCELERATOR LABORATORY
U.S. DEPARTMENT OF ENERGY

STANFORD UNIVERSITY STANFORD, CALIFORNIA

PROPRIETARY DATA OF STANFORD UNIVERSITY AND/OR U.S. DEPARTMENT OF ENERGY. RECIPIENT SHALL NOT PUBLISH THE INFORMATION WITHIN UNLESS GRANTED SPECIFIC PERMISSION OF STANFORD UNIVERSITY.

DATE	APPROVALS
2010	Ryan Herbst

SHEET 3 OF 23

HEAVY P TRACKER READOUT RTM
APV25 CONNECTOR

LOCATED AT SHEET 1
SD-249-901-02-C01

4-11-2011_15:42

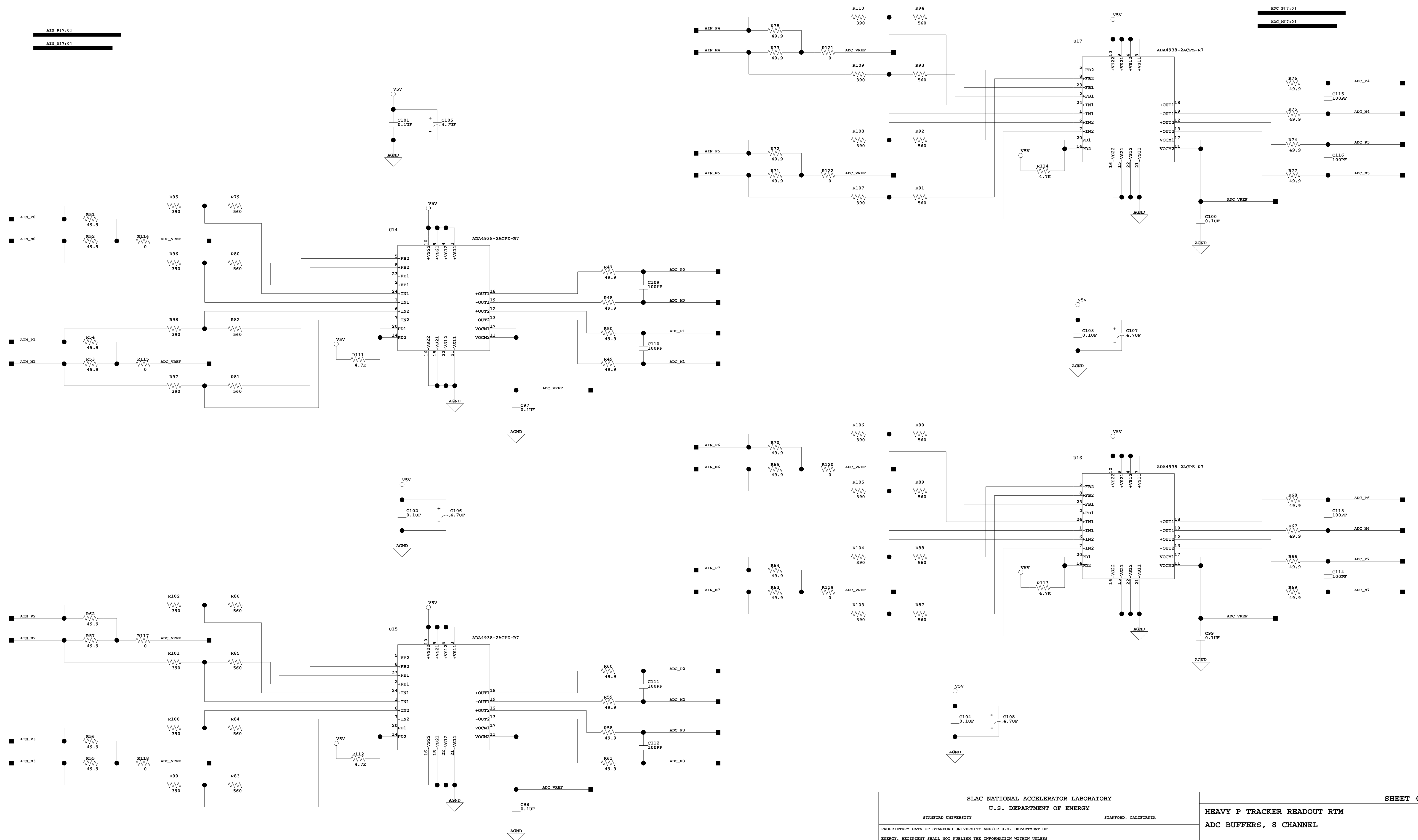

AIN_P[7:0]
AIN_M[7:0]

ADC_P[7:0]
ADC_M[7:0]

SLAC NATIONAL ACCELERATOR LABORATORY U.S. DEPARTMENT OF ENERGY		
STANFORD UNIVERSITY	STANFORD, CALIFORNIA	
PROPRIETARY DATA OF STANFORD UNIVERSITY AND/OR U.S. DEPARTMENT OF ENERGY. RECIPIENT SHALL NOT PUBLISH THE INFORMATION WITHIN UNLESS GRANTED SPECIFIC PERMISSION OF STANFORD UNIVERSITY.		
INCR	DATE	APPROVALS
DFR	2010	
CDR		

SHEET 4 OF 23

**HEAVY P TRACKER READOUT RTM
ADC BUFFERS, 8 CHANNEL**

LOCATED AT SHEET 3

SD-249-901-02-C01

1-24-2011_15:38

**ADC INPUT TERMINATION
PLACE NEAR ADC**

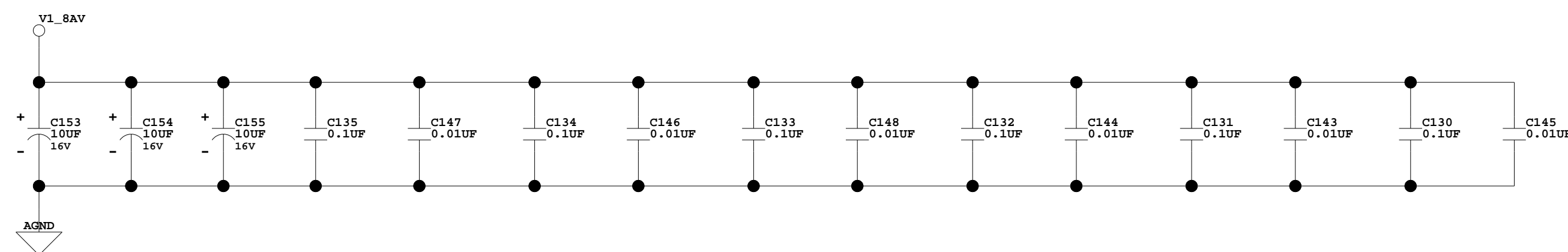
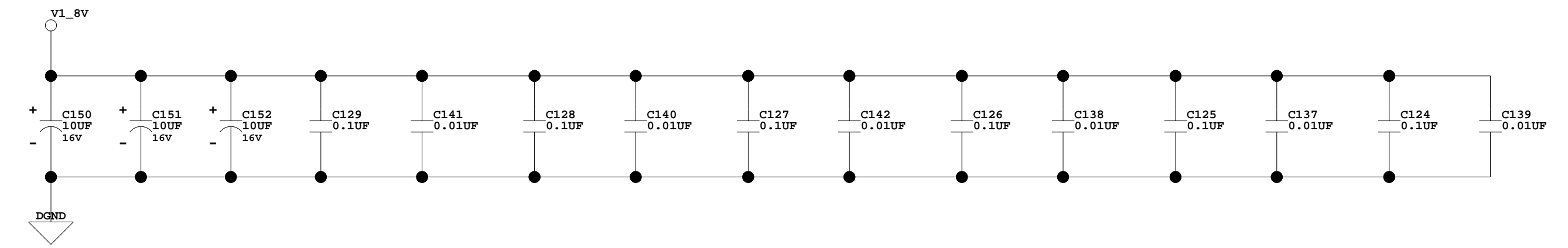
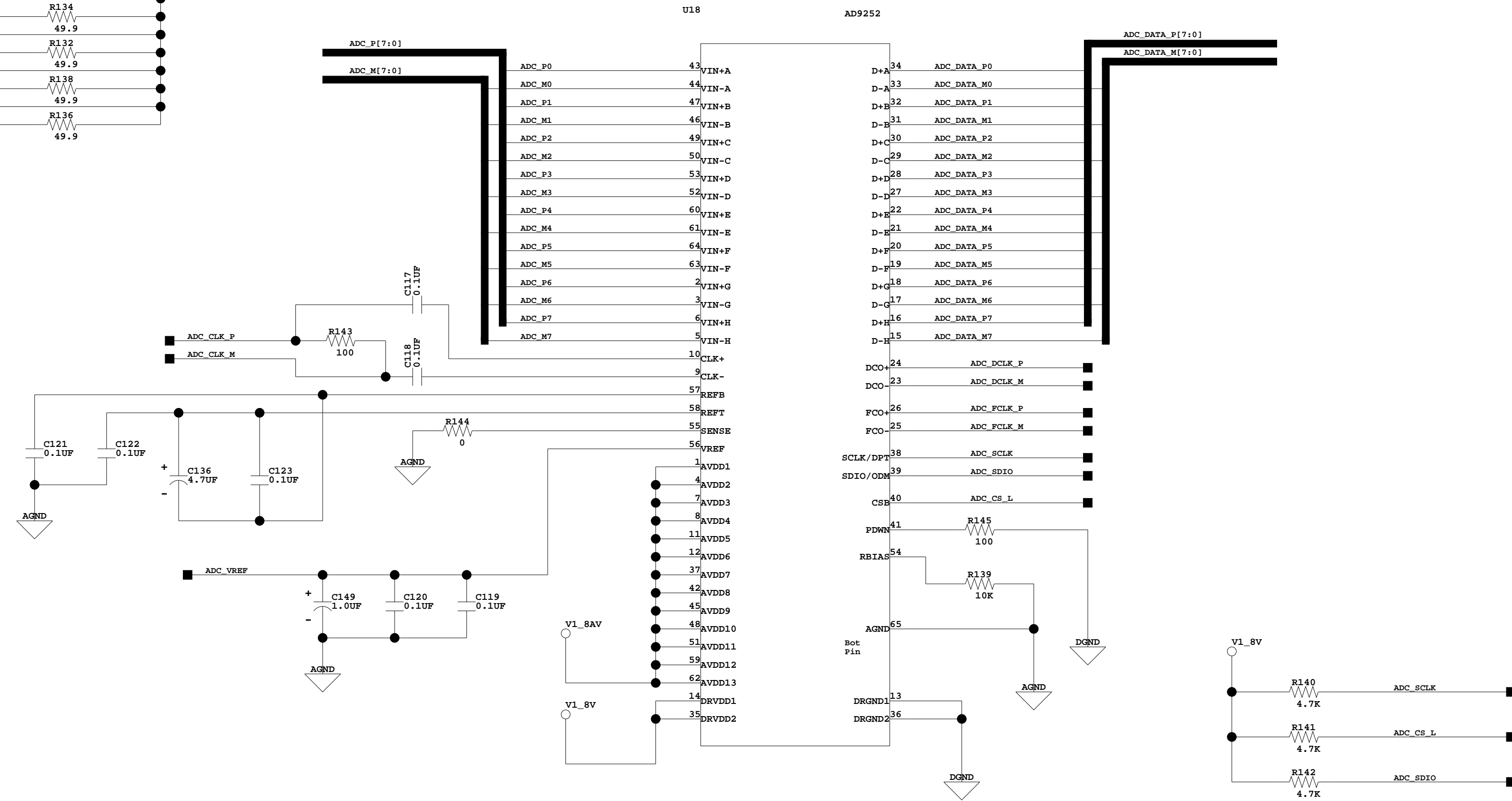
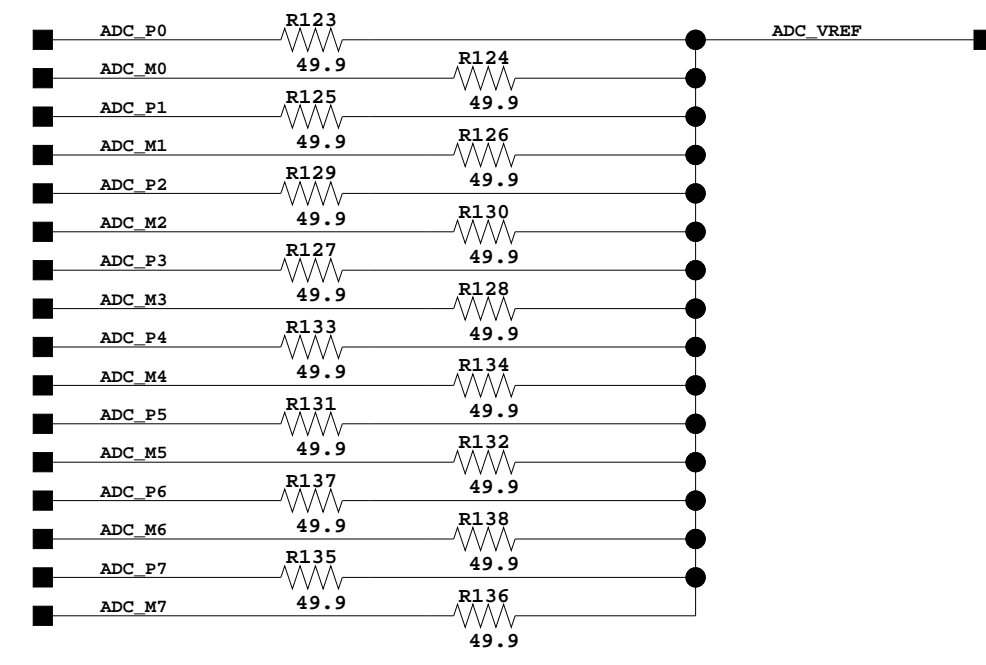

1-24-2011_15:38

SLAC NATIONAL ACCELERATOR LABORATORY U.S. DEPARTMENT OF ENERGY		SHEET 5 OF 23
STANFORD UNIVERSITY STANFORD, CALIFORNIA		HEAVY P TRACKER READOUT RTM 8 CHANNEL ADC
PROPRIETARY DATA OF STANFORD UNIVERSITY AND/OR U.S. DEPARTMENT OF ENERGY. RECIPIENT SHALL NOT PUBLISH THE INFORMATION WITHIN UNLESS GRANTED SPECIFIC PERMISSION OF STANFORD UNIVERSITY.		
INGR Ryan Herbst	DATE 2010	APPROVALS
LOCATED AT SHEET 3		
SD-249-901-02-C01		

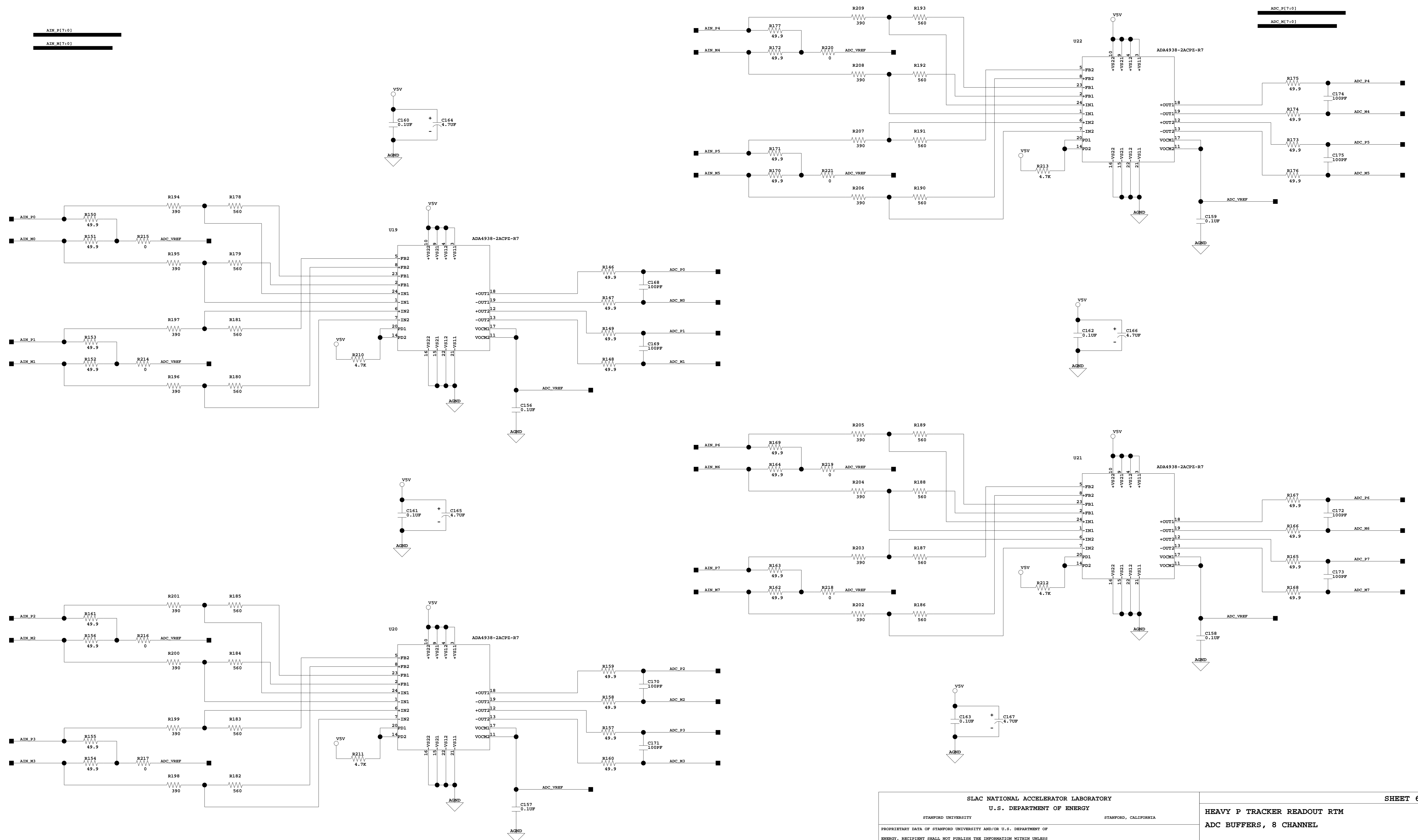

1-24-2011_15:38

SLAC NATIONAL ACCELERATOR LABORATORY U.S. DEPARTMENT OF ENERGY	
STANFORD UNIVERSITY	STANFORD, CALIFORNIA
<small>PROPRIETARY DATA OF STANFORD UNIVERSITY AND/OR U.S. DEPARTMENT OF ENERGY. RECIPIENT SHALL NOT PUBLISH THE INFORMATION WITHIN UNLESS GRANTED SPECIFIC PERMISSION OF STANFORD UNIVERSITY.</small>	
DRGR	DATE
OTFR	APPROVALS
CDR	

SHEET 6 OF 23

HEAVY P TRACKER READOUT RTM
ADC BUFFERS, 8 CHANNEL

LOCATED AT SHEET 3
SD-249-901-02-C01

ADC INPUT TERMINATION
PLACE NEAR ADC

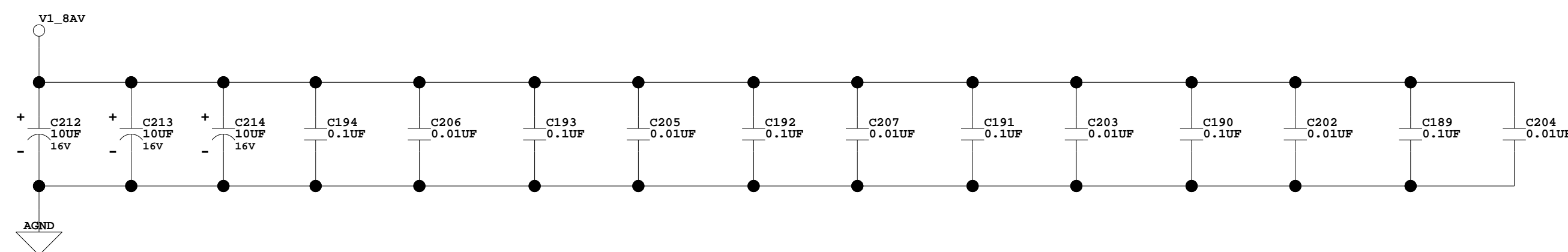
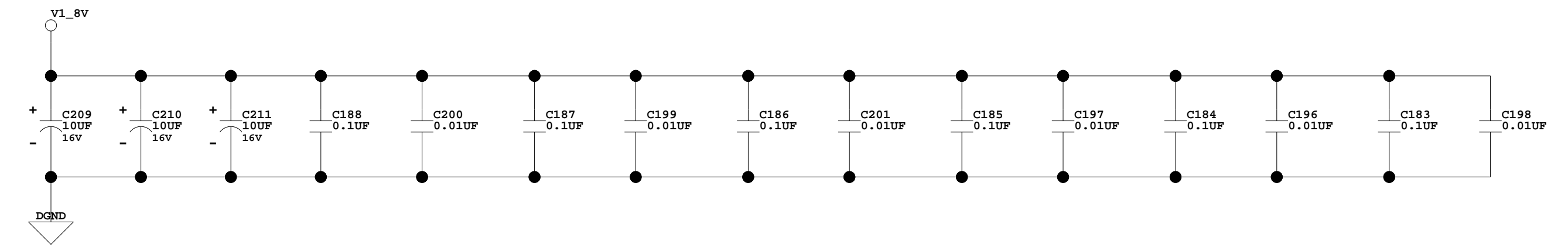
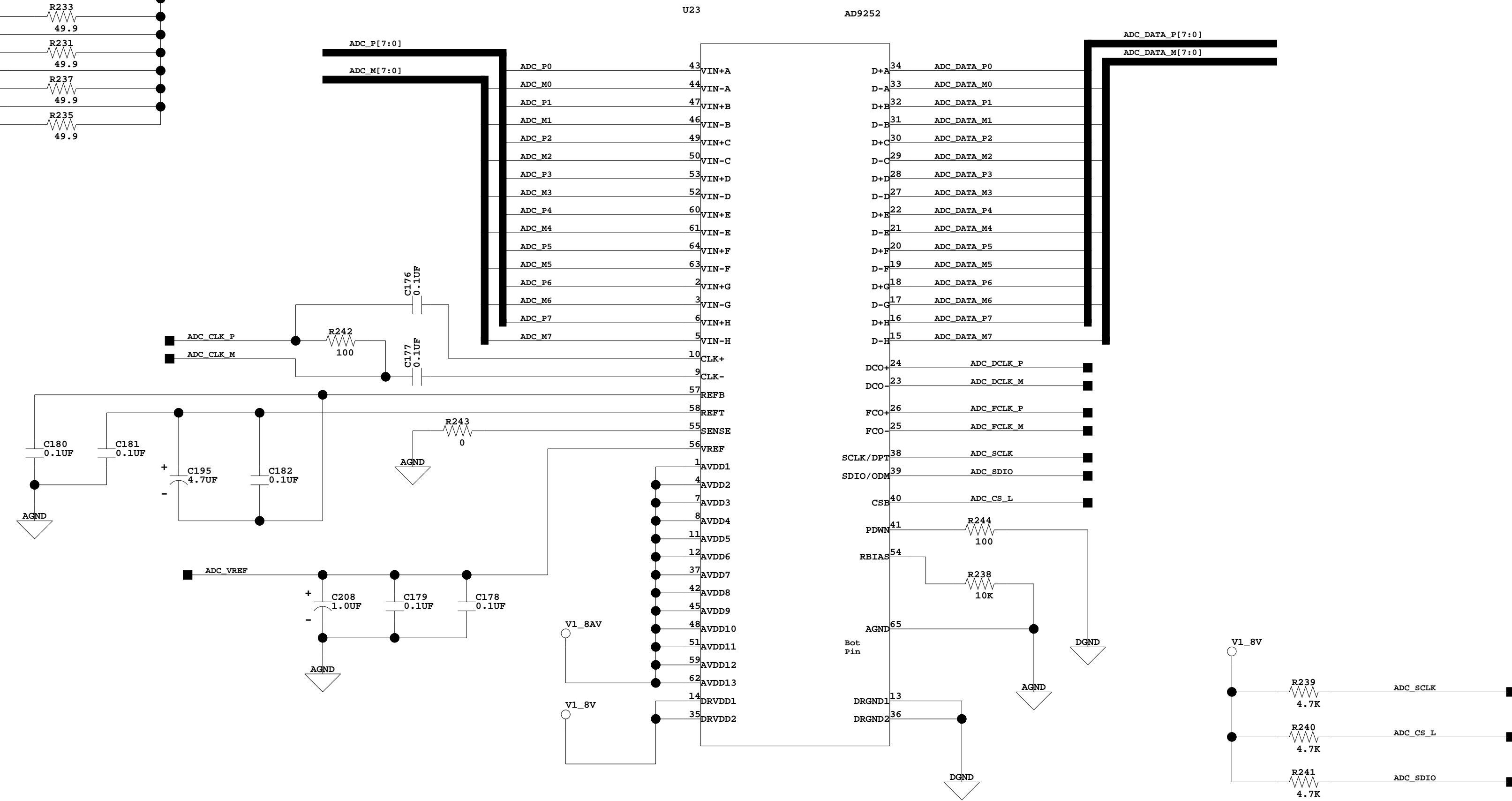
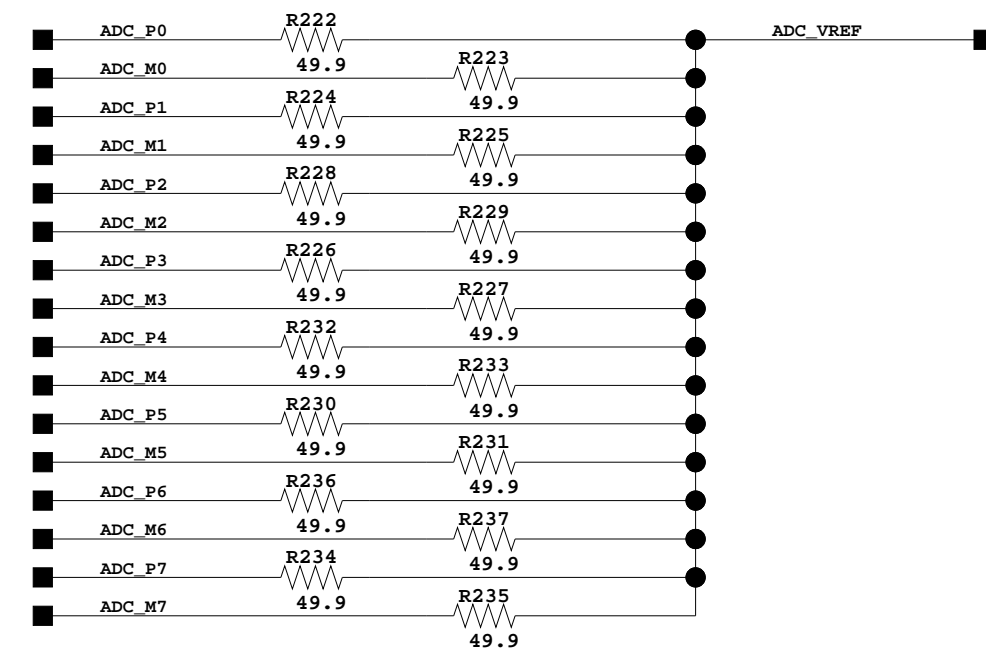

1-24-2011_15:38

SLAC NATIONAL ACCELERATOR LABORATORY U.S. DEPARTMENT OF ENERGY		SHEET 7 OF 23
STANFORD UNIVERSITY STANFORD, CALIFORNIA		HEAVY P TRACKER READOUT RTM 8 CHANNEL ADC
PROPRIETARY DATA OF STANFORD UNIVERSITY AND/OR U.S. DEPARTMENT OF ENERGY. RECIPIENT SHALL NOT PUBLISH THE INFORMATION WITHIN UNLESS GRANTED SPECIFIC PERMISSION OF STANFORD UNIVERSITY.		
INGR	Ryan Herbst	DATE
DPTH		APPROVALS
CMR		LOCATED AT SHEET 3
		SD-249-901-02-C01

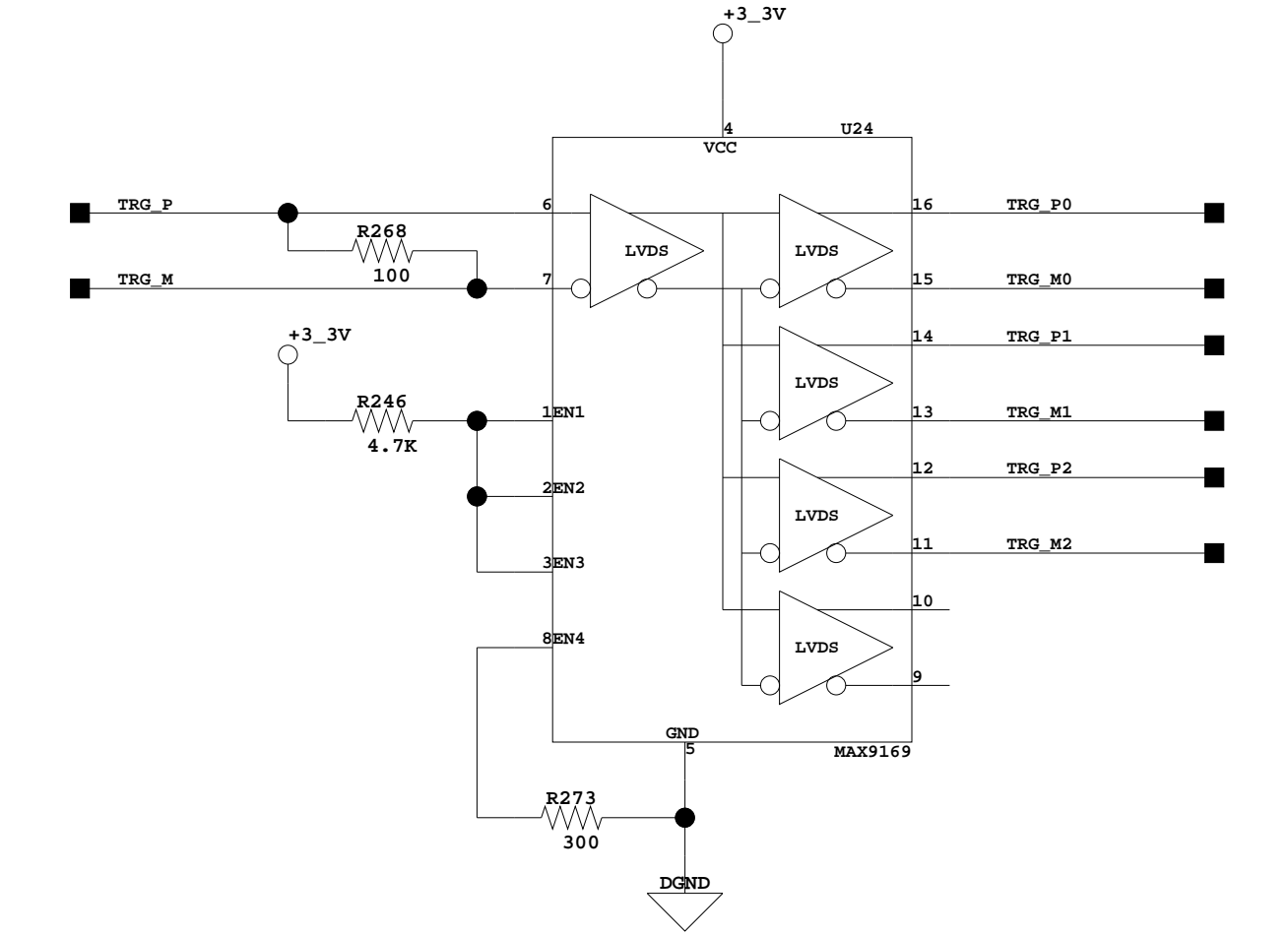
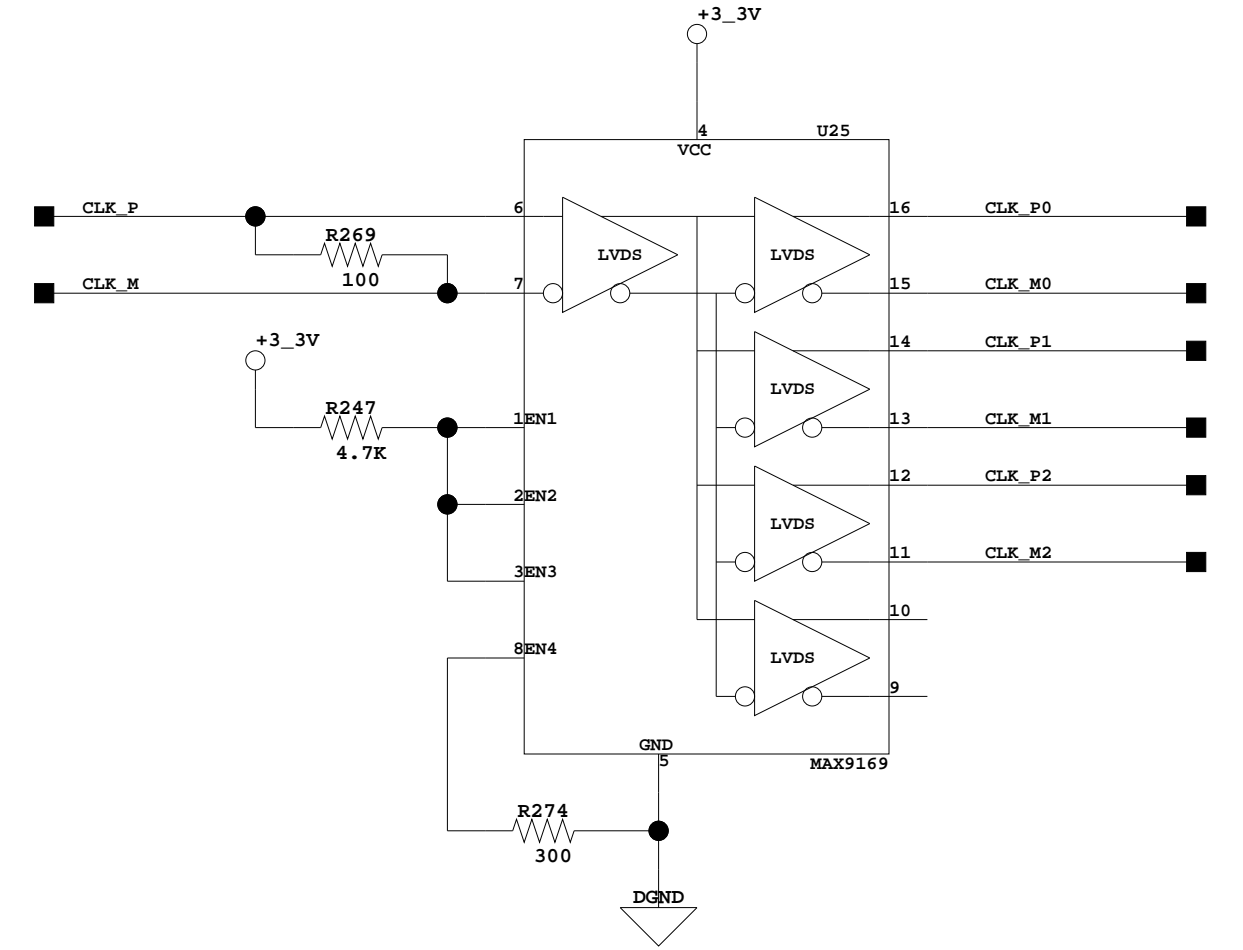
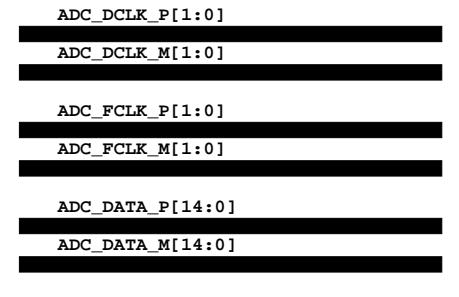
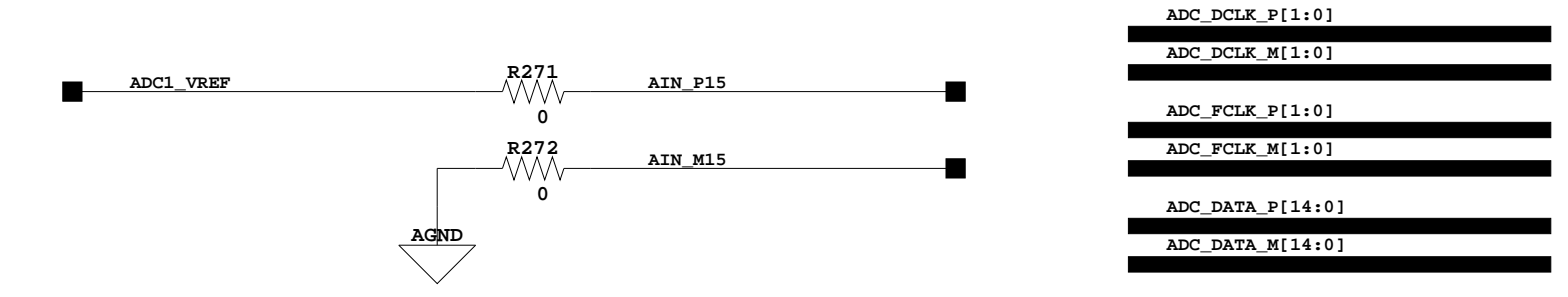
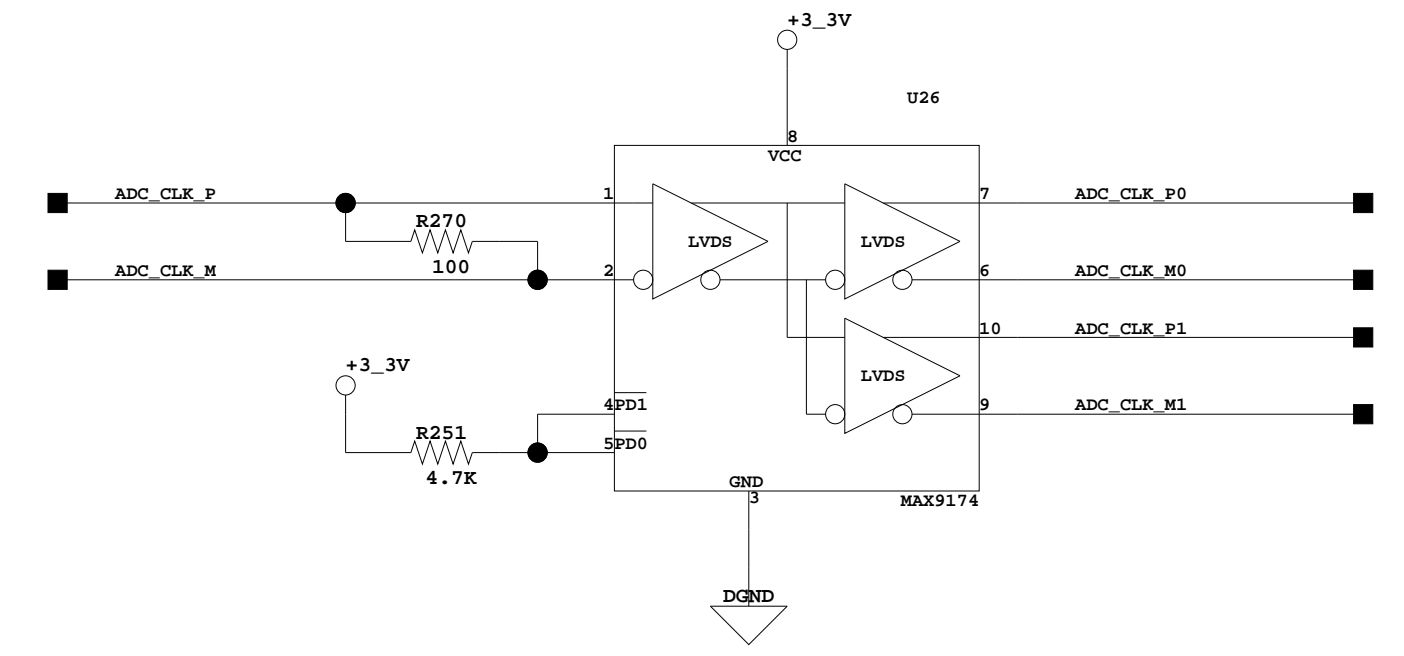
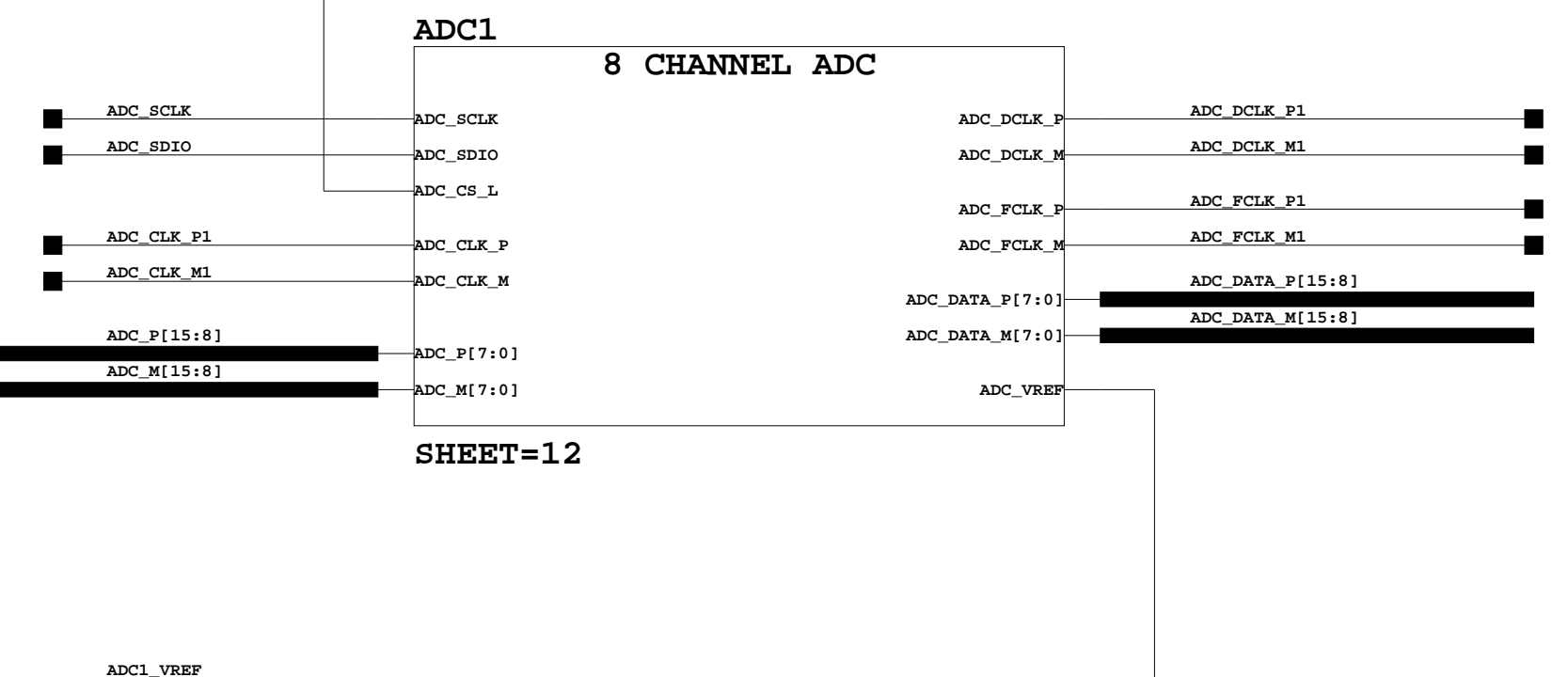
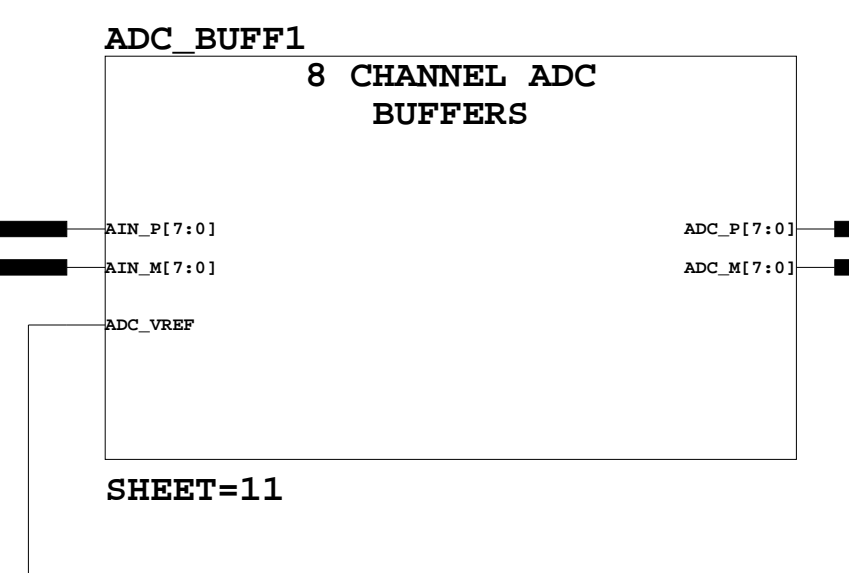
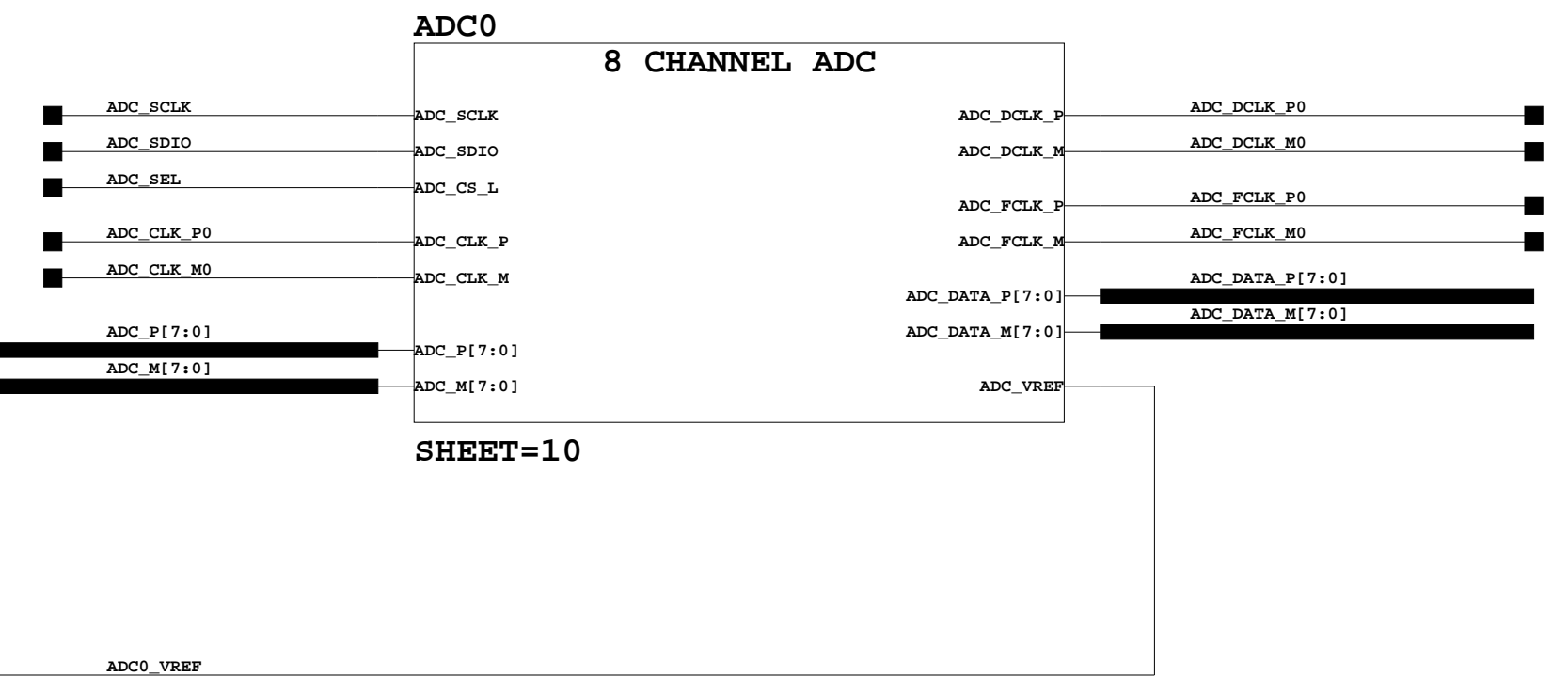
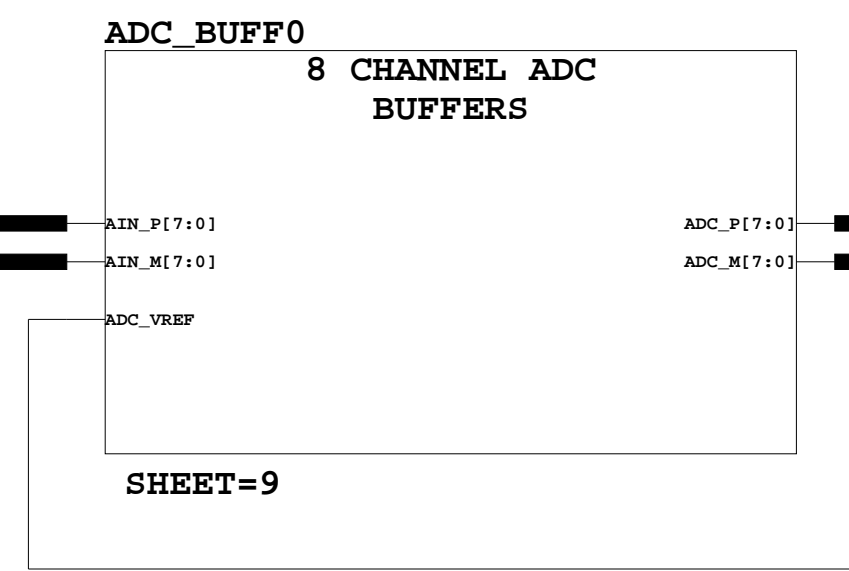
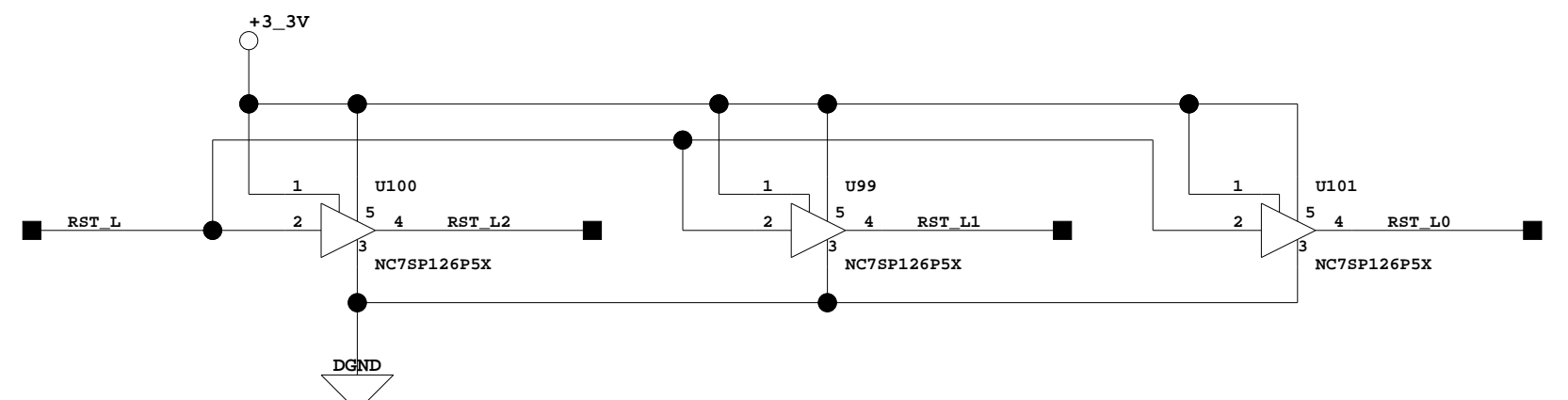
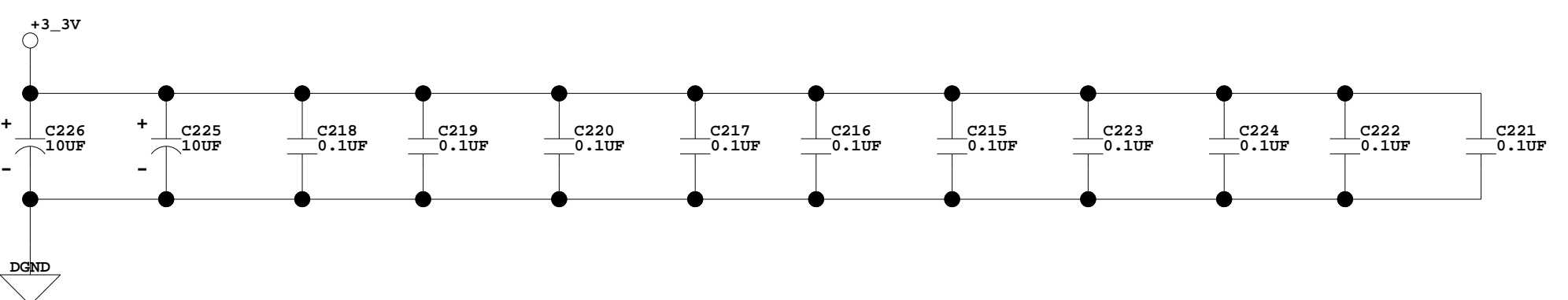
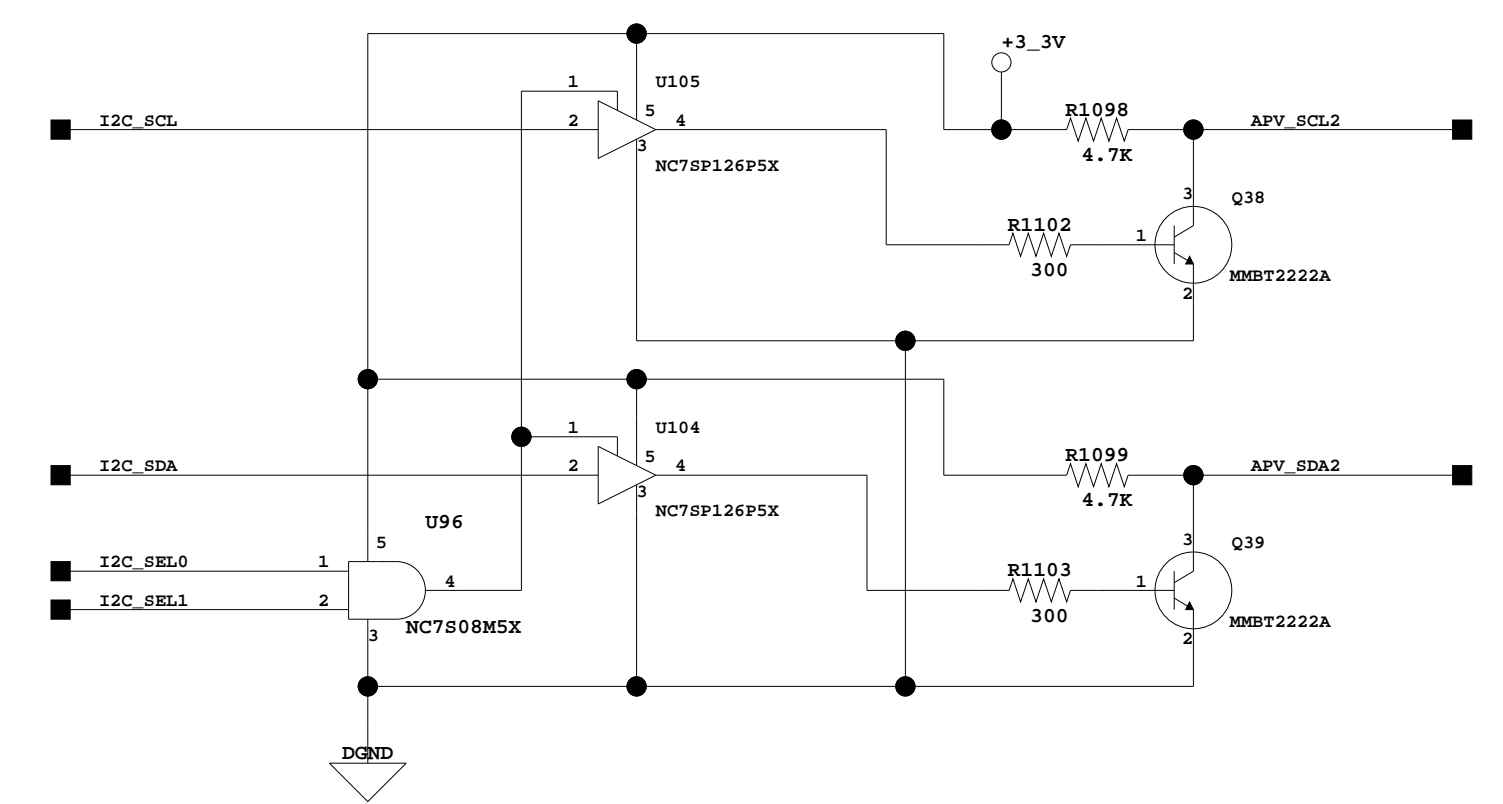
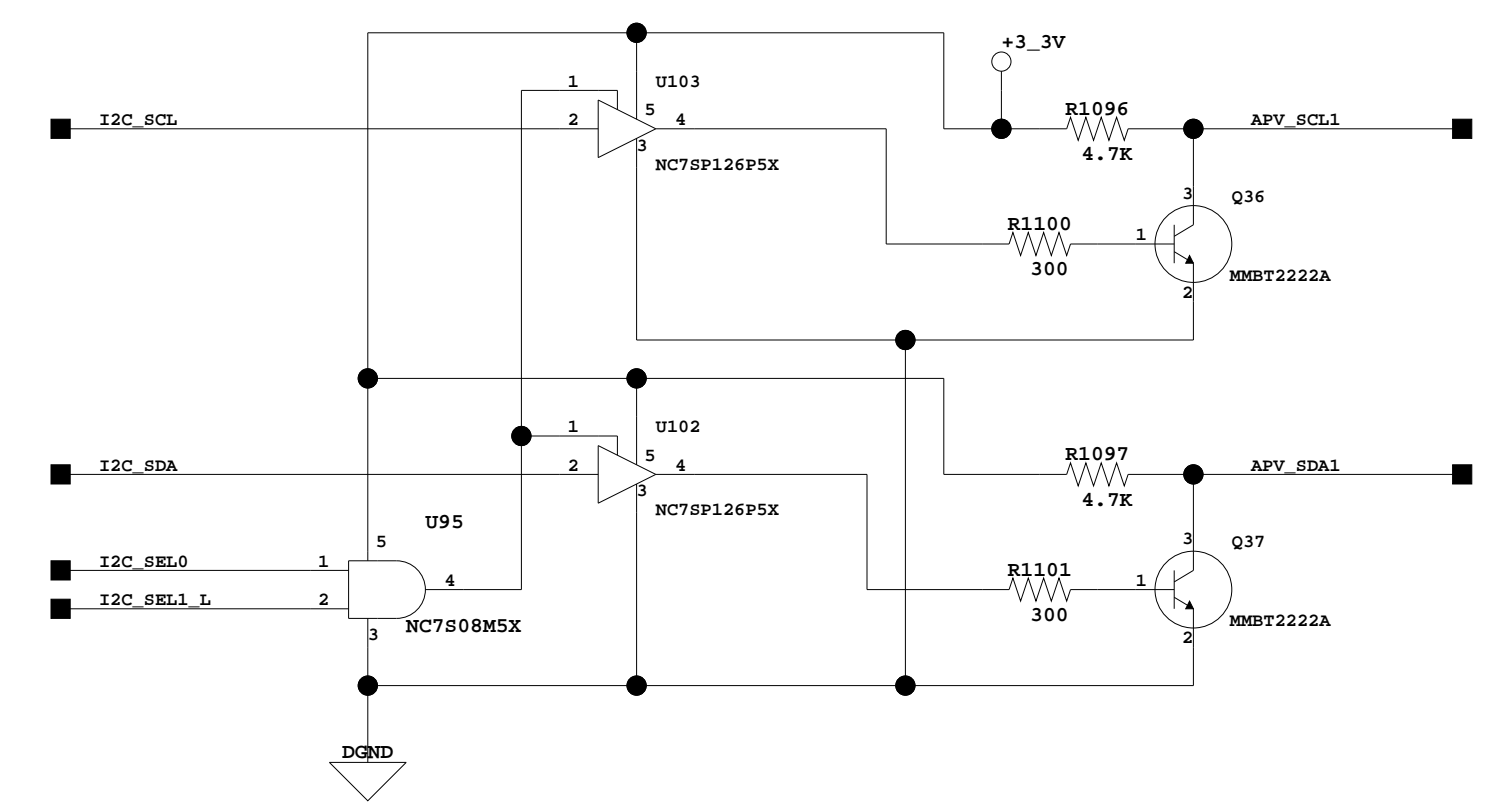
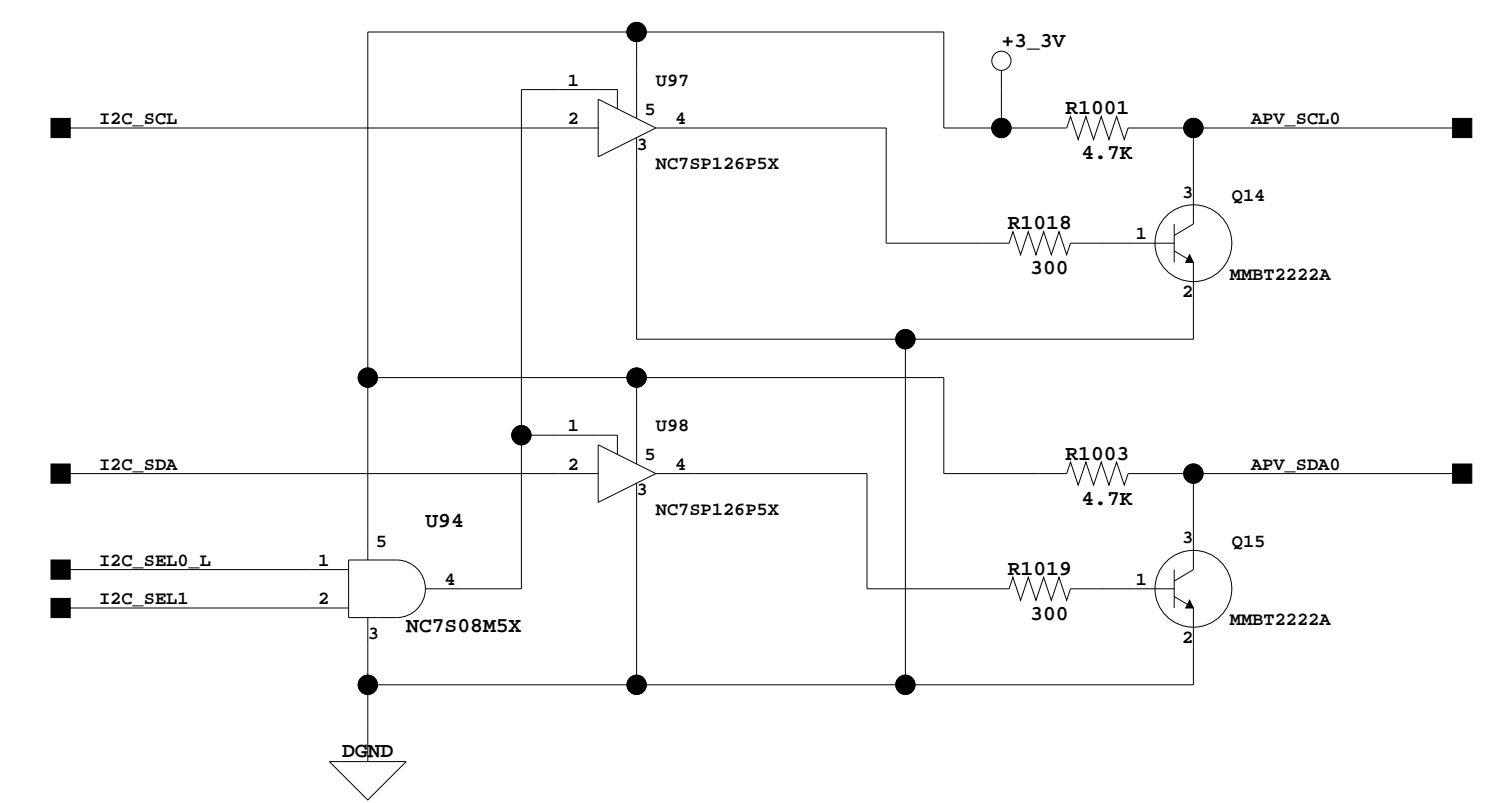
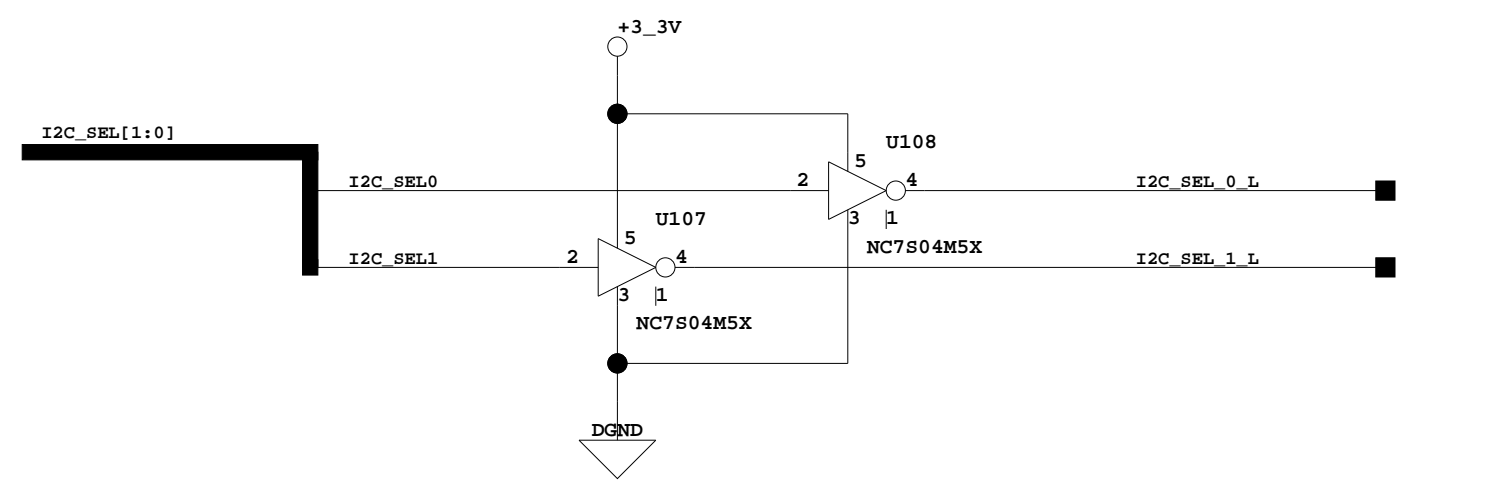
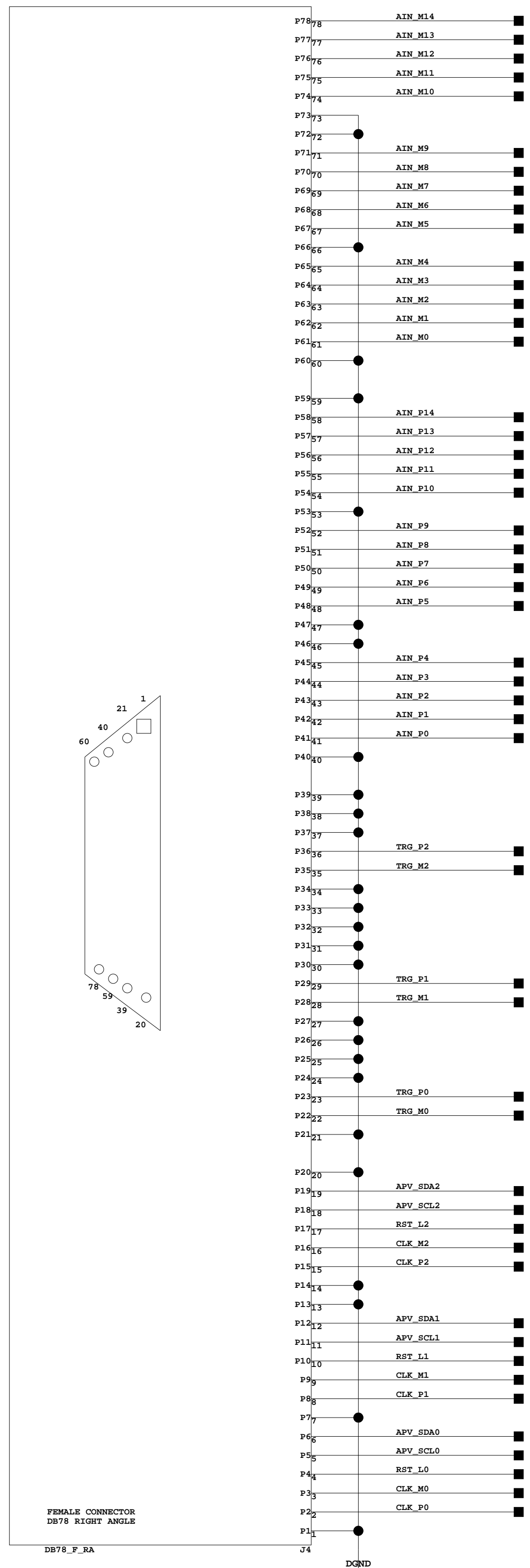

SLAC NATIONAL ACCELERATOR LABORATORY
U.S. DEPARTMENT OF ENERGY

STANFORD UNIVERSITY STANFORD, CALIFORNIA

PROPRIETARY DATA OF STANFORD UNIVERSITY AND/OR U.S. DEPARTMENT OF ENERGY. RECIPIENT SHALL NOT PUBLISH THE INFORMATION WITHIN UNLESS GRANTED SPECIFIC PERMISSION OF STANFORD UNIVERSITY.

DATE	APPROVALS
2010	Ryan Herbst

SHEET 8 OF 23

HEAVY P TRACKER READOUT RTM
APV25 CONNECTOR

LOCATED AT SHEET 1
SD-249-901-02-C01

4-11-2011_15:42

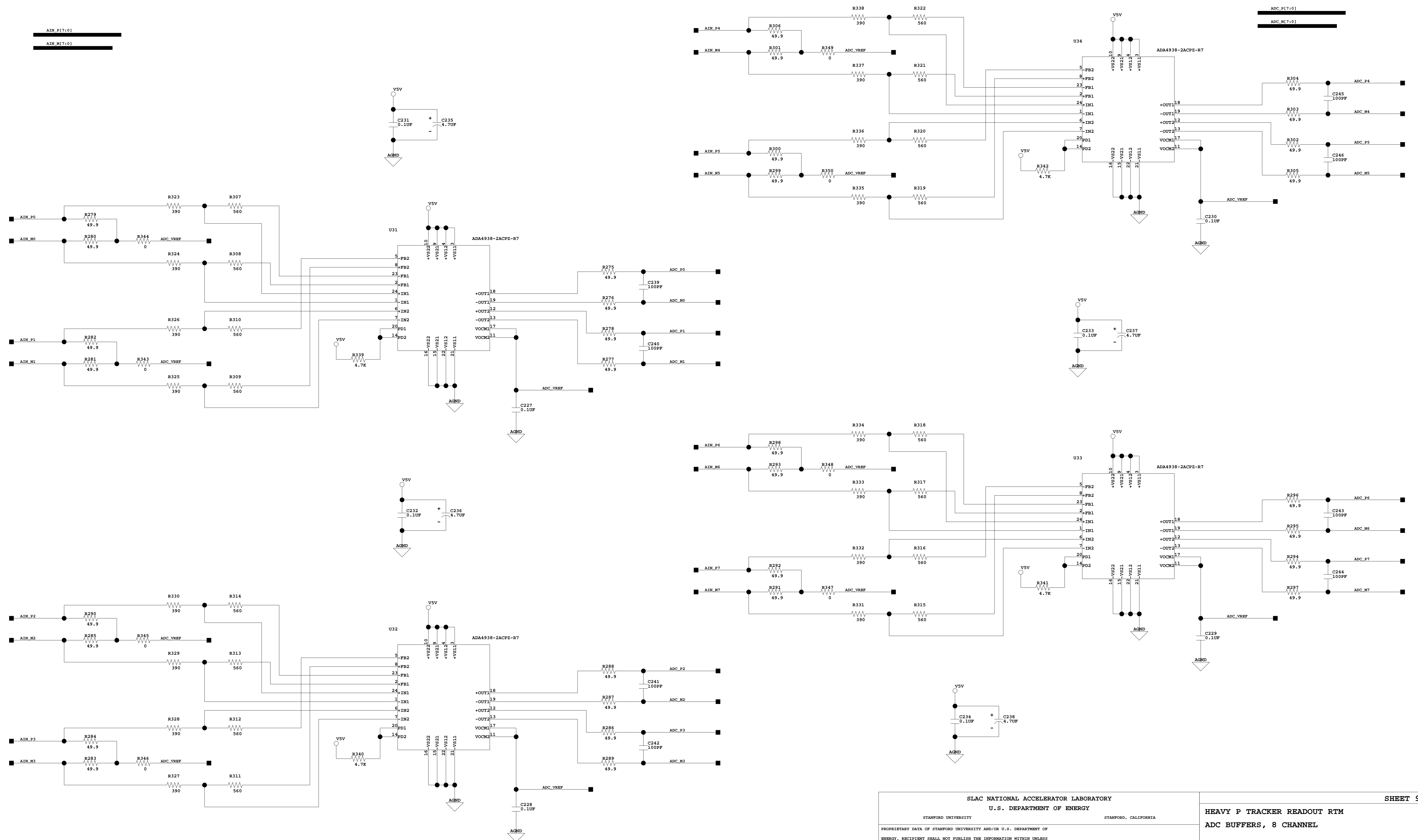

1-24-2011_15:38

SLAC NATIONAL ACCELERATOR LABORATORY U.S. DEPARTMENT OF ENERGY	
STANFORD UNIVERSITY	STANFORD, CALIFORNIA
PROPRIETARY DATA OF STANFORD UNIVERSITY AND/OR U.S. DEPARTMENT OF ENERGY. RECIPIENT SHALL NOT PUBLISH THE INFORMATION WITHIN UNLESS GRANTED SPECIFIC PERMISSION OF STANFORD UNIVERSITY.	
INCR	DATE
DFR	APPROVALS
CDR	

SHEET 9 OF 23

HEAVY P TRACKER READOUT RTM
ADC BUFFERS, 8 CHANNEL

LOCATED AT SHEET 8
 SD-249-901-02-C01

**ADC INPUT TERMINATION
PLACE NEAR ADC**

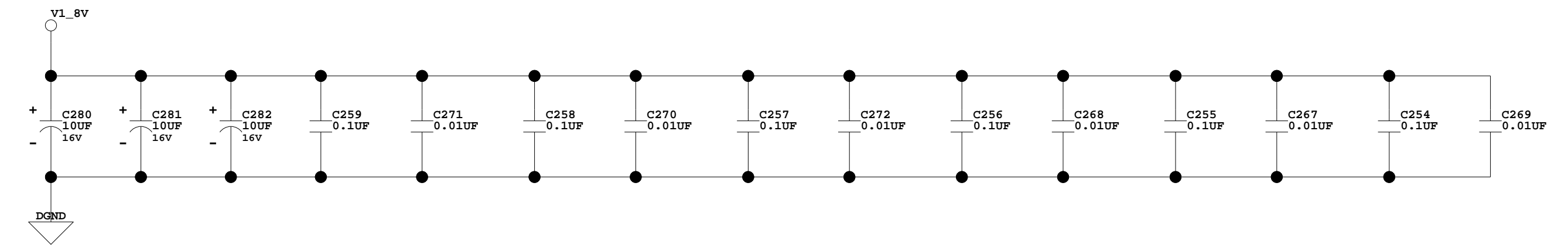
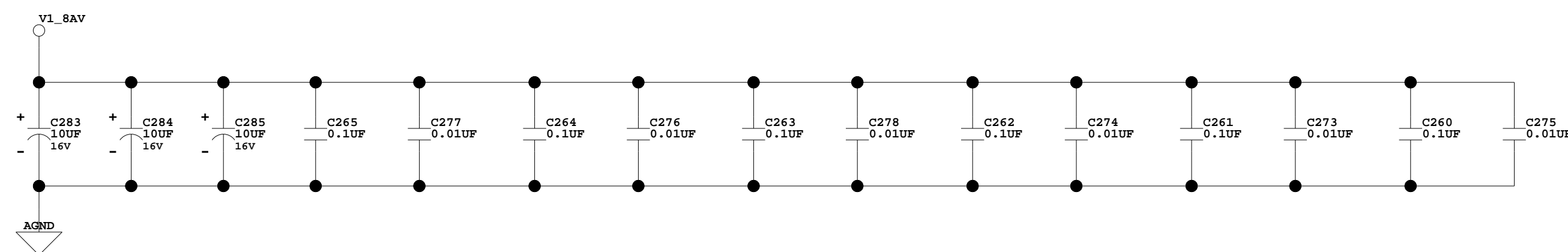
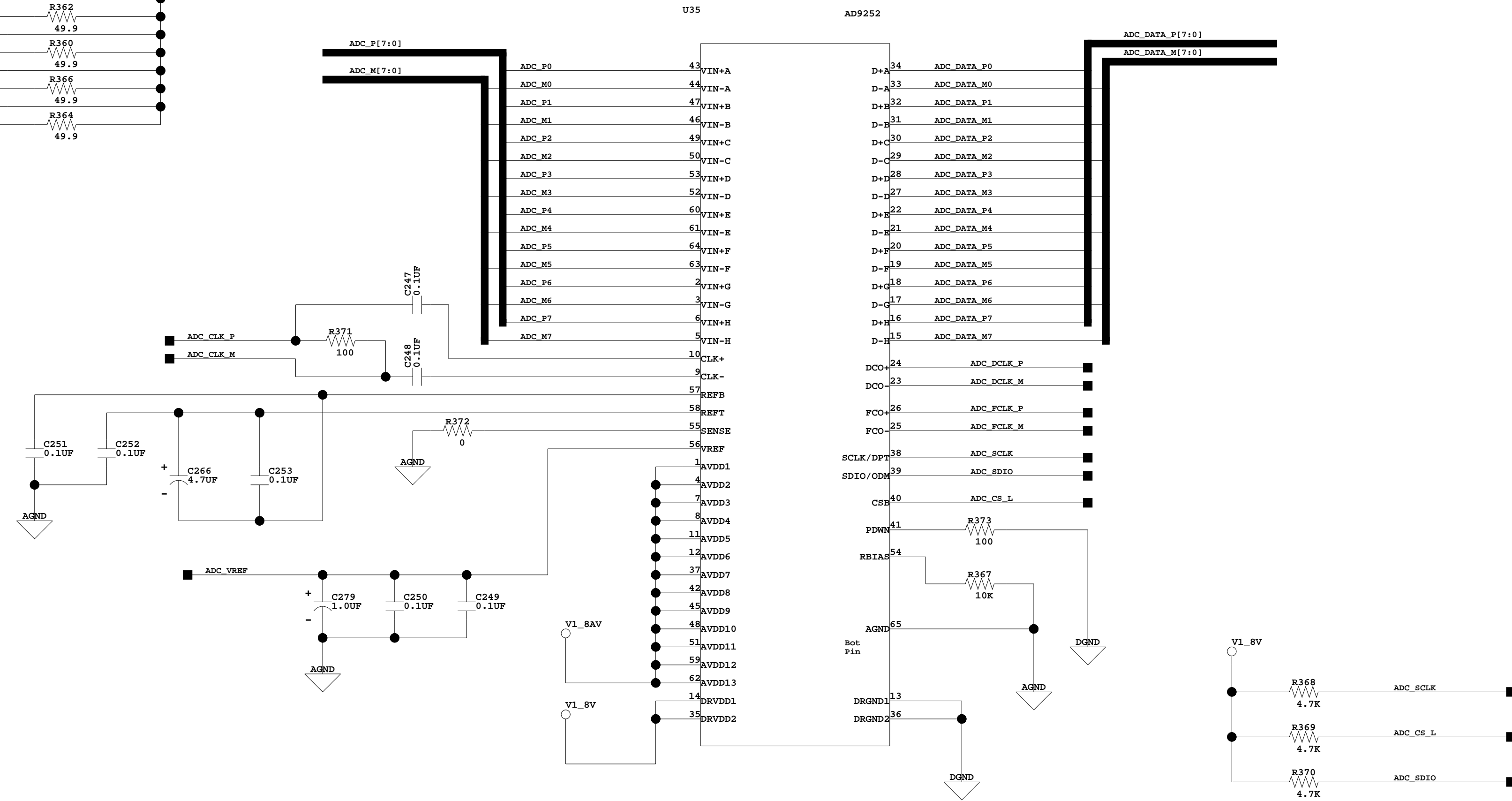
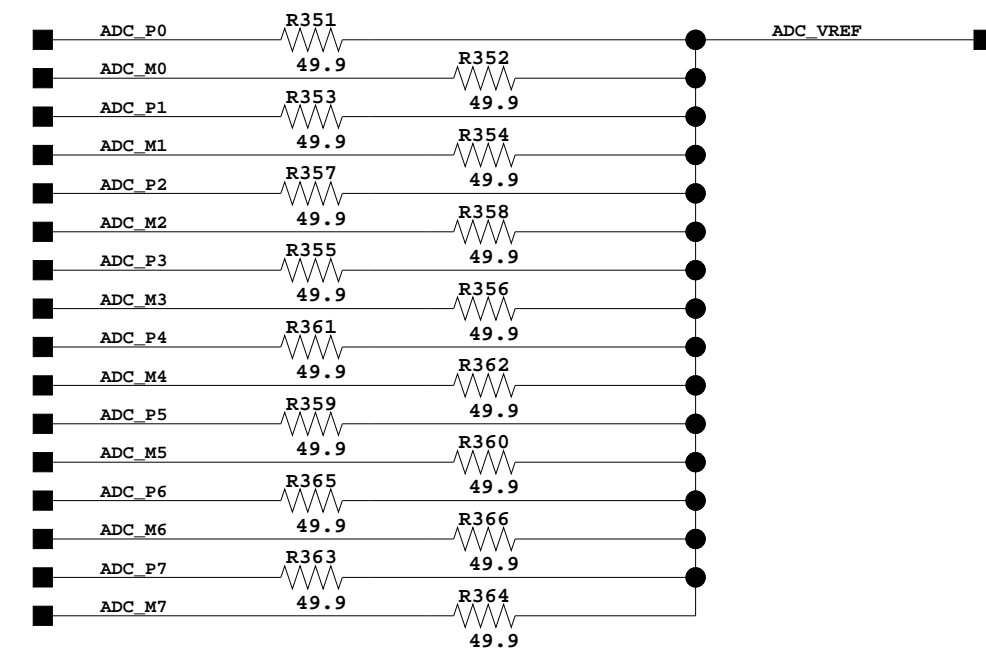

1-24-2011_15:38

SLAC NATIONAL ACCELERATOR LABORATORY U.S. DEPARTMENT OF ENERGY		SHEET 10 OF 23
STANFORD UNIVERSITY STANFORD, CALIFORNIA		HEAVY P TRACKER READOUT RTM 8 CHANNEL ADC
PROPRIETARY DATA OF STANFORD UNIVERSITY AND/OR U.S. DEPARTMENT OF ENERGY. RECIPIENT SHALL NOT PUBLISH THE INFORMATION WITHIN UNLESS GRANTED SPECIFIC PERMISSION OF STANFORD UNIVERSITY.		
INGR	Ryan Herbat	DATE
DPTH		2010
CDRS		APPROVALS
		LOCATED AT SHEET 8
		SD-249-901-02-C01

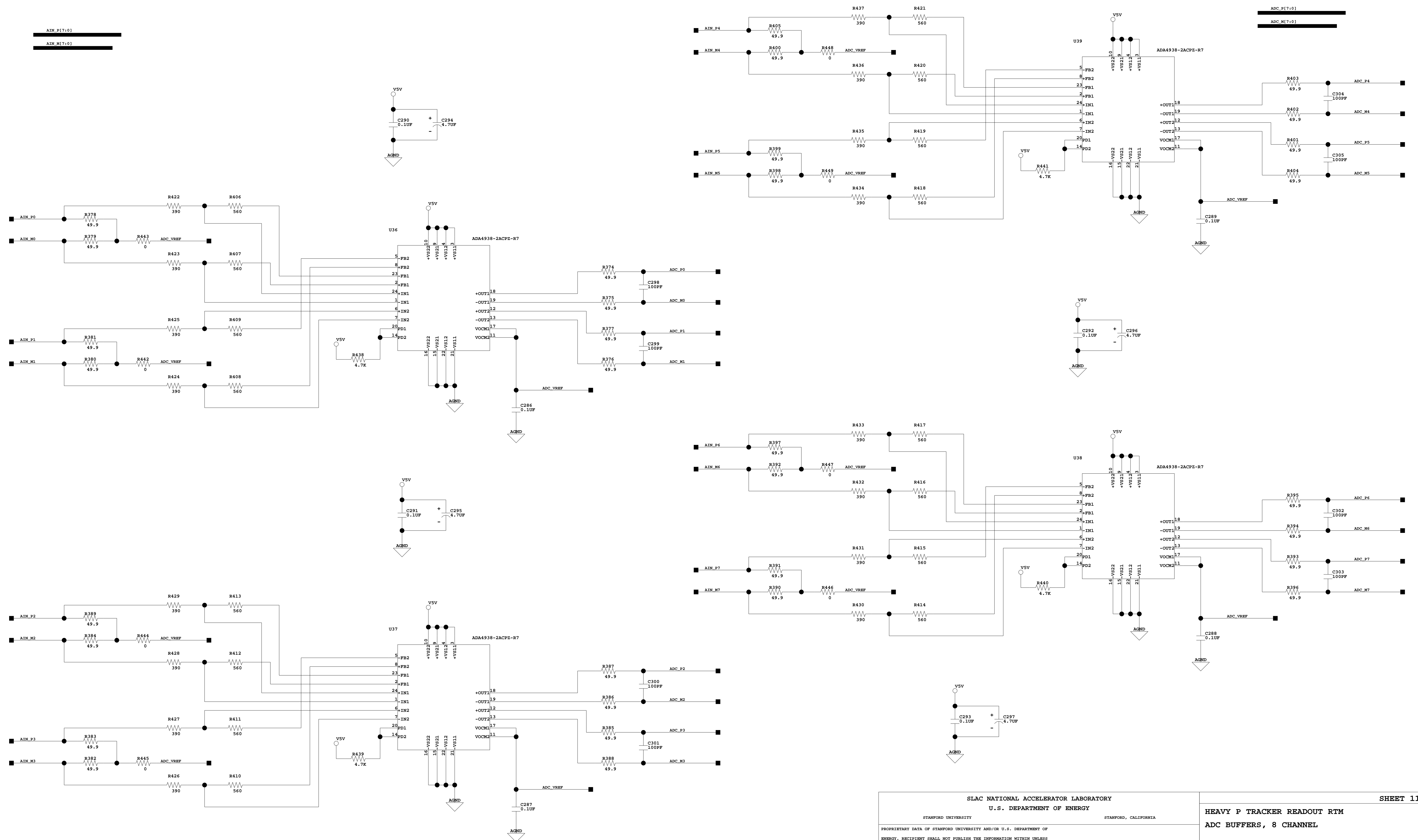

1-24-2011_15:38

SLAC NATIONAL ACCELERATOR LABORATORY U.S. DEPARTMENT OF ENERGY		SHEET 11 OF 23
<small>STANFORD UNIVERSITY</small> <small>STANFORD, CALIFORNIA</small>		HEAVY P TRACKER READOUT RTM ADC BUFFERS, 8 CHANNEL
<small>PROPRIETARY DATA OF STANFORD UNIVERSITY AND/OR U.S. DEPARTMENT OF ENERGY. RECIPIENT SHALL NOT PUBLISH THE INFORMATION WITHIN UNLESS GRANTED SPECIFIC PERMISSION OF STANFORD UNIVERSITY.</small>		
<small>INCR</small>	<small>DATE</small>	<small>APPROVALS</small>
<small>DRFR</small> Ryan Herbst	2010	
<small>CDR</small>		
LOCATED AT SHEET 8		
SD-249-901-02-C01		

**ADC INPUT TERMINATION
PLACE NEAR ADC**

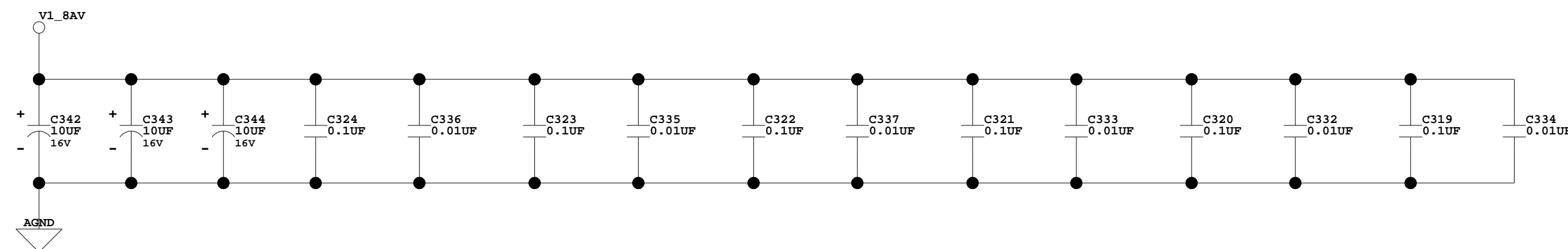
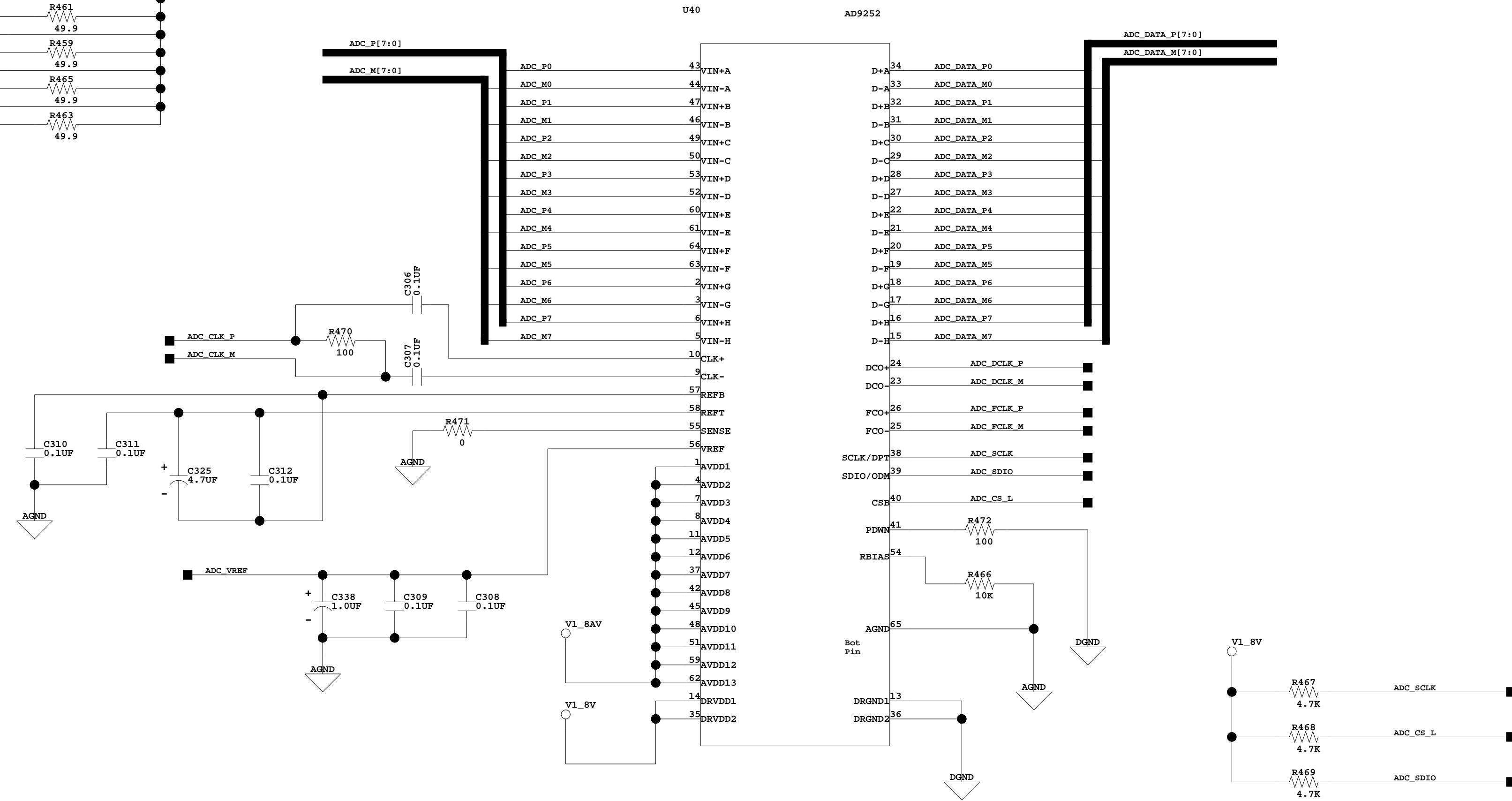
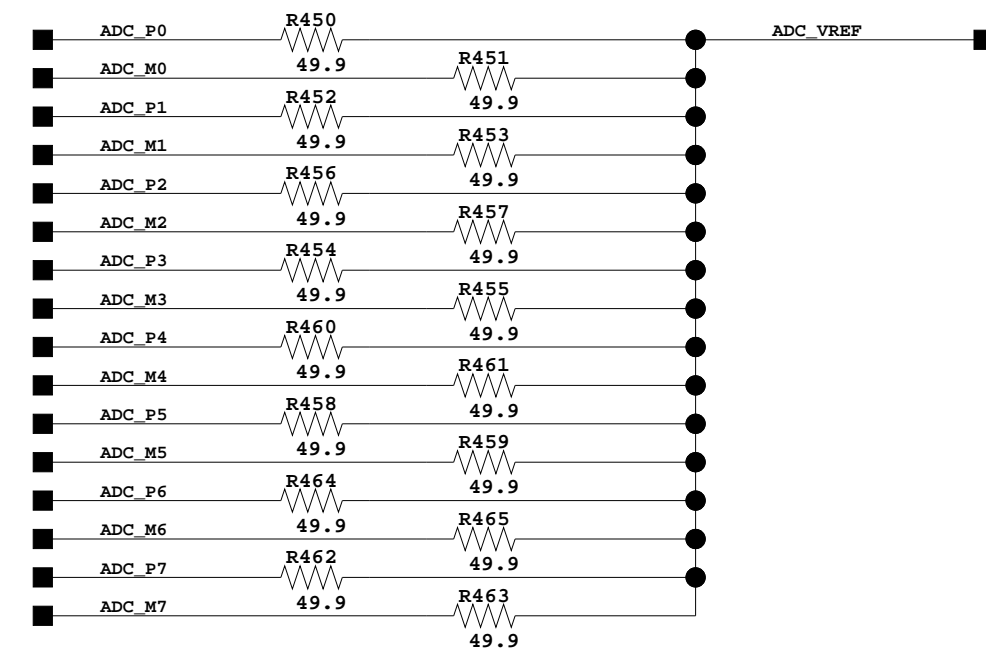

1-24-2011_15:38

SLAC NATIONAL ACCELERATOR LABORATORY U.S. DEPARTMENT OF ENERGY		SHEET 12 OF 23
STANFORD UNIVERSITY STANFORD, CALIFORNIA		HEAVY P TRACKER READOUT RTM 8 CHANNEL ADC
PROPRIETARY DATA OF STANFORD UNIVERSITY AND/OR U.S. DEPARTMENT OF ENERGY. RECIPIENT SHALL NOT PUBLISH THE INFORMATION WITHIN UNLESS GRANTED SPECIFIC PERMISSION OF STANFORD UNIVERSITY.		
INGR Ryan Herbst	DATE 2010	APPROVALS
LOCATED AT SHEET 8 SD-249-901-02-C01		

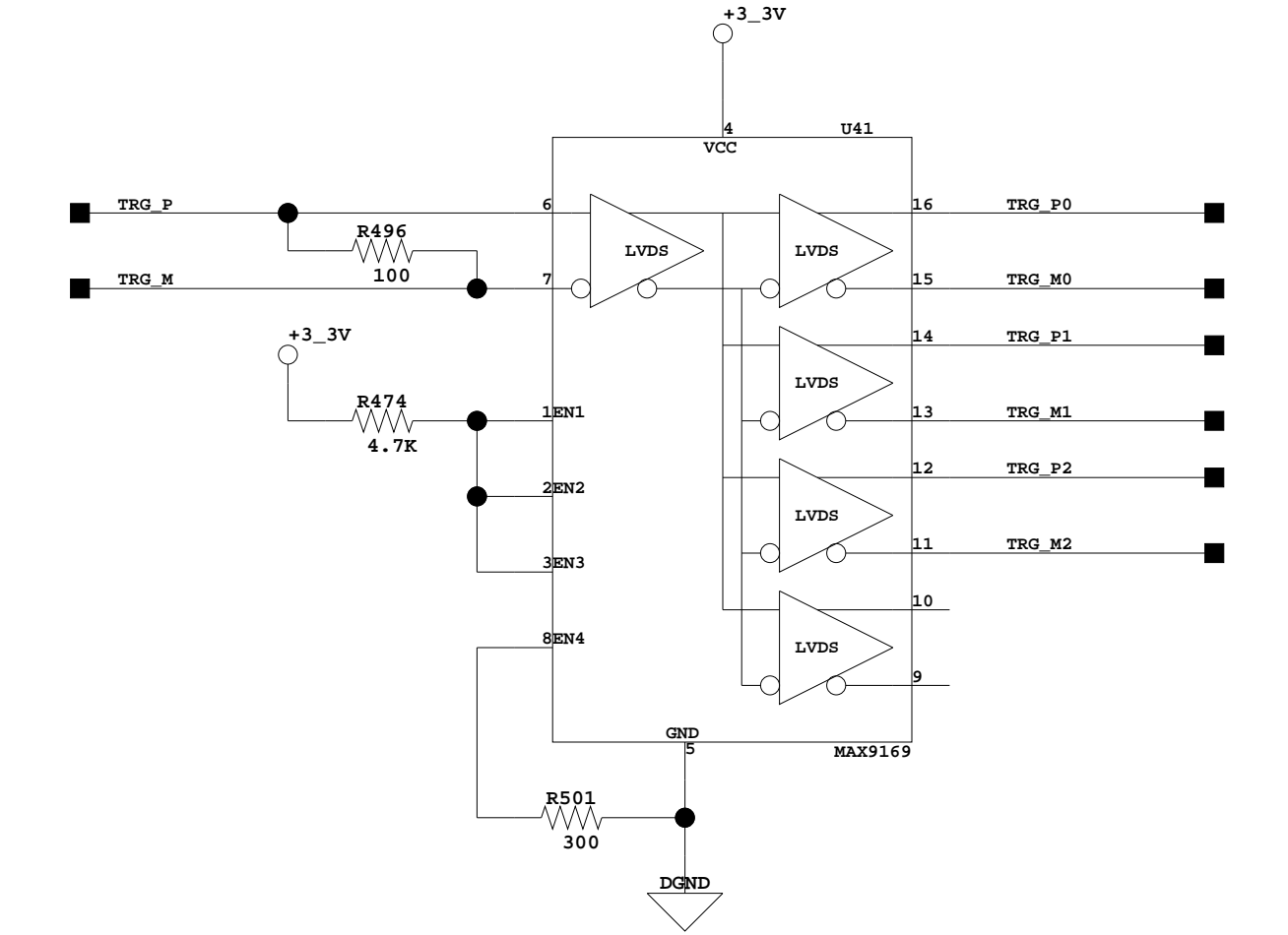
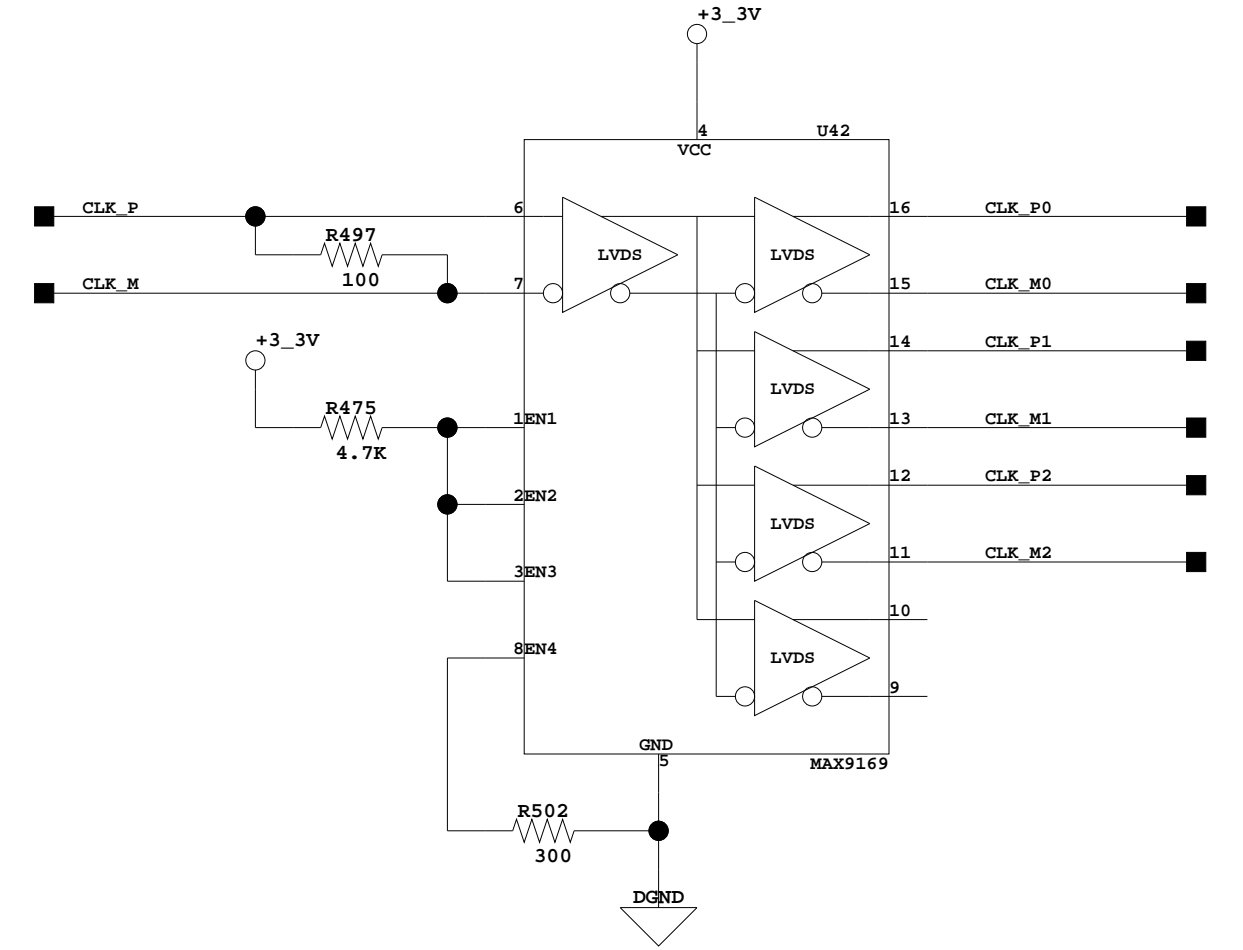
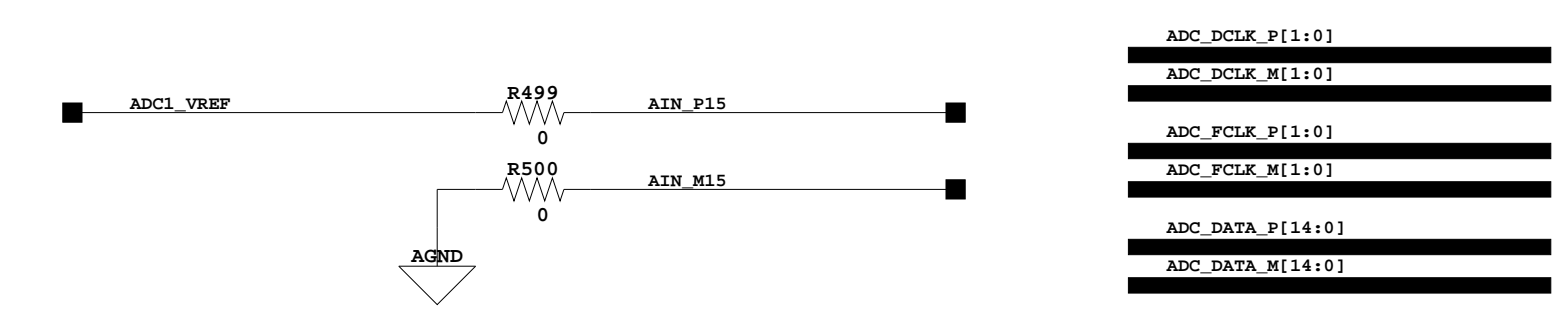
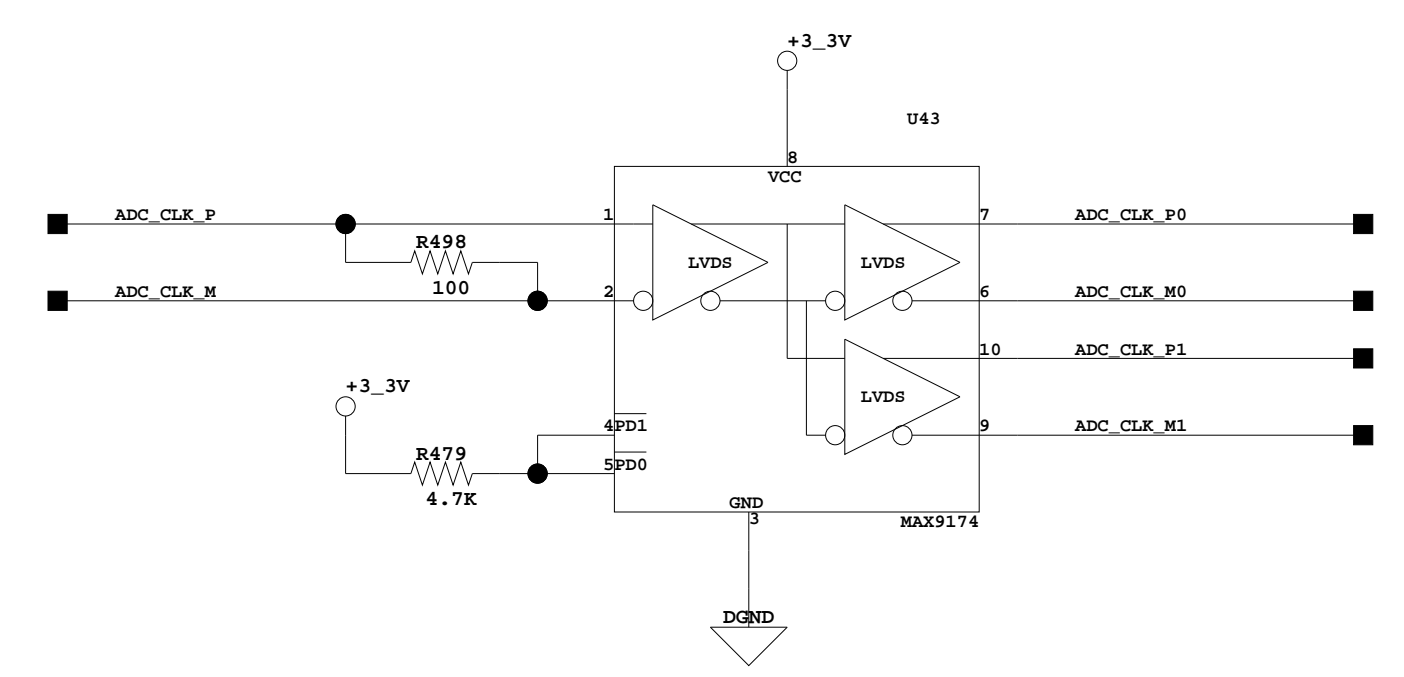
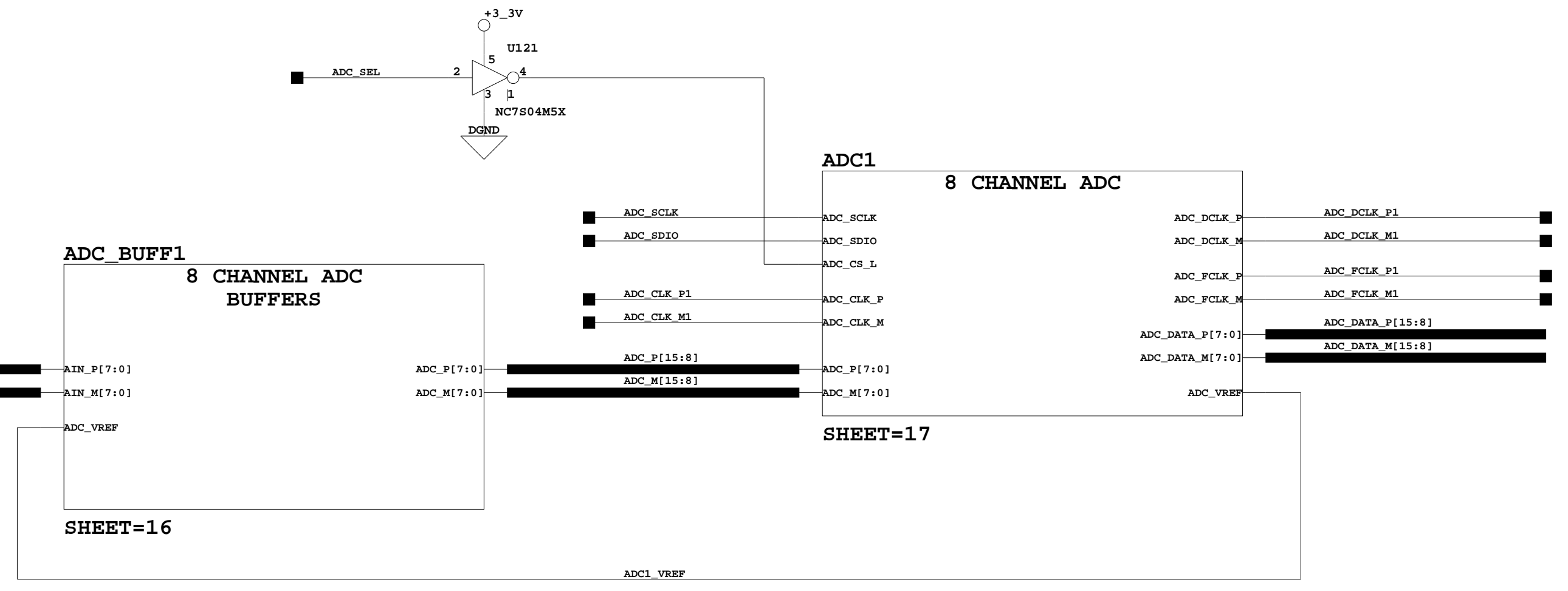
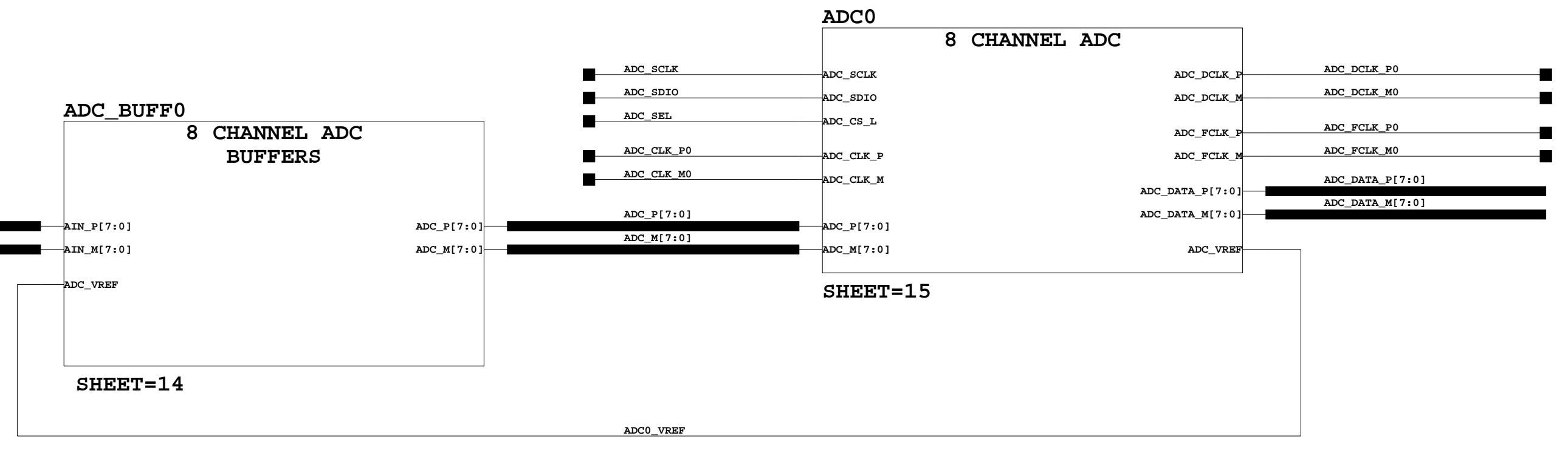
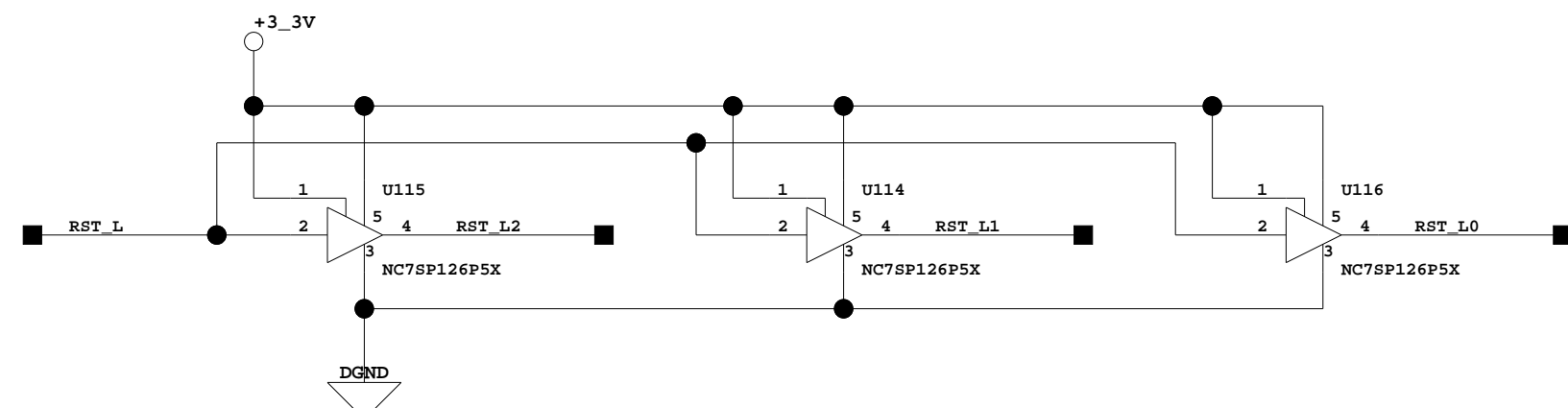
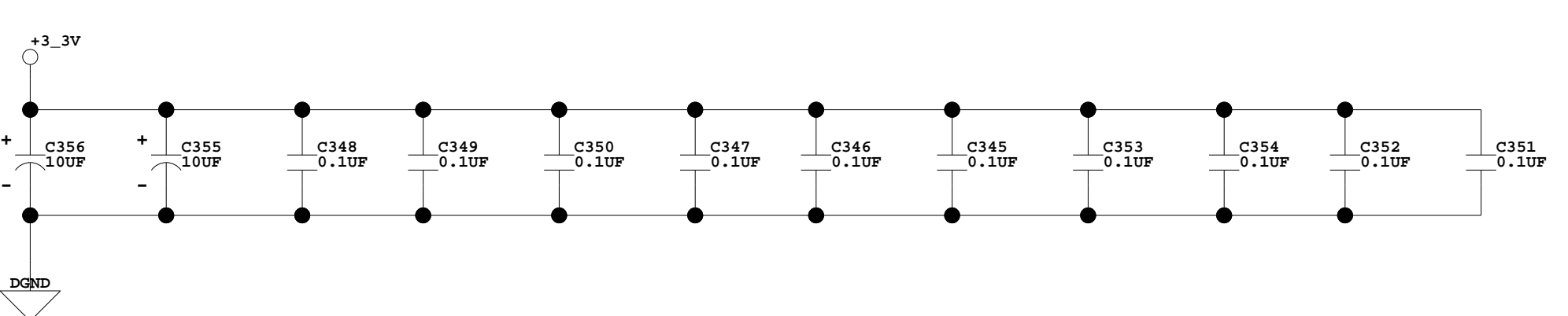
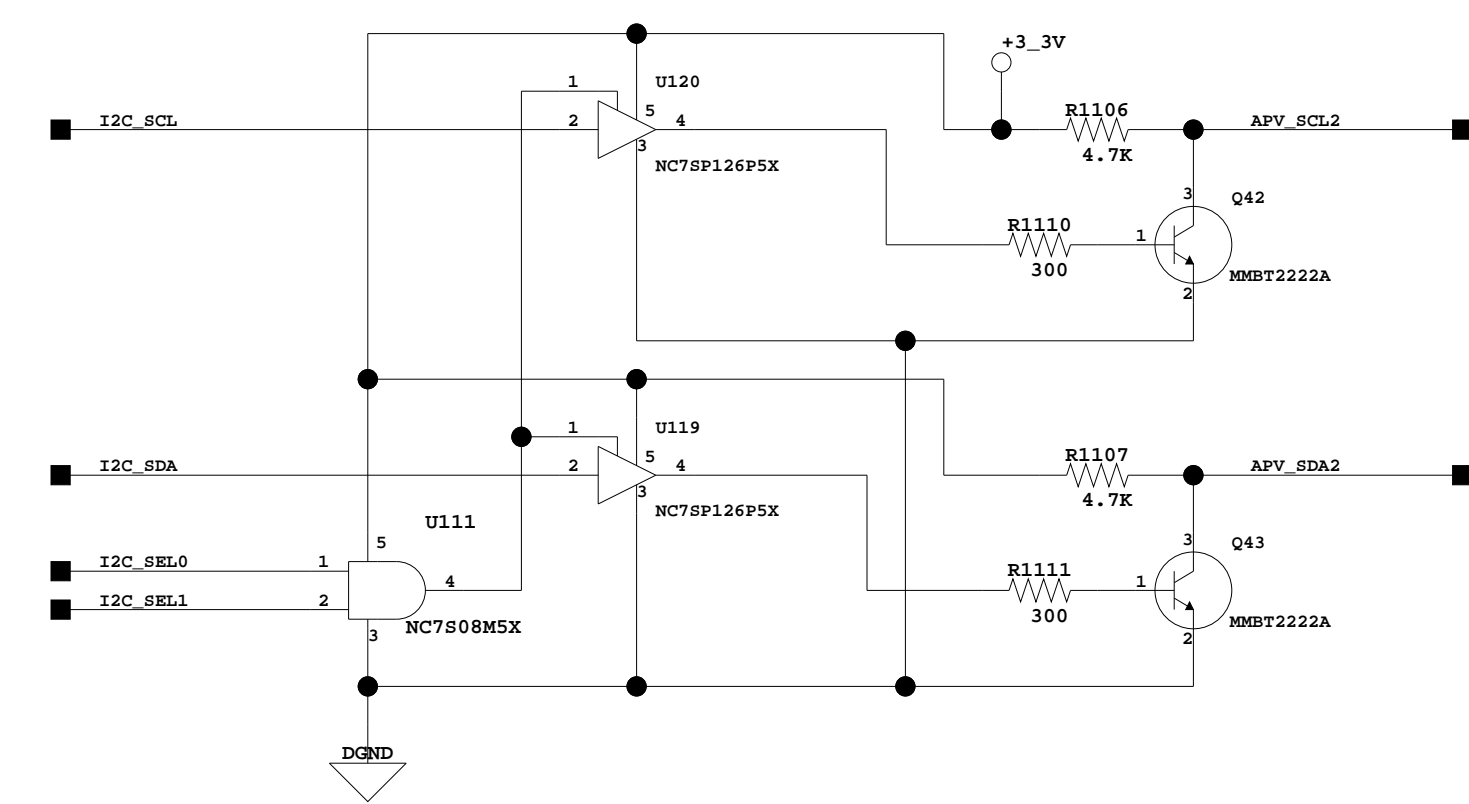
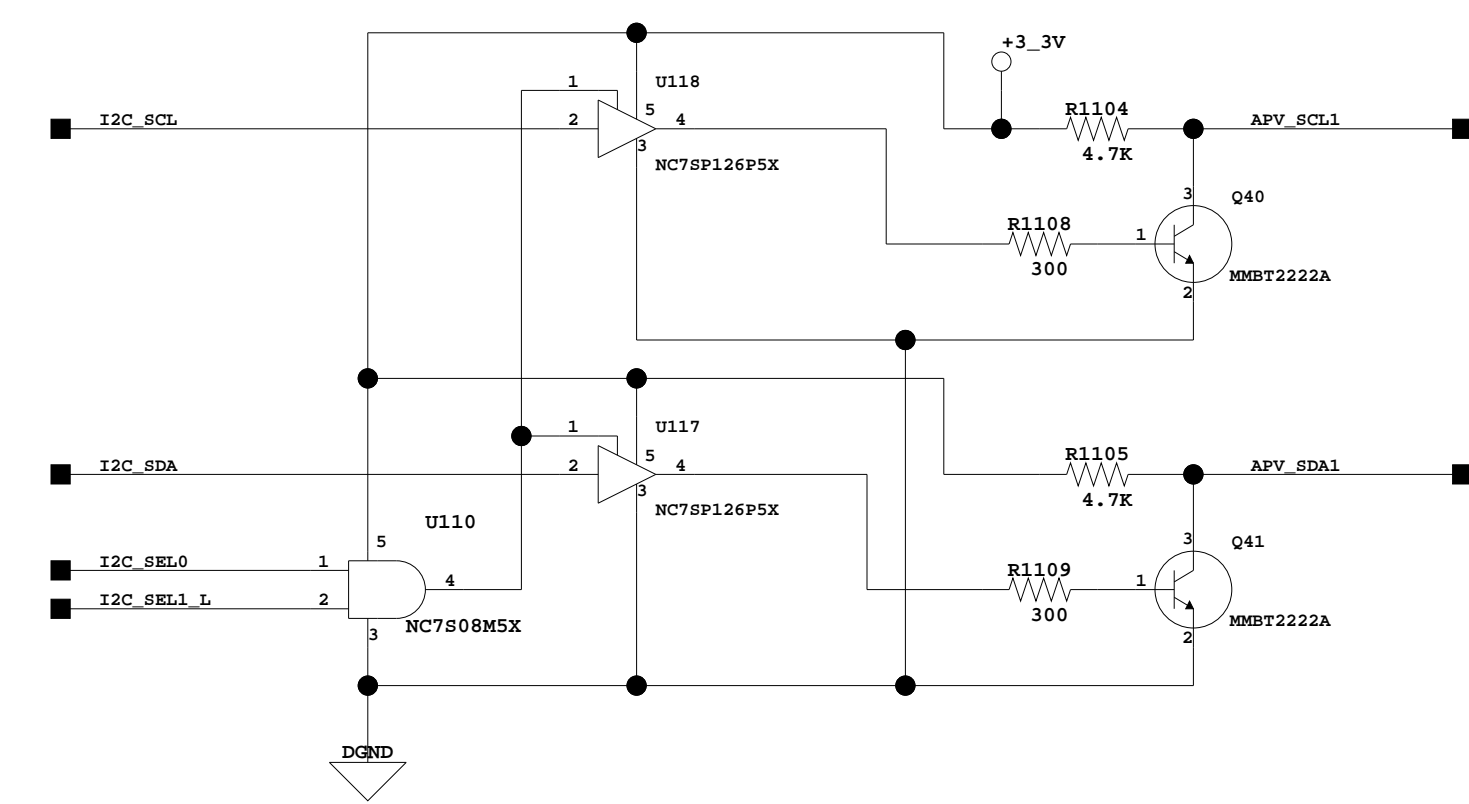
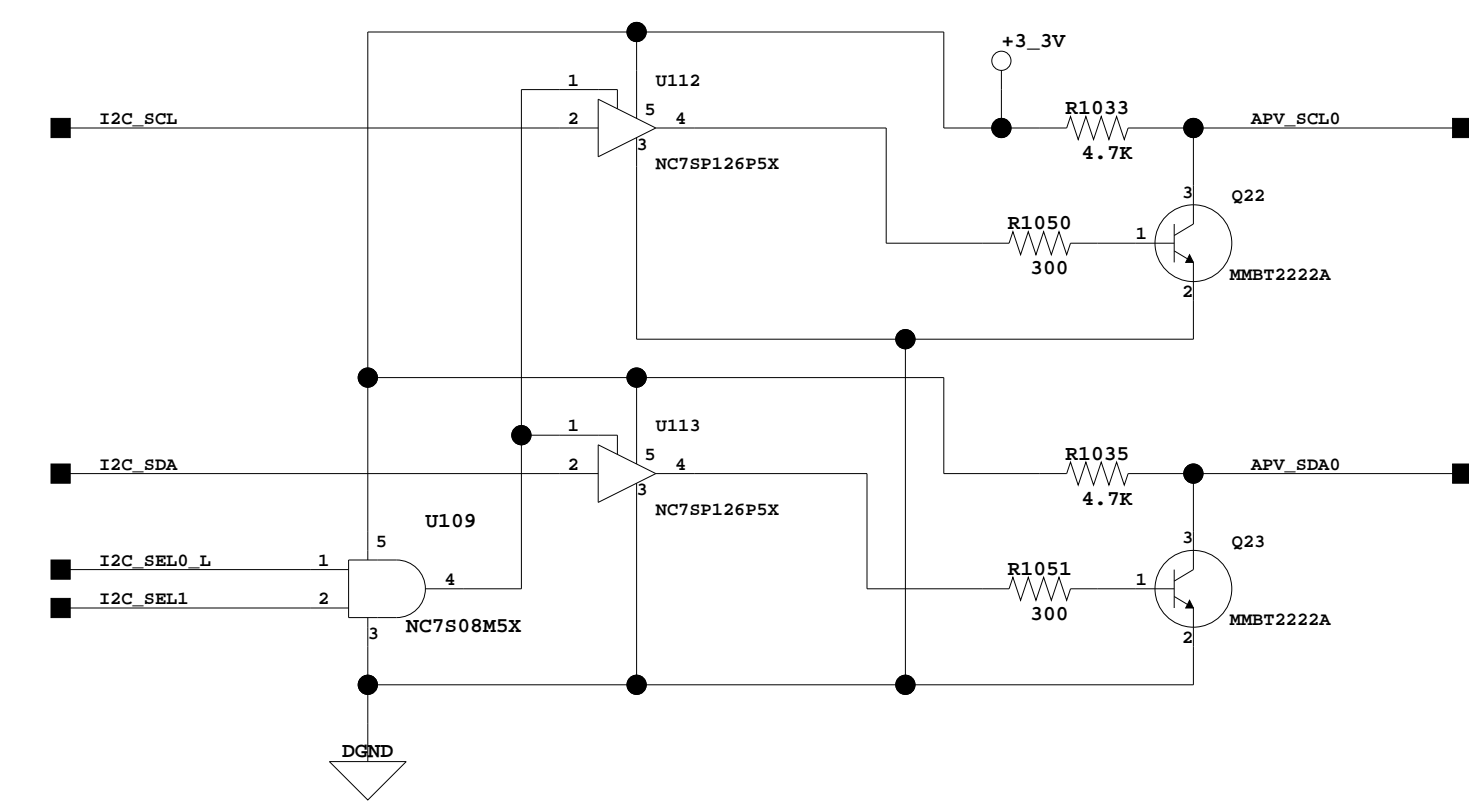
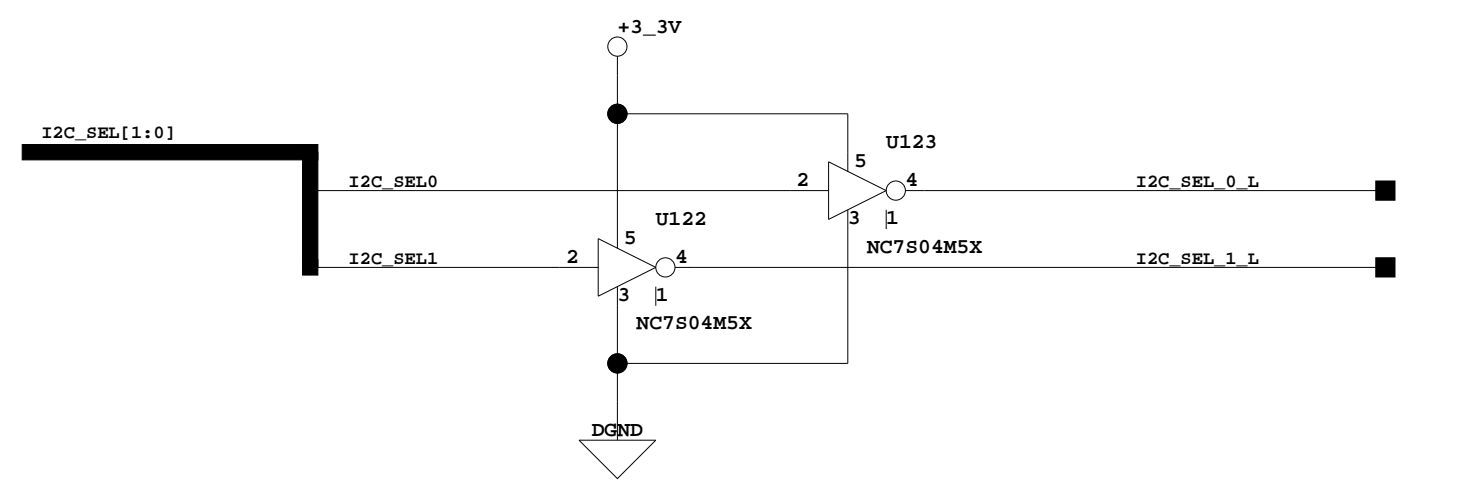
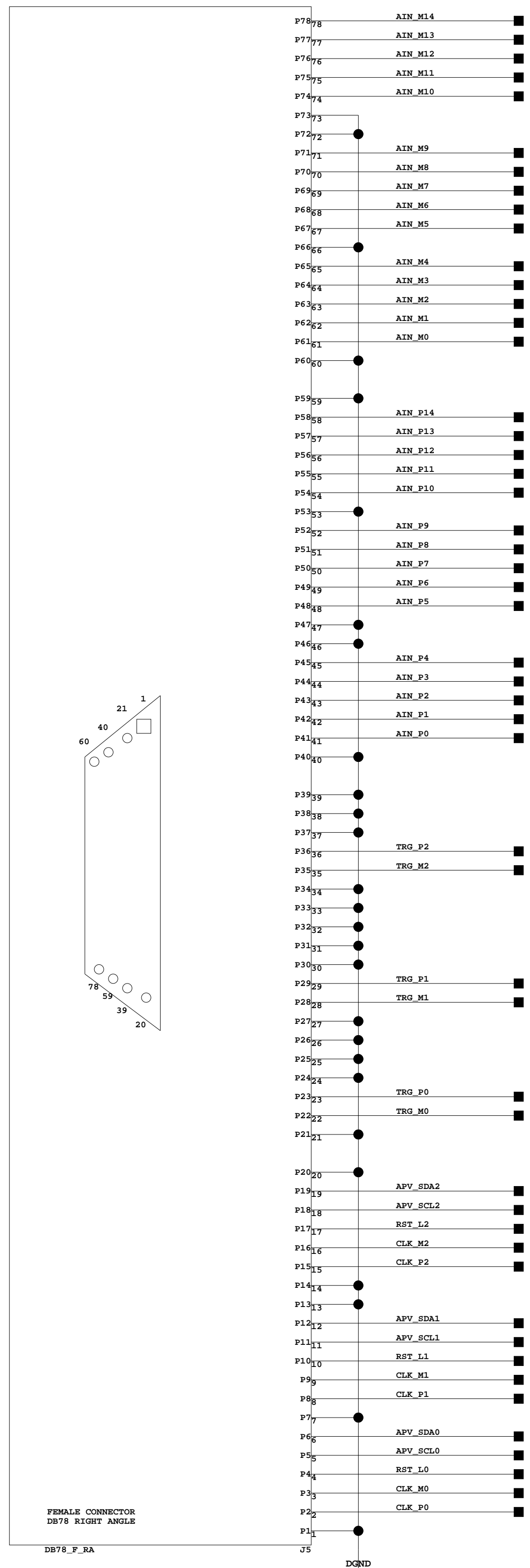

SLAC NATIONAL ACCELERATOR LABORATORY
U.S. DEPARTMENT OF ENERGY

STANFORD UNIVERSITY STANFORD, CALIFORNIA

PROPRIETARY DATA OF STANFORD UNIVERSITY AND/OR U.S. DEPARTMENT OF ENERGY. RECIPIENT SHALL NOT PUBLISH THE INFORMATION WITHIN UNLESS GRANTED SPECIFIC PERMISSION OF STANFORD UNIVERSITY.

DATE	APPROVALS
2010	Ryan Herbst

SHEET 13 OF 23

HEAVY P TRACKER READOUT RTM
APV25 CONNECTOR

LOCATED AT SHEET 1
SD-249-901-02-C01

4-11-2011_15:42

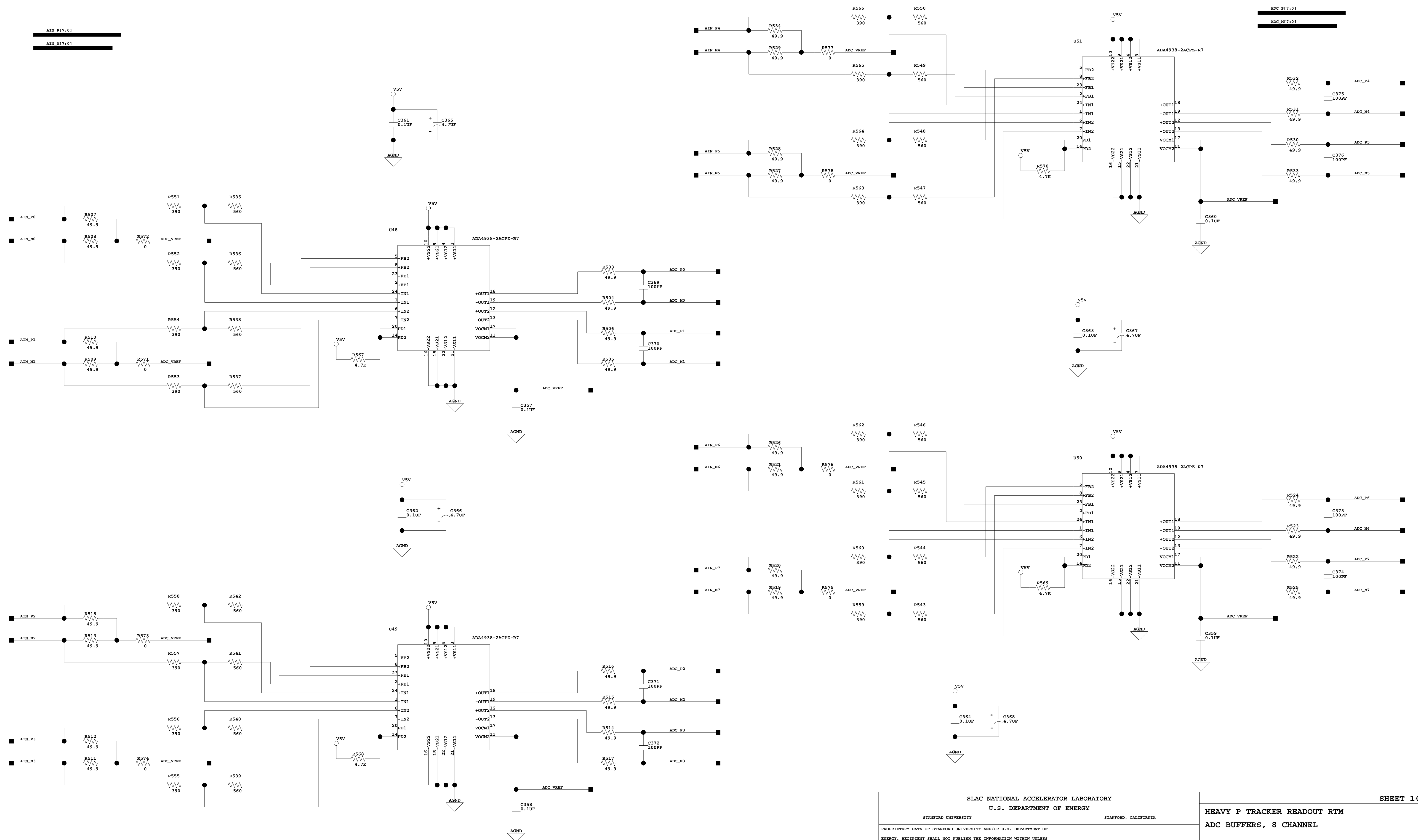

1-24-2011_15:38

SLAC NATIONAL ACCELERATOR LABORATORY U.S. DEPARTMENT OF ENERGY		SHEET 14 OF 23
STANFORD UNIVERSITY STANFORD, CALIFORNIA		HEAVY P TRACKER READOUT RTM ADC BUFFERS, 8 CHANNEL
PROPRIETARY DATA OF STANFORD UNIVERSITY AND/OR U.S. DEPARTMENT OF ENERGY. RECIPIENT SHALL NOT PUBLISH THE INFORMATION WITHIN UNLESS GRANTED SPECIFIC PERMISSION OF STANFORD UNIVERSITY.		
INDR Ryan Herbst DFR CDR	DATE 2010 APPROVALS	
LOCATED AT SHEET 13 SD-249-901-02-C01		

ADC INPUT TERMINATION
PLACE NEAR ADC

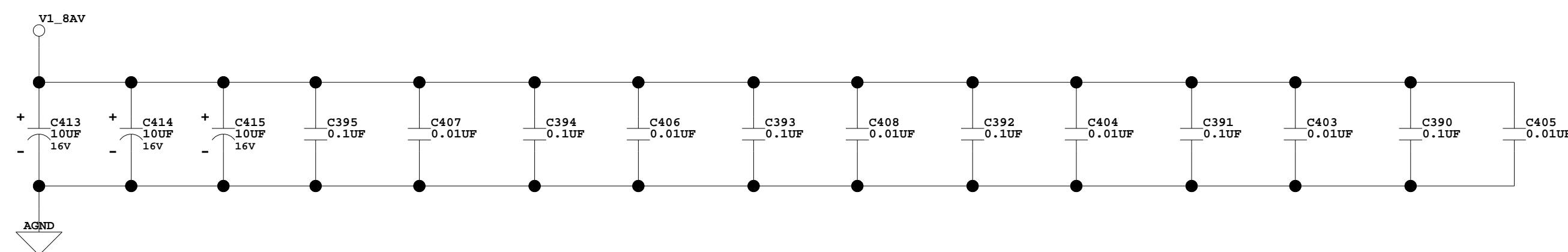
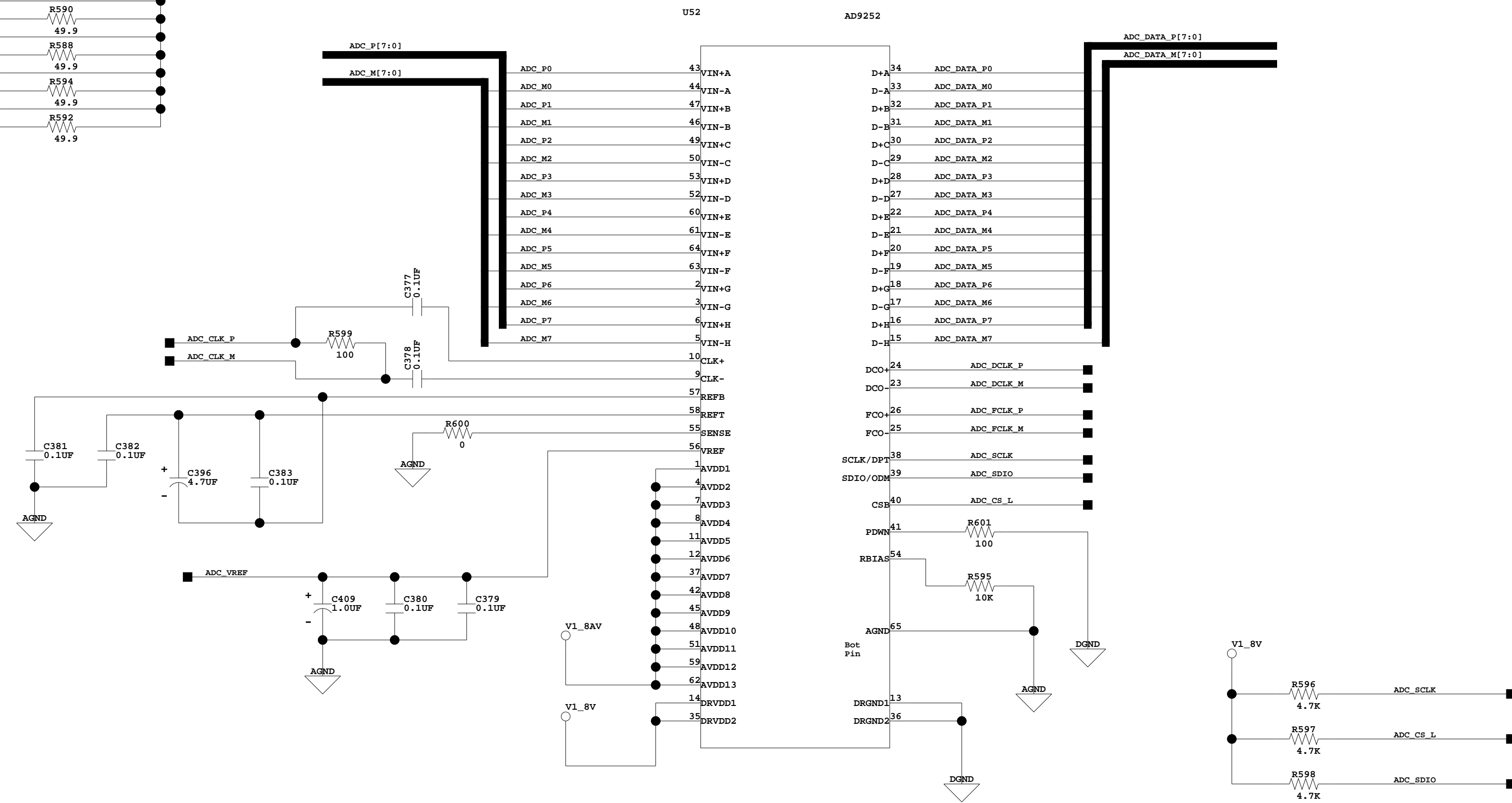
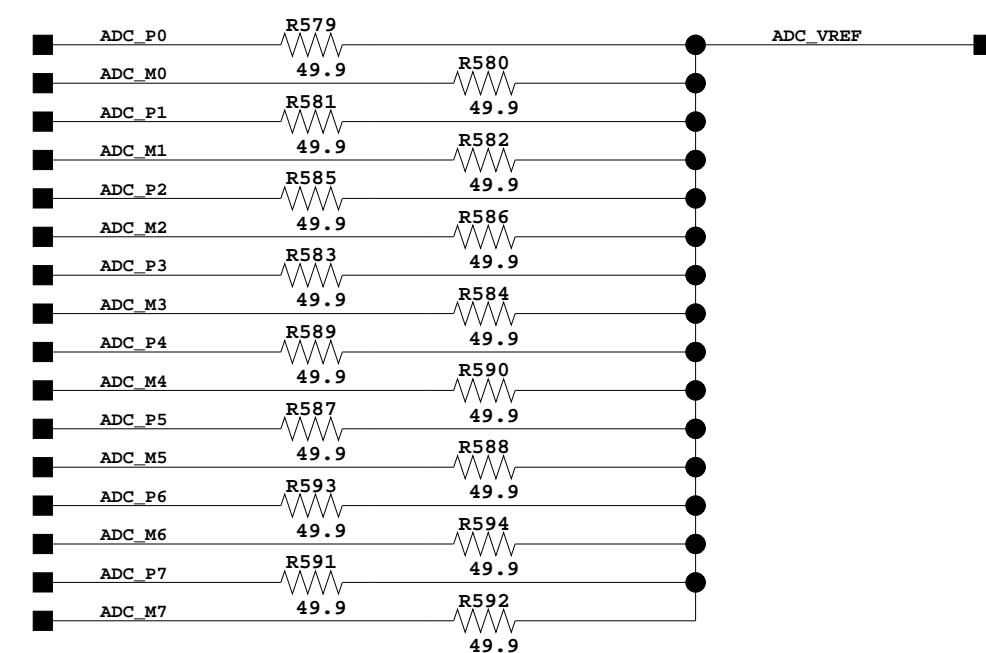

1-24-2011_15:38

SLAC NATIONAL ACCELERATOR LABORATORY U.S. DEPARTMENT OF ENERGY		SHEET 15 OF 23
STANFORD UNIVERSITY STANFORD, CALIFORNIA		HEAVY P TRACKER READOUT RTM 8 CHANNEL ADC
PROPRIETARY DATA OF STANFORD UNIVERSITY AND/OR U.S. DEPARTMENT OF ENERGY. RECIPIENT SHALL NOT PUBLISH THE INFORMATION WITHIN UNLESS GRANTED SPECIFIC PERMISSION OF STANFORD UNIVERSITY.		
INGR	Ryan Herbst	DATE
DPTH		2010
CMR		APPROVALS
		LOCATED AT SHEET 13
		SD-249-901-02-C01

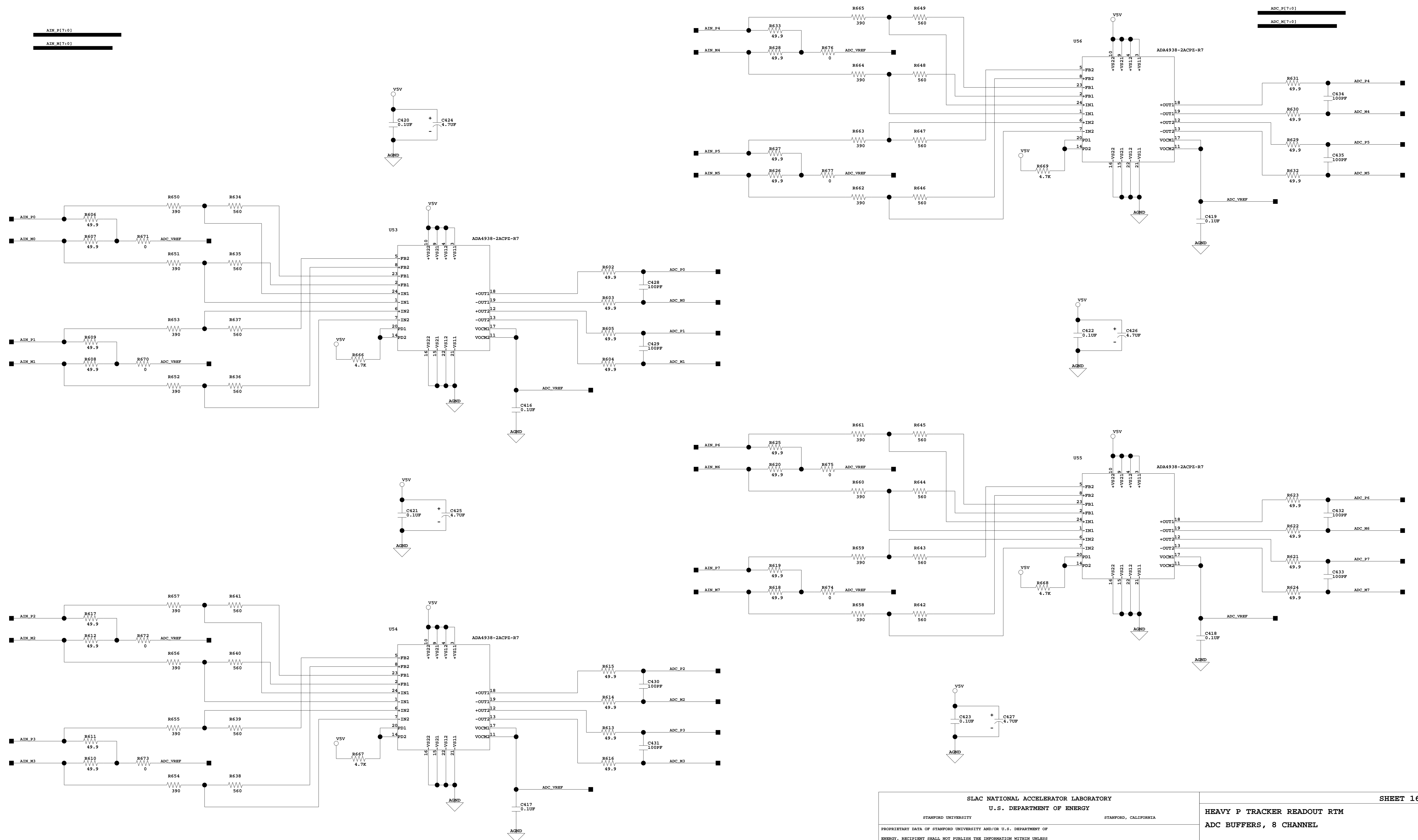

1-24-2011_15:38

SLAC NATIONAL ACCELERATOR LABORATORY U.S. DEPARTMENT OF ENERGY		STANFORD, CALIFORNIA	
PROPRIETARY DATA OF STANFORD UNIVERSITY AND/OR U.S. DEPARTMENT OF ENERGY. RECIPIENT SHALL NOT PUBLISH THE INFORMATION WITHIN UNLESS GRANTED SPECIFIC PERMISSION OF STANFORD UNIVERSITY.		DATE	APPROVALS
DRWR	Ryan Herbst	2010	
DFTR			
CDR			

SHEET 16 OF 23

HEAVY P TRACKER READOUT RTM
ADC BUFFERS, 8 CHANNEL

LOCATED AT SHEET 13

SD-249-901-02-C01

ADC INPUT TERMINATION
PLACE NEAR ADC

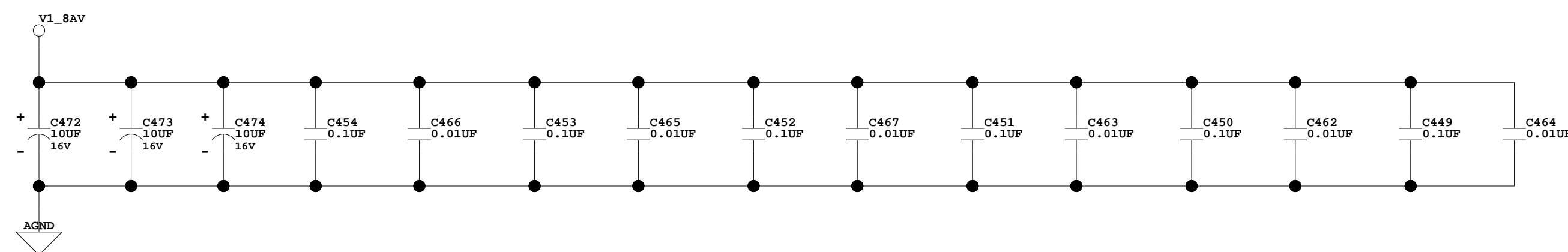
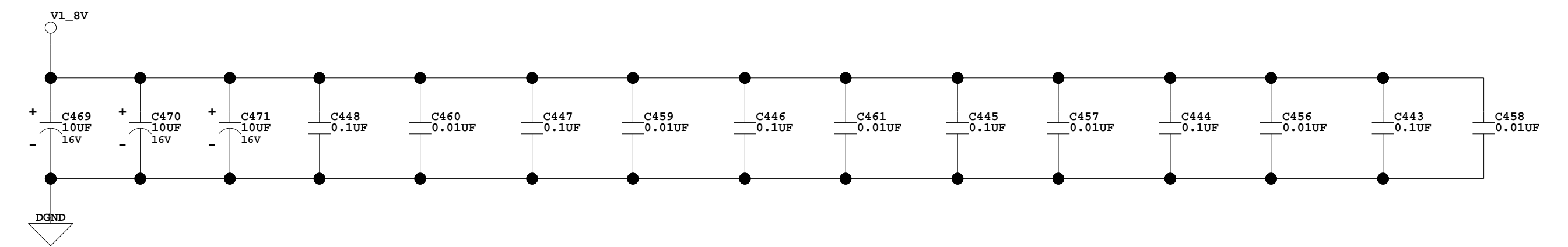
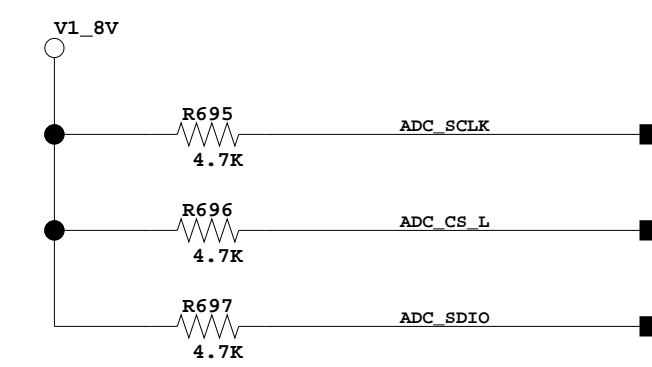
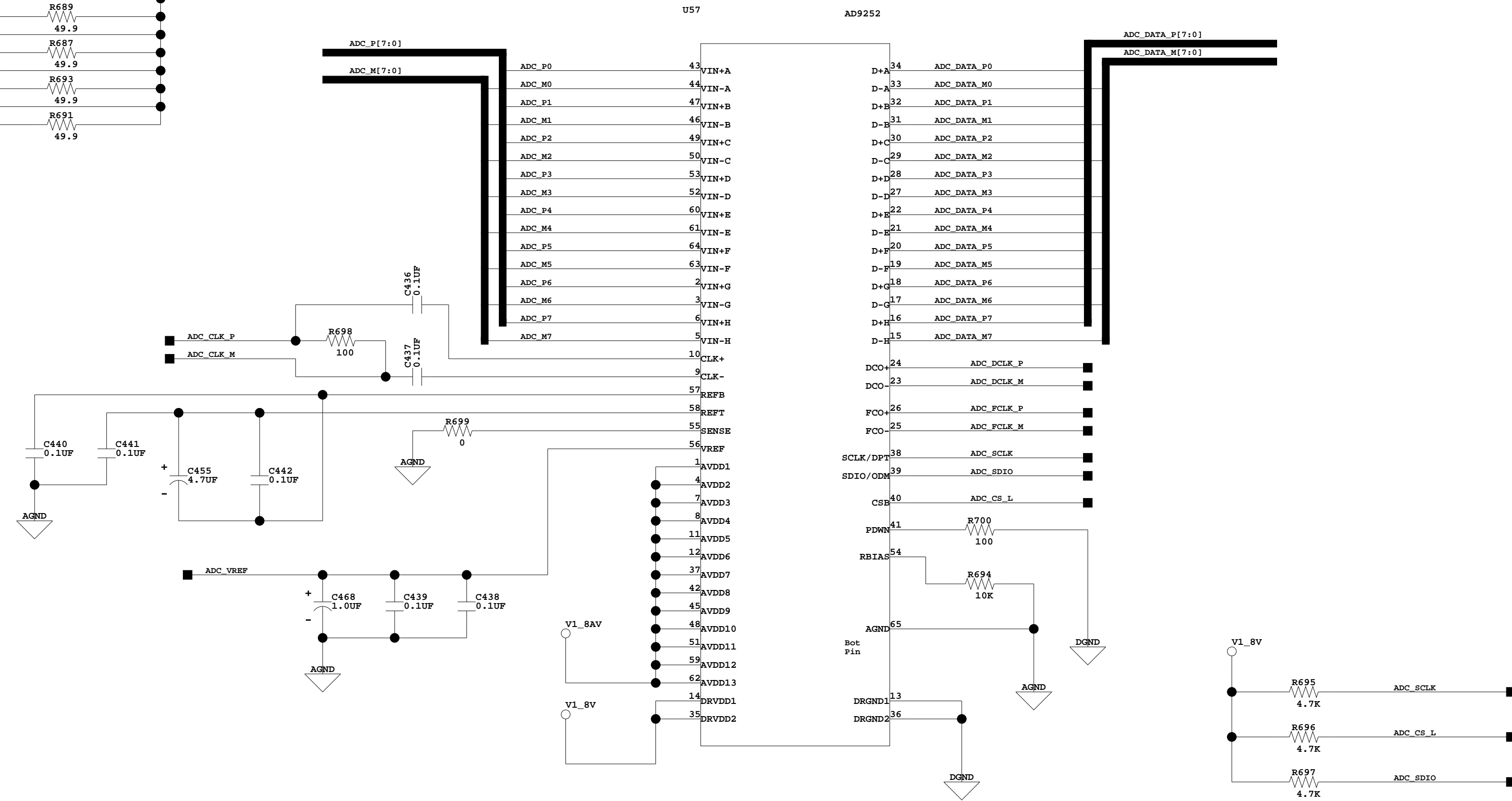
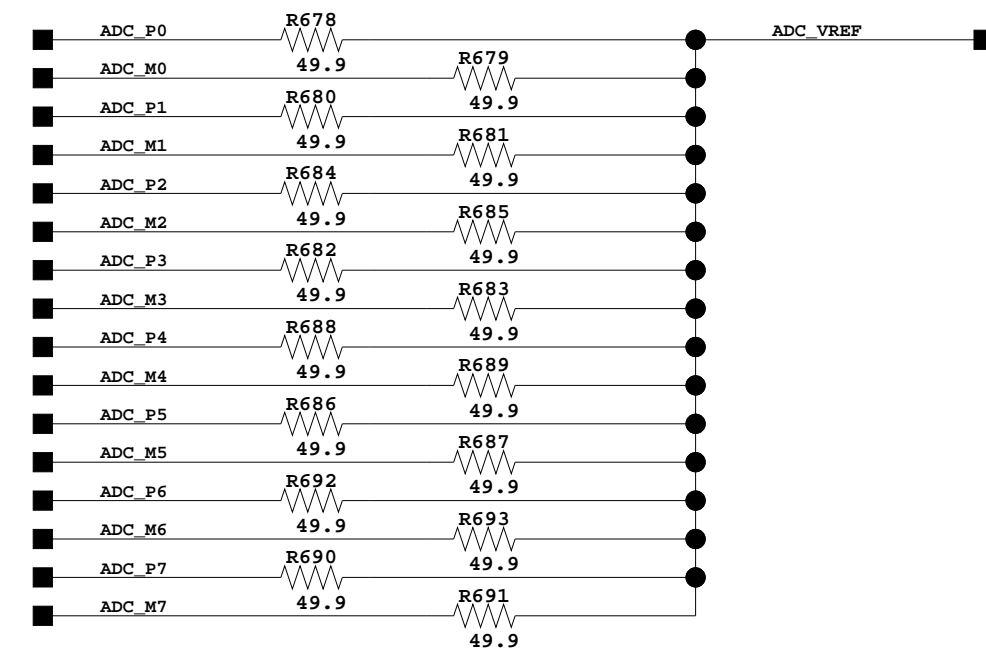

1-24-2011_15:38

SLAC NATIONAL ACCELERATOR LABORATORY U.S. DEPARTMENT OF ENERGY		SHEET 17 OF 23
STANFORD UNIVERSITY STANFORD, CALIFORNIA		HEAVY P TRACKER READOUT RTM 8 CHANNEL ADC
PROPRIETARY DATA OF STANFORD UNIVERSITY AND/OR U.S. DEPARTMENT OF ENERGY. RECIPIENT SHALL NOT PUBLISH THE INFORMATION WITHIN UNLESS GRANTED SPECIFIC PERMISSION OF STANFORD UNIVERSITY.		
INGR Ryan Herbst	DATE 2010	APPROVALS
LOCATED AT SHEET 13 SD-249-901-02-C01		

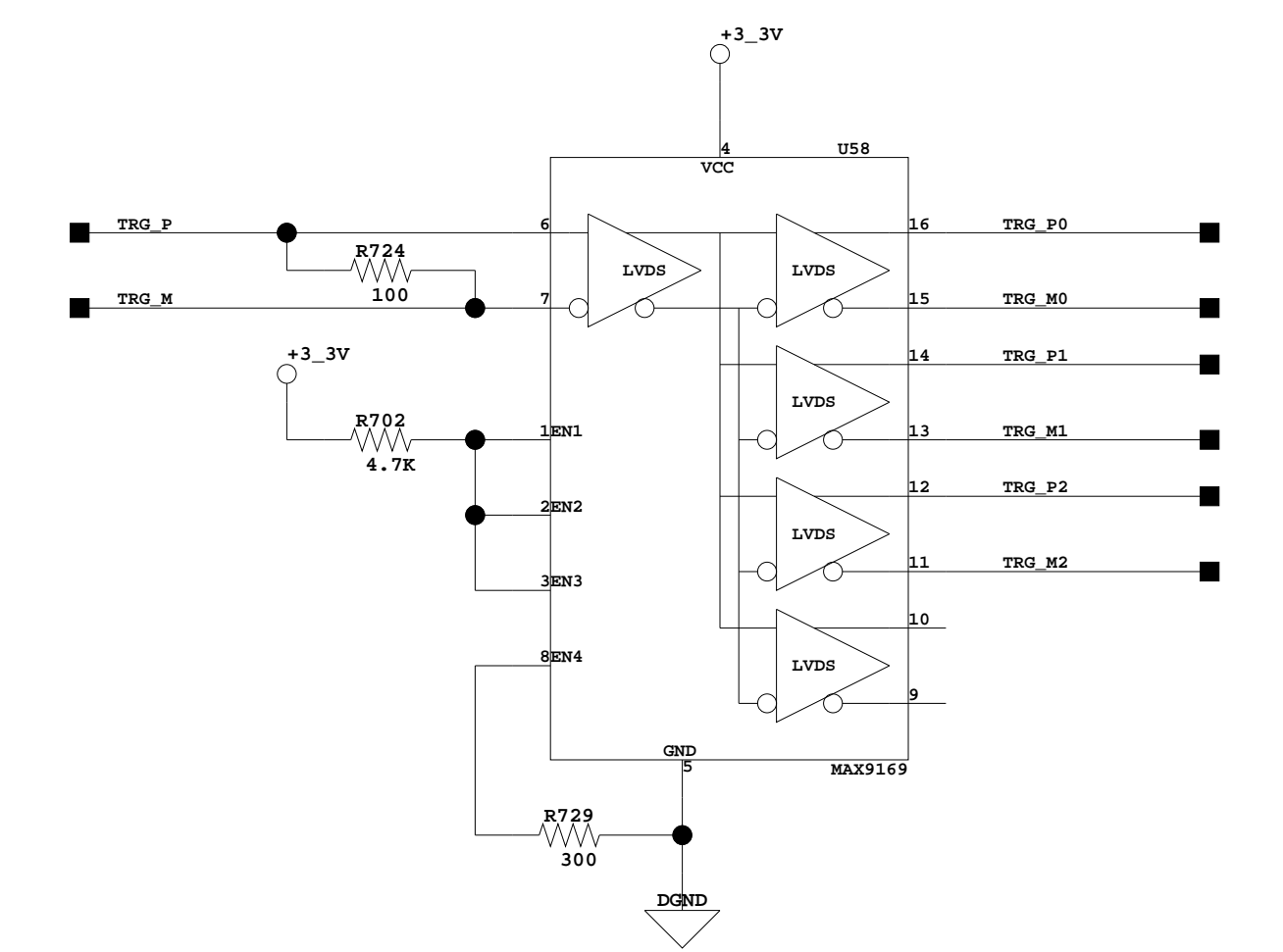
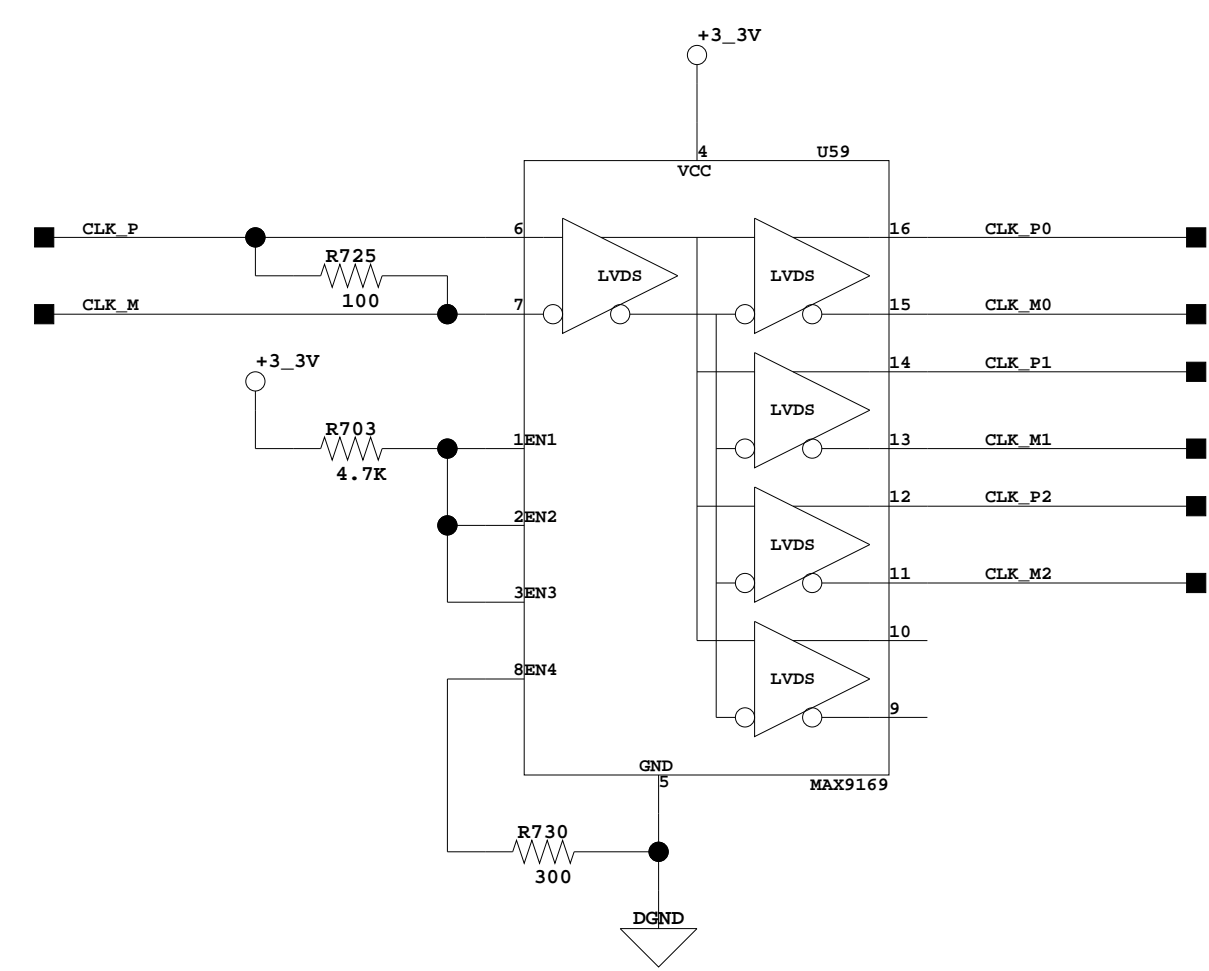
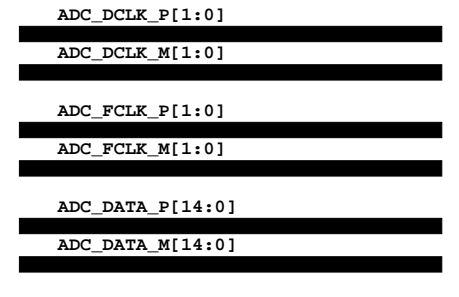
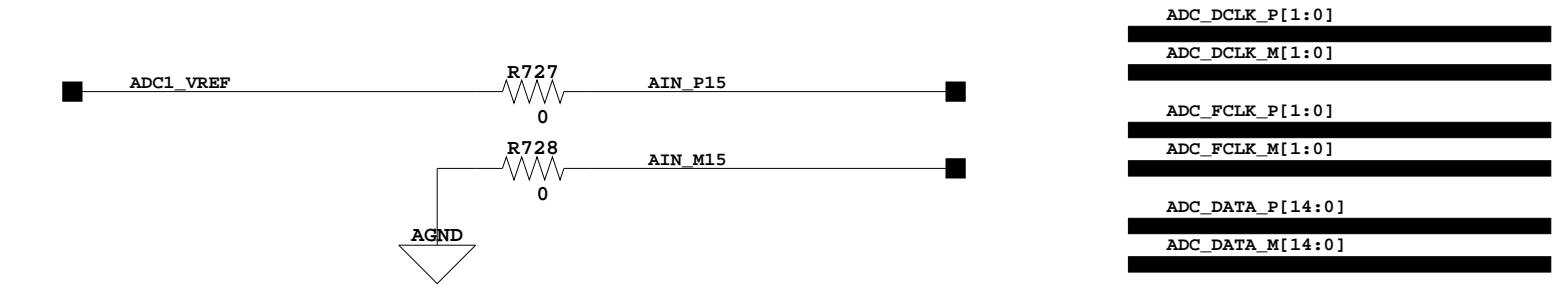
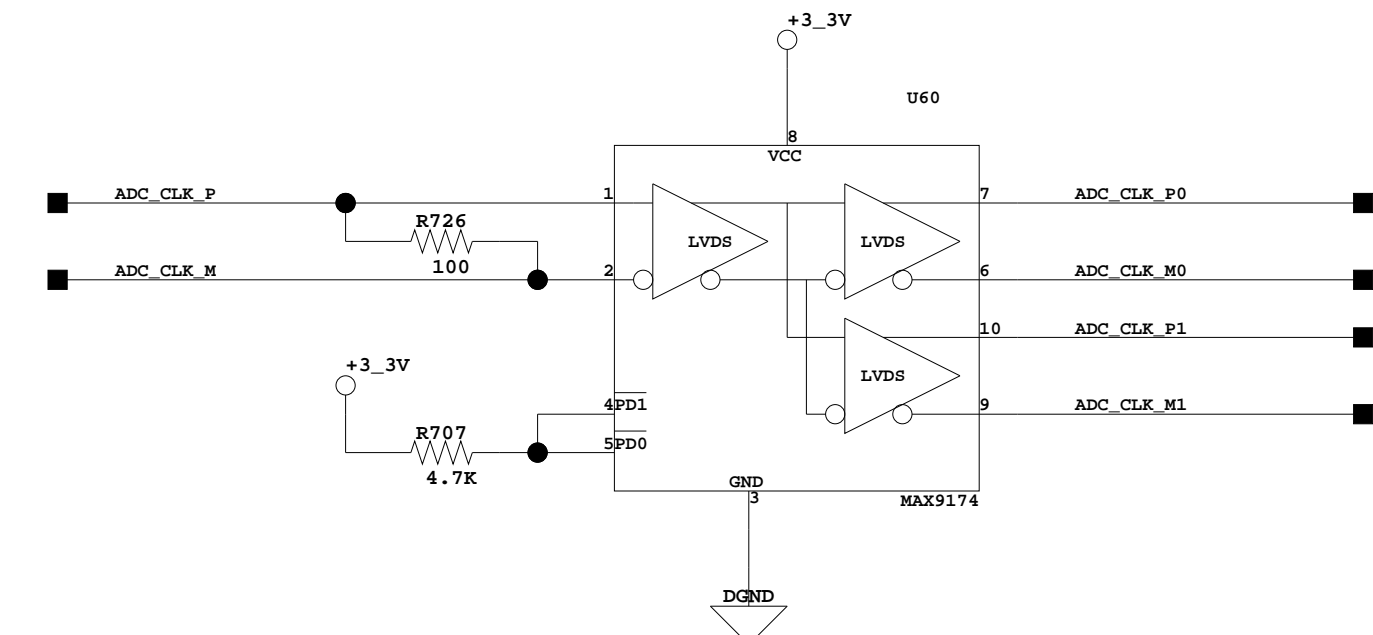
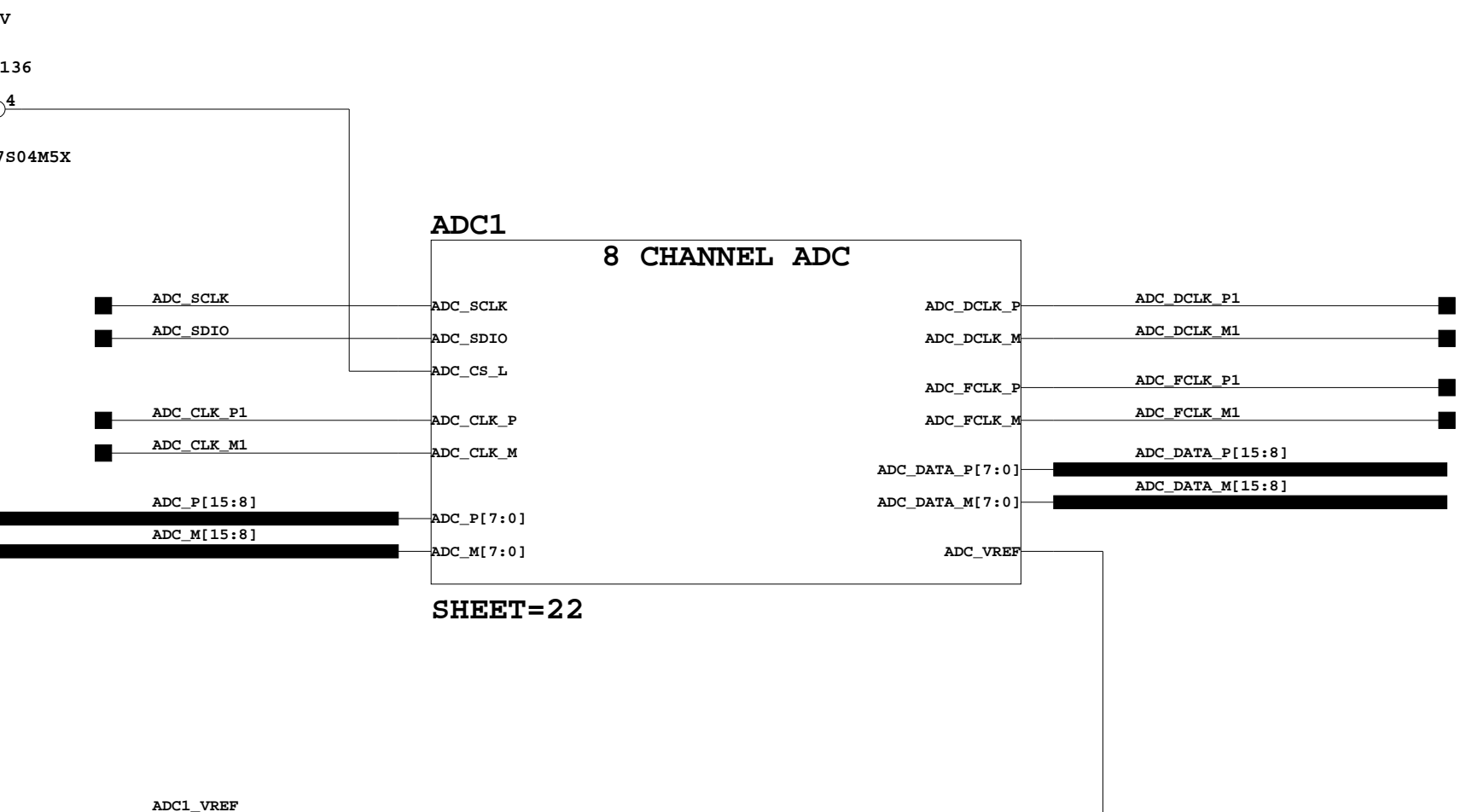
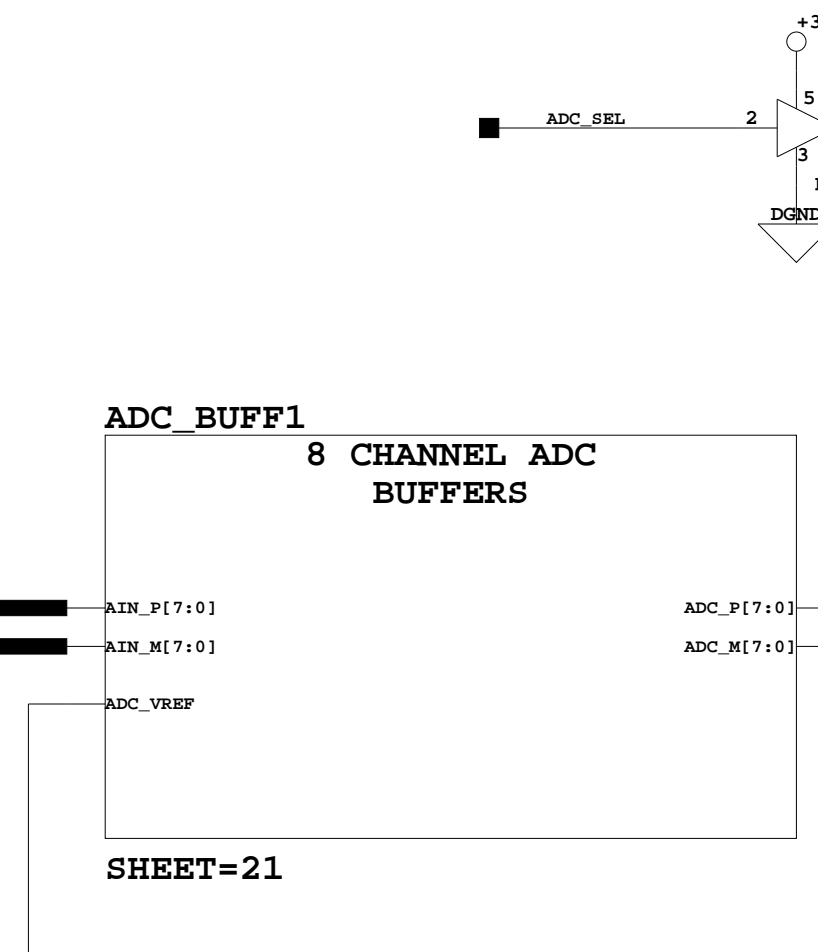
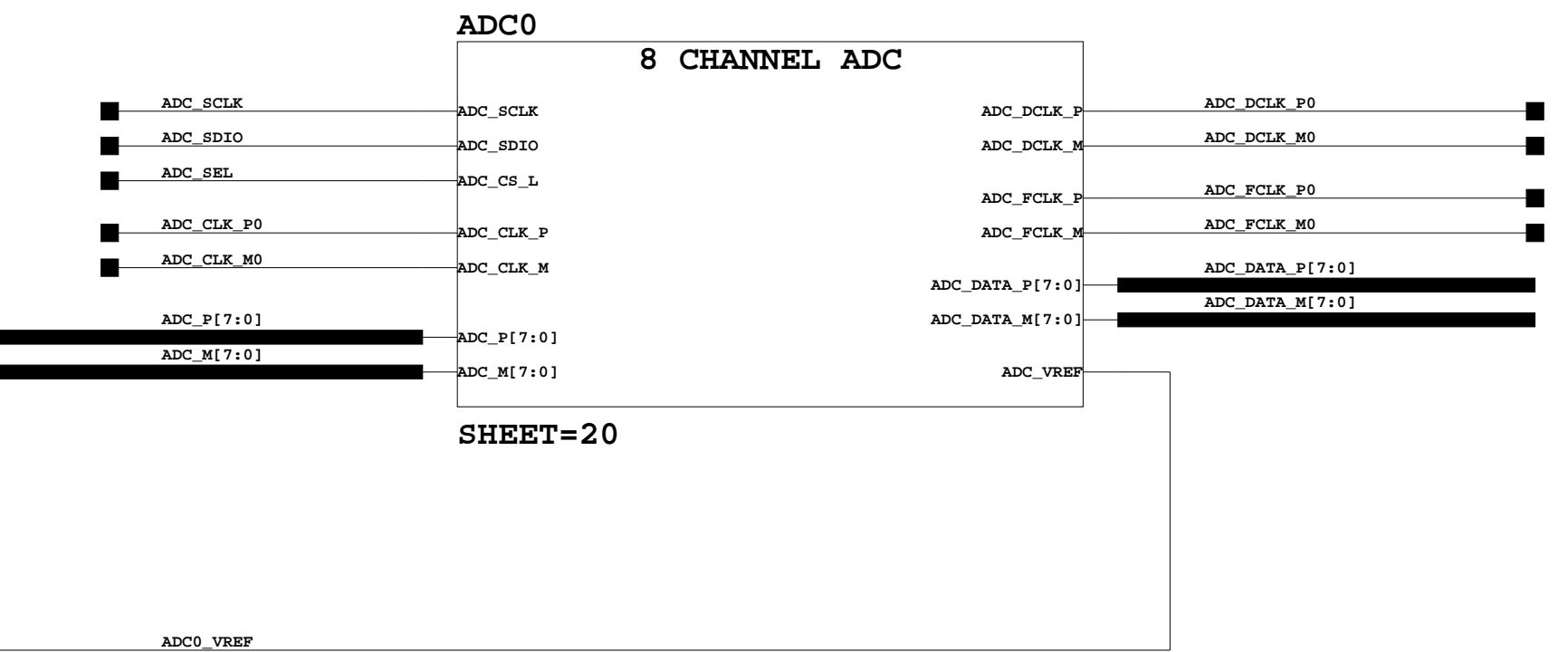
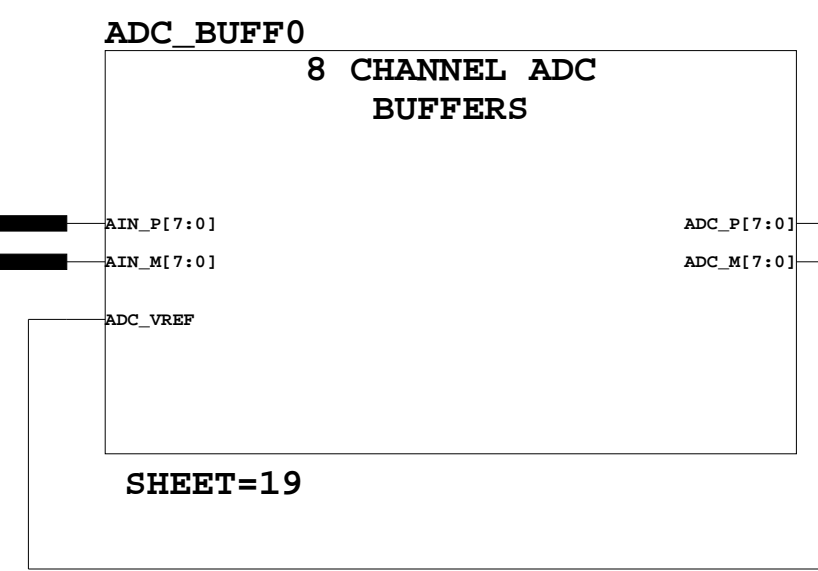
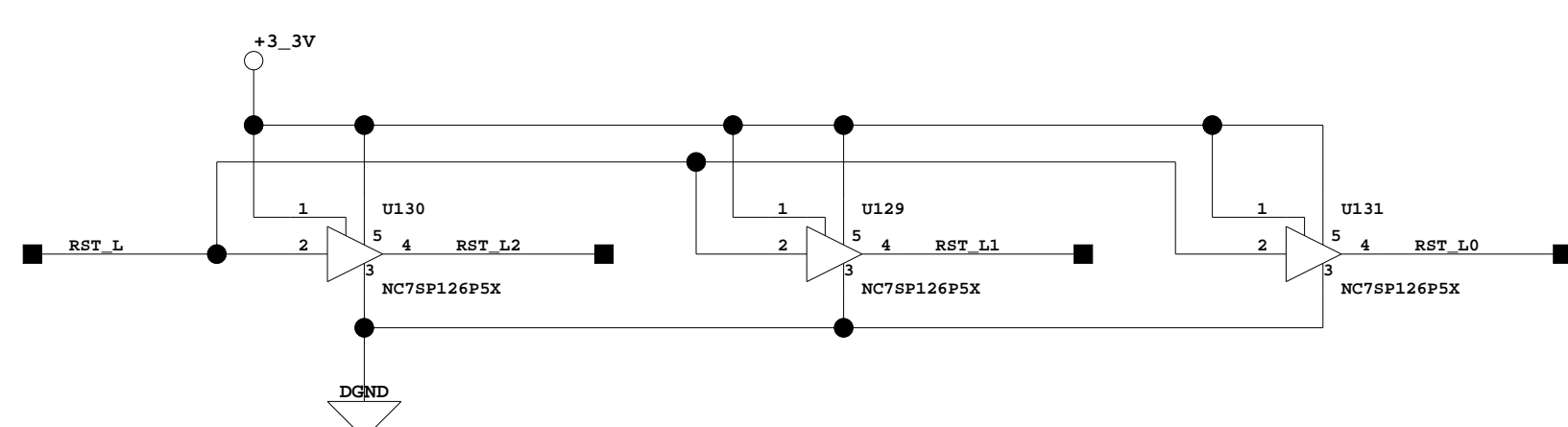
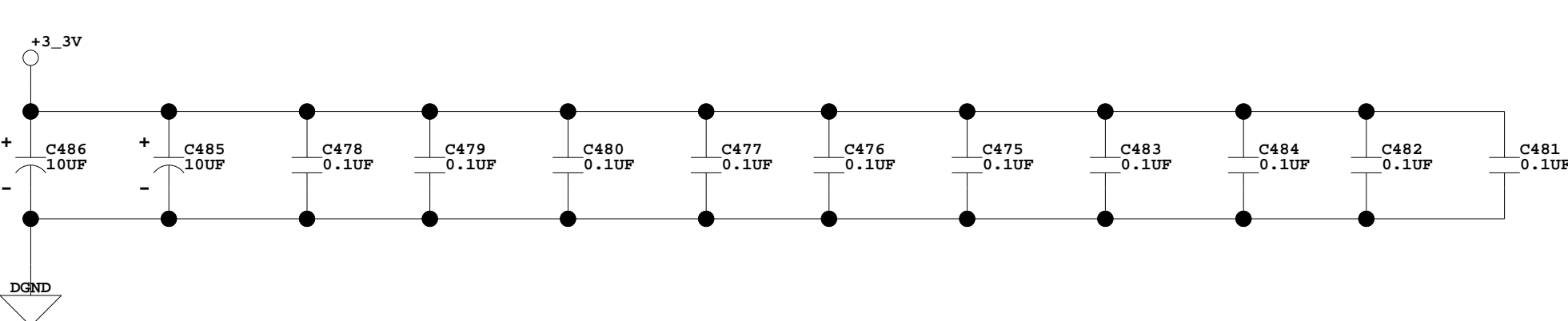
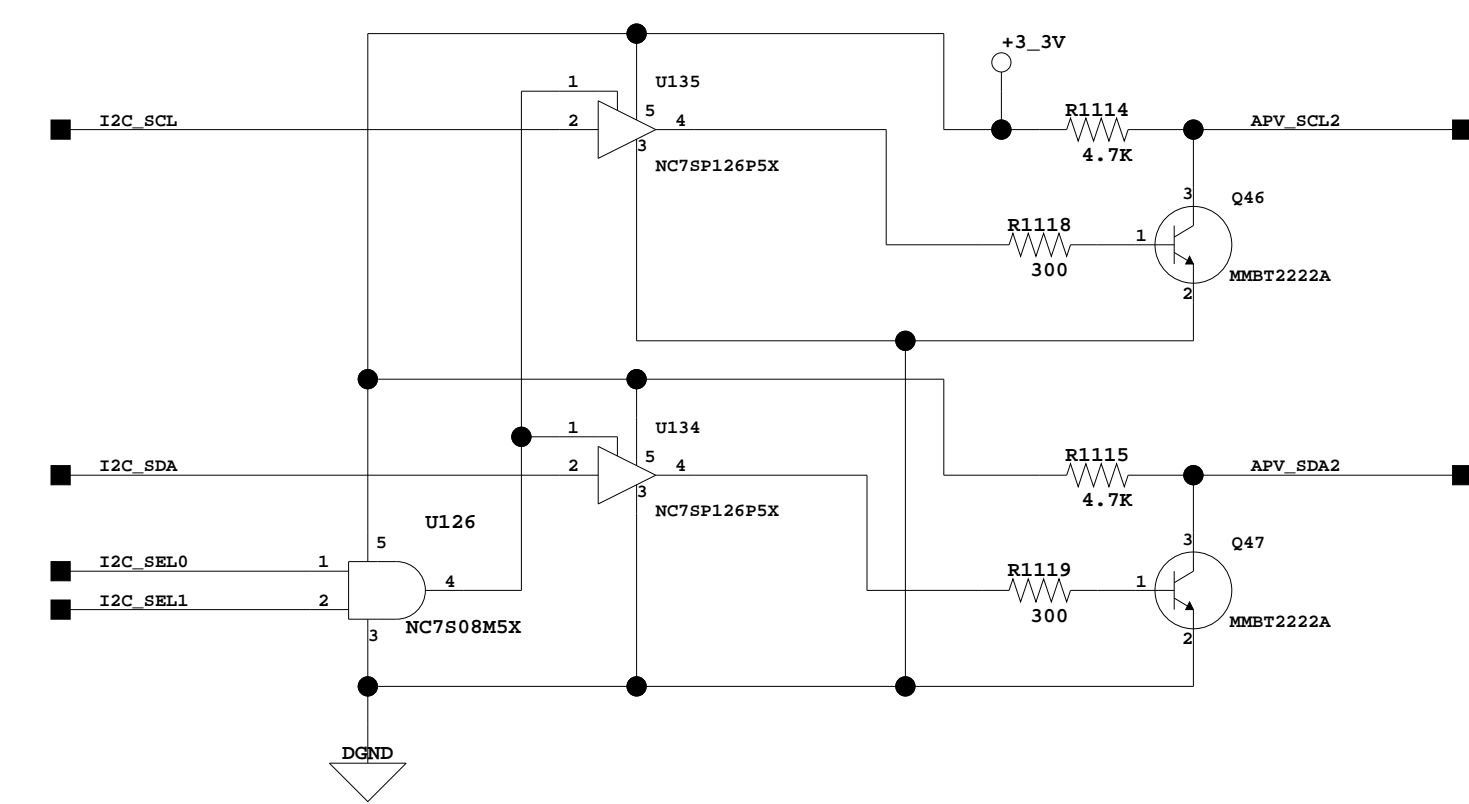
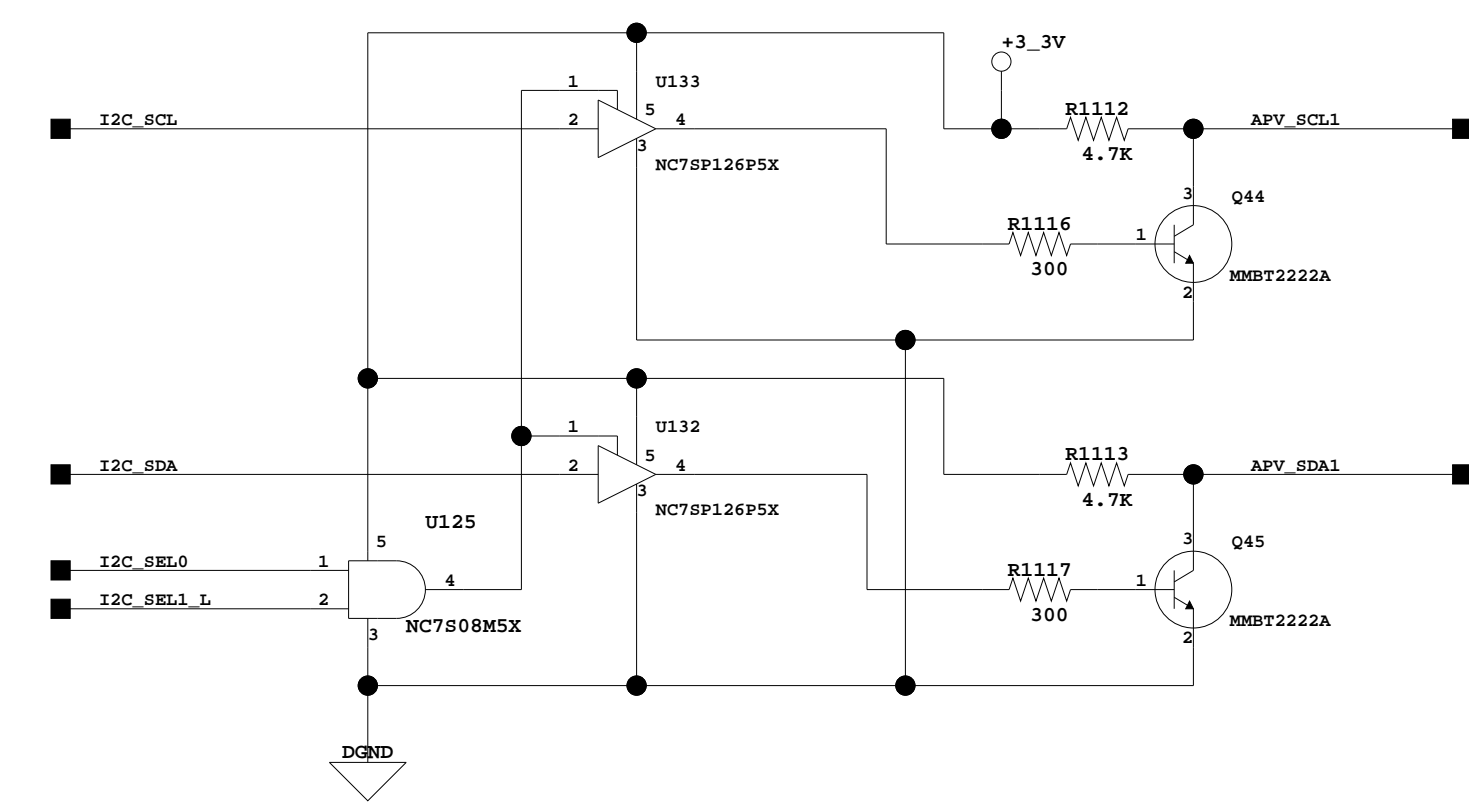
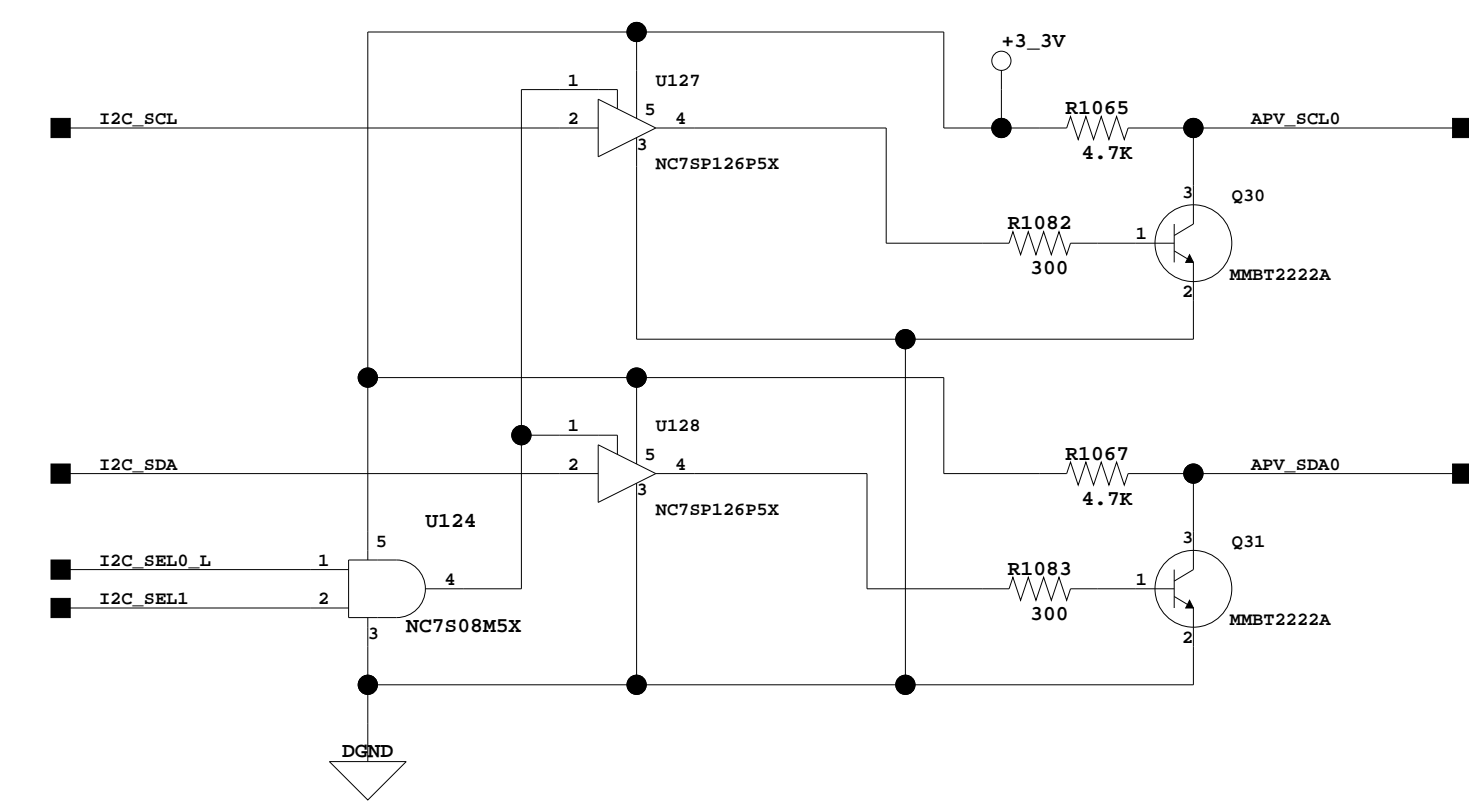
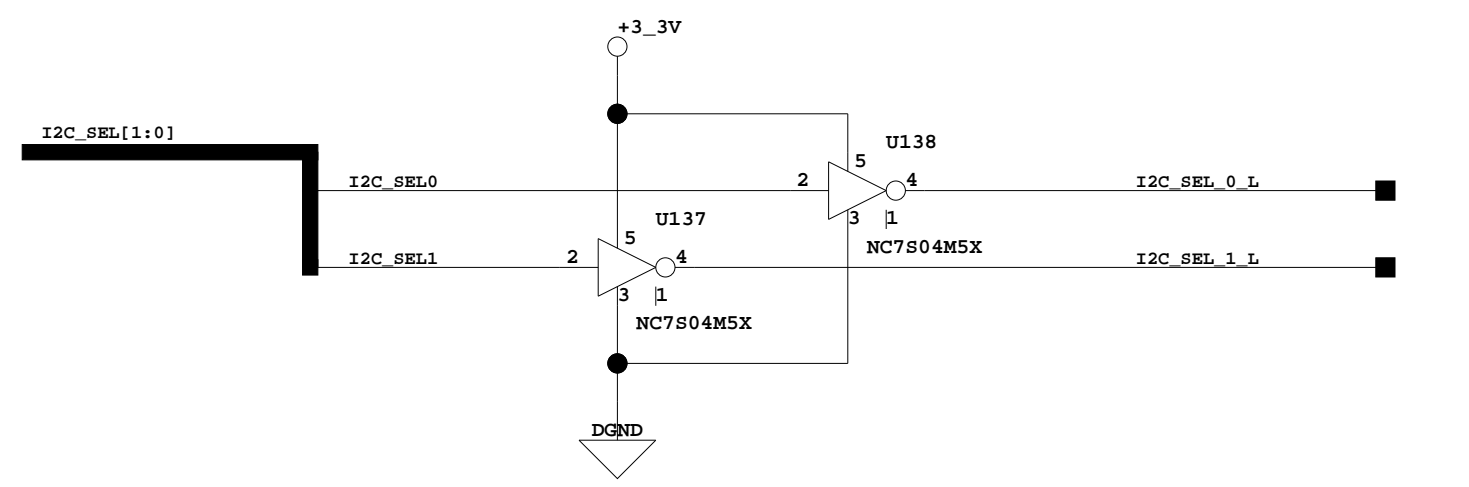
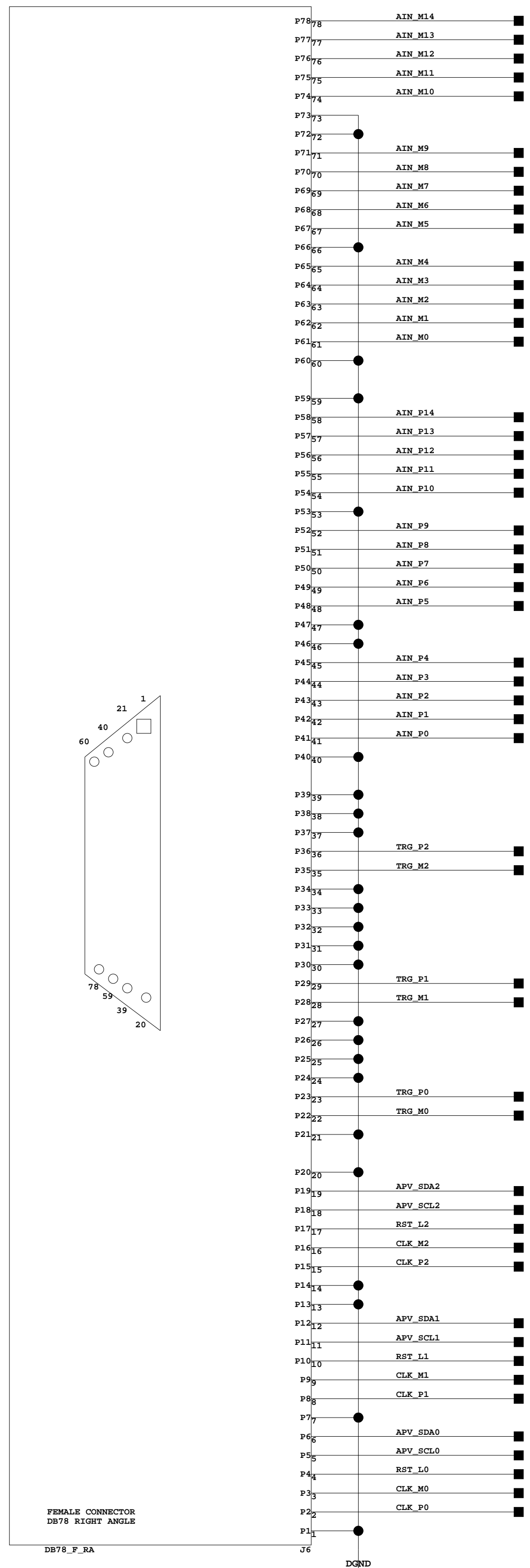

SLAC NATIONAL ACCELERATOR LABORATORY
U.S. DEPARTMENT OF ENERGY

STANFORD UNIVERSITY STANFORD, CALIFORNIA

PROPRIETARY DATA OF STANFORD UNIVERSITY AND/OR U.S. DEPARTMENT OF ENERGY. RECIPIENT SHALL NOT PUBLISH THE INFORMATION WITHIN UNLESS GRANTED SPECIFIC PERMISSION OF STANFORD UNIVERSITY.

DATE	APPROVALS
2010	Ryan Herbst

SHEET 18 OF 23

HEAVY P TRACKER READOUT RTM
APV25 CONNECTOR

LOCATED AT SHEET 1

SD-249-901-02-C01

4-11-2011_15:42

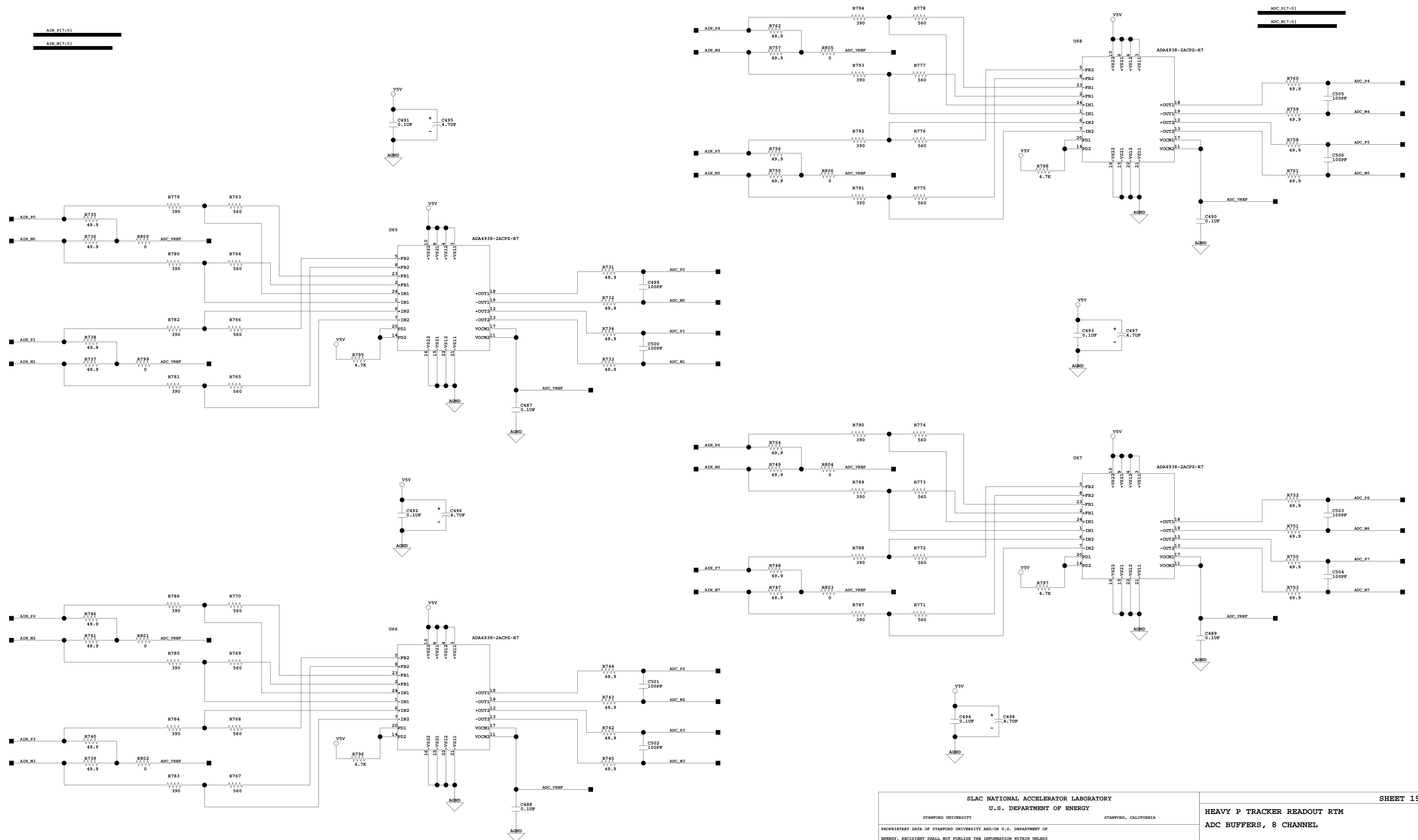

1-24-2011_15:38

SLAC NATIONAL ACCELERATOR LABORATORY
U.S. DEPARTMENT OF ENERGY

STANFORD UNIVERSITY STANFORD, CALIFORNIA

PROPRIETARY DATA OF STANFORD UNIVERSITY AND/OR U.S. DEPARTMENT OF ENERGY. RECIPIENT SHALL NOT PUBLISH THE INFORMATION WITHIN UNLESS GRANTED SPECIFIC PERMISSION OF STANFORD UNIVERSITY.

INCR	DATE	APPROVALS
DRFR	Ryan Herbst	2010
CDR		
INCR		

SHEET 19 OF 23

HEAVY P TRACKER READOUT RTM
ADC BUFFERS, 8 CHANNEL

LOCATED AT SHEET 18
 SD-249-901-02-C01

ADC INPUT TERMINATION
PLACE NEAR ADC

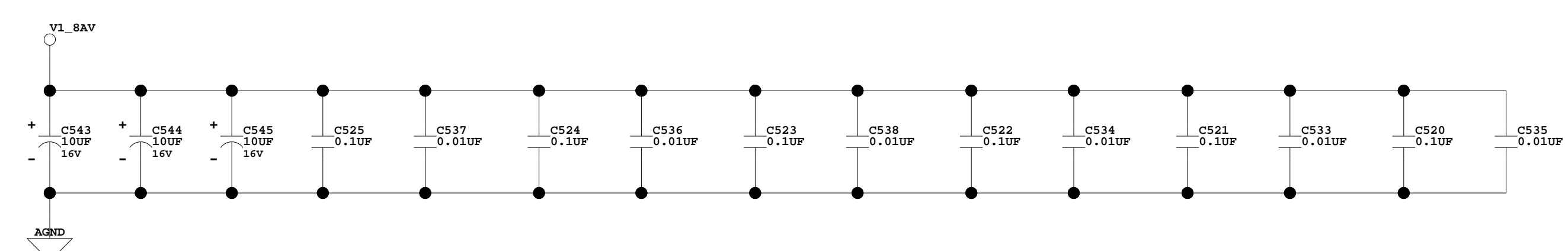
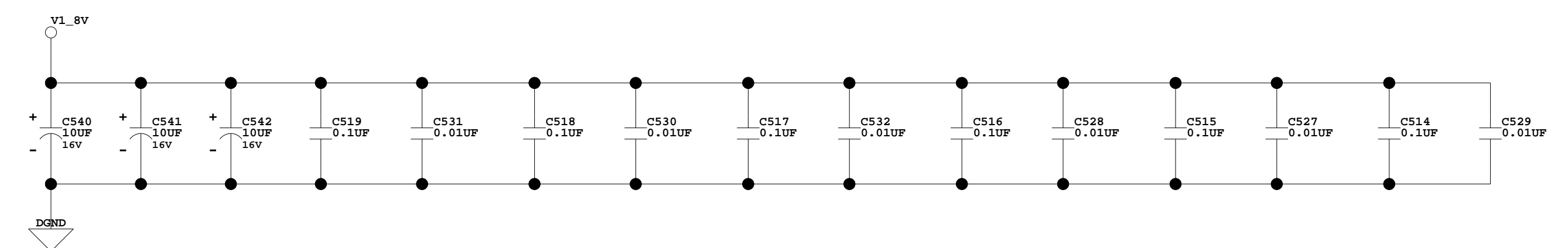
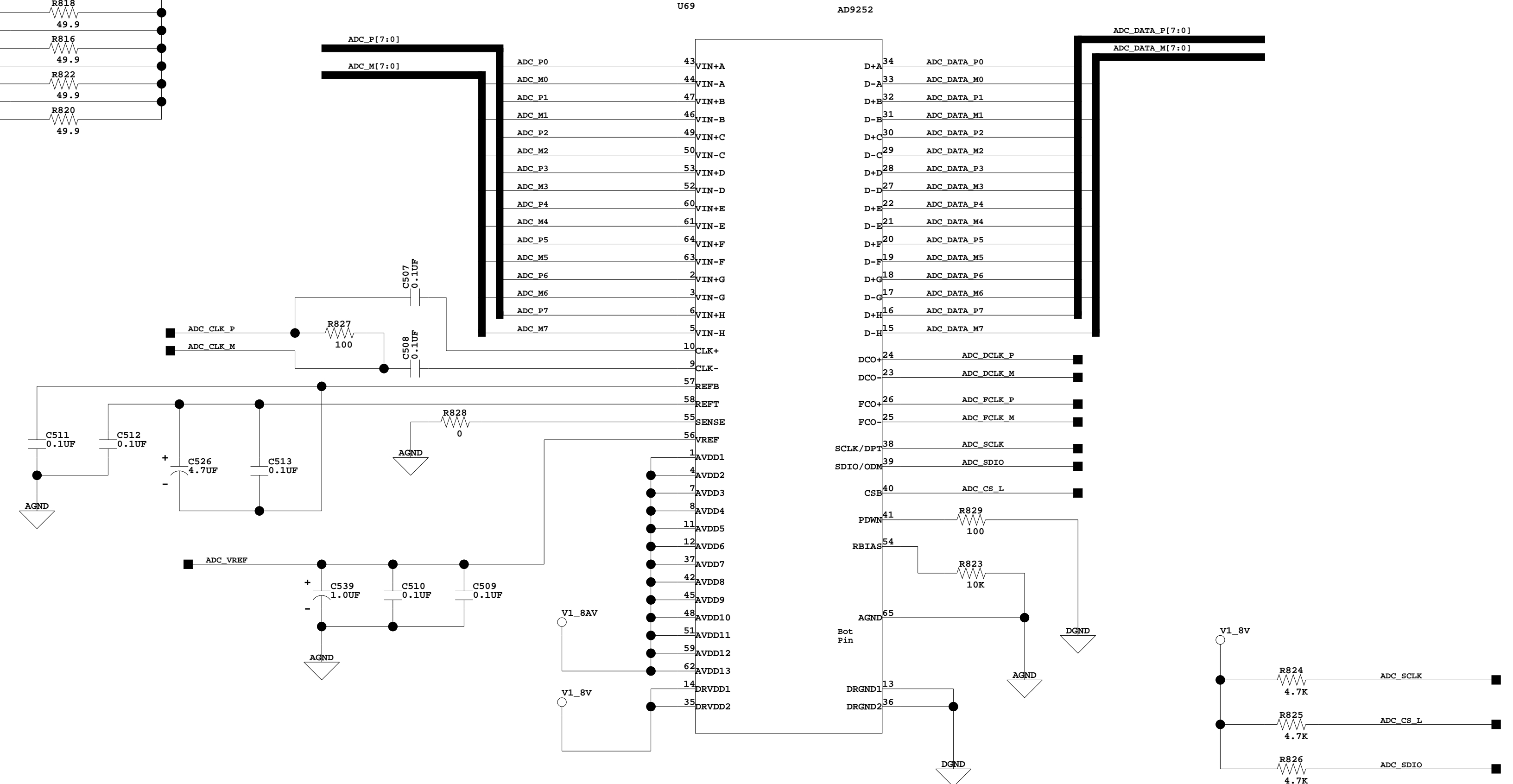
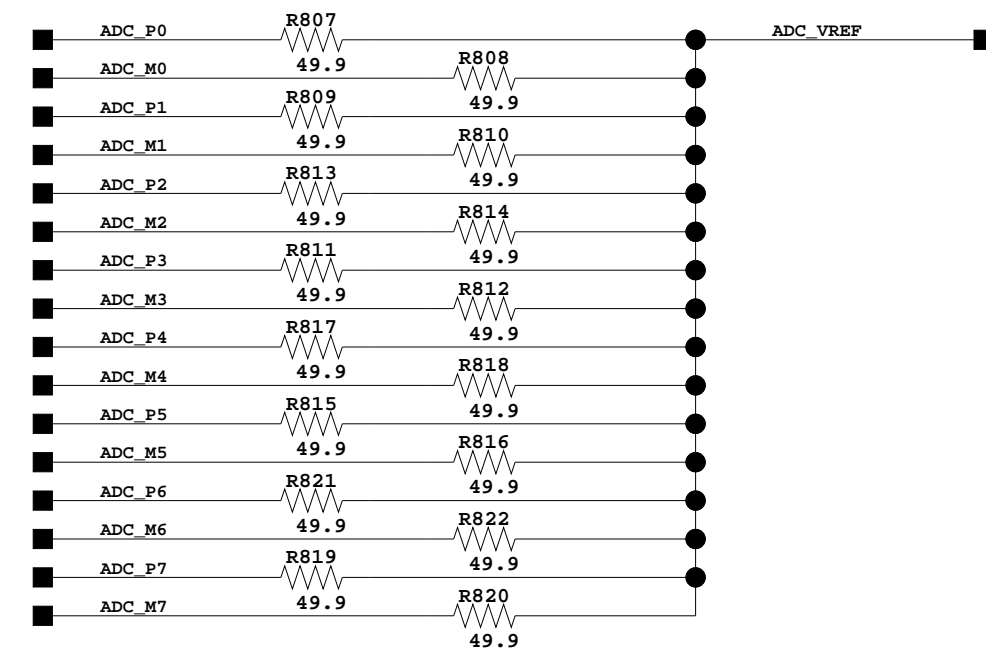

1-24-2011_15:38

SLAC NATIONAL ACCELERATOR LABORATORY U.S. DEPARTMENT OF ENERGY		SHEET 20 OF 23
STANFORD UNIVERSITY STANFORD, CALIFORNIA		HEAVY P TRACKER READOUT RTM 8 CHANNEL ADC
PROPRIETARY DATA OF STANFORD UNIVERSITY AND/OR U.S. DEPARTMENT OF ENERGY. RECIPIENT SHALL NOT PUBLISH THE INFORMATION WITHIN UNLESS GRANTED SPECIFIC PERMISSION OF STANFORD UNIVERSITY.		
INGR Ryan Herbst	DATE 2010	APPROVALS
LOCATED AT SHEET 18		
SD-249-901-02-C01		

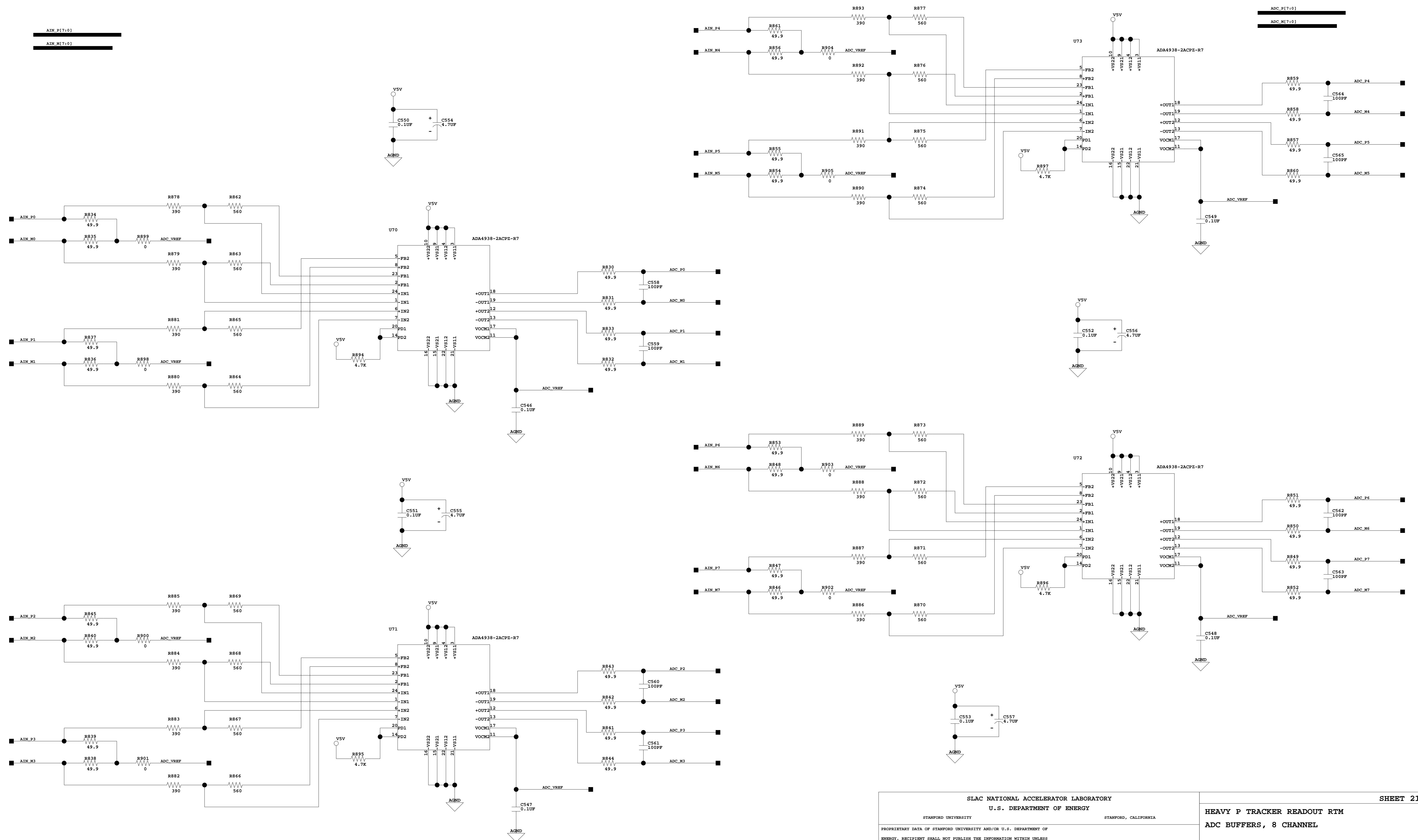

1-24-2011_15:38

SLAC NATIONAL ACCELERATOR LABORATORY
U.S. DEPARTMENT OF ENERGY

STANFORD UNIVERSITY STANFORD, CALIFORNIA

PROPRIETARY DATA OF STANFORD UNIVERSITY AND/OR U.S. DEPARTMENT OF ENERGY. RECIPIENT SHALL NOT PUBLISH THE INFORMATION WITHIN UNLESS GRANTED SPECIFIC PERMISSION OF STANFORD UNIVERSITY.

INCR	DATE	APPROVALS
0001	2010	
0002		
0003		

SHEET 21 OF 23

HEAVY P TRACKER READOUT RTM
ADC BUFFERS, 8 CHANNEL

LOCATED AT SHEET 18

SD-249-901-02-C01

**ADC INPUT TERMINATION
PLACE NEAR ADC**

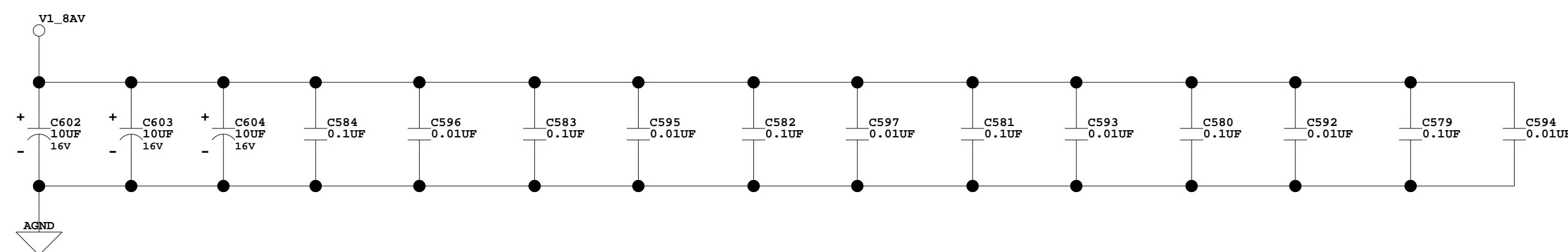
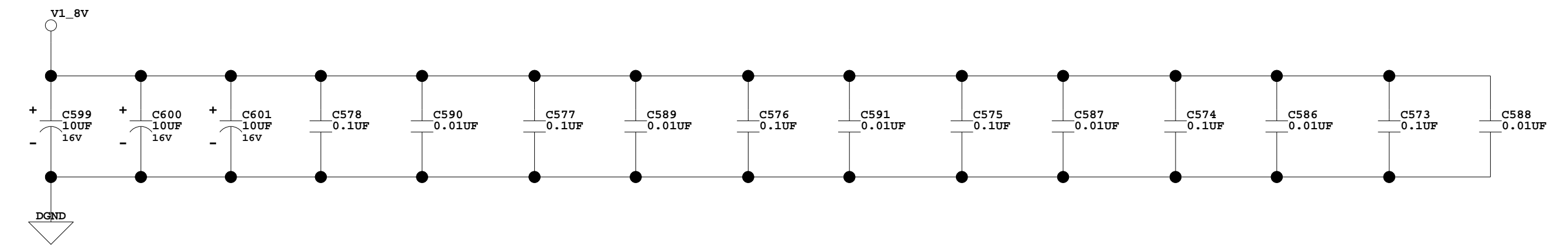
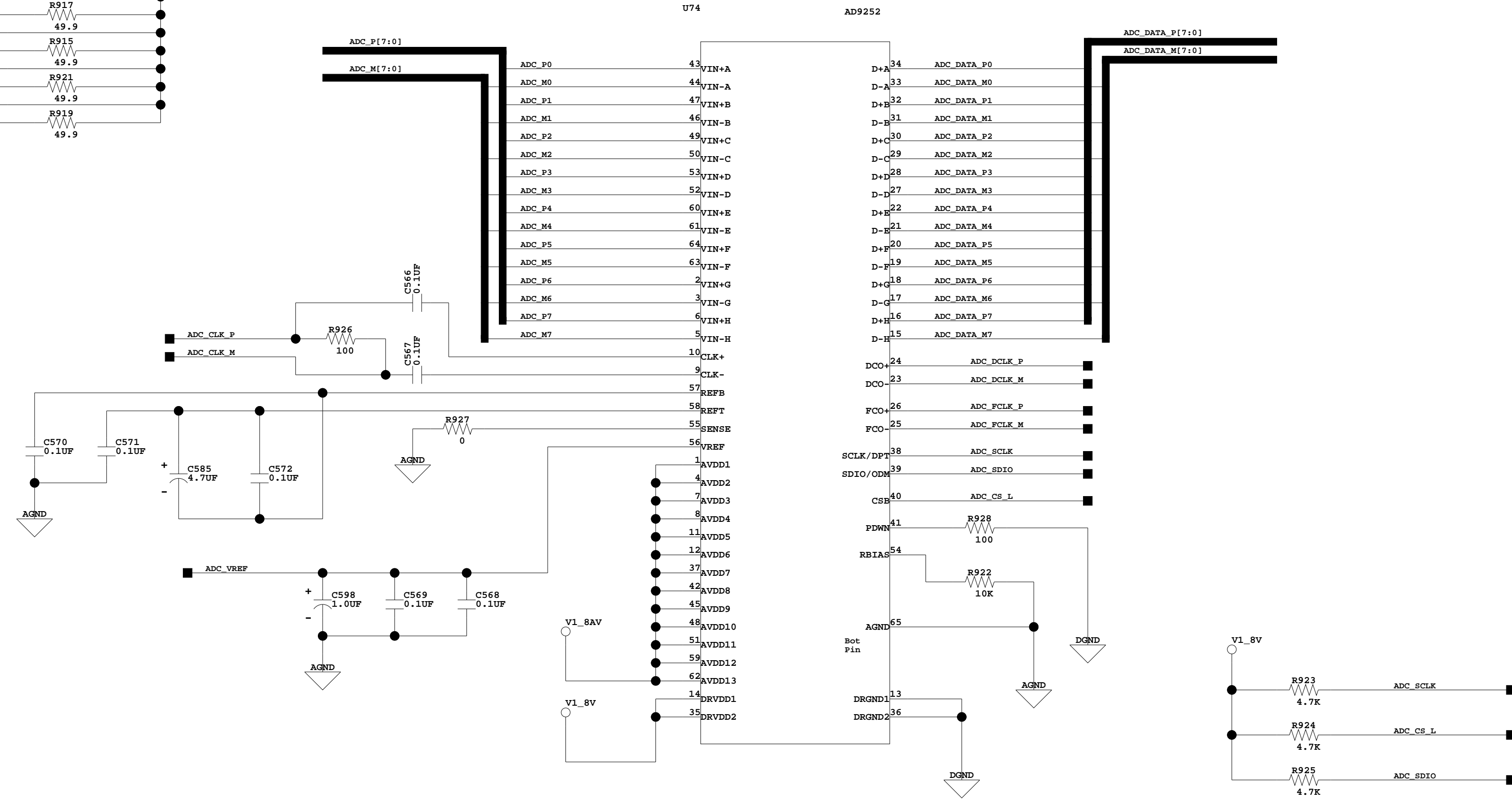
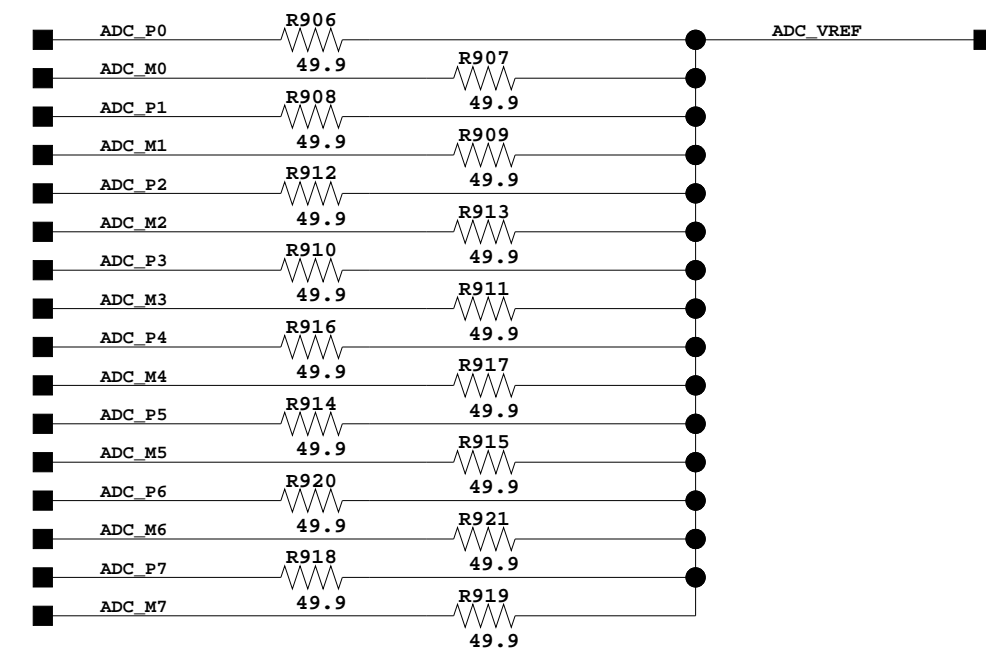

1-24-2011_15:38

SLAC NATIONAL ACCELERATOR LABORATORY U.S. DEPARTMENT OF ENERGY		SHEET 22 OF 23
STANFORD UNIVERSITY STANFORD, CALIFORNIA		HEAVY P TRACKER READOUT RTM 8 CHANNEL ADC
PROPRIETARY DATA OF STANFORD UNIVERSITY AND/OR U.S. DEPARTMENT OF ENERGY. RECIPIENT SHALL NOT PUBLISH THE INFORMATION WITHIN UNLESS GRANTED SPECIFIC PERMISSION OF STANFORD UNIVERSITY.		
INGR DPTH CMR	Ryan Herbat 2010	APPROVALS
LOCATED AT SHEET 18		SD-249-901-02-C01

LEDS

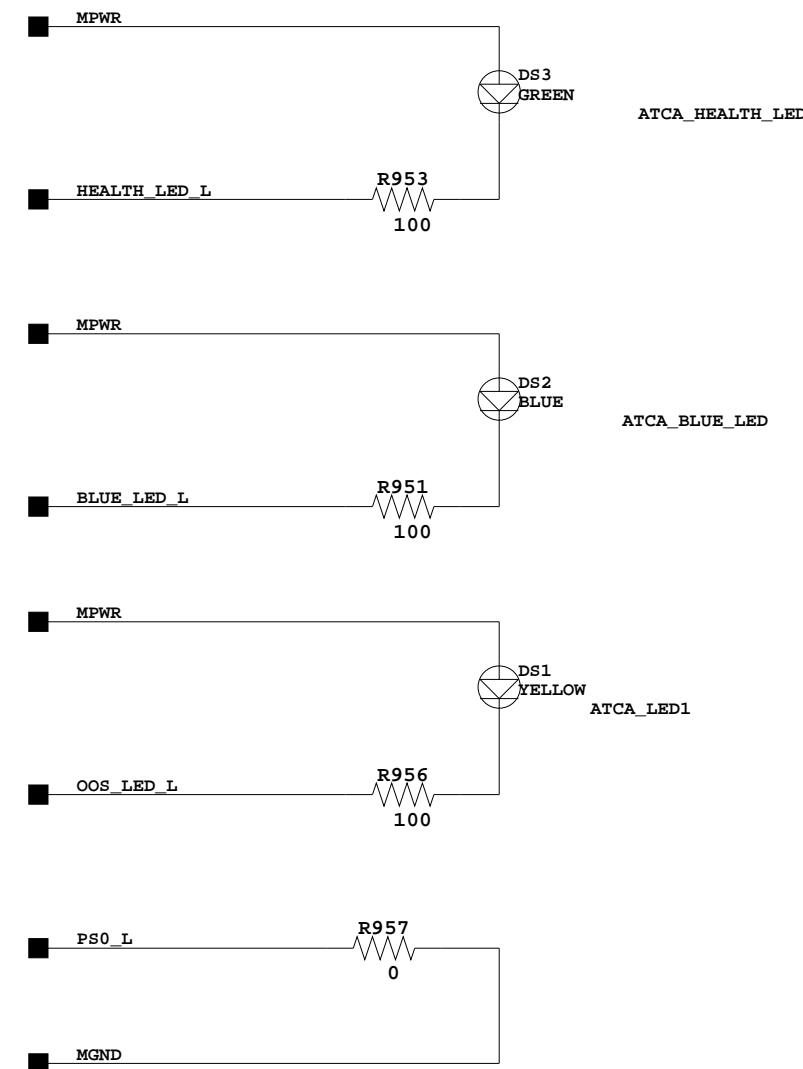

VOLTAGE MONITOR

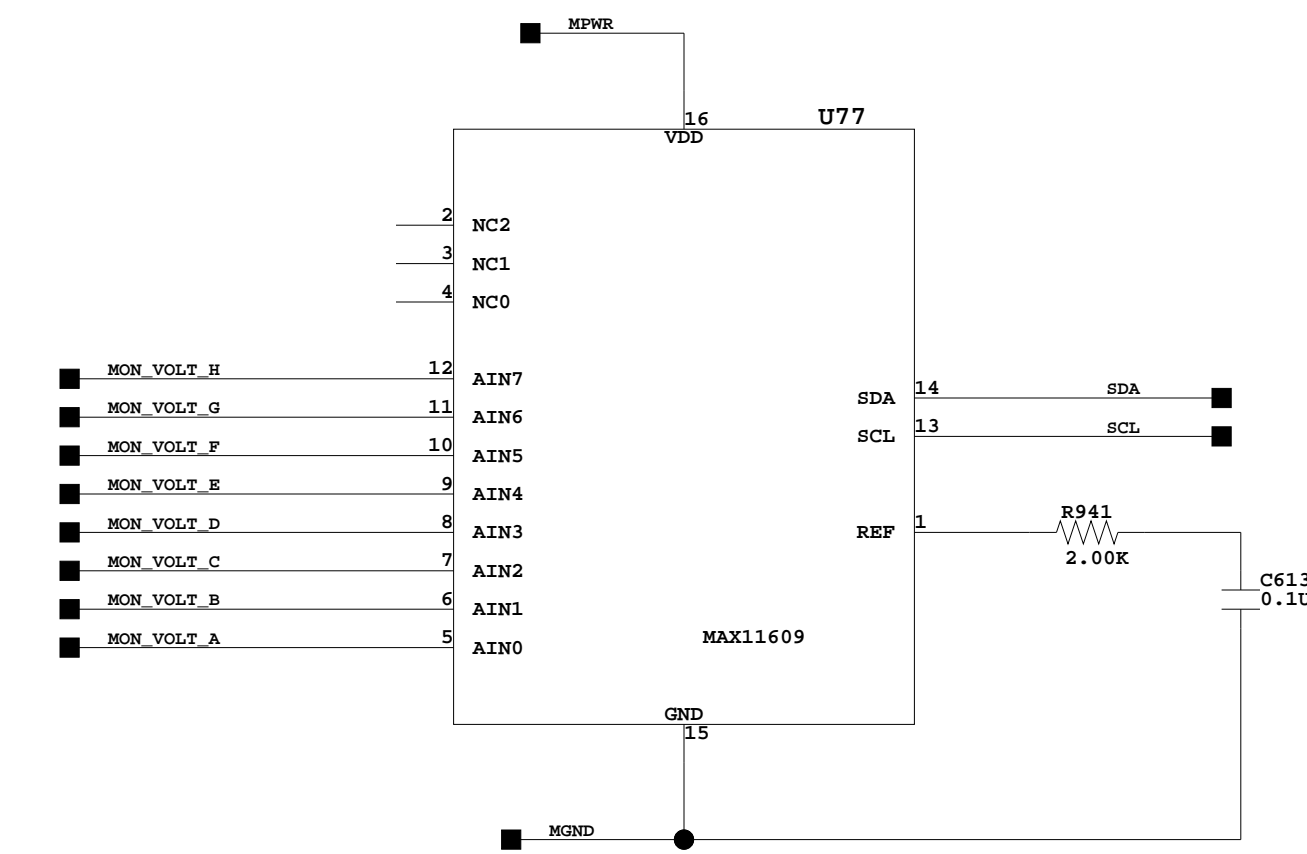

ADDR = 0x3C

TEMPERATURE SENSOR

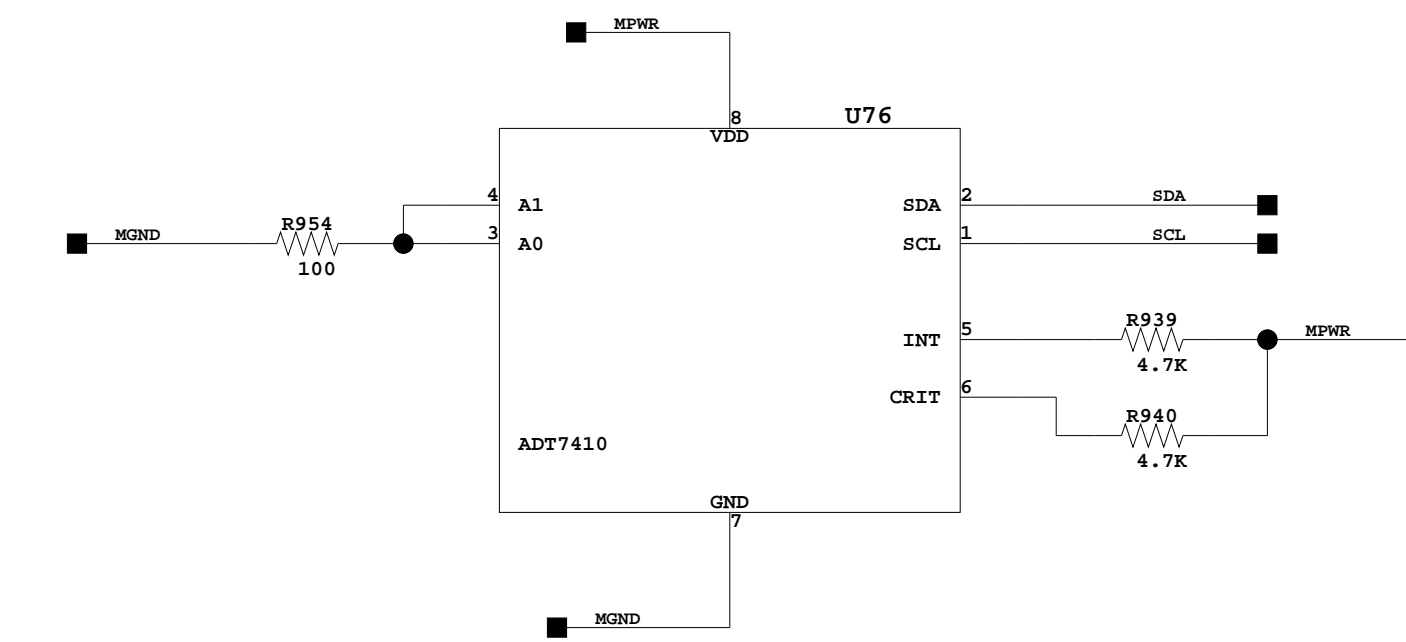

ADDR = 0x48

IO & EEPROM

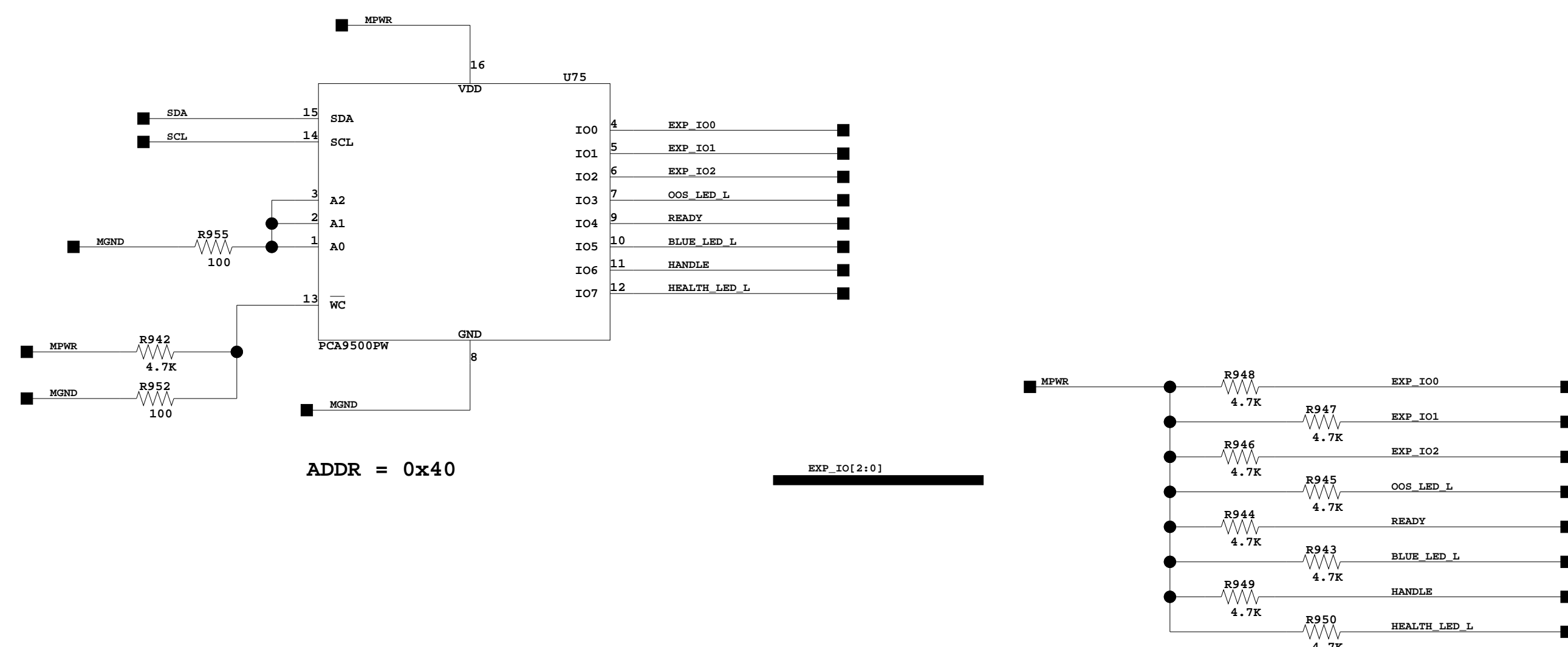

ADDR = 0x40

SERIAL ID

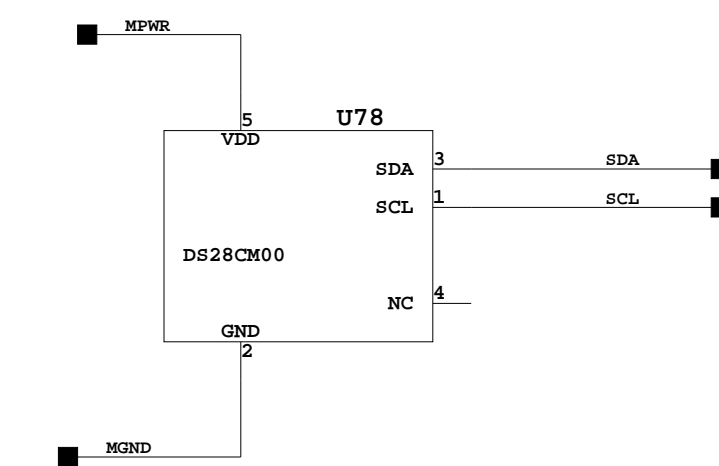

ADDR = 0x50

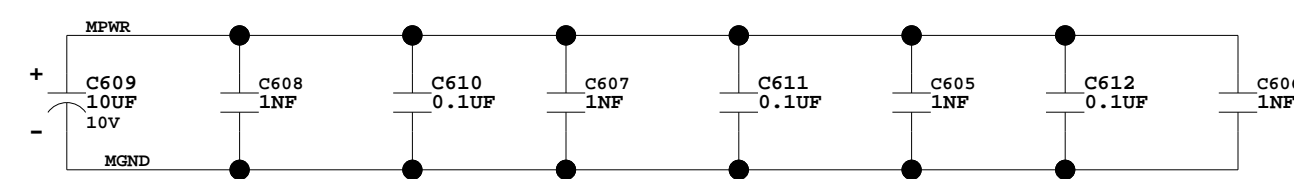

4-8-2011_14:54

SLAC NATIONAL ACCELERATOR LABORATORY U.S. DEPARTMENT OF ENERGY		IPMB CLIENT
STANFORD UNIVERSITY	STANFORD, CALIFORNIA	
PROPRIETARY DATA OF STANFORD UNIVERSITY AND/OR U.S. DEPARTMENT OF ENERGY. RECIPIENT SHALL NOT PUBLISH THE INFORMATION WITHIN UNLESS GRANTED SPECIFIC PERMISSION OF STANFORD UNIVERSITY.		
ENGR	Ryan Herbst	DATE
DFTG		2010
CDRR		APPROVALS

P31

ATCA_RTM_ZONE3_PLUG

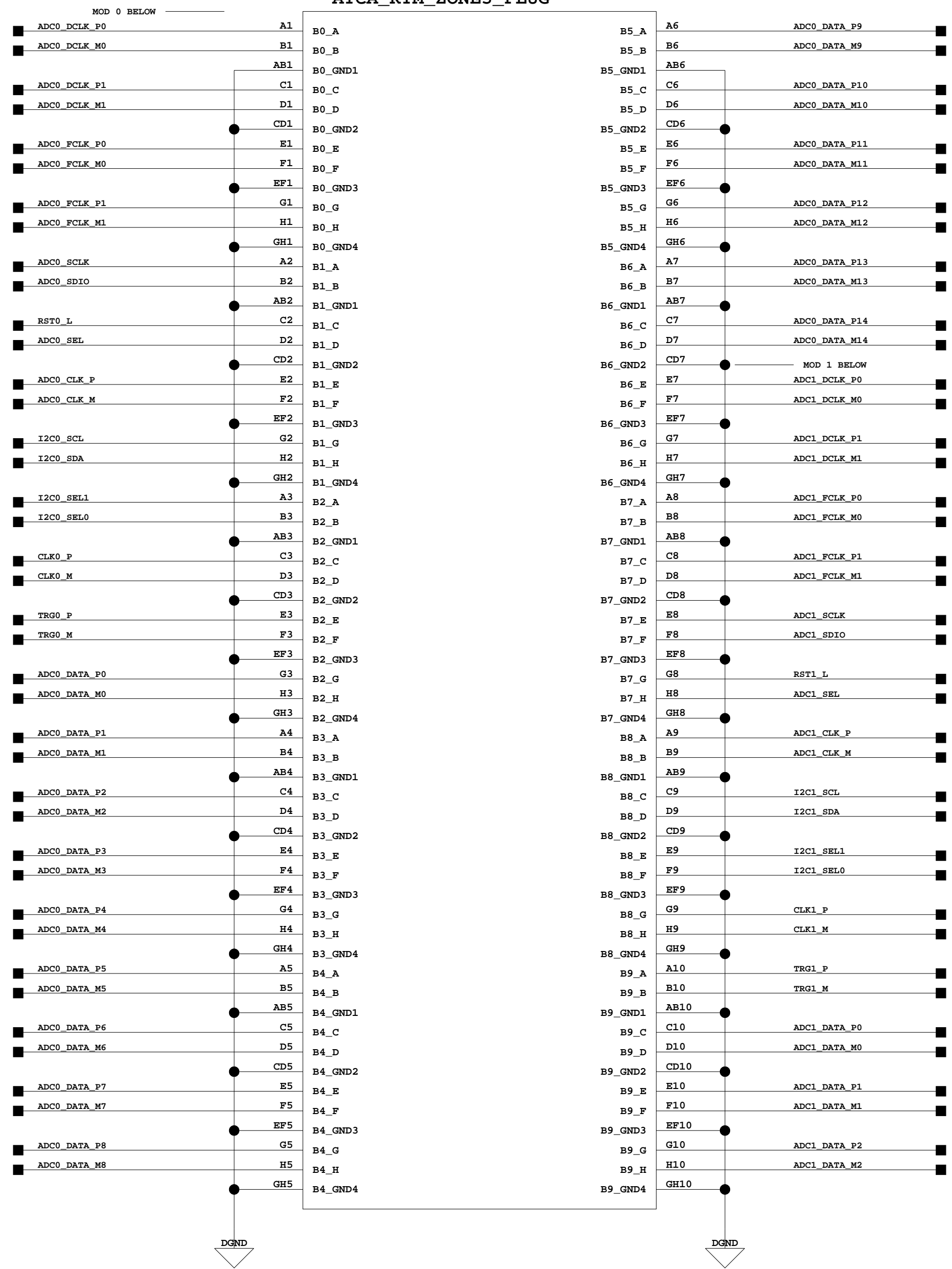

P32

ATCA_RTM_ZONE3_PLUG

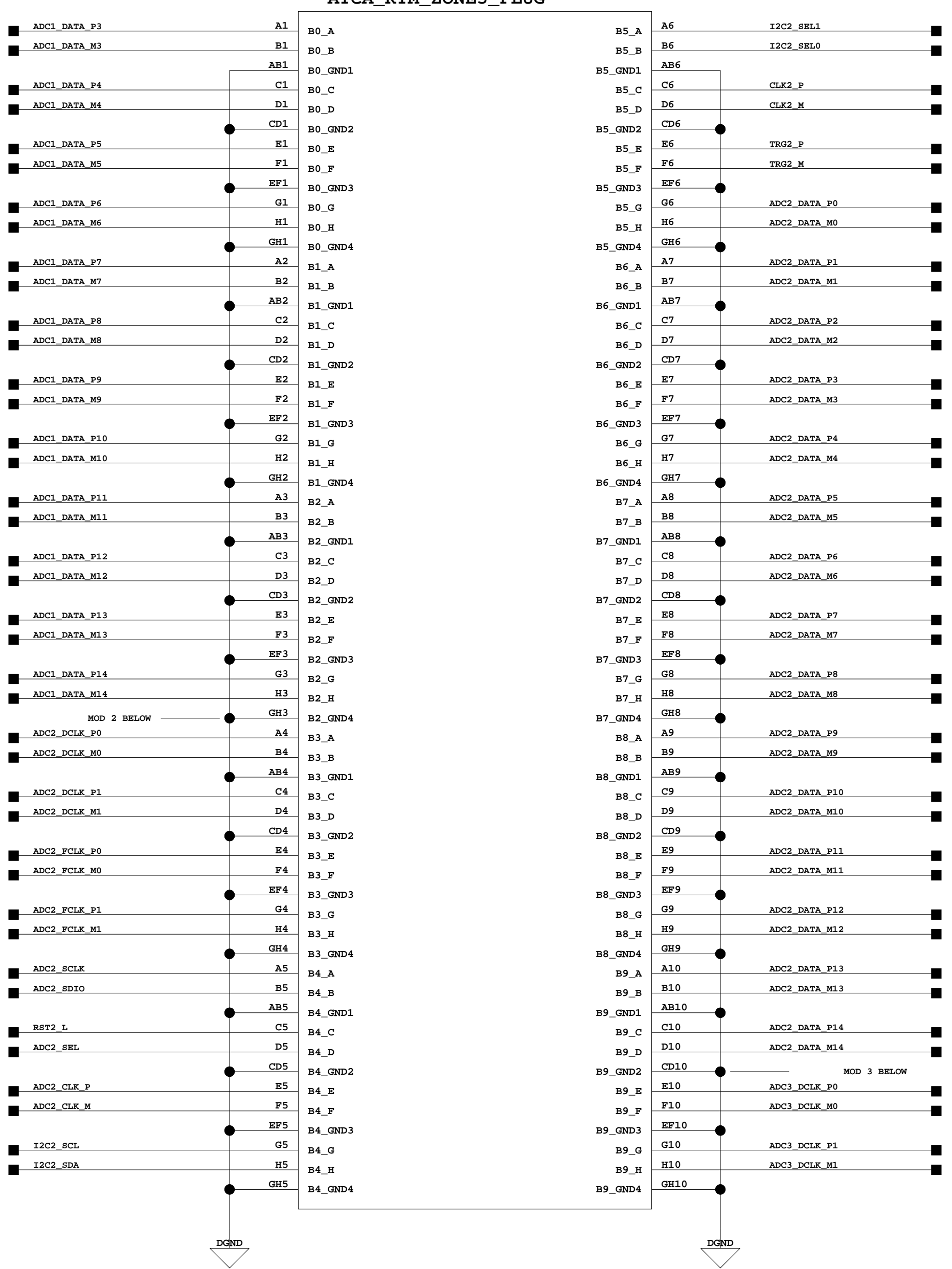

P33

ATCA_RTM_ZONE3_PLUG

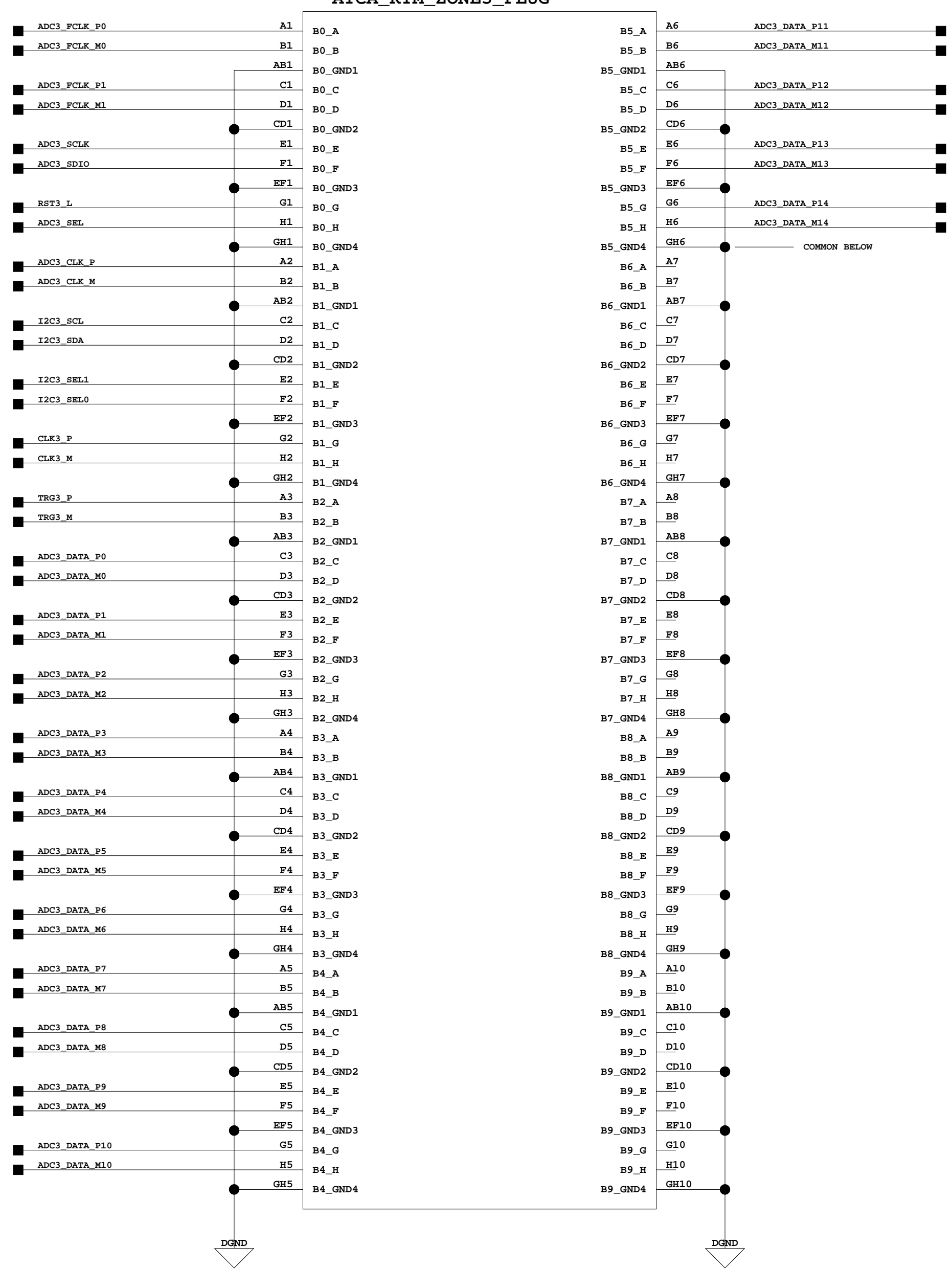

I2C[3:0] SCL	
I2C[3:0] SDA	
I2C[3:0] SEL[1:0]	
RST[3:0] L	
CLK[3:0] P	
CLK[3:0] M	
TRG[3:0] P	
TRG[3:0] M	
ADC[3:0] DCLK_P[1:0]	ADC[3:0] SCLK
ADC[3:0] DCLK_M[1:0]	ADC[3:0] SDIO
ADC[3:0] FCLK_P[1:0]	ADC[3:0] SEL
ADC[3:0] FCLK_M[1:0]	ADC[3:0] CLK_P
ADC[3:0] DATA_P[14:0]	ADC[3:0] CLK_M
ADC[3:0] DATA_M[14:0]	

4-11-2011_15:38

SLAC NATIONAL ACCELERATOR LABORATORY U.S. DEPARTMENT OF ENERGY		SHEET 23 OF 23
STANFORD UNIVERSITY PROPRIETARY DATA OF STANFORD UNIVERSITY AND/OR U.S. DEPARTMENT OF ENERGY. RECIPIENT SHALL NOT PUBLISH THE INFORMATION WITHIN UNLESS GRANTED SPECIFIC PERMISSION OF STANFORD UNIVERSITY.		HEAVY P TRACKER READOUT RTM ZONE 3 CONNECTOR
DATE 2010	APPROVALS Ryan Herbst	LOCATED AT SHEET 1 SD-249-901-02-C01